



はすば歯車 ねじ歯車

Helical Gears and Screw Gears

商品記号の読み方 Reference of Catalogue Number

ヘリカル・ギヤ (はすば歯車)

H 1 S 13 R - B
 H 1 SU 13 R - B
 H 1 D 13 L * B

歯車の種類 Kind of Gear	モジュール Module	材質 Material	歯数 Number of Teeth	ねじれ方向 Direction of Helix	穴仕上 Bores Processed	形状 Type
Helical gear (ヘリカル) Helical gears and Screw gears	m : 1.0 1.5 2.0 2.5 3.0	S : S45C Carbon Steel SU : ステンレス (SUS304) Stainless Steel D : ポリアセタール Poly Acetal (Machined) BP : ポリアセタール (青色) Poly Acetal (Blue)	z : 13 26	R : 右ねじれ Right Hand L : 左ねじれ Left Hand	【一】旋削加工 Gear without Key Way / without Thread hole. 【*】: ネジ穴付 旋削仕上げ Gear with two threaded holes / with two set screws.	B : 片ハブ付き with Hub on one side.

はすば歯車の使用上の注意

Usage precaution of Helical Gear

- 理想的な噛み合いをさせる為に、それぞれのねじ歯車の軸角 90 度はできるだけ正確に取りつけて下さい。
- ご使用の際、軸方向のスラストを生じますので軸方向スラストを十分耐えうる軸受にして下さい。
- はすば歯車のスラスト荷重について
はすば歯車は平歯車に比較して、噛み合いがなめらかなる長所がありますが、歯すじがねじれている為に軸方向のスラストを生じる欠点があります。したがって、軸方向スラストを十分支えるように軸受の設計をして下さい。

- To obtain ideal engagement of the shafts of Helical gears, provide right angle (90°) correctly.
- Provide the bearing that will completely support the thrust load when Helical gear is operated as the axial thrust direction.
- As for the thrust load of Helical gear.
Helical gear is able to obtain a smooth engagement compare to Spur gear, However Helical gear produces thrust load by helix angle on the tooth trace. Therefore the design of the shafts between drive gear (Pinion) and driven gear (Gear) should be in firm condition, and provide bearing that completely support pinion and gear against the axial thrust load.

はすば歯車の軸方向にかかるスラスト

Axial thrust load of helical gear and location of bearing

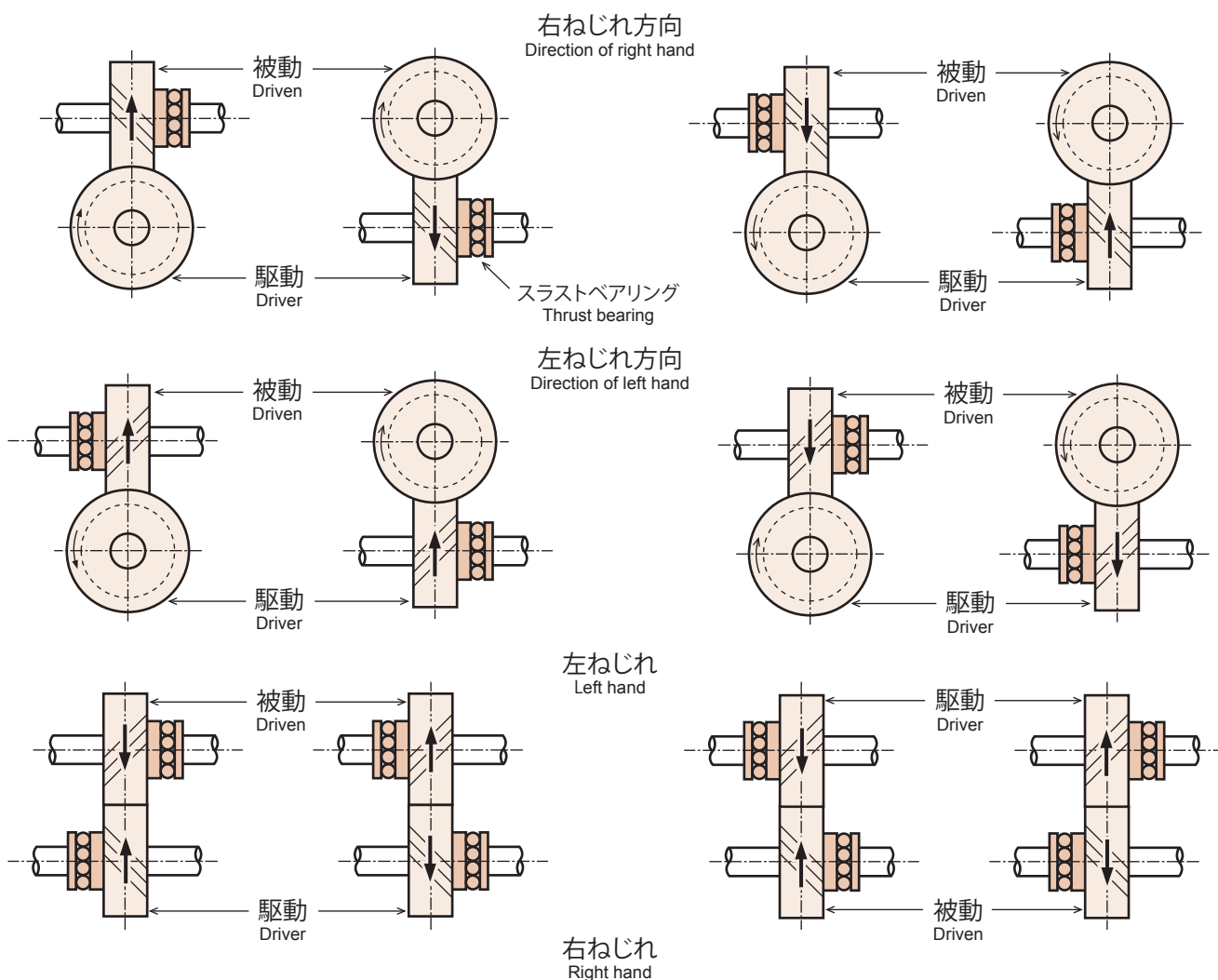

相手歯車を弊社以外の商品と組合わせて使用されますと、不具合が発生するおそれがあります。

KG STOCK GEARS 以外の仕様で設計される時は弊社までご相談ください。

KG-Helical gear is able to match with other gear makers however it is advisable to use KG-Gear for best result.

We are able to fabricate made to order according to your specifications. Please do not hesitate to contact us.

はすば歯車 / ねじ歯車 HELICAL GEARS

モジュール 1
MODULE 1

圧力角 20° (並歯) ねじれ角 45°
20° PRESSURE ANGLE FULL DEPTH TOOTH 45° Helix Angle

JIS B 1702-1 (ISO) 9~10 級
System of accuracy : JIS B 1702-1(ISO) class 9-10

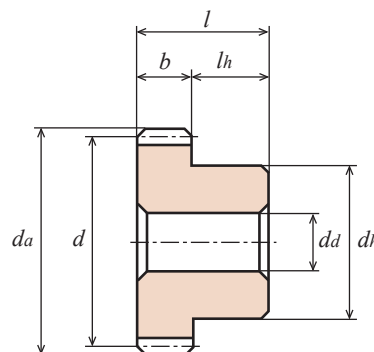

B1形
TYPE B1

ポリアセタール (青色)
Material : Poly Acetal (Blue)

単位 : mm
Dimensions : mm

商品記号 Catalogue Number	ねじれ方向 Direction of Helix	モジュール Module	歯数 Number of Teeth	基準円直径 Reference Diameter	歯先円直径 Tip Diameter	歯幅 Face Width	穴径 Bore Diameter	ハブ外径 Hub Diameter	ハブ長さ Hub Projection	全長 Overall Length	重量 Weight
		<i>m</i>	<i>z</i>	<i>d</i>	<i>da</i>	<i>b</i>	<i>da</i>	<i>dh</i>	<i>lh</i>	<i>l</i>	<i>W(g)</i>
● H1BP 10R - B	R	1	10	φ14.14	φ16.1	12	φ4	φ10	10	22	3.4
● H1BP 10L - B	L	1	10	φ14.14	φ16.1	12	φ4	φ10	10	22	3.4
● H1BP 13R - B	R	1	13	φ18.38	φ20.4	12	φ5	φ14	10	22	6.0
● H1BP 13L - B	L	1	13	φ18.38	φ20.4	12	φ5	φ14	10	22	6.0
● H1BP 15R - B	R	1	15	φ21.21	φ23.2	12	φ6	φ15	10	22	7.6
● H1BP 15L - B	L	1	15	φ21.21	φ23.2	12	φ6	φ15	10	22	7.6
● H1BP 20R - B	R	1	20	φ28.28	φ30.3	12	φ6	φ22	10	22	15.1
● H1BP 20L - B	L	1	20	φ28.28	φ30.3	12	φ6	φ22	10	22	15.1
● H1BP 26R - B	R	1	26	φ36.77	φ38.8	12	φ8	φ32	10	22	27.7
● H1BP 26L - B	L	1	26	φ36.77	φ38.8	12	φ8	φ32	10	22	27.7

●の商品は新商品です。
Products with ● marks are new item.

許容伝達動力表 歯面強さ (W) 食い違い軸

Allowable transfer capability table (W) Surface Durability for Non-parallel and Non-intersecting axes.

商品記号 Catalogue Numbers	回転速度 (min ⁻¹) revolution/min						
	10	100	200	400	800	1,200	1,500
H1BP 10R - B	0.06	0.51	1.03	2.05	3.29	3.70	4.62
H1BP 10L - B	0.06	0.51	1.03	2.05	3.29	3.70	4.62
H1BP 13R - B	0.13	1.23	2.47	4.11	6.57	8.63	9.24
H1BP 13L - B	0.13	1.23	2.47	4.11	6.57	8.63	9.24
H1BP 15R - B	0.21	1.95	3.70	6.16	9.86	12.32	13.86
H1BP 15L - B	0.21	1.95	3.70	6.16	9.86	12.32	13.86
H1BP 20R - B	0.50	4.62	8.42	14.38	22.18	27.11	29.27
H1BP 20L - B	0.50	4.62	8.42	14.38	22.18	27.11	29.27
H1BP 26R - B	1.10	9.86	17.46	28.75	42.72	50.52	53.91
H1BP 26L - B	1.10	9.86	17.46	28.75	42.72	50.52	53.91

The above numerical value are reference value.

- 目次 CONTENTS
- インフォメーション INFORMATION
- ギヤボックス GEAR BOXES
- ノーバックラッシュギヤ ANTIBACKLASH SPUR GEARS
- 平歯車 SPUR GEARS
- 内歯車 INTERNAL GEARS
- ラック RACKS
- シカトル・スクリューギヤ HELICAL GEARS AND SCREW GEARS
- ウォーム・ウォームホイール WORMS AND WORM WHEELS
- かみ歯車 BEVEL GEARS
- スプロケット SPURKETS
- 技術データ REFERENCE DATA

はすば歯車 / ねじ歯車 HELICAL GEARS

モジュール **1.5**
MODULE

圧力角 20° (並歯) ねじれ角 45°
20° PRESSURE ANGLE FULL DEPTH TOOTH 45° Helix Angle

JIS B 1702-1 (ISO) 9~10 級
System of accuracy : JIS B 1702-1(ISO) class 9-10

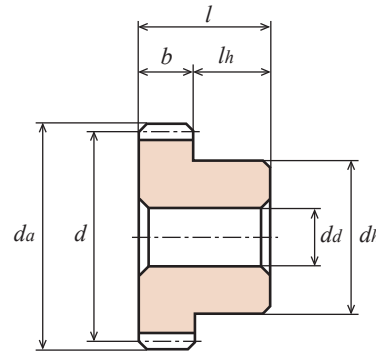
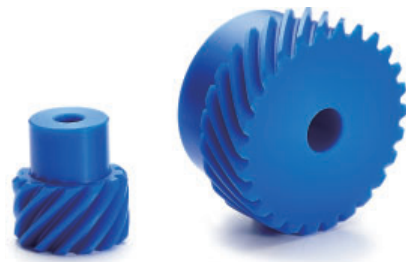

B1形
TYPE B1

ポリアセタール (青色)
Material : Poly Acetal (Blue)

単位 : mm
Dimensions : mm

商品記号 Catalogue Number	ねじれ方向 Direction of Helix	モジュール Module	歯数 Number of Teeth	基準円直径 Reference Diameter	歯先円直径 Tip Diameter	歯幅 Face Width	穴径 Bore Diameter	ハブ外径 Hub Diameter	ハブ長さ Hub Projection	全長 Overall Length	重量 Weight
		<i>m</i>	<i>z</i>	<i>d</i>	<i>da</i>	<i>b</i>	<i>da</i>	<i>dh</i>	<i>lh</i>	<i>l</i>	<i>W(g)</i>
● H1.5BP 10R - B	R	1.5	10	φ21.21	φ24.2	15	φ 6	φ16	10	25	9.3
● H1.5BP 10L - B	L	1.5	10	φ21.21	φ24.2	15	φ 6	φ16	10	25	9.3
● H1.5BP 13R - B	R	1.5	13	φ27.58	φ30.6	15	φ 8	φ23	10	25	16.6
● H1.5BP 13L - B	L	1.5	13	φ27.58	φ30.6	15	φ 8	φ23	10	25	16.6
● H1.5BP 15R - B	R	1.5	15	φ31.82	φ34.8	15	φ 8	φ25	10	25	22.0
● H1.5BP 15L - B	L	1.5	15	φ31.82	φ34.8	15	φ 8	φ25	10	25	22.0
● H1.5BP 20R - B	R	1.5	20	φ42.43	φ45.4	15	φ10	φ30	10	25	37.1
● H1.5BP 20L - B	L	1.5	20	φ42.43	φ45.4	15	φ10	φ30	10	25	37.1
● H1.5BP 26R - B	R	1.5	26	φ55.15	φ58.2	15	φ10	φ40	10	25	65.5
● H1.5BP 26L - B	L	1.5	26	φ55.15	φ58.2	15	φ10	φ40	10	25	65.5

●の商品は新商品です。
Products with ● marks are new item.

許容伝達動力表 歯面強さ (W) 食い違い軸

Allowable transfer capability table (W) Surface Durability for Non-parallel and Non-intersecting axes.

商品記号 Catalogue Numbers	回転速度 (min ⁻¹) revolution/min						
	10	100	200	400	800	1,200	1,500
H1.5BP 10R - B	0.21	1.95	3.70	6.16	9.86	12.32	13.86
H1.5BP 10L - B	0.21	1.95	3.70	6.16	9.86	12.32	13.86
H1.5BP 13R - B	0.46	4.11	7.80	13.14	20.54	24.65	27.73
H1.5BP 13L - B	0.46	4.11	7.80	13.14	20.54	24.65	27.73
H1.5BP 15R - B	0.72	6.47	11.71	19.72	29.58	35.74	38.51
H1.5BP 15L - B	0.72	6.47	11.71	19.72	29.58	35.74	38.51
H1.5BP 20R - B	1.69	14.89	26.08	42.31	60.79	71.47	77.02
H1.5BP 20L - B	1.69	14.89	26.08	42.31	60.79	71.47	77.02
H1.5BP 26R - B	3.71	31.42	53.81	83.39	115.01	130.62	138.63
H1.5BP 26L - B	3.71	31.42	53.81	83.39	115.01	130.62	138.63

The above numerical value are reference value.

はすば歯車 / ねじ歯車 HELICAL GEARS

モジュール 2
MODULE 2

圧力角 20° (並歯) ねじれ角 45°
20° PRESSURE ANGLE FULL DEPTH TOOTH 45° Helix Angle

JIS B 1702-1 (ISO) 9~10 級
System of accuracy : JIS B 1702-1(ISO) class 9-10

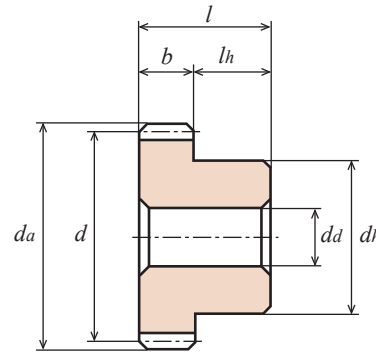

B1形
TYPE B1

ポリアセタール (青色)
Material : Poly Acetal (Blue)

単位 : mm
Dimensions : mm

商品記号 Catalogue Number	ねじれ方向 Direction of Helix	モジュール Module	歯数 Number of Teeth	基準円直径 Reference Diameter	歯先円直径 Tip Diameter	歯幅 Face Width	穴径 Bore Diameter	ハブ外径 Hub Diameter	ハブ長さ Hub Projection	全長 Overall Length	重量 Weight
		<i>m</i>	<i>z</i>	<i>d</i>	<i>da</i>	<i>b</i>	<i>da</i>	<i>dh</i>	<i>lh</i>	<i>l</i>	<i>W(g)</i>
● H2BP 10R - B	R	2	10	φ28.28	φ32.3	20	φ10	φ22	15	35	21.9
● H2BP 10L - B	L	2	10	φ28.28	φ32.3	20	φ10	φ22	15	35	21.9
● H2BP 13R - B	R	2	13	φ36.77	φ40.8	20	φ10	φ30	15	35	41.0
● H2BP 13L - B	L	2	13	φ36.77	φ40.8	20	φ10	φ30	15	35	41.0
● H2BP 15R - B	R	2	15	φ42.43	φ46.4	20	φ10	φ35	15	35	56.3
● H2BP 15L - B	L	2	15	φ42.43	φ46.4	20	φ10	φ35	15	35	56.3
● H2BP 20R - B	R	2	20	φ56.57	φ60.6	20	φ12	φ45	15	35	98.9
● H2BP 20L - B	L	2	20	φ56.57	φ60.6	20	φ12	φ45	15	35	98.9
● H2BP 26R - B	R	2	26	φ73.54	φ77.5	20	φ12	φ55	15	35	164.4
● H2BP 26L - B	L	2	26	φ73.54	φ77.5	20	φ12	φ55	15	35	164.4

●の商品は新商品です。
Products with ● marks are new item.

許容伝達動力表 歯面強さ (W) 食い違い軸

Allowable transfer capability table (W) Surface Durability for Non-parallel and Non-intersecting axes.

商品記号 Catalogue Numbers	回転速度 (min ⁻¹) revolution/min						
	10	100	200	400	800	1,200	1,500
H2BP 10R - B	0.50	4.62	8.42	14.38	22.18	27.11	29.27
H2BP 10L - B	0.50	4.62	8.42	14.38	22.18	27.11	29.27
H2BP 13R - B	1.10	9.86	17.46	28.75	42.72	50.52	53.91
H2BP 13L - B	1.10	9.86	17.46	28.75	42.72	50.52	53.91
H2BP 15R - B	1.69	14.89	26.08	42.31	60.79	71.47	77.02
H2BP 15L - B	1.69	14.89	26.08	42.31	60.79	71.47	77.02
H2BP 20R - B	4.00	33.79	57.51	88.73	121.59	139.25	147.87
H2BP 20L - B	4.00	33.79	57.51	88.73	121.59	139.25	147.87
H2BP 26R - B	8.74	70.55	116.25	171.70	225.92	251.39	264.94
H2BP 26L - B	8.74	70.55	116.25	171.70	225.92	251.39	264.94

The above numerical value are reference value.

- 目次 CONTENTS
- インフォメーション INFORMATION
- ギヤボックス GEAR BOXES
- ノーバックラッシュギヤ ANTIBACKLASH SPUR GEARS
- 平歯車 SPUR GEARS
- 内歯車 INTERNAL GEARS
- ラック RACKS
- シカトル・スクリューギヤ HELICAL GEARS AND SCREW GEARS
- ウォーム ウォームホイール WORMS AND WORM WHEELS
- かみ歯車 BEVEL GEARS
- スプロケット SPROCKETS
- 技術データ REFERENCE DATA

はすば歯車 / ねじ歯車 HELICAL GEARS

モジュール **2.5**
MODULE

圧力角 20° (並歯) ねじれ角 45°
20° PRESSURE ANGLE FULL DEPTH TOOTH 45° Helix Angle

JIS B 1702-1 (ISO) 9~10 級
System of accuracy : JIS B 1702-1(ISO) class 9-10

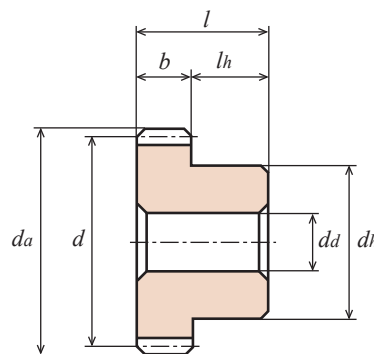

B1形
TYPE B1

ポリアセタール (青色)
Material : Poly Acetal (Blue)

単位 : mm
Dimensions : mm

商品記号 Catalogue Number	ねじれ方向 Direction of Helix	モジュール Module	歯数 Number of Teeth	基準円直径 Reference Diameter	歯先円直径 Tip Diameter	歯幅 Face Width	穴径 Bore Diameter	ハブ外径 Hub Diameter	ハブ長さ Hub Projection	全長 Overall Length	重量 Weight
		<i>m</i>	<i>z</i>	<i>d</i>	<i>da</i>	<i>b</i>	<i>da</i>	<i>dh</i>	<i>lh</i>	<i>l</i>	<i>W(g)</i>
● H2.5BP 10R - B	R	2.5	10	φ35.36	φ40.4	22	φ10	φ26	16	38	38.2
● H2.5BP 10L - B	L	2.5	10	φ35.36	φ40.4	22	φ10	φ26	16	38	38.2
● H2.5BP 13R - B	R	2.5	13	φ45.96	φ50.9	22	φ12	φ38	16	38	71.0
● H2.5BP 13L - B	L	2.5	13	φ45.96	φ50.9	22	φ12	φ38	16	38	71.0
● H2.5BP 15R - B	R	2.5	15	φ53.03	φ58.0	22	φ12	φ40	16	38	90.8
● H2.5BP 15L - B	L	2.5	15	φ53.03	φ58.0	22	φ12	φ40	16	38	90.8
● H2.5BP 20R - B	R	2.5	20	φ70.71	φ75.7	22	φ12	φ60	16	38	179.5
● H2.5BP 20L - B	L	2.5	20	φ70.71	φ75.7	22	φ12	φ60	16	38	179.5
● H2.5BP 26R - B	R	2.5	26	φ91.92	φ96.9	22	φ16	φ70	16	38	281.9
● H2.5BP 26L - B	L	2.5	26	φ91.92	φ96.9	22	φ16	φ70	16	38	281.9

●の商品は新商品です。
Products with ● marks are new item.

許容伝達動力表 歯面強さ (W) 食い違い軸

Allowable transfer capability table (W) Surface Durability for Non-parallel and Non-intersecting axes.

商品記号 Catalogue Numbers	回転速度 (min ⁻¹) revolution/min						
	10	100	200	400	800	1,200	1,500
H2.5BP 10R - B	0.98	8.73	15.81	25.88	38.61	45.60	49.29
H2.5BP 10L - B	0.98	8.73	15.81	25.88	38.61	45.60	49.29
H2.5BP 13R - B	2.15	18.69	32.66	52.17	73.94	86.26	92.42
H2.5BP 13L - B	2.15	18.69	32.66	52.17	73.94	86.26	92.42
H2.5BP 15R - B	3.30	28.14	48.27	75.17	104.33	119.53	127.85
H2.5BP 15L - B	3.30	28.14	48.27	75.17	104.33	119.53	127.85
H2.5BP 20R - B	7.77	63.26	104.74	155.68	206.20	230.44	241.84
H2.5BP 20L - B	7.77	63.26	104.74	155.68	206.20	230.44	241.84
H2.5BP 26R - B	16.96	130.83	208.67	296.98	376.26	414.05	429.76
H2.5BP 26L - B	16.96	130.83	208.67	296.98	376.26	414.05	429.76

The above numerical value are reference value.

はすば歯車 / ねじ歯車 HELICAL GEARS

モジュール 3
MODULE 3

圧力角 20° (並歯) ねじれ角 45°
20° PRESSURE ANGLE FULL DEPTH TOOTH 45° Helix Angle

JIS B 1702-1 (ISO) 9~10 級
System of accuracy : JIS B 1702-1(ISO) class 9-10

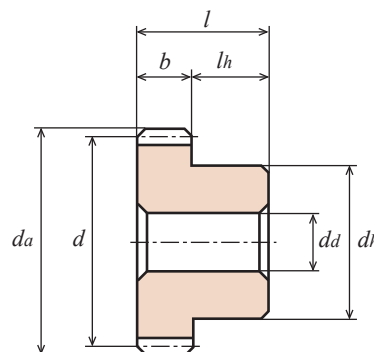

B1形
TYPE B1

ポリアセタール (青色)
Material : Poly Acetal (Blue)

単位 : mm
Dimensions : mm

商品記号 Catalogue Number	ねじれ方向 Direction of Helix	モジュール Module	歯数 Number of Teeth	基準円直径 Reference Diameter	歯先円直径 Tip Diameter	歯幅 Face Width	穴径 Bore Diameter	ハブ外径 Hub Diameter	ハブ長さ Hub Projection	全長 Overall Length	重量 Weight
		<i>m</i>	<i>z</i>	<i>d</i>	<i>da</i>	<i>b</i>	<i>da</i>	<i>dh</i>	<i>lh</i>	<i>l</i>	<i>W(g)</i>
● H3BP 10R - B	R	3	10	φ 42.43	φ 48.4	25	φ 12	φ 34	18	43	66.0
● H3BP 10L - B	L	3	10	φ 42.43	φ 48.4	25	φ 12	φ 34	18	43	66.0
● H3BP 13R - B	R	3	13	φ 55.15	φ 61.2	25	φ 15	φ 45	18	43	113.8
● H3BP 13L - B	L	3	13	φ 55.15	φ 61.2	25	φ 15	φ 45	18	43	113.8
● H3BP 15R - B	R	3	15	φ 63.64	φ 69.6	25	φ 15	φ 50	18	43	151.2
● H3BP 15L - B	L	3	15	φ 63.64	φ 69.6	25	φ 15	φ 50	18	43	151.2
● H3BP 20R - B	R	3	20	φ 84.85	φ 90.9	25	φ 15	φ 60	18	43	260.3
● H3BP 20L - B	L	3	20	φ 84.85	φ 90.9	25	φ 15	φ 60	18	43	260.3
● H3BP 26R - B	R	3	26	φ 110.31	φ 116.3	25	φ 18	φ 80	18	43	449.0
● H3BP 26L - B	L	3	26	φ 110.31	φ 116.3	25	φ 18	φ 80	18	43	449.0

●の商品は新商品です。
Products with ● marks are new item.

許容伝達動力表 歯面強さ (W) 食い違い軸

Allowable transfer capability table (W) Surface Durability for Non-parallel and Non-intersecting axes.

商品記号 Catalogue Numbers	回転速度 (min ⁻¹) revolution/min						
	10	100	200	400	800	1,200	1,500
H3BP 10R - B	1.69	14.89	26.08	42.31	60.79	71.47	77.02
H3BP 10L - B	1.69	14.89	26.08	42.31	60.79	71.47	77.02
H3BP 13R - B	3.71	31.42	53.81	83.39	115.01	130.62	138.63
H3BP 13L - B	3.71	31.42	53.81	83.39	115.01	130.62	138.63
H3BP 15R - B	5.68	47.03	79.07	119.53	161.02	182.38	192.55
H3BP 15L - B	5.68	47.03	79.07	119.53	161.02	182.38	192.55
H3BP 20R - B	13.37	104.95	169.44	244.40	313.82	346.27	361.98
H3BP 20L - B	13.37	104.95	169.44	244.40	313.82	346.27	361.98
H3BP 26R - B	29.12	215.24	333.54	460.05	567.67	616.14	637.71
H3BP 26L - B	29.12	215.24	333.54	460.05	567.67	616.14	637.71

The above numerical value are reference value.

目次
CONTENTS

インフォメーション
INFORMATION

ギヤボックス
GEAR BOXES

ノーバックラッシュギヤ
ANTI-BACKLASH SPUR GEARS

平歯車
SPUR GEARS

内歯車
INTERNAL GEARS

ラック
RACKS

シカトル・スクリューギヤ
HELICAL GEARS AND SCREW GEARS

ウォーム・ウォームホイール
WORMS AND WORM WHEELS

かさね歯車
BEVEL GEARS

スプロケット
SPROCKETS

技術資料
REFERENCE DATA

はすば歯車 / ねじ歯車

HELICAL GEARS

モジュール **1/1.5** 圧力角 20° (並歯) ねじれ角 45°
 20° PRESSURE ANGLE FULL DEPTH TOOTH 45° Helix Angle

JIS B 1702-1 (ISO) 9~10 級
 System of accuracy : JIS B 1702-1(ISO) class 9-10

New **ねじを2箇所 (120°配) にしました。**
 New item with two threaded holes (120°)

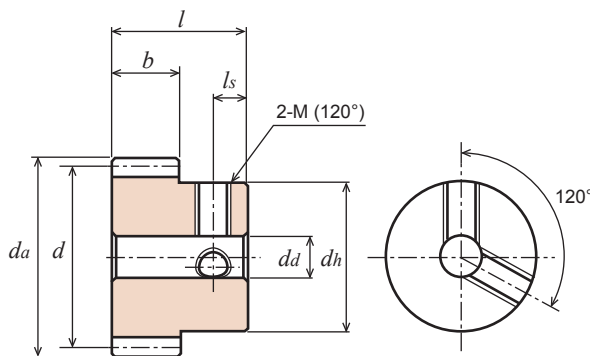

B1形
TYPE B1

ポリアセタール (白色)
 Material : Poly Acetal (White)

単位 : mm
 Dimensions : mm

商品記号 Catalogue Number	ねじれ方向 Direction of Helix	モジュール Module	歯数 Number of Teeth	基準円直径 Reference Diameter	歯先円直径 Tip Diameter	歯幅 Face Width	穴径 Bore Diameter	ハブ外径 Hub Diameter	ハブ長さ Hub Projection	全長 Overall Length	ねじ Set Screw		重量 Weight
											2-M(120°)	ls	
H1D 13R - B	R	1	13	φ18.38	φ20.4	12	φ 8	φ15	10	22	-	-	5.4
H1D 13L - B	L	1	13	φ18.38	φ20.4	12	φ 8	φ15	10	22	-	-	5.4
H1D 26R - B	R	1	26	φ36.77	φ38.8	12	φ10	φ32	10	22	-	-	26.9
H1D 26L - B	L	1	26	φ36.77	φ38.8	12	φ10	φ32	10	22	-	-	26.9
H1D 13R * B	R	1	13	φ18.38	φ20.4	12	φ 8	φ15	10	22	2-M3	5	5.3
H1D 13L * B	L	1	13	φ18.38	φ20.4	12	φ 8	φ15	10	22	2-M3	5	5.3
H1D 26R * B	R	1	26	φ36.77	φ38.8	12	φ10	φ32	10	22	2-M4	5	26.6
H1D 26L * B	L	1	26	φ36.77	φ38.8	12	φ10	φ32	10	22	2-M4	5	26.6
H1.5D 13R - B	R	1.5	13	φ27.58	φ30.6	15	φ10	φ23	10	25	-	-	15.7
H1.5D 13L - B	L	1.5	13	φ27.58	φ30.6	15	φ10	φ23	10	25	-	-	15.7
H1.5D 26R - B	R	1.5	26	φ55.15	φ58.2	15	φ12	φ40	10	25	-	-	64.2
H1.5D 26L - B	L	1.5	26	φ55.15	φ58.2	15	φ12	φ40	10	25	-	-	64.2
H1.5D 13R * B	R	1.5	13	φ27.58	φ30.6	15	φ10	φ23	10	25	2-M4	5	15.5
H1.5D 13L * B	L	1.5	13	φ27.58	φ30.6	15	φ10	φ23	10	25	2-M4	5	15.5
H1.5D 26R * B	R	1.5	26	φ55.15	φ58.2	15	φ12	φ40	10	25	2-M5	5	63.6
H1.5D 26L * B	L	1.5	26	φ55.15	φ58.2	15	φ12	φ40	10	25	2-M5	5	63.6

[*] (アスタ)にはセットスクリーが2個付いております。[*]: Gear with two threaded holes / with two set screws.

はすば歯車 (軸平行) 許容伝達動力表 曲げ強さ (W)

Allowable transfer capability table
 The table below shows the Bending strength applicable for parallel axis only.

商品記号 Catalogue Numbers	回転速度 (min ⁻¹) revolution/min						
	10	100	200	400	800	1,200	1,500
H1D 13R	2.98	29.75	59.46	118.79	237.06	354.80	442.76
H1D 26R	5.95	59.46	118.79	237.06	472.02	704.88	875.19
H1.5D 13R	4.71	47.10	94.12	187.93	374.61	560.04	698.30
H1.5D 26R	9.43	94.12	187.93	374.61	744.23	1,099.52	1,356.90

The above numerical values are equivalent to JGMA formulas as reference only.

動力の換算式は P34 をご参照ください。

Please refer to the conversion formulas of power on page P34.

はすば歯車 / ねじ歯車

HELICAL GEARS

モジュール **1/1.5** 圧力角 20° (並歯) ねじれ角 45°
 MODULE 20° PRESSURE ANGLE FULL DEPTH TOOTH 45° Helix Angle

JIS B 1702-1 (ISO) 9 級
 System of accuracy : JIS B 1702-1(ISO) class 9

御注文には必ず “フルネームで商品記号” を明記してください。
 Please refer to the catalogue reference while ordering.

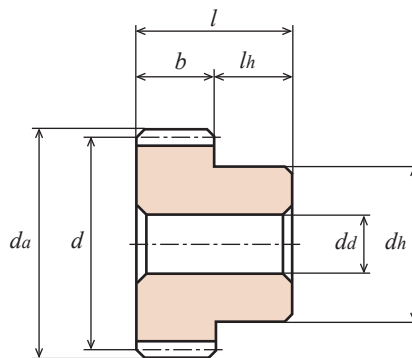

B1形
 TYPE B1

SUS304 ステンレス鋼棒 (JIS G 4303)

Material : Stainless SUS304 (JIS G 4303)

単位 : mm
 Dimensions : mm

商品記号 Catalogue Number	ねじれ方向 Direction of Helix	モジュール Module <i>m</i>	歯数 Number of Teeth <i>z</i>	基準円直径 Reference Diameter <i>d</i>	歯先円直径 Tip Diameter <i>da</i>	歯幅 Face Width <i>b</i>	穴径 Bore Diameter <i>da(H8)</i>	ハブ外径 Hub Diameter <i>dh</i>	ハブ長さ Hub Projection <i>lh</i>	全長 Overall Length <i>l</i>	ねじ Set Screw		重量 Weight <i>W(g)</i>
											2-M(120°)	ls	
H1SU 13R - B	R	1	13	φ18.38	φ20.4	12	φ 8	φ15	10	22	-	-	30.5
H1SU 13L - B	L	1	13	φ18.38	φ20.4	12	φ 8	φ15	10	22	-	-	30.5
H1SU 26R - B	R	1	26	φ36.77	φ38.8	12	φ10	φ32	10	22	-	-	151.1
H1SU 26L - B	L	1	26	φ36.77	φ38.8	12	φ10	φ32	10	22	-	-	151.1
H1SU 13R * B	R	1	13	φ18.38	φ20.4	12	φ 8	φ15	10	22	2-M3	5	30.2
H1SU 13L * B	L	1	13	φ18.38	φ20.4	12	φ 8	φ15	10	22	2-M3	5	30.2
H1SU 26R * B	R	1	26	φ36.77	φ38.8	12	φ10	φ32	10	22	2-M4	5	149.3
H1SU 26L * B	L	1	26	φ36.77	φ38.8	12	φ10	φ32	10	22	2-M4	5	149.3
H1.5SU 13R - B	R	1.5	13	φ27.58	φ30.6	15	φ10	φ23	10	25	-	-	88.4
H1.5SU 13L - B	L	1.5	13	φ27.58	φ30.6	15	φ10	φ23	10	25	-	-	88.4
H1.5SU 26R - B	R	1.5	26	φ55.15	φ58.2	15	φ12	φ40	10	25	-	-	361.4
H1.5SU 26L - B	L	1.5	26	φ55.15	φ58.2	15	φ12	φ40	10	25	-	-	361.4
H1.5SU 13R * B	R	1.5	13	φ27.58	φ30.6	15	φ10	φ23	10	25	2-M4	5	87.4
H1.5SU 13L * B	L	1.5	13	φ27.58	φ30.6	15	φ10	φ23	10	25	2-M4	5	87.4
H1.5SU 26R * B	R	1.5	26	φ55.15	φ58.2	15	φ12	φ40	10	25	2-M5	5	357.9
H1.5SU 26L * B	L	1.5	26	φ55.15	φ58.2	15	φ12	φ40	10	25	2-M5	5	357.9

SUS304 の商品にはセットスクリューは付いておりません。

[*] : Gear with two threaded holes / without set screw.

はすば歯車 (軸平行) 許容伝達動力表 曲げ強さ (W)

Allowable transfer capability table
 The table below shows the Bending strength applicable for parallel axis only.

商品記号 Catalogue Numbers	回転速度 (min ⁻¹) revolution/min						
	10	100	200	400	800	1,200	1,500
H1SU 13R	4.07	40.68	81.36	162.73	325.46	477.08	572.13
H1SU 26R	9.50	95.02	190.03	380.06	703.15	952.90	1,110.70
H1.5SU 13R	11.44	114.42	228.83	457.67	894.52	1,237.04	1,460.79
H1.5SU 26R	26.72	267.23	534.46	1,044.61	1,786.69	2,423.37	2,933.19

The above numerical values are equivalent to JGMA formulas as reference only.

動力の換算式は P34 をご参照ください。

Please refer to the conversion formulas of power on page P34.

目次 CONTENTS

インフォメーション INFORMATION

ギヤボックス GEAR BOXES

ノーバックラッシュギヤ ANTI-BACKLASH SPUR GEARS

平歯車 SPUR GEARS

内歯車 INTERNAL GEARS

ラック RACKS

シカトル・スプロケットギヤ HELICAL GEARS AND GEAR WHEELS

ウォーム・ウォームホイール WORMS AND WORM WHEELS

かみ歯車 BEVEL GEARS

スプロケット SPURGEETS

技術資料 REFERENCE DATA

はすば歯車 / ねじ歯車

HELICAL GEARS

モジュール **1/1.5**
MODULE

圧力角 20° (並歯) ねじれ角 45°
20° PRESSURE ANGLE FULL DEPTH TOOTH 45° Helix Angle

JIS B 1702-1 (ISO) 9 級
System of accuracy : JIS B 1702-1(ISO) class 9

New **ねじを2箇所 (120°配) にしました。**
New item with two threaded holes (120°)

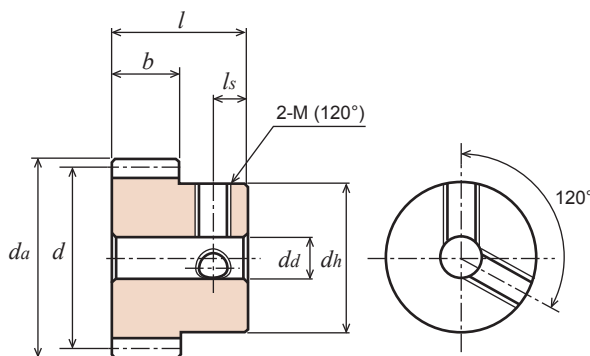

B1形
TYPE B1

S45C 機械構造用炭素鋼

Material : Carbon Steel (ISO C45)

単位 : mm
Dimensions : mm

商品記号 Catalogue Number	ねじれ方向 Direction of Helix	モジュール Module	歯数 Number of Teeth	基準円直径 Reference Diameter	歯先円直径 Tip Diameter	歯幅 Face Width	穴径 Bore Diameter	ハブ外径 Hub Diameter	ハブ長さ Hub Projection	全長 Overall Length	ねじ Set Screw		重量 Weight
											2-M(120°)	ls	
H1S 13R - B	R	1	13	φ18.38	φ20.4	12	φ 8	φ15	10	22	-	-	0.03
H1S 13L - B	L	1	13	φ18.38	φ20.4	12	φ 8	φ15	10	22	-	-	0.03
H1S 26R - B	R	1	26	φ36.77	φ38.8	12	φ10	φ32	10	22	-	-	0.15
H1S 26L - B	L	1	26	φ36.77	φ38.8	12	φ10	φ32	10	22	-	-	0.15
H1S 13R * B	R	1	13	φ18.38	φ20.4	12	φ 8	φ15	10	22	2-M3	5	0.03
H1S 13L * B	L	1	13	φ18.38	φ20.4	12	φ 8	φ15	10	22	2-M3	5	0.03
H1S 26R * B	R	1	26	φ36.77	φ38.8	12	φ10	φ32	10	22	2-M4	5	0.15
H1S 26L * B	L	1	26	φ36.77	φ38.8	12	φ10	φ32	10	22	2-M4	5	0.15
H1.5S 13R - B	R	1.5	13	φ27.58	φ30.6	15	φ10	φ23	10	25	-	-	0.09
H1.5S 13L - B	L	1.5	13	φ27.58	φ30.6	15	φ10	φ23	10	25	-	-	0.09
H1.5S 26R - B	R	1.5	26	φ55.15	φ58.2	15	φ12	φ40	10	25	-	-	0.36
H1.5S 26L - B	L	1.5	26	φ55.15	φ58.2	15	φ12	φ40	10	25	-	-	0.36
H1.5S 13R * B	R	1.5	13	φ27.58	φ30.6	15	φ10	φ23	10	25	2-M4	5	0.09
H1.5S 13L * B	L	1.5	13	φ27.58	φ30.6	15	φ10	φ23	10	25	2-M4	5	0.09
H1.5S 26R * B	R	1.5	26	φ55.15	φ58.2	15	φ12	φ40	10	25	2-M5	5	0.36
H1.5S 26L * B	L	1.5	26	φ55.15	φ58.2	15	φ12	φ40	10	25	2-M5	5	0.36

歯部高周波焼き入れ HRC 47 ~ 53

Gear tooth surface completed with induction hardening, Hardness HRC 47 to 53.

[*] (アスタ) にはセットスクリューが2個付いております。[*] : Gear with two threaded holes / with two set screws.

はすば歯車 (軸平行) 許容伝達動力表 曲げ強さ (kW)

Allowable transfer capability table

The table below shows the Bending strength applicable for parallel axis only.

商品記号 Catalogue Numbers	回転速度 (min ⁻¹) revolution/min						
	10	100	200	400	800	1,200	1,500
H1S 13R	0.009	0.09	0.19	0.38	0.77	1.13	1.36
H1S 26R	0.022	0.22	0.45	0.90	1.67	2.26	2.64
H1.5S 13R	0.027	0.27	0.54	1.08	2.12	2.94	3.47
H1.5S 26R	0.063	0.63	1.27	2.48	4.25	5.76	6.98

歯面強さ (kW)

Allowable transfer capability table (kW) Surface Durability

商品記号 Catalogue Numbers	回転速度 (min ⁻¹) revolution/min						
	10	100	200	400	800	1,200	1,500
H1S 13R	0.003	0.03	0.07	0.14	0.28	0.42	0.51
H1S 26R	0.015	0.15	0.31	0.64	1.20	1.65	1.95
H1.5S 13R	0.010	0.10	0.20	0.41	0.81	1.14	1.36
H1.5S 26R	0.045	0.45	0.91	1.81	3.16	4.37	5.35

The above numerical values are equivalent to JGMA formulas as reference only.

動力の換算式は P34 をご参照ください。Please refer to the conversion fomulas of power on page P34.

御注文には必ず“フルネームで商品記号”を明記してください。
Please refer to the catalogue reference while ordering.

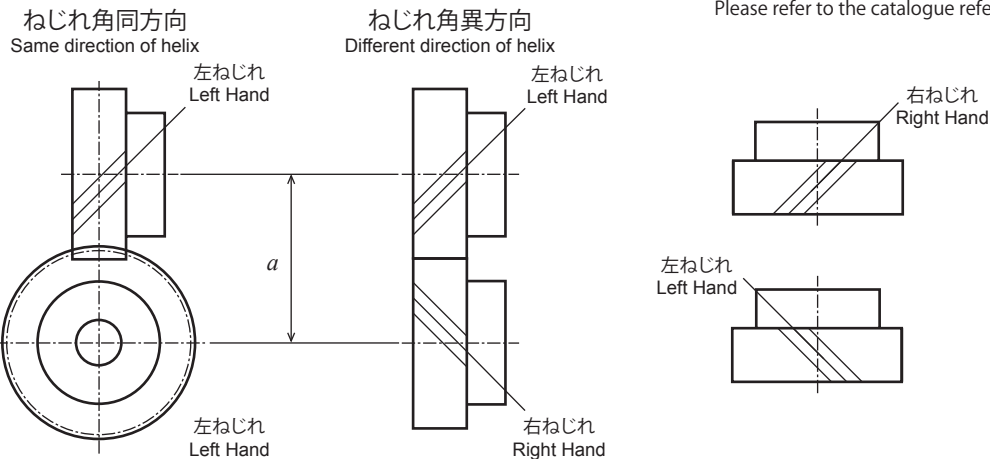

S45C 機械構造用炭素鋼

Material : Carbon Steel (ISO C45)

単位 : mm
Dimensions : mm

商品記号 Catalogue Number	ねじれ方向 Direction of Helix	モジュール Module <i>m</i>	歯数 Number of Teeth <i>z</i>	基準円直径 Reference Diameter <i>d</i>	歯先円直径 Tip Diameter <i>d_a</i>	歯幅 Face Width <i>b</i>	穴径 Bore Diameter <i>d_a(H8)</i>	ハブ外径 Hub Diameter <i>d_h</i>	ハブ長さ Hub Projection <i>l_h</i>	全長 Overall Length <i>l</i>	重量 Weight <i>W(kg)</i>
H2S 13R - B	R	2	13	φ 36.77	φ 40.8	20	φ12	φ30	13	33	0.21
H2S 13L - B	L	2	13	φ 36.77	φ 40.8	20	φ12	φ30	13	33	0.21
H2S 26R - B	R	2	26	φ 73.54	φ 77.5	20	φ16	φ55	13	33	0.86
H2S 26L - B	L	2	26	φ 73.54	φ 77.5	20	φ16	φ55	13	33	0.86
H2.5S 13R - B	R	2.5	13	φ 45.96	φ 50.9	22	φ14	φ38	14	36	0.37
H2.5S 13L - B	L	2.5	13	φ 45.96	φ 50.9	22	φ14	φ38	14	36	0.37
H2.5S 26R - B	R	2.5	26	φ 91.92	φ 96.9	22	φ18	φ63	14	36	1.41
H2.5S 26L - B	L	2.5	26	φ 91.92	φ 96.9	22	φ18	φ63	14	36	1.41
H3S 13R - B	R	3	13	φ 55.15	φ 61.2	25	φ16	φ44	15	40	0.58
H3S 13L - B	L	3	13	φ 55.15	φ 61.2	25	φ16	φ44	15	40	0.58
H3S 26R - B	R	3	26	φ110.31	φ116.3	25	φ22	φ70	15	40	2.21
H3S 26L - B	L	3	26	φ110.31	φ116.3	25	φ22	φ70	15	40	2.21

歯部高周波焼き入れ HRC 47 ~ 53
Gear tooth surface completed with induction hardening, Hardness HRC 47 to 53.

はすば歯車 (軸平行) 許容伝達動力表 曲げ強さ (kW)

Allowable transfer capability table
The table below shows the Bending strength applicable for parallel axis only.

商品記号 Catalogue Numbers	回転速度 (min ⁻¹) revolution/min						
	10	100	200	400	800	1,200	1,500
H2S 13R - B	0.06	0.64	1.29	2.58	4.77	6.47	7.54
H2S 26R - B	0.15	1.50	2.99	5.53	9.17	12.99	15.73
H2.5S 13R - B	0.11	1.10	2.21	4.41	7.75	10.31	12.43
H2.5S 26R - B	0.26	2.57	5.15	9.04	15.34	21.67	26.20
H3S 13R - B	0.18	1.82	3.63	7.10	12.14	16.47	19.93
H3S 26R - B	0.42	4.22	8.24	14.10	24.43	34.56	42.17
H4S 13R - B	0.38	3.78	7.56	13.99	23.20	32.86	39.78

歯面強さ (kW)

Allowable transfer capability table (kW) Surface Durability

商品記号 Catalogue Numbers	回転速度 (min ⁻¹) revolution/min						
	10	100	200	400	800	1,200	1,500
H2S 13R - B	0.02	0.24	0.49	0.99	1.87	2.57	3.03
H2S 26R - B	0.11	1.07	2.16	4.06	6.91	9.98	12.23
H2.5S 13R - B	0.04	0.52	0.85	1.71	3.06	4.14	5.04
H2.5S 26R - B	0.19	1.87	3.79	6.78	11.83	17.08	20.92
H3S 13R - B	0.07	0.71	1.42	2.82	4.92	6.79	8.31
H3S 26R - B	0.31	3.11	6.15	10.75	19.22	27.82	34.40
H4S 13R - B	0.15	1.52	3.06	5.75	9.77	14.12	17.31

The above references are JGMA standard.

動力の換算式は P34 をご参照ください。Please refer to the conversion formulas of power on page P34.

目次 CONTENTS
インフォメーション INFORMATION
ギヤボックス GEAR BOXES
ノーバックラッシュギヤ ANTIBACKLASH SPUR GEARS
平歯車 SPUR GEARS
内歯車 INTERNAL GEARS
ラック RACKS
リカル・スクリューギヤ HELICAL GEARS AND SCREW GEARS
ウォーム・ウォームホイール WORMS AND WORM WHEELS
かみ歯車 BEVEL GEARS
スプロケット SPROCKETS
技術データ REFERENCE DATA

Memo

目次
CONTENTS

インフォメーション
INFORMATION

ギヤボックス
GEAR BOXES

ノーバックラッシュギヤ
ANTI-BACKLASH SPUR GEARS

平歯車
SPUR GEARS

内歯車
INTERNAL GEARS

ラック
RACKS

ヘリカル・スクリューギヤ
HELICAL GEARS AND SCREW GEARS

ウォーム
ウォームホイール
WORMS AND WORM WHEELS

かさ歯車
BEVEL GEARS

スプロケット
SPROCKETS

技術資料
REFERENCE DATA