

KG STOCK GEARS

CATALOGUE No.
KG2003

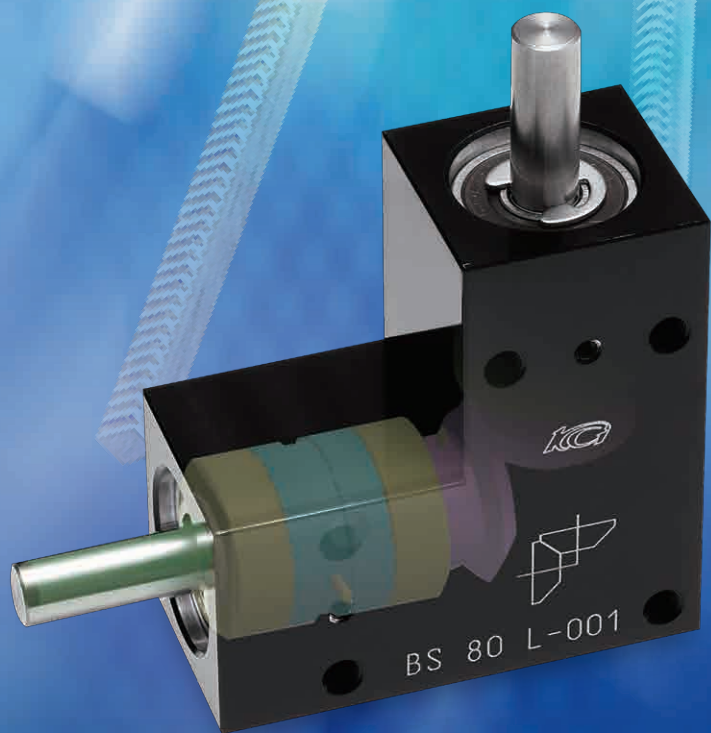

RKG シリーズ 精密歯研ラック

RKG Precision Ground Racks

歯研ラックのラインアップが増えました！

P285 をご参照下さい。



歯部に高周波焼入れを施し、全面研磨仕上げの高精度歯研ラックギヤをカタログ商品に追加しました。
New Precision Ground Racks with induction hardening and all surfaces are ground.

RKG 精密歯研ラックの相手歯車は、以下の歯研平歯車からお選びください。

Please select Mating Gears of RKG Ground Racks from the following ground spur gears.

歯研平歯車 (SG, SGE)
Ground spur gears



歯研ノーバックラッシギヤ
Antibacklash ground spur gears



歯研コントロールバックラッシギヤ
Control backlash ground spur gears



	新シリーズ NEW PRODUCTS	従来シリーズ CONVENTIONAL PRODUCTS
モジュール MODULE	m1.0 m1.5 m2.0 m2.5 m3.0	m0.5 m0.8 m1.0 m1.5
全長 OVERALL LENGTH	500mm 1000mm	200mm (m0.5 m0.8) 300mm (m1.0 m1.5)
熱処理 Heat Treatment	歯部高周波焼入れ Induction Hardening	素材調質 Thermal Refining to the raw material

選択肢が広がる平歯車シリーズです。

KG spur gears are available in the wide range of selection.

SGE シリーズ SGE Ground Spur Gears



S-H シリーズ S-H Spur Gears



BF シリーズ BF Spur Gears



	精度 System of accuracy	モジュール Module	特徴 Features
SGE シリーズ SGE: Ground spur gears	JIS B 1702-1 N7	m0.5 ~ m3.0	歯面研削のみのエコノミータイプの歯研平歯車です Competitive-price ground spur gears
S-H シリーズ S-H: Spur gears	JIS B 1702-1 N9		歯部高周波焼入れを施し、お客様の熱処理工程の手間を省いた商品です。 Spur gears with induction hardening
BF シリーズ BF: Spur gears	JIS B 1702-1 N8		穴径を小さく、ハブを大きくして追加工の範囲を広げた追加工に最適な平歯車です。 Suitable for additional machining with minimum bore diameter

KG ギヤ・インフォメーション

KG Gear - Information

特注品（オーダーメイド）について
Customize making gears.

お客様のニーズにお応えした**特注歯車**を1個からご提供いたします。



弊社では、精密小型規格歯車の生産ノウハウを活かし、規格品以外の特注品（オーダーメイド歯車）も請け賜ります。

We make customized gears with our past experience and know-how of precise and small standard gears from 1pc.

小モジュール・小型歯車 平歯車・かさ歯車にも対応。検査体制も整えています。
We make precise and small Spur and Bevel gears with full inspection systems.



モジュール 0.3 の平歯車・かさ歯車にも対応しております。
We are able to make module 0.3 Spur and Bevel gears.



小モジュール・小型歯車の検査にはニコン社製 高精度非接触センサー 3D システム「HN-C3030P」を採用しています。

We inspect precise and small gears with non-contact sensor 3D metrology system "HN-C3030P" from Nikon.

特注歯車 諸元確認リスト

When enquiries, please refer to and check the following table.

Dimenstions with ○ mark in your specification sheet or drawing help with our quick consideration.

	サイズ Size	材質 Material	歯数 No. of teeth	形状 Shape	外径 Outsied diameter	ねじれ角と方向 Herical angle and direction of thread	条数 Number of thread	相手歯車歯数 No. of teeth of mating gears	組立距離 Locating distance	熱処理 Heat treatment	表面処理 Surface treatment
平歯車 Spur Gears	○	○	○	○						○	○
ラック Rack Gears	○	○		○						○	○
はすば歯車 Herical Gears	○	○	○	○		○		○		○	○
ウォームギヤ Worm Gears	○	○	○	○	○	○	○	○	○	○	○
かさ歯車 Bevel Gears	○	○	○	○		○		○	○	○	○

お客様の図面、仕様書を基にご依頼、ご注文下さい。

弊社の設備の都合上、対応できない場合がございます。

We may not able to meet some requirements due to our capacity and equipments.

KG ギヤ・インフォメーション

KG Gear - Information

追加工について

Additional machining to KG standard gears

規格歯車の**追加工** 1個から対応いたします。



KG STOCK GEARS は 歯数、歯幅、穴径、などを各種取り揃え
広範囲のニーズにお応えできるものと考えておりますが、規格歯車の追
加工（二次加工）にてお客様の更なるニーズにお応えするために歯車
追加工を請け賜っております。

To meet customers' further demands, we make gears
with additional machining to our standard products.

お客様の図面を基にご依頼、ご注文ください。

When enquiries, please provide drawing with our standard product's catalogue No.

KG STOCK GEARS

Gears for Every Need.....

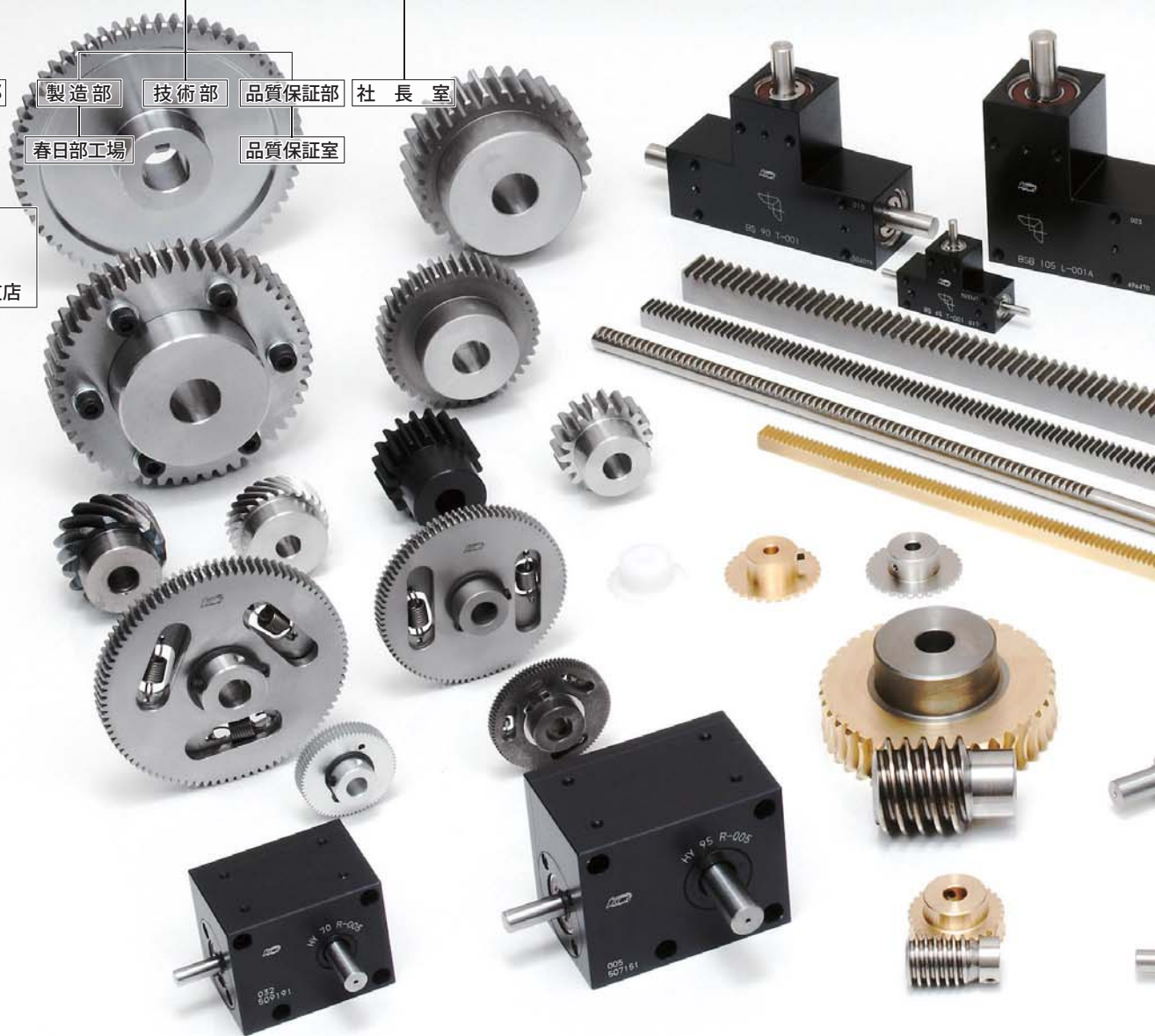
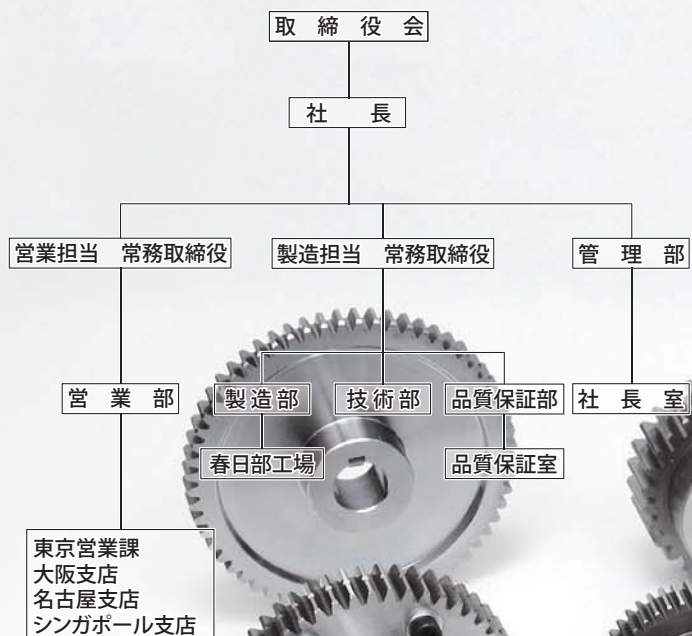

URL <http://www.kggear.co.jp/>

ご挨拶

KG カタログのご利用、誠に有難うございます。内容を一新し「KG2000」シリーズを発刊いたしました。お客様にとって「簡単」「便利」「一歩上」をコンセプトに、追加工の手間を省きそのまま使用できる新商品を掲載しております。このカタログをご活用いただき KG STOCK GEARS をご使用くださいますようお願い申し上げます。

代表取締役 井田 斉 昭
Managing Director Tadaaki Ida

A letter of greeting

We are pleased to publish the updated comprehensive catalogue of KG2000 series. We always fabricate our products based on the point of our valued customers.

Our concept of products has Easy, Convenient and advantage edge products. Features of our new products save customer's expenses on the additional machining work to the gears, and can use as it stands. Please make the full use of our features KG STOCK GEARS on the designing and purchasing.



KG ギヤ総合カタログの内容

KG STOCK GEARS インフォメーション
KG STOCK GEARS 寸法テーブル

The Contents of KG-General Catalogue.

- 1) Information of KG STOCK GEARS.
- 2) Edittion of Dimensions.

We design Gears to your requirements.

ギヤシステム (ギヤボックス)

33



ギヤシステムインフォメーション	34
HY-BOX	36
B-BOX (BSシリーズ)	38
B-BOX (BSBシリーズ)	40
B-BOX (BSHシリーズ)	42
B-SET	44
W-BOX	46
W-BOXインフォメーション	48

ノーバックラッシギヤ

49



ノーバックラッシギヤインフォメーション	50
NSUシリーズ m0.5 ステンレス	53
NSシリーズ m0.5/0.8/1 アルミニウム/S45C	54
NSGシリーズ m0.5/0.8/1 クロムモリブデン鋼	55
ASGシリーズ m1/1.5/2 クロムモリブデン鋼	56

歯研平歯車

57



SGシリーズ m0.5 クロムモリブデン鋼	58
SGシリーズ m0.8 クロムモリブデン鋼	62
SGシリーズ m1 クロムモリブデン鋼	65
SGシリーズ m1.5 クロムモリブデン鋼	70
SGシリーズ m2 クロムモリブデン鋼	73
SGシリーズ m2.5 クロムモリブデン鋼	76
SGシリーズ m3 クロムモリブデン鋼	78
歯研平歯車インフォメーション	80
SGEシリーズ m0.5 S45C	83
SGEシリーズ m0.8 S45C	84
SGEシリーズ m1 S45C	85
SGEシリーズ m1.5 S45C	86
SGEシリーズ m2 S45C	87
SGEシリーズ m2.5 S45C	88
SGEシリーズ m3 S45C	89

平歯車

91



m0.3	黄銅.....	92
m0.5	ポリアセタール.....	95
m0.5	ステンレス.....	100
m0.5	黄銅.....	102
m0.5	S45C.....	106
m0.75	ステンレス.....	112
m0.75	黄銅.....	114
m0.75	S45C.....	118
m0.8	S45C.....	120
m0.8	ポリアセタール.....	122
m0.8	ステンレス.....	126
m0.8	黄銅.....	130
m1	ポリアセタール.....	132
m1	ステンレス.....	140
m1	S45C.....	144
m1.25	S45C.....	172
m1.5	ポリアセタール.....	184
m1.5	ステンレス.....	186
m1.5	S45C.....	188
m2	ポリアセタール.....	214
m2	ステンレス.....	216
m2	S45C.....	218
m2.5	ポリアセタール.....	240
m2.5	S45C.....	242
m3	ポリアセタール.....	258
m3	S45C.....	260
m4	S45C.....	276
m5	S45C.....	277

内歯車

279



内歯車インフォメーション.....	279	
m0.5	黄銅.....	280
m0.8	黄銅.....	280
m1	S45C.....	281

精密歯研ラック

285



歯研ラック	m0.5/0.8/1/1.5	S45C	286
歯研ラック	m1/1.5/2/2.5/3	クロムモリブデン鋼	287
歯研CPラック	CP2/5	S45C	288
歯研CPラックピニオン	CP2/5	S45C	289
つなぎ用ゲージ			290

ラック

293



丸ラック	m0.5/0.75/0.8/1	ステンレス	294
BSラック	m0.3/0.5/0.75/0.8	黄銅	295
SUSラック	m0.5/0.75/0.8/1/1.5/2	ステンレス	296
S45Cラック	m1/1.25/1.5/2/2.5/3/4/5	S45C	298
CPラック	CP2/5/10	黄銅、S45C	302
CPラックピニオン	CP2/5/10	S45C	303

はすば歯車/ねじ歯車

307



はすば歯車インフォメーション	309
ポリアセタール	310
ステンレス	311
S45C	312

ウォーム・ギヤ

315



ウォーム・ギヤインフォメーション	316
m0.5	318
m0.8	320
m1	322
m1.25	330
m1.5	331
m2	338
m2.5	344
m3	348
m4	354
m5	356

マイタギヤ/ベベルギヤ 357



ベベルギヤインフォメーション	358		
ファインカットベベル	360		
B-LOCKインフォメーション	364		
B-LOCK	366		
MGH	368		
樹脂マイタギヤ/ベベルギヤ	m0.5/0.8/1/1.5	ポリアセタール ...	370
MIMマイタギヤ	m0.5/0.8/1	ステンレス	371
SUSマイタギヤ	m0.8/1/1.5/2/2.5/3	ステンレス	372
SUSベベルギヤ	m0.8/1/1.5/2	ステンレス	374
BSマイタギヤ/ベベルギヤ	m0.5/0.8/1	黄銅	375
S45Cマイタギヤ/ベベルギヤ	m0.5/0.8	S45C	376
スパイラルマイタギヤ/ベベルギヤ S45C	m1		378
	m1.5		380
	m2		383
	m2.5		386
	m3		388
マイタギヤ/ベベルギヤ S45C	m1		390
	m1.25		393
	m1.5		394
	m2		398
	m2.5		402
	m3		406
	m4		410
	m5		413

スプロケット 415



ピッチ 3.75	417
ピッチ 4.8	418
ピッチ 6.35	420

参考資料 422

Gear Systems 33



Information	34
HY-BOX	36
B-BOX(BS series)	38
B-BOX(BSB series)	40
B-BOX(BSH series)	42
B-SET	44
W-BOX	46
Information for W-BOX	48

Anti Backlash Spur Gears 49



Information	50
NSU series Module 0.5	53
NS series Module 0.5/0.8/1.0	54
NSG series Module 0.5/0.8/1.0	55
ASG series Module 1.0/1.5/2.0	56

Ground Spur Gears 57



SG series Module 0.5	58
SG series Module 0.8	62
SG series Module 1.0	65
SG series Module 1.5	70
SG series Module 2.0	73
SG series Module 2.5	76
SG series Module 3.0	78
Information	80
SGE series Module 0.5	83
SGE series Module 0.8	84
SGE series Module 1.0	85
SGE series Module 1.5	86
SGE series Module 2.0	87
SGE series Module 2.5	88
SGE series Module 3.0	89

Spur Gears

91



Module 0.3	Brass	92
Module 0.5	Poly Acetal	95
Module 0.5	SUS304	100
Module 0.5	Brass	102
Module 0.5	ISO C45	106
Module 0.75	SUS304	112
Module 0.75	Brass	114
Module 0.75	ISO C45	118
Module 0.8	ISO C45	120
Module 0.8	Pory Acetal	122
Module 0.8	SUS304	126
Module 0.8	Brass	130
Module 1.0	Pory Acetal	132
Module 1.0	SUS304	140
Module 1.0	ISO C45	144
Module 1.25	ISO C45	172
Module 1.5	Poly Acetal	184
Module 1.5	SUS304	186
Module 1.5	ISO C45	188
Module 2.0	Poly Acetal	214
Module 2.0	SUS304	216
Module 2.0	ISO C45	218
Module 2.5	Poly Acetal	240
Module 2.5	ISO C45	242
Module 3.0	Poly Acetal	258
Module 3.0	ISO C45	260
Module 4.0	ISO C45	276
Module 5.0	ISO C45	277

Internal Gears

279



Information	279	
Module 0.5	Brass	280
Module 0.8	Brass	280
Module 1.0	ISO C45	281

Ground Rack Gears 285



Ground Racks	286
Ground Racks	287
Ground CP Racks	288
Ground CP Rack Pinions.....	289
Gauge Racks	290

Rack Gears 293



Round Racks SUS304	294
Racks Brass	295
Racks SUS304	296
Racks ISO C45	298
CP Racks	302
CP Rack Pinions.....	303

Helical Gears and Screw Gears 307



Information	309
Poly Acetal.....	310
SUS304	311
ISO C45	312

Worms and Worm Wheels 315



Information	316
Module 0.5.....	318
Module 0.8.....	320
Module 1.0.....	322
Module 1.25	330
Module 1.5.....	331
Module 2.0.....	338
Module 2.5.....	344
Module 3.0.....	348
Module 4.0.....	354
Module 5.0.....	356

Miter Gears and Bevel Gears

357



Information	358
Fine Cut Spiral Miter Gears	360
Information for B-LOCK	364
B-LOCK.....	366
MGH.....	368
Module 0.5/0.8/1.0/1.5 Poly Acetal	370
Module 0.5/0.8/1.0/1.5/2.0/2.5/3.0 SUS304.....	371
Module 0.5/0.8/1.0 Brass.....	375
Module 0.5/0.8 ISO C45.....	376
Spiral Miter and Bevel Gears S45C Module 1.0	378
Module 1.5	380
Module 2.0	383
Module 2.5	386
Module 3.0	388
Miter and Bevel Gears S45C Module 1.0	390
Module 1.25.....	393
Module 1.5	394
Module 2.0	398
Module 2.5	402
Module 3.0	406
Module 4.0	410
Module 5.0	413

Sprocket

415



Pitch3.75	417
Pitch4.8	418
Pitch6.35	420

Reference Data	422
----------------------	-----

KG ギヤ・インフォメーション

KG Gear - Information

環境への取り組み

Our efforts to the environment

協育歯車工業株式会社では、地球規模の環境保全が全人類の最重要課題の一つであることを認識し、環境負荷の継続的減に努め、持続的に発展できる経済社会の実現に寄与しております。

RoHS 指令とは、6 物質 「鉛、水銀、カドミウム、六価クロム、特定臭素難燃剤 2 種 (PBB と PBDE)」 を使ってはいけないというものです。

2011 年 3 月より協育歯車工業株式会社の商品在庫はすべて RoHS 指令に対応した商品となりました。カタログの商品ページには RoHS 指令対応マークをつけております。

2006 年 11 月生産開始分より黄銅製品の中で素材が C3604B、C3771 の商品のカドミウム含有量をおさえた低カドミ材を採用することにより RoHS 指令に対応できる商品の提供を始めておりますが、流通在庫を含めたすべてが対応する商品ではございません。

「RoHS 指令対応品」のご要求がある場合にはその旨を明確にしてご指示をお願い致します。

KYOUIKU GEAR MFG CO LTD thinks that the global environmental conservation is one of most important issue for all mankind and makes an effort for continuous reduction of the environmental load. Therefore, we contribute to realize of the economic society, which can be developed continuously.

In the RoHS compliance that must not use exceeded contents on the regulation of the six substances, the Lead, Mercury, Cadmium, Hexavalent chromium and Polybrominated biphenyls (PBB), Polybrominated diphenyl ether (PBDE)

We have been produced our products with RoHS compliance since March 2011. We indicate the marks of RoHS compliance on our product' s pages in KG catalogue.

Since November 2006, we are supplying the products with RoHS compliance as we had adopted the material of low cadmium for ISO CuZn39Pb3 and CuZn38Pb2 in our brass products.

However, the distribution inventories are not compliant to all products.

Please inform us clearly when require for the products with RoHS compliance before ordering.

KG STOCK GEARS 商品の製造番号について

Regarding the production's number of KG products.

お客様のお手元にお届けする当社の商品には、商品記号と共に製造番号がラベルに印字されております。この製造番号を貴社にて記録し保管して頂く事により商品のトレーサビリティ（追跡調査）が可能となり、お届けした商品の各種お問合せに対しスピーディーな対応が可能となります。

Regarding the traceability number, we printed the commodity and production's numbers on the label of KG- products . In order for customers to trace the enquiry of KG products conveniently after purchased.

商品ラベルサンプル

Label sample of KG products



お客様にてトレーサビリティが必要な場合は、この製造番号を記録し保管して頂ければ幸いです。また当該商品のお問い合わせにつきましてはこの製造番号をご連絡下さい。

In case, customer needs to know the traceability of products, please check the production's number which printed on the label of KG products and inform to us.

2010年10月以降に発表された新商品の商品ラベルは上図左側の黄色のラベルに統一されております。

Regarding the new commodity number of our products, was indicated in yellow label at the top of left side on the packing box since October 2010.

特注品（オーダーメイド）について

Customize making gears.



KG-STOCK GEARS は 歯数、歯幅、穴径、ハブ径を各種取り揃え 広範囲のニーズにお答えできるものと考えております。設計をされる時は まず KG-STOCK GEARS に相当品が無いかご検討ください。KG-STOCK GEARS の中から適当な歯車を選定できない場合には お客様の設計図面をお送りください。

当社では精密小型規格歯車生産ノウハウを生かし 規格品以外の特注品も受け賜ります。価格、納期はご相談のうえ決めさせていただきます。

なお設計上不明の点がございましたら お気軽にご連絡ください。当社技術部はもちろん各支店にも経験豊富な技術サービス要員を配し 皆様のご要望にお答えいたします。

KG-STOCK GEARS has a wide selection of the variety with Number of Teeth, Face Width, Bore Diameters and Hub Diameter. Please select your suitable gear from our KG-catalogue when you work out a design.

With our professional engineers and our past experience, we are able to provide advice and accurate information to our customer for customizes make gears. Price and delivery lead time of the customize make gears are negotiable. Do not hesitate to call us for discussion.

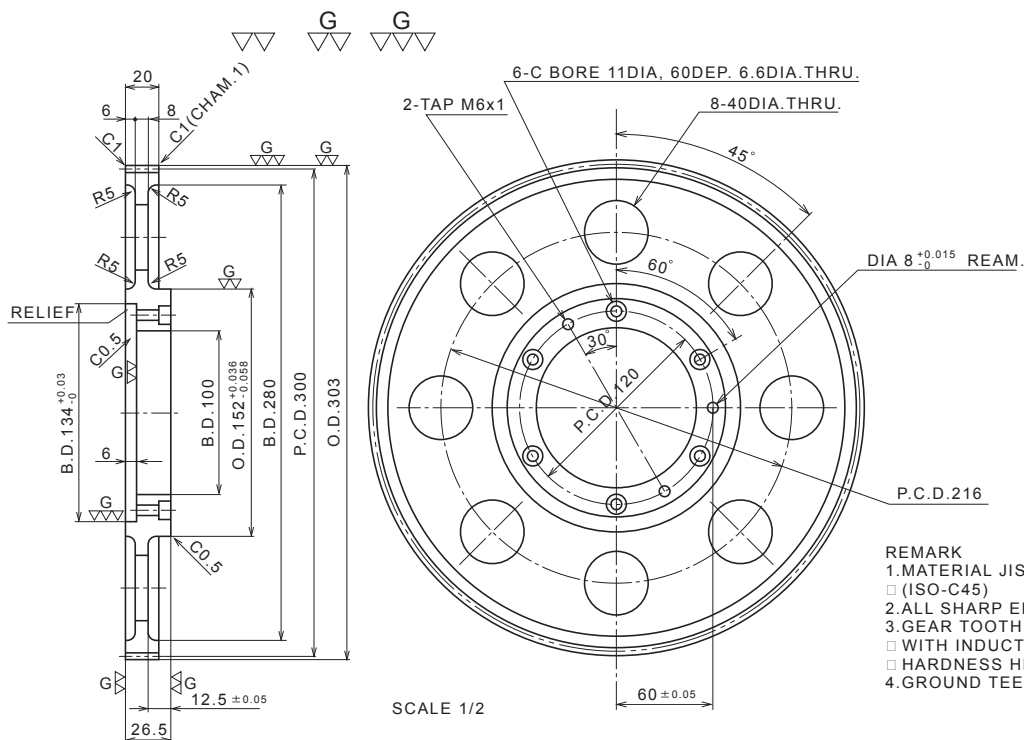

KG ギヤは JIS 記号を採用しています We have been adopting the symbol of JIS.

歯車の図面に関する各部寸法記号は 多岐にわたりますが KG ギヤでは JIS 規格、歯車の参考文献に使われている記号を採用しています。The Vocabulary of each dimension for the gear's drawing in various usages includes many different fields. KG has been adopting the symbols as there is reference literature of JIS standard and gear.

歯車記号と用語

The Vocabulary of Gear and Gear terms.

歯車の計算に使う歯車記号については JIS B0121-1999(歯車記号) に規定されています。歯車用語については JIS B 0102(歯車用語) に規定されています。

With regard to the Vocabulary of gear for gear calculation, define JIS B 0121-1999(Gear vocabulary).

With regard to the Gear terms, define JIS B 0102(Gear terms)

直線上及び円周上関係寸法 The relative dimension of the Rectilinear and Circumference

用語 Gear Terms	記号 Vocabularies
中心距離	a
円ピッチを総称する場合	when you call pitch
基準ピッチ	P
正面ピッチ	P_t
歯直角ピッチ	P_n
軸方向ピッチ	P_x
法線ピッチ	P_b
正面法線ピッチ	P_{bt}
歯直角法線ピッチ	P_{bn}
歯たけ	h
歯末のたけ	h_a
歯元のたけ	h_f
キャリバ歯たけ	h
かみ合い歯たけ	h'
歯厚を総称する場合	when you call tooth thickness
歯厚	s
基礎円上の歯厚	s_b
弦歯厚	\bar{s}
またぎ歯厚	w
歯溝の幅	e
頂げき	c
円周方向バックラッシ	j
法線方向バックラッシ	j_n
歯幅	b
有効歯幅	b' 又は b_w
リード	P_z
かみ合い長さ	length of path of contact
近寄りかみ合い長さ	g_f
遠のきかみ合い長さ	g_a
重なりかみ合い長さ	g_β
直径を総称する場合	when you call diameter
基準円直径	d
かみ合いピッチ円直径	d' 又は d_w
歯先円直径	d_a
基礎円直径	d_b
歯底円直径	d_f
半径を総称する場合	when you call radius
基準円半径	r
かみ合いピッチ円半径	r' 又は r_w
歯先円半径	r_a
基礎円半径	r_b
歯底円半径	r_f
曲率半径	ρ
円すい距離を総称する場合	when you call cone distance
円すい距離	R_c
中央円すい距離	R_m
内端円すい距離	R_i
背円すい距離	R_v
組立距離	A

角度関係寸法 The Angulars

用語 Gear Terms	記号 Vocabularies
圧力角を総称する場合	when you call pressure angle
基準圧力角	α
かみ合い圧力角	α' 又は α_w
工具圧力角	α_o
正面圧力角	α_t
歯直角圧力角	α_n
軸平面圧力角	α_x
ねじれ角を総称する場合	when you call helix angle
基準円筒ねじれ角	β
歯先円筒ねじれ角	β_a
基礎円筒ねじれ角	β_b
進み角を総称する場合	when you call lead angle
基準円筒進み角	γ
歯先円筒進み角	γ_a
基礎円筒進み角	γ_b
軸角	Σ
円すい角を総称する場合	when you call angle
ピッチ角	δ
歯先角	δ_a
歯底角	δ_f
歯末角	θ_a
歯元角	θ_f
正面接角	ϕ_a
重なり角	ϕ_β
全接角	ϕ_γ
冠歯車の角度ピッチ	τ
インボリュート α	$\text{inv } \alpha$

歯数及び比率 The Number of teeth and Gear ratio

用語 Gear Terms	記号 Vocabularies
歯数	z
相当平歯車歯数	z_v
条数又は小歯車歯数	z_1
歯数比	u
速度伝達比	i
モジュール	m
正面モジュール	m_t
歯直角モジュール	m_n
軸方向モジュール	m_x
かみ合い率	ε
正面かみ合い率	ε_a
重なりかみ合い率	ε_β
全かみ合い率	ε_γ
滑り率	σ
角速度	ω
線速度	v
回転数	n
転位係数	x
中心距離修正係数	y

ISO 規格と JIS 規格の整合化

Standardizing the coordination between ISO and JIS

はじめに

はじめに JIS 規格の ISO への整合化に伴い、多くの JIS 規格 (Technical report を含む) が 改訂や新規作成されつつあります。歯車に関する JIS 規格および JGMA 規格 (日本歯車工業会規格) についても順次改訂が行われますが このカタログ編集時はまだ JIS 規格および JGMA 規格のすべてが 改訂されたものとはいえ、廃止となった状態のままの規格もあります。しかしながら カタログの「歯車技術資料」編を編集するにあたり 旧となった JIS 規格や JGMA 規格は不可欠なものです。

そこで 極力新しい JIS 規格や JGMA 規格を採用して編集いたしました。新規規格の存在しないもの、または旧規格を使用しないと説明できない部分につきましては旧規格を使用し 規格番号の先頭に「旧」の文字を付記しました。また「歯車の寸法」編については 新旧規格を並列表記している部分もございます。

当社では ISO 規格、JIS 規格および JGMA 規格などの改訂状況に注目しながらカタログの改訂を行いますが これらの規格が制定、改訂されても、本カタログに引用されている内容の改訂が出来ない場合がありますので ご了承ください。

Firstly, as standardizing at the coordination of ISO standard from JIS standard, most of JIS-standard (included Technical report) has been making revision and replacement.

In due time JIS standard and JGMA standard (Japan Gear Manufacturers Association) for the gears shall be revised to a new edition as time to come. However JIS standard and JGMA standard are not complete and some standard was abolished when we started the new edition of KG catalogue. However an old JIS and JGMA standard are essential reference of gears for KG-new catalogue.

Therefore we had adopted the latest JIS and JGMA standard as latest as possible in our new edition KG-catalogue. However if we found inexplicability and nonexistence standard, we introduced the old and new standards to our new edition KG-catalogue.

With respect to the new edition of ISO, JIS and JGMA standards, new edition KG-catalogue is unable to adopt the latest revised ISO, JIS and JGMA standards. We seek your understanding for our latest edition of KG-catalogue.

KG STOCK GEARS の精度について

Precision of KG STOCK GEARS.

これまで永年にわたり用いてきた JIS B1702:1995 確認 (平歯車及びはすば歯車の精度) が廃止され、JIS B 1702-1:1998 (円筒歯車—精度等級 第一部:歯車の歯面に関する誤差の定義および許容値) および JIS B 1702-2: 1998(円筒歯車—精度等級 第2部: 両歯面かみあい誤差および歯溝の振れの定義ならびに精度許容値) の2つの規定に分割されて制定されました。

これらの内容について旧 JIS B 1702 と比較すると、モジュールや基準円直径 (旧 JIS では基準ピッチ円直径) の区分が異なっている為に例えば旧 JIS 4 級が新 JIS では何級に相当するかについて詳細に対応させることはできません。

おおよその目安として

新 JIS 精度等級 = 旧 JIS 精度等級 + 4 (級)

といわれていますが 比較的歯数の小さい範囲または比較的歯数の大きい範囲では上記の目安が適用できない部分があります。

The Two Regulations had enacted that JIS B 1702-1:1998 (Cylindrical gears - Precision and Classification Article 1: Definition of Error and Amount of Permissible for a Gear flank) and JIS B 1702-2:1998 (Cylindrical gears - Precision and Classification Article 2: Error of Tooth to Tooth Working, Definition of Run out and Amount of Precision) in place of JIS B 1702: 1995, confirmed (Precision for the Spur and Helical gears) was discontinued after so many years used.

When new JIS compared with old JIS B 1702, the new JIS is unable to be equivalent to the Old JIS class 4 detail, due to different classification of Module and Reference diameter (call Pitch Diameter of old JIS).

The rough outline of the theory is New JIS precision class = Old JIS precision class plus(+) 4, however comparatively range of small or big number of teeth are unable to cover the above classification.

新旧歯車用語の比較例 Comparison of new and old gear's terms

JIS B0102 : 1999	旧 JIS B0102 : 1993
基準円直径 reference diameter	基準円ピッチ円直径 pitch diameter
歯たけ tooth depth	全歯たけ whole depth
かみ合い歯たけ working tooth depth	有効歯たけ working depth
ピッチ角 pitch angle	ピッチ円すい角 pitch cone angle
歯先角 tip angle	歯先円すい角 tip cone angle
歯底角 root angle	歯底円すい角 root cone angle
(かさ歯車の) ねじれ角 spiral angle	(かさ歯車の) ねじれ角 helix angel
(かさ歯車の) 組立距離 locating distance	(かさ歯車の) 位置決め距離 mounting distance

本カタログの『歯車の寸法』編については、新 JIS 規格に変更されていない箇所があります。

Some of the old standard still remain unchanged in our new KG-catalogue for the Dimensions of the Gears.

KG STOCK GEARS の精度等級について Regarding the system of accuracy for KG STOCK GEARS.

KG 歯研平歯車の精度は、『新 JIS5 級相当』です。
System of accuracy of KG-Ground Spur Gear is equivalent to JIS B1702-1 class 5.

KG ギヤ S45C 平歯車の精度は『新 JIS 8 ~ 9 級』です。
System of accuracy of KG- Spur Gear with ISO C45 is equivalent to JIS B1702-1 class 8-9.

JIS B1702-1 において定められた歯車の測定項目における KG ギヤの精度等級は、およそ下記のとおりとなっております。
System of accuracy of KG-STOCK GEARS based on JIS B 1702-1 standards are as follows.

単一ピッチ誤差 Single pitch deviation	新 JIS7 級相当 JIS B1702-1 class 7
累積ピッチ誤差 Total cumulative deviation	新 JIS8 級相当 JIS B1702-1 class 8
歯形誤差 Tooth profile deviation	新 JIS8 級相当 JIS B1702-1 class 8
歯溝の振れ Run out	新 JIS8 級相当 JIS B1702-1 class 8

歯形誤差 歯溝の振れを常に新 JIS8 級に維持すれば新 JIS8 級と言えるわけですが、規格歯車を経済的に製造する上で問題が生じてまいります。従いまして現在では、JIS の等級分類に従い KG ギヤは『新 JIS 8 級相当』となっております。

Although we are able to provide the gear with JIS B1702-1 class 8 for tooth profile deviation and runout. In order to maintain the demand so that economically price to be as competitive as possible. Therefore, we manufacturing by equivalent at the JIS B1702-1 class 8 gear.

S45C 以外の平歯車、ヘリカルギヤ

Regarding the system of accuracy of Spur and Helical gears with materials of SUS 304, Brass and Poly Acetal.

SUS 平歯車、ヘリカルギヤ Spur and Helical gears with SUS-stainless steel	新 JIS9 級 JIS B1702-1 class 9
黄銅（カシメ品は除く）平歯車 Spur gears with Brass except riveted type.	新 JIS9 級 JIS B1702-1 class 9
ポリアセタール（射出品は除く）平歯車、ヘリカルギヤ Spur and Helical gears with Poly Acetal except Injection molded type.	新 JIS9-10 級 JIS B1702-1 class 9 - 10

KG マイタ、ベベルギヤの精度

System of accuracy of KG-Miter and Bevel gears.

SCM435 ファインカットベベルギヤ Fine Cut Miter Gear with ISO 34CrMo4, 42CrMo4 steel	JIS2 級 JIS B 1704 class 2
S45C マイタ、ベベルギヤ Miter and Bevel gears with C45-carbon steel.	JIS 3 級 JIS B 1704 class 3
S45C マイタ、ベベルギヤ高周波焼入れ品 Miter and Bevel gears completed Induction harden.	JIS 4 級 JIS B 1704 class 4
SUS304 マイタ、ベベルギヤ Miter and Bevel gears with SUS-stainless steel.	JIS4 級 JIS B 1704 class 4
黄銅マイタ、ベベルギヤ Miter and Bevel gears with Brass.	JIS 4 級 JIS B 1704 class 4
ポリアセタールマイタ、ベベルギヤ（射出品は除く） Miter and Bevel gears with Poly Acetal except Injection molded type.	JIS5-6 級 JIS B 1704 class 5 or 6

KG ポリアセタール商品の穴径の精度

Fitting tolerance of bore dimensions for KG products with Poly Acetal.

ポリアセタール切削加工品（射出品は除く）の穴径寸法公差 加工管理公差 H9
ポリアセタール商品は 素材の特性上、経年変化、温度変化等により寸法変化が occurs。アセタール製品の穴径寸法の加工管理公差は H9 になっておりますが KG STOCK GEARS の宿命で生産後一時在庫となる関係上、お客様のお手元にお届けする際にはすでに寸法変化を起こしている事があります。

Fitting tolerance of bore dimensions for KG Miter and Bevel gears with Poly Acetal except Injection molded types are by the working control's tolerance of H9. The working control H9 for the gears with Poly Acetal maybe affected to change the dimension's tolerance due to the characteristic of secular change and fluctuation of temperature that may occur after our production in a period of storage time.

詳しくは歯車技術資料をご参照ください。

For more details of system of accuracy, refer to KG-Technical Data.

KG ギヤ・インフォメーション

KG Gear - Information

KG ギヤの寸法記号

KG ギヤ寸法記号一覧表 (1) The vocabulary and terms of KG-gear (1)

KG ギヤのタイプと簡易図面 Simple drawings and Types of KG STOCK GEARS.		名称 Gear terms.	記号 Vocabularies
平歯車・ヘリカルギヤ Spur and Helical gears.		歯先円直径 Tip diameter d_a 基準円直径 Reference diameter d ハブ外径 Hub diameter d_h 穴径 Bore diameter d_a 全長 Overall length l 歯幅 Face width b ハブ長さ Hub projection l_h	
内歯車 (インターナルギヤ) Internal gears.		歯先円直径 Tip diameter d_a 基準円直径 Reference diameter d 歯底円直径 Root diameter d_f 外径 Outside diameter of Ring D 歯幅 Face width b	
ラック Racks		全長 Overall length l かみ合い高さ Datum line h'' 歯幅 Face width b 高さ Overall Thickness h 軸径 Shaft diameter d_h 有効かみ合い長さ Effective Datum length b_e 柄長さ Length of stem l_h	
ラックとピニオン Racks and Pinions		組み立て距離 Locating distance a	

KG ギヤ寸法記号一覧表 (2) The vocabulary and terms of KG-gear (2)

KG ギヤのタイプと簡易図面 Simple drawings and Types of KG STOCK GEARS.	名称 Gear terms.	記号 Vocabularies
<p>ウォーム Worms gears</p>	<p>歯先円直径 Tip diameter d_a</p> <p>基準円直径 Reference diameter d</p> <p>ハブ外径 Hub diameter d_h</p> <p>穴径 Bore diameter d_i</p> <p>全長 Overall length l</p> <p>歯幅 Face width b</p> <p>ハブ長さ Hub projection l_h</p>	
<p>ウォームホイール Worm wheels</p>	<p>歯先円直径 Tip diameter d_a</p> <p>のどの直径 Throat diameter d_r</p> <p>嚙合ピッチ円直径 Pitch diameter d</p> <p>ハブ外径 Hub diameter d_h</p> <p>穴径 Bore diameter d_i</p> <p>全長 Overall length l</p> <p>歯幅 Face width b</p> <p>ハブ長さ Hub projection l_h</p> <p>リム内径 Dimension of Rim d_i</p> <p>ウェブ厚さ Thickness of Web b_w</p> <p>嚙合中心距離 Center distance A</p>	
<p>マイタ、ベベルギヤ Miter and Bevel gears</p>	<p>組立距離 Locating distance A</p> <p>歯先円直径 Tip diameter d_a</p> <p>基準円直径 Reference diameter d</p> <p>ハブ外径 Hub diameter d_h</p> <p>穴径 Bore diameter d_i</p> <p>歯先角 Tip angle δ_a</p> <p>ピッチ角 Pitch angle δ</p> <p>歯幅 Face width b</p> <p>ハブ長さ Hub projection l_h</p> <p>全長 Overall length l_w</p>	
<p>スプロケット Sprockets</p>	<p>外径 Tip diameter d_a</p> <p>基準円直径 Reference diameter d</p> <p>ハブ外径 Hub diameter d_h</p> <p>穴径 Bore diameter d_i</p> <p>全長 Overall length l</p> <p>歯幅 Face width b</p> <p>ハブ長さ Hub projection l_h</p> <p>歯底円直径 Root diameter d_f</p>	

許容伝達動力表の解説

Interpretation of Allowable capability torque table.

本カタログに記載されております許容伝達動力表「曲げ強さ」「歯面強さ」「許容ウオームホイールトルク歯面強さ」のテーブルは JGMA の式（日本歯車工業会規格）を採用しております。（樹脂歯車を除く）。歯車の種類、モジュールサイズにより、JGMA の式の適用外であるため参考値になります。なお 歯車の種類とモジュールサイズの区分は表 1 をご参照ください。

The Bending Strength, Surface Durability and Allowable Transfer Capability Torque of Worm Wheel are introduced by using JGMA (Japan Gear Manufacturers Association) formula except Poly Acetal material. This JGMA formula does not apply to every gear, or some is reference only. Therefore refer to the below classification of reference 1 for Kind of the gear and Module size.

JGMA の式の適用範囲抜粋（表 1）

Applicable range for JGMA formula (Reference 1)

歯車の種類 Kind of Gears	JGMA 規格 No JGMA standard	モジュールサイズ Range of Module	ピッチ円直径 Pitch Diameter
平歯車 Spur gear	JGMA401 - 01	1.5 ~ 25mm	ピッチ円直径 25 ~ 3200mm Pitch diameter
はすば歯車 Helical gear	JGMA402 - 01		
すば傘歯車 Bevel gear	JGMA403 - 01	外端正面モジュール 1.5 ~ 25mm Outertransverse module	外端ピッチ円直径 1600mm 以下 Below 1600mm of Outer pitch diameter
まがりば傘歯車 Spiral bevel gear	JGMA404 - 01		外端ピッチ円直径 1000mm 以下 Below 1000mm of Outer pitch diameter
ウオームギヤ Worm gear pair	JGMA405 - 01	軸方向モジュール 1.0 ~ 25mm Metric axial module	ホイールのピッチ円直径 900mm 以下 Below 900mm Pitch diameter of Worm wheel

(1) 平歯車およびはすば歯車の曲げ強さ、歯面強さ

Bending Strength and Surface Durability for Spur and Helical gears.

項目 Descriptions	材質 Material	SCM435	S45C		(1) SUS304	(1) C3604B	アセタール Poly Acetal
		高周波焼入れ Induction hardening	-	高周波焼入れ Induction hardening			
使用計算式 Calculation		平歯車およびはすば歯車の曲げ強さ計算式 JGMA 401 - 01 Calculation for Bending strength of Spur and Helical gears as JGMA 401-01.					ルイスの式 Louis formula
		平歯車およびはすば歯車の歯面強さ計算式 JGMA 402 - 01 Calculation for Surface durability of Spur and Helical gears as JGMA 402-01.					
相手歯車 Matching gear		同一歯数および同一材質 The same number of teeth and same material					-
許容曲げ応力 Stress of Allowable Bending	$:\sigma F_{lim}$	36.5kgf/mm ²	21.0kgf/mm ²	25.0kgf/mm ²	10.5kgf/mm ²	4.2kgf/mm ²	3.4kgf/mm ²
許容ヘルツ応力 Stress of Allowable Hertz	$:\sigma H_{lim}$	121kgf/mm ²	-	106.5kgf/mm ²	-	-	-
寿命期間中に歯がかみあう回数 The number of times of engagement between two gears during life span		10 ⁷ 回以上 Above 10 to the power of 7.				(K _i =1.0)	-
原動機側からの衝撃 Impact from motor side.		均一負荷 Flat load					-
被動機械からの衝撃 Impact from load		中程度の衝撃 Average impact				(K _i =1.25)	-
潤滑方式および油の粘度 Lubricating system and Oil viscosity		油潤滑 100 cSt (50°C) Oil Lubrication.				(Z _i =1.0)	-
歯車の支持方法 Method of supporting gear		両軸受けに対称に両側支持 Double supporting with plane symmetry to both bearing					-
歯元曲げ破損に対する安全率 Safety Factor of Tooth Breakage	$:\sigma F$	1.2					-
歯面強さに対する安全率 Factor of safety at Surface strength	$:\sigma H$	1.15					-
荷重方向 Load direction		荷重の方向は一定					-

荷重方向が正逆転の場合（ラックピニオン含む）と 中間ギヤは各種歯車の許容伝達表の値の 2/3 となります。

許容伝達動力表の歯面強さは 遊歯歯車や大歯車と 2ヶ所所がかみ合う小歯車（中間歯車）には適用できません。

注 (1) JGMA401-01 と JGMA402-01 に規定されていない規格は JGMA6101-01 と JGMA6102-01 に準拠しております。

本カタログに記載されております許容伝達動力表の曲げ強さに対して回転数 n = 100 [min⁻¹] における許容伝達トルク値 [N.m] を各表に表示しております。（表示範囲：モジュール m1-5, 材質 S45C）

Regarding the amount of allowable transfer capability, load direction is the reversible and the middle gear become 2/3 (including rack pinion).

Surface Durability in Allowable transfer capability table that the formula does not apply to Idler gear or mid gear engaged with 2 gears.

Note (1) Sub standard JGMA401-01 and JGMA402-01 equivalent to JGMA 6101-01 and JGMA6102-01.

The Amount of Allowable transfer torque [N.m] at the number of revolution per minute n=100 [N.m] to each reference compare with Bending strength of Allowable transfer capability table (Range: Module 1.0 to 5.0 with ISO C45 carbon steel) in KG-catalogue.

(2) かさ歯車の曲げ強さ、歯面強さ

Bending strength and Surface durability for Bevel gears.

項目 Descriptions	材質 Material	SCM435		S45C		(2) SUS304
		高周波焼入れ Induction hardening	—	高周波焼入れ Induction hardening		
使用計算式 Calculation		かさ歯車の曲げ強さ計算式 JGMA 403 - 01 Calculation for Bending strength of Bevel gears as JGMA 403-01.				
		かさ歯車の歯面強さ計算式 JGMA 404 - 01 Calculation for Surface durability of Bevel gears as JGMA 404-01.				
相手歯車 Matching gear		選定された商品の相手歯車 Nominative Matching gear.				
許容曲げ応力 Stress of Allowable Bending	: σF_{lim}	31.0kgf/mm ²	19.0kgf/mm ²	22.0kgf/mm ²		10.5kgf/mm ²
許容ヘルツ応力 Stress of Allowable Hertz	: σH_{lim}	109.0kgf/mm ²	54.0kgf/mm ²	85.0kgf/mm ²		—
寿命期間中に歯がかみあう回数 The number of times of engagement between two gears during life span		10 ⁷ 回以上 Above 10 to the power of 7.				
原動機側からの衝撃 Impact from motor side.		均一負荷 Flat load				
被動機械からの衝撃 Impact from load		中程度の衝撃 Average impact				
潤滑方式および油の粘着度 Lubricating system and Oil viscosity		油潤滑 100 cSt (50°C) Oil Lubrication.				
軸、歯車箱などの剛性 Stiffness of gear shaft and gearbox.		普通 Standard				
歯車の支持状態 Supporting condition of the gear		両歯車片持支持 Overhang condition				
		(K _{Mβ} =1.8)		(K _{Mβ} =2.1)		
歯元曲げ破損に対する信頼度係数 : K _R Coefficient of reliability of Tooth Breakage		1.2				
歯面強さに対する信頼度係数 : C _R Coefficient of reliability at Surface strength		1.15				
荷重方向 Load direction		荷重の方向は一定 One-way direction				

荷重方向が正逆転の場合は各種歯車の許容伝達表の値の2/3となります。

注(2) JGMA403-01とJGMA404-01に規定されていない規格はJGMA6101-01とJGMA6102-01に準拠しております。

Regarding the amount of allowable transfer capability, load direction is the reversible and the middle gear become 2/3.

Note (2) Sub standard JGMA403-01 and JGMA404-01 equivalent to JGMA 6101-01 and JGMA6102-01.

(3) 円筒ウォームギヤ歯面強さ

Surface durability of Cylindrical worm gear pair.

項目 Descriptions	ホイールの材質 Material of Wheel	C3604B 黄銅 Brass	FC200 普通铸铁 Cast iron	CAC702 アルミニウム青銅 Aluminum Bronze
	使用計算式 Calculation		円筒ウォームギヤの強さ計算式 Calculation for Surface strength of Cylindrical worm gear pair.	
歯面強さに対する許容応力係数 : σF_{lim} Coefficient of Allowable Stress at Surface strength		0.42	0.63	0.56
期待寿命時間 Effective life period		26,000 時間 26,000 hours		
油潤滑 Oil Lubrication.		歯車用極圧添加剤の入った適正な粘土の潤滑油を使用 Provided extreme additive lubricant oil with proper viscosity.		
潤滑方式 Lubricating system		油浴潤滑 Oil bath Lubrication		
歯当たり Surface contact		JIS B 1741 (歯当たり) の区分 A に相当する歯当たり This Surface contact is equivalent to classification A of JIS B1741 (Surface contact)		
起動状況 Starting condition		起動時のトルクが定格トルクの200%以下で1時間あたりの起動回数は2回未満 Starting torque should below 200 % from rating torque and the number of starting time should less than 2 times.		
原動機側からの衝撃 Impact from motor side.		均一負荷 Flat load		
被動機械からの衝撃 Impact from load		均一負荷 Flat load		

荷重方向が正逆転の場合は各種歯車の許容伝達表の値の2/3となります。

注(1) JGMA403-01とJGMA404-01に規定されていない規格はJGMA6101-01とJGMA6102-01に準拠しております。

Regarding the amount of allowable transfer capability, load direction is the reversible and the middle gear become 2/3.

Note (1) Sub standard JGMA403-01 and JGMA404-01 equivalent to JGMA 6101-01 and JGMA6102-01.

各歯車の曲げ強さ及び歯面強さ計算式の詳細につきましては本カタログの「歯車の基礎と関連資料」をご参照ください。

KG CALMET for Window(歯車諸元計算、強度計算ソフト)を使用する事により容易に計算する事が出来ます。

許容伝達動力表の曲げ強さの使用例

歯面強さの確認も行う必要があります。

While examination of Bending strength from the Allowable transfer capability table, Surface strength check are necessary too.

規格平歯車の許容伝達トルクを求める

To calculate Allowable transfer torque of KG STOCK GEARS.

平歯車の使用条件より規格歯車を選定する

To select KG-STOCK GEARS from usage condition of Spur gear.

計算例 1. 規格歯車の許容伝達トルク：T [N.m] を求める。

For example 1. To calculate Allowable transfer torque: T[N.m]

(1) 規格歯車の商品記号 S2S 40B-2016F を使用する場合

- 1) モジュール $m=2$ 3) 歯幅 20[mm]
2) 歯数 $z=40$ 4) 穴径 16[mm]

(2) 歯車の使用条件

- 1) 平歯車の歯数比 $u=1:1$
2) 平歯車の回転数 $n=100[\text{min}^{-1}]$
3) 平歯車の強度計算に関する条件 (JGMA401-01 を参照)
a) 歯車は歯車箱内で油谷潤滑とする。
b) 歯車軸の軸受けは歯車の両側で支持する。
c) 原動機側から歯車に均一負荷を受ける。
d) 被動機械から歯車に中程度以下の衝撃を受ける。
e) 歯車が寿命期間中にかみ合う回数は 10^7 回以下とする。

(3) カタログの許容伝達動力表 (kW) 曲げ強さにより許容伝達トルクを求める。

- 1) (1) (2) の条件にてカタログの許容伝達動力表 (kW) 曲げ強さより数値を読み取る。

$$KW=1.61[\text{kW}]$$

- 2) 動力 kW[kW] をトルク [N.m] に換算する

$$T=9549.7 \frac{\text{kW}}{n} \quad n=100 \text{ より}$$

$$T=9549.7 \times \frac{1.61}{100}=153.75[\text{N.m}]$$

よって選定した規格歯車 S2S 40B-2016F の許容伝達トルクは $T=153.75[\text{N.m}]$ となります。

この歯車は以上の使用条件の場合、入力トルク $T=153.75[\text{N.m}]$ までの範囲でご使用いただけます。

(1) For example, calculating KG – STOCK GEAR S2S 40B-2016F

- 1) Module $M2.0$ 3) Face width 20mm
2) No. of teeth $z=40$ 4) Bore 16mm

(2) Usage condition of Spur gear.

- 1) Gear ratio of Spur gear $u=1:1$
2) The number of revolution $n=100 / \text{min}$
3) Providing conditions with usage of gear for strength calculation. Please refer to Calculation for Bending strength of Spur and Helical gears as JGMA401-01.
a) The gear is in gearbox with lubricant oil.
b) Bearing in gearbox should position on both sides. Bearings are plane symmetry.
c) Receiving load from a motor side is a flat load or less.
d) Receiving impact from a load side is an Average or less.
e) During gear life period, the number of times for set of gear engagement is below 10^7 times.

(3) To calculate Allowable torque from Allowable transfer capability table (kW) with Bending strength in KG-catalogue.

- 1) Base on Usage Candition of Spur Gear stated above (1) and (2) that obtain a numerical value from Allowable transfer capability table in KG-catalogue.

$$KW=1.61[\text{kW}]$$

- 2) Convert to Torque [N.m] from power kW[kW]

$$\text{Gained } T=9549.7 \frac{\text{kW}}{n} = 9549.7 \times \frac{1.61}{100}=153.75[\text{N.m}]$$

Therefore selected S2S 38B-2016F as Allowable transfer torque $T=153.75[\text{N.m}]$

This gear can be used unless exceed range of Input torque $T=153.75[\text{N.m}]$

計算例 2. 平歯車の条件により規格歯車を選定する。

For example 2. To select KG STOCK GEARS from conditions of Spur gear.

(1) 歯車の使用条件 (お客様の仕様)

- 1) 平歯車に作用する最大の呼びトルク $T=142$ [N.m] (安全率を含む)
- 2) 平歯車の回転数 $n=100$ [min^{-1}]
- 3) 平歯車の歯幅 $b=10-30$ [mm]
- 4) 平歯車の軸間距離 $a=70-100$ [mm]
- 5) 平歯車の歯数比 $u=1:1$
- 6) 平歯車の強度計算に関する条件 (JGMA401-01 を参照)
 - a) 歯車は歯車箱内で油谷潤滑とする。
 - b) 歯車軸の軸受けは歯車の両側で支持する。
 - c) 原動機側から歯車に均一負荷を受ける。
 - d) 被動機械から歯車に中程度以下の衝撃を受ける。
 - e) 歯車が寿命期間中にかみ合う回数は 10^7 回以下とする。

(2) 平歯車に作用する軸トルク : T [N.m] を許容伝達動力表 (kW) 曲げ強さの動力 : kW [kW] に換算する。

$$kW = \frac{T \cdot n}{9549.7} = \frac{142 \times 100}{9549.7} = 1.487 \text{ [kW]}$$

(3) 規格歯車より選定する

1) 平歯車の選定条件

- a) モジュール $m=2$ とする (例)
- b) 歯数 中心距離 : $a=70-100$ [mm]
歯数比 $u=1:1$
より 35-50 [枚] の間で検討する。
- c) 歯幅 $b=10-30$ [mm]
- d) 回転数 $n=100$ [min^{-1}]
- e) 動力 $kW=1.487$ [kW]

2) 平歯車の選定。

- a) カタログより平歯車 モジュール : $M=2.0$ 歯数 : $z=35-50$ [枚] のページを参照
- b) 許容伝達動力表 (kW) 曲げ強さの表より、
回転数 $n=100$ [min^{-1}] の欄を参照する
動力 $kW=1.487$ [kW] 以上の数値となる歯数および歯幅を検索する。

以上により

歯数 : $z=38$ [枚] 歯幅 : $b=20$ [mm] 材質 : S45C の条件にて

許容伝達動力 : $kW=1.51$ [kW] 表より

呼び動力 : $kW=1.487$ [kW] 計算結果より

(許容伝達動力) \geq (呼び動力) となる事がわかる

c) 該当規格歯車商品記号

S2S 38B-2016F 以上のサイズが推奨されました。

英訳は、次のページを参照してください。

Please refer to the English translation that continued on the next following page.

(1) Usage condition of Spur gear. (Give us the specification by customer)

- (1) Action to Spur gear with maximum normal torque is $T=142$ [N.m] included factor of safety.
- (2) The number of revolution $n=100$ / min
- (3) Face width of Spur gear $b=10-30$ [mm]
- (4) Center distance of Spur gear $a=70-100$ [mm]
- (5) Gear ratio of Spur gear $u=1:1$
- (6) Providing conditions with usage of gear for strength calculation. Please refer to Calculation for Bending strength of Spur and Helical gears as JGMA401-01.
 - a) The gear is in gearbox with lubricant oil.
 - d) Bearing in gearbox should position on both sides. Bearings are plane symmetry.
 - c) Receiving load from a motor side is a flat load or less.
 - d) Receiving impact from a load side is an Average or less.
 - e) During gear life period, the number of times for set of gear engagement is below 10^7 times.

(2) Convert to Power kW [kW] of Allowable transfer capability table with Bending strength from axial torque T [N.m] with action to Spur gear.

$$kW = \frac{T \cdot n}{9549.7} = \frac{142 \times 100}{9549.7} 1.487 [kW]$$

(3) To select KG-STOCK GEARS

- 1) Selected condition of Spur gear.
 - a) Module $M=2.0$ (eg)
 - b) No. of teeth Center distance $a=70-100$ [mm]
Gear ratio $u=1:1$

Therefore we verify the No. of teeth of 35-50z.

- c) Face width $b=10-30$ [mm]
- d) The number of revolution $n=110$ [min⁻¹]
- e) Power $kW=1.487$ [kW]

2) Selection of KG STOCK GEARS

- a) Please refer the page for Module 2.0 and Number of teeth 35 to 50 from the catalogue of KG-Spur gear.
- b) Refer to Allowable transfer capability table (kW) of Bending strength.

The number of revolution
Observing the column of $n=100$ [min⁻¹] for your selection.
Power
Look up numerical value of $kW=1.487$ [kW] or more
Concluded,
On condition that Number of teeth: $z=38$ [z], Face width: $b=20$ [mm] and material: S45C
Obtained $kW=1.51$ [kW] from Allowable transfer capability table.
Compared with action to Spur gear with maximum normal torque is $T=142$ [N.m] included factor of safety.
Can be judged (Allowable transfer capability) \geq (Normal power).
- c) Can be searched your suitable S2S 38B-2016F as our recommendation only.

動力の換算式 The Conversion formula of Power

1) トルクを求める Calculate Torque from

$$T: \text{トルク (Torque) [N} \cdot \text{m]} \\ T = 9549.7 \frac{kW}{n} \Leftrightarrow kW = \frac{T \cdot n}{9549.7}$$

$$T: \text{トルク (Torque) [kgf} \cdot \text{m]} \\ T = 973.8 \frac{kW}{n} \Leftrightarrow kW = \frac{T \cdot n}{973.8}$$

$$T: \text{トルク (Torque) [kgf} \cdot \text{m]} \\ T = \frac{F_t \cdot r}{1000} \Leftrightarrow F_t = \frac{1000 \cdot T}{r}$$

2) SI 単位への換算 Convert to Standard Integer

$$1 [\text{kgf} \cdot \text{m}] = 9.80665 [\text{N} \cdot \text{m}] \\ 1 [\text{W}] = 1 [\text{N} \cdot \text{m/s}]$$

ここに n : 回転速度 Revolution per minute [min⁻¹]
Hereby r : 基準円半径 Reference radius [mm]
(転位歯車の場合はかみ合いピッチ円半径)
(In case of Shifted gears as working Radius)

T : トルク Torque [N · m]

kW : 動力 Power [kW]

F_t : 正面におけるかみ合いピッチ円上の円周力 [N]
Tangential Force of pitch circle [N]

お客様が歯車を使用する開発設計、設計変更において歯車のことでお困りになった事はございませんか。その際はお気軽にご連絡下さい。

Q：KGは どこまでやるの？

A：当社では

小型精密歯車のことはKGにお任せ下さい。

- ◎ KG STOCK GERS の提供
- ◎ 特注品（オーダーメイド）の提供
 - ・ お客様の仕様による歯車設計のサポート
 - ・ 歯車ユニットとしての対応

お客様の多様なニーズにお応えします。



『例えば』

かさ歯車の採用を考えているが、**ユニット**として設計したい。

お問い合わせ下さい！

お客様のご要望をお知らせ下さい。

- ・ 使用条件・・・入力トルク、入力回転数、要求精度
- ・ 使用環境
- ・ ユニットの形状、サイズ

当社のB-BOXシリーズのノウハウを活かして、経験豊富な技術サービススタッフがバックアップさせていただきます。

KG ギヤ・インフォメーション

KG Gear - Information

追加工の注意点

KG STOCK GEARS の追加工の注意点

Additional machining to the KG STOCK GEARS.

KG ギヤは1シリーズに数種の穴径を用意しております。KG ギヤ精度、性能をご利用頂くためには穴の追加工は、なるべく避けてください。但し、穴の追加工が必要となる場合はFタイプ（-記号が付いたもの）をご利用ください。

KG STOCK GEARS have variety of bore size in each number of teeth. We make the best use of the precision and quality performance of KG STOCK GEARS to customers. Please install KG STOCK GEARS without any additional machining because KG STOCK GEARS are complete finished gears.

However if additional machining on the KG STOCK GEARS are necessary, please select F-type of KG STOCK GEARS that indicate a minus (-) sign in our KG Gears Catalogue Part Number.

なまづめスクロールチャック、三つ爪スクロールチャック等を使い芯だしを行ってください。

In order to prevent scratches and damage to the gear, provide scroll chuck without mechanical hardening and ternary scroll chuck to F-type of KG STOCK GEARS as without Tread hole / without Setscrew.

追加工による最大加工径はハブ径の60-70%を目安としてください。

The tentative maximum bore dimension can be 60-70% from hub diameter for additional machining job.

KG 歯研平歯車の追加工の注意点

Precaution to prevent additional machining for KG-Ground Spur gears.

追加工事の注意

Precaution for additional process.

KG 歯研平歯車はなるべく穴の追加工は避けてください。追加工する事により歯車精度が下がる事があります。キー溝の追加工を行いますと、追加工前に比較してピッチ誤差が微小ながら増大する傾向にあります。なお歯底円とキー溝との距離が近い程その傾向が大きくなります追加工後は歯車精度が（1-2等級）低下します。

We provide the best use of the precision and quality performance of KG Ground Spur Gears to customer. Please install KG Ground Spur Gears without any additional machining in order to prevent deterioration of KG Ground Spur Gears.

Any Additional machining of Keyway to KG Ground Spur Gears will deteriorate the KG Ground Spur Gears due to increasing pitch error compared with before processed. However dimension of Keyway close to root diameter of KG Ground Spur Gears will result in deterioration of 1-2 classes.

穴の追加工の注意

Precaution for additional machining to bore.

必ず生づめスクロールチャックを用いて、チャッキングした商品の穴面から芯だしをしてください。

図のようにチャッキングすれば 外周と側面が研削面となっておりますので、容易に芯が出せます。

外径の小さい（小歯数）歯車は、穴面も焼入れの影響で硬化しており、切削性が悪くなっておりますのでご注意ください。

We recommend that provide scroll chuck without mechanical hardening to obtain locating of center.

The right drawing example shown is highly recommended to obtain the locating of center easily due to dimensions of outer and side grinding processed.

Note that normally a small size of gear (Pinion) is low machinability after heat treatment.

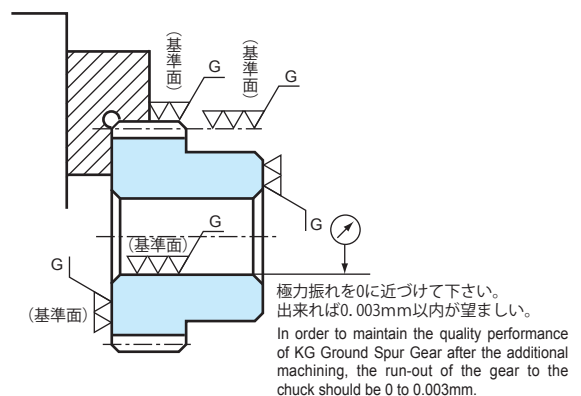

KG ギヤの穴径を追加工するとき

Precaution for additional machining to bore diameter of KG STOCK GEARS.

平歯車、ヘリカルギヤ、ラチェット

Precaution for additional machining to Spur, Helical gears and Ratchet.

歯先外周部をチャッキングする場合は、歯の変形にご注意ください。

Beware deformation of the gears when chucking at outer diameter.

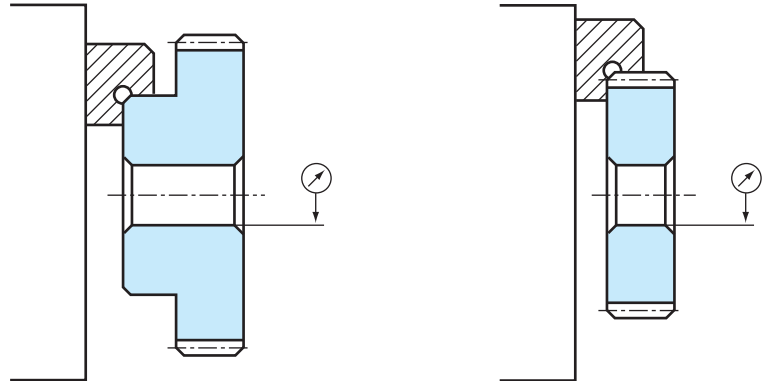

ウォームとウォームホイール

Precaution for additional machining to Worm gear and Worm wheel.

転造仕上げのウォームの場合は、特に歯先外周を出来るだけ深くチャッキングすることを推奨します。歯先外周部をチャッキングする場合は、歯の変形にご注意ください。

Make the best use of the precision and quality performance of KG-Worm gear and Worm wheel to the best of machining ability that deep chucking to the gear is best result. Beware of deformation of the gears.

We provide the best use of the precision and quality performance of KG-Worm and Worm wheel after additional machining. Deep chucking to the gear is highly recommended but beware of deformation.

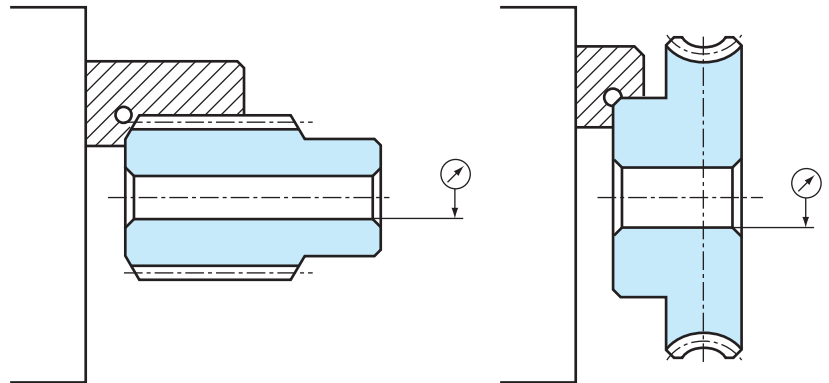

マイタ、ベベルギヤ

Precaution for additional machining to Miter and Bevel gears.

モジュール M2.0 以上の場合は、歯先外周部を軸心と平行に面取りしてありますので、チャッキングすることが出来ます。歯先外周部をチャッキングする場合は、歯の変形にご注意ください。

Module 2.0 and above has been machined flat as respected shaft center to parallel.

Tip diameter can be chucked. Beware deformation of the gears.

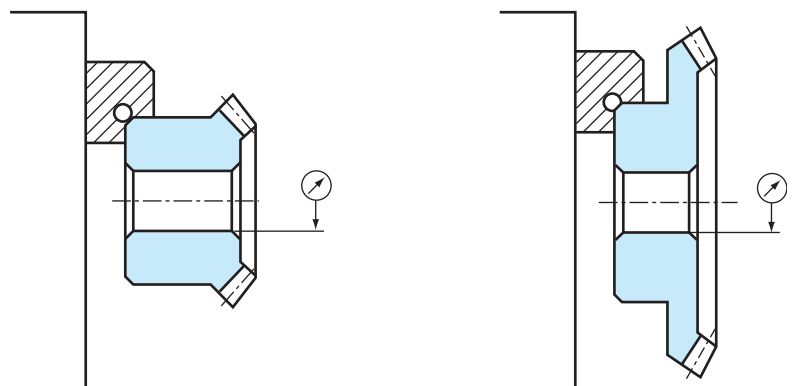

追加工時のチャッキングの際、刻印がある場所をさけてチャッキングして下さい。

Caution! do not chuck at area of KG-mark when performing additional machining.

高周波焼入れをしてある歯車を追加工される場合、歯部に近い部分は熱処理の影響で硬化しておりますのでご注意ください。また、外径の小さい(小歯数)歯車は、穴面も焼入れの影響で硬化しており、切削性が悪くなりますのでご注意ください。Due to induction hardening, take note that surface near to the gear tooth area may be low machinability due to the heat treatment processed.

Also, the bore diameter of small size gears (Pinion) may not be easily machined.

ノーバックラッシギヤをお使いいただくにあたって

Summarize Information of Anti Backlash Spur gears.

平歯車のバックラッシを小さくしたい！
In compliance with the wish to obtain small backlash

項目 Description	歯車の性能 Gear performance				材質、表面処理 Material and Surface treatment		
	回転精度 (歯車精度) Gear finishing	バックラッシ の調整 Adjustment of backlash	伝達動力 Transmissibility	タイプ Type	材質 Material	表面処理 Surface treatment	耐食性 Anticorrosion
商品記号 Catalogue number							
NSG シリーズ NSG series (ノーバックラッシギヤ) Anti backlash gear	◎ 歯面研削仕上げ Ground teeth	不要 Not necessary	○	円弧バネ式 Circular Arc Spring	SCM435	-	-
				引張バネ式 Coiled Spring			
	○	不要 Not necessary	○	円弧バネ式 Circular Arc Spring	アルミニウム Aluminum	アルマイト Anodized	-
NS シリーズ NS series (ノーバックラッシギヤ) Anti backlash gear	○	不要 Not necessary	○	引張バネ式 Coiled Spring	S45C	軟窒化処理 Isonite	△
NSU シリーズ NSU series (ノーバックラッシギヤ) Anti backlash gear	○	不要 Not necessary	○	引張バネ式 Coiled Spring	SUS304	テフロン系 表面処理 Applied treatment of Teflon	◎
ASG シリーズ ASG series (コントロール バックラッシギヤ)	◎ 歯面研削仕上げ Ground teeth	要 Necessary	◎	ボルト固定式 Fixed Bolt	SCM435	-	-

詳しくは本カタログの歯車の寸法およびをご覧ください
Please refer more details inside KG catalogue

HY-BOX、B-BOX、B-SET をお使いいただくにあたって

Summarize Information of HY-BOX, B-BOX and B-SET.

ベベルギヤユニットを使用したい！
For cost saving and reduce working time.

項目 Description	静粛性 Gear performance	バックラッシ Backlash	伝達動力 Transmissibility	タイプ Type	軸受 Bearing	潤滑 Lubrication	記事 Function
商品記号 Catalogue number							
HY シリーズ HY series (HY-BOX)	◎ 高精度ギヤ使用 Precision gear used	◎ 20' 以下 Below 20'	◎	密閉型 Sealed type	ボールベアリング Ball bearing	グリス封入 Grease sealed	高減速比 High gear ratio 高効率 High Efficiency 高精度 High precision
BSH シリーズ BSH series (B-BOX)	◎ 高精度ギヤ使用 Precision gear used	◎ 15' 以下 Below 15'	◎	密閉型 Sealed type	ボールベアリング Ball bearing	グリス封入 Grease sealed	高強度 High performance 高精度 High precision コンパクト Compact
BS シリーズ BS series (B-BOX)	◎ ラッピングギヤ使用 Lapping gear used	◎ 20' 以下 Below 20'	◎	密閉型 Sealed type	ボールベアリング Ball bearing	グリス封入 Grease sealed	高精度 High precision コンパクト Compact
BE シリーズ BE series (B-SET)	○	○	○	開放型 Opened type	無給油すべり軸受け Oil Free bearing	定期的に歯面への グリス塗布が必要 Necessary to apply grease to teeth regularly.	ローコスト Competitive price
WS シリーズ WS series (W-BOX)	◎ 精密転造ギヤ使用 Precision Cold Rolled processed Worm used	◎ 25' 以下	◎	密閉型 Sealed type	ボールベアリング Ball bearing	オイル潤滑	高速仕様 High Speed 高減速比 High gear ratio コンパクト Compact

詳しくは本カタログの歯車の寸法およびをご覧ください
Please refer more details inside KG catalogue

KG STOCK GEARS のバックラッシ

Amount of backlash for KG STOCK GEARS.

バックラッシとは、歯車をかみ合わせたときの“歯面間の遊び”または、“すき間” のことです。

当社の歯車を所定の中心距離で組み合わせたときのバックラッシを以下に示します。

What is the Backlash? There are PLY or CLEARANCE when matching the gears. Please refer to the pair of backlash amount for KG STOCK GEARS when setting appointed center distance as follows.

平歯車のバックラッシ（同材質での一対のかみ合い）

Backlash amount of Spur gear (the same material and one pair of gear engagement)

モジュール (m) Module	材質 Material	バックラッシ (mm) Backlash
モジュール 0.9 以下の商品は 0.02 ~ 0.06 Range from below M=0.9 is 0.02-0.06		
M=0.9 を超え M=3.0 以下 Range from M=0.9 to M=3.0	D, SU, BS	$0.06 \times m \sim 0.12 \times m$
	S	$0.04 \times m \sim 0.10 \times m$
M=3 を超え M= 5 以下 Range from M= 3 to M=5	SCM	$0.04 \times m \sim 0.08 \times m$
	S	$0.06 \times m \sim 0.12 \times m$

D: ポリアセタール、SU: SUS304、S: S45C、SCM: SCM435、440（歯研品）、BS: 黄銅
D: Acetal, SU: SUS304, S: S45C, SCM: SCM435,440, BS: Brass

ウオームギヤのバックラッシ（一対のかみあい）

Backlash of Worm gear pair (One pair of gear engagement)

かみあい中心距離 (mm) Center distance	バックラッシ (mm) Backlash
モジュール 0.8 以下の商品は 0.06 ~ 0.15 Range from below M=0.8 is 0.06-0.15	
50 以下 Below 50	0.08 ~ 0.20
50 を超え 150 以下 Range from 50 to 150.	0.15 ~ 0.30
150 を超え 300 以下 Range from 150 to 300.	0.30 ~ 0.50

かさ歯車のバックラッシ（一対のかみあい）

Backlash of Bevel gear (one pair of gear engagement)

モジュール (m) Module	バックラッシ (mm) Backlash	
	SCM、S、SU、BS SCM435, S45C, SUS304, Brass	D Acetal
M=0.9 以下 Range below M=0.9	0.02 ~ 0.08	0.03 ~ 0.10
0.9 を超え 2 以下 Range from M=0.9 to M=2.0	0.05 ~ 0.12	0.05 ~ 0.16
2 を超え 4 以下 Range from M=2 to M=4	0.06 ~ 0.15	—
4 を超え 6 以下 Range from M=4 to M=6	0.08 ~ 0.20	—
6 を超え 7 以下 Range from M=6 to M=7	0.10 ~ 0.22	—

KG ギヤ・インフォメーション

KG Gear - Information

KG 歯車教育キット

KG 歯車教育キット

KG-Gear's Educational Kit.



教育現場に最適!
**Suitable instrument tool
 for education practice!**

歯車の基礎（仕組み）が理解できます。
 歯車の機能をさわって確認できます。

Can be understood the basic knowledge of gears easily
 Can be verified with touched the function of gears easily

サイズ Size 335 × 272 × 130 (W×D×H)
 重量 Weight 6.7kg



GEAR SYSTEMS

HY-BOX

B-BOX®

W-BOX

B-SET

商標登録済
Registered of TRADE MARK

商品記号の読み方 Reference of Catalogue Number

WS 75 R - 040
HY 70 R - 005
BS 45 L - 001
BS 80 T - 002
BSH 140 L - 001
BE 40 L - 001
BE 70 L - 002 B

種類 Kind of Product	軸端面距離 Distance from back face to shaft end	形状 Direction of Shaft Type of Body	レシオ Gear Ratio	形状 Identification of Shaft diameter
HY : Hypoid Gearbox (ハイポイドギヤボックス) BS : Bevel Gearbox (ベベルギヤボックス) BSH : Bevel Gearbox (ベベルギヤボックス) BE : Bevel Gear Set (ベベルギヤセット) WS : Worm Gearbox (ウォームギヤボックス)	単位 : mm Dimension : millimeter	R : ギヤ軸右 R : Pinion shaft is shown on the front, and gear shaft is shown on the right side. L : L形 L : Type L T : T形 T : Type T	001 : (レシオ 1 : 1) 001 : (ratio 1 : 1) 002 : (レシオ 2 : 1) 002 : (ratio 2 : 1) 005 : (レシオ 5 : 1) 005 : (ratio 5 : 1) 010 : (レシオ 10 : 1) 010 : (ratio 10 : 1)	A : 細軸タイプ A : Shaft diameter is small. B : 太軸タイプ B : Shaft diameter is large.

Gear Systems の特徴

The Feature of Gear Systems

- 1) コンパクトでシンプルなデザインを採用しております。
 - 2) ギヤが完全バックされているため、防塵対策になります。
 - 3) 高精度の KG ギヤを内蔵しており、バックラッシュは組み立て時に BS タイプで 15 ~ 20' 以下、BSH タイプで 10 ~ 15' 以下、HY-BOX は 20' 以下、W-BOX は 25' 以下に設定しております。(レシオが 2 以上の場合はギヤ軸側のバックラッシュとなります。)
 - 4) 取り付け用のねじ穴加工を施してありますので、簡単に取り付け可能です。
 - 5) 潤滑はグリース封入です (BS タイプにはオイルシールを施していません) (W-BOX はオイル滑滑)
- 1) Compact and Simple design.
 - 2) Completely sealed casing provide safety and dust free during operation.
 - 3) With built in accuracy of KG-Bevel Gear, when assembled gearbox, backlash of assembly provided 15' to 20' and less for BS type. 10' to 15' and less for BSH type, and 20' for HY-BOX, 25' for W-BOX. (The above values shown a gear axes side backlash, if gearbox with ratio for 2 or more.)
 - 4) Come with pre tap holes for easy mounting.
 - 5) Lubricated with high quality grease before sealed.(The oilseal of BS type is not provided.) (W-BOX is oil lubrication.)

取り付け上の注意点と基準面

Precaution of Mounting base and Installation.

- 1) B-BOX、HY-BOX、W-BOX はボディーの全ての面が基準面になっております。B-SET の基準面は両側面になっております。
 - 2) Gear Systems を相手取り付け面に固定する場合、歯車軸と相手軸が平行で且つ軸芯が一致するように正確に取り付けてご使用下さい。相手軸との同軸度は $\phi 0.05\text{mm}$ 以下を推奨します。
 - 3) 歯車軸と相手軸との連結には、出来るだけフレキシブルな市販のカップリングをご使用下さい。
 - 4) 取り付けベースは、振動しない様に剛性を高くして下さい。
 - 5) 周辺温度は、B-BOX で $-20^{\circ}\text{C} \sim 50^{\circ}\text{C}$ 、HY-BOX、W-BOX で $-10^{\circ}\text{C} \sim 40^{\circ}\text{C}$ の通気性の良い所でご使用下さい。
- 1) All of surface on the body for B-BOX and HY-BOX, W-BOX can be used as mounting base. The mounting base of B-SET is both sides of body.
 - 2) When assembly of Gear Systems to the match base, provide accurate parallelism and shaft center between gear shaft and match shaft. Accuracy of alignment 0.05 millimeters and less recommended.
 - 3) When connecting B-BOX to match shaft with the coupling. The flexible coupling will reduce misalignment and easy installation.
 - 4) Prevent vibration and provide stable mounting base.
 - 5) The surrounding of well ventilated area, temperature of -20°C to 50°C for B-BOX, and -10°C to 40°C for HY-BOX, W-BOX are recommended.

使用上の注意

Precaution of the Usage

- 1) 運転中は本体に手を絶対に触れないで下さい。軸部に加工されているキー溝のエッジ部や、露出している軸用止め輪に異物の巻き込みなどにも注意して下さい。
 - 2) 運転中に異常音が出る場合や本体温度が異常に上昇するなど異常を感じた場合は、直ちに運転を中止し異常原因を改善するまで再運転しないで下さい。
 - 3) B-SET が運転可能な状態になっているときは、必ず付属の簡易プラスチックカバーを本体に確実にセットして下さい。運転中に振動、その他の原因で本体より外れる可能性がある場合はねじ等を使用して確実に固定して下さい。付属のプラスチックカバーが、破損又は経年変化により劣化した場合は、新しいものと交換して下さい。(別売りしております。)
 - 4) B-BOX、HY-BOX、W-BOX はなじみ運転として通常負荷の 1/2 ~ 1/3 を目安に約 6 時間以上行うことを推奨いたします。
 - 5) 増速にてお使いになる場合は、等速または減速に比較して騒音および温度上昇が高くなる傾向があります。また、伝達動力は小さくなります。
- 1) Do not touch the gearbox, shaft and key during operation.
 - 2) Stop operation and check fault if there is any problems such as unusual noise and high temperature occur from the gearbox. Do not start the machine until the fault has been clarified.
 - 3) Make sure that body of B-SET properly covered by plastic, we recommend mounting holes to be tightened with screws on the plastic cover to prevent vibrations and other causes to occur during operation. Plastic cover is available for purchase as spare parts for maintenance used when time to be replaced and the aged deterioration.
 - 4) To warm up B-BOX and HY BOX, W-BOX we recommend to apply 1/2 to 1/3 of normal loads for over six hours.
 - 5) Power to output shaft, noise level and temperature will increase when gear is rotating at high speed and the power transfer will also be decreased. The opposite is true at low speed.

追加工上の注意

Precaution of Additional Works.

- 1) 軸受部に切り屑などが入らないように防塵処置をしてから加工して下さい。
 - 2) 軸部に追加工をする場合は、軸や他の部分に変形しない様に注意して下さい。
オイルシール部は傷をつけないようにマスキングを施して下さい。
ボディーに追加工をする場合は、弊社までご相談下さい。
- 1) Before machining, ensure that the bearing portion is covered, so that waste objects will not be inserted into.
 - 2) Beware of shaft deformation and other parts when additional machining works on the body and tap hole. To avoid damage of the gearbox, please contact us before machining job.

動力伝達について

Reading the Power Transfer.

- 1) 許容負荷は伝達能力表に記載されている回転数 [min⁻¹] とトルク [N・cm] 以下で使用下さい。
 - 2) B-BOX(BS)、B-SET、HY-BOX、W-BOX のピニオン軸にオーバーハング、スラスト荷重が作用する様な使用方法は行なわないで下さい。
各軸にオーバーハング荷重が作用する場合は本機とは別に荷重を受ける機構を設けて下さい。
B-BOX(BSH)、HY-BOX、W-BOX のギヤ軸へのオーバーハング荷重は、オーバーハング荷重許容値及び荷重位置を参照して下さい。
- 1) For best performance and lifespan of the B-BOX (BS and BSH), B-SET, HY-BOX and W-BOX, please refer to the Allowable transfer capability torque table. Regarding the range of Input torque (N.cm) and Input revolution/min for B-BOX (BS and BSH), B-SET, HY-BOX and W-BOX should not exceed the figures indicated inside the Allowable transfer capability torque table.
 - 2) Avoid overhang load and thrust load to axes of B-BOX(BS), B-SET, HY-BOX and W-BOX following installation method. For allowable amount of overhang load and location of load on the gear axes, please refer to the catalogue. In case there are overhang and thrust load, it is necessary to design an extra preventable equipment.

入力と速比及びギヤレイアウト

Gear layout (Input, Output and Ratio)

レシオ Ratio	L形 Type L	T形 Type T
<p>2 : 1</p> <p>X軸を入力した場合 X shaft as input shaft</p> <p>回転方向は限定されません 正逆可です。 Reversible Rotation</p>	<p>X軸 (ピニオン) X Shaft (Pinion)</p> <p>Y軸 (ギヤ) Y Shaft (Gear)</p>	<p>X軸 (ピニオン) X Shaft (Pinion)</p> <p>Y軸 (ギヤ) Y Shaft (Gear)</p>
<p>1 : 1</p> <p>回転方向は限定されません 正逆可です。 Reversible Rotation</p>	<p>X軸 X Shaft (Pinion)</p> <p>Y軸 Y Shaft</p>	<p>X軸 X Shaft</p> <p>Y軸 Y Shaft</p>

HY-BOX ハイボックス

HY-BOXES

目次
CONTENTS

インフォメーション
INFORMATION

ギヤボックス
GEAR BOXES

ノーバッキング
ANTI BACKLASH SPUR GEAR

歯研平歯車
GROUND SPUR GEARS

平歯車
SPUR GEARS

内歯車
INTERNAL GEARS

歯研ラック
GROUND RACKS

ラック
RACKS

ヘリカル・スクリューギヤ
HELICAL GEARS AND SCREW GEARS

ウォーム・ウォームホイール
WORMS AND WORM WHEELS

かさ歯車
BEVEL GEARS

スプロケット
SPROCKETS

技術資料
REFERENCE DATA



ボディー (A5052P、A5056) アルミニウム 黒色アルマイト処理 シャフト (P : SCM435、G : S45C)
Material : Body-Aluminium (ISO AlMg2.5, AlMg5) with Anodize treated Shaft (P=Pinion, G=Gear)

単位 : mm
Dimensions : mm

商品記号 Catalogue Number	レシオ Gear Ratio	A	B	C	D	E	F	G	軸径 Shaft		J	K	L	M
									$\phi H(h7)$	$\phi I(h7)$				
HY 70R - 005	5	70	58	45	55	40	15	18	$\phi 6$	$\phi 8$	20	17.5	36	22.5
HY 90R - 010	10	90	68	60	75	50	15	18	$\phi 6$	$\phi 8$	25	20	47	30
HY 95R - 005	5	95	75	60	75	50	20	25	$\phi 8$	$\phi 12$	25	20	49	30
HY 120R - 010	10	120	80	80	100	55	20	25	$\phi 8$	$\phi 12$	27.5	25	62	40
HY 125R - 005	5	125	85	80	100	55	25	30	$\phi 12$	$\phi 15$	27.5	30	65	40
HY 150R - 010	10	150	90	95	125	60	25	30	$\phi 12$	$\phi 15$	30	32.5	77	47.5

許容伝達トルク表

Allowable transfer capability torque table

入力回転速度 min ⁻¹ (rpm) Input Revolution/min ギヤサイズ Gear 商品記号 Catalogue Numbers	入力トルク (N・cm) Input Torque (N・cm)								
	100	250	500	800	1,000	1,500	2,000	2,500	
HY 70R - 005	m 0.75 × 8/40	76.0	71.8	66.0	59.0	53.9	44.2	36.6	28.4
HY 90R - 010	m 0.71 × 7/70	75.8	70.8	63.8	56.0	50.7	41.3	34.3	27.3
HY 95R - 005	m 1.1 × 8/40	247.4	232.1	211.8	187.7	170.3	137.7	112.6	86.0
HY 120R - 010	m 1.0 × 7/70	186.3	172.7	155.7	136.6	123.5	100.0	82.7	65.0
HY 125R - 005	m 1.5 × 8/40	414.8	400.6	377.6	345.4	319.8	266.9	223.0	173.9
HY 150R - 010	m 1.45 × 6/60	357.2	336.1	307.3	272.1	246.5	197.5	159.2	118.1

HY-BOX ハイボックス

HY-BOXES

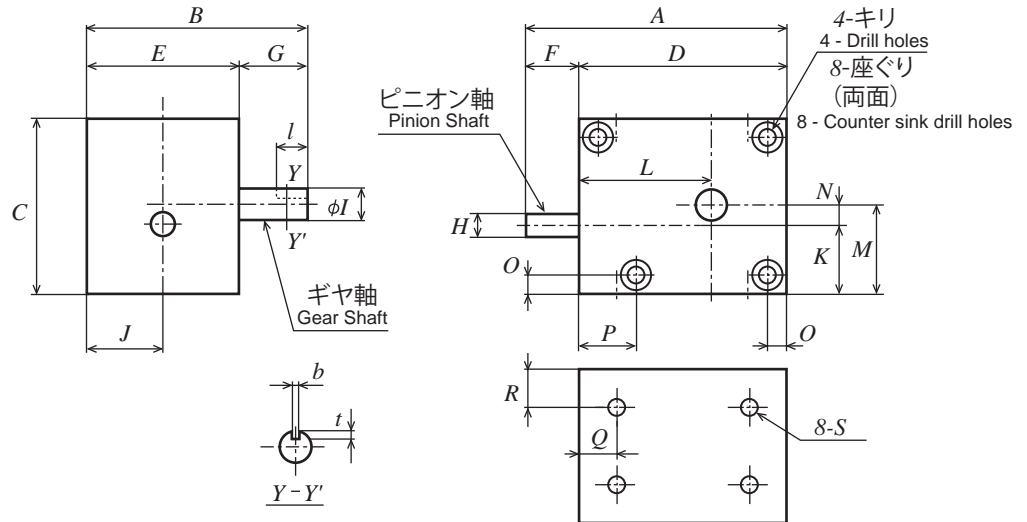

ボディ (A5052P、A5056) アルミニウム 黒色アルマイト処理 シャフト (P : SCM435、G : S45C)
 Material : Body-Aluminium (ISO AlMg2.5, AlMg5) with Anodize treated Shaft (P=Pinion, G=Gear)

単位 : mm
 Dimensions : mm

オフセット offset	N	O	P	Q	R	取付けねじ Set Screw		Counter Sinks & Drill Holes			キーみぞ Key Way			バック ラッシ Backlash (')	オーバーハング 荷重許容 Maximum overhang load (N)	重量 Weight W(kg)	商品記号 Catalogue Number
						8-S	深さ Depth	キリ穴 Drill Hole Diameter	サグリ径 Counter Sink Diameter	サグリ深さ Counter Sink Depth	b	t	l				
5	5	14	10	10	10	8-M3	5	φ3.2	φ6.5	3.2	-	-	-	20	19	0.3	HY 70R - 005
10	7	26	12	12	12	8-M4	6	φ4.2	φ8.0	4.3	-	-	-	20	19	0.6	HY 90R - 010
10	7	28	12	12	12	8-M4	6	φ4.2	φ8.0	4.3	-	-	-	20	39	0.7	HY 95R - 005
15	10	27	15	12	12	8-M5	8	φ5.2	φ9.5	5.3	-	-	-	20	39	1.3	HY 120R - 010
10	10	27	18	12	12	8-M5	8	φ5.2	φ9.5	5.3	5	3	20	20	54	1.4	HY 125R - 005
15	10	27	20	12	12	8-M5	8	φ5.2	φ9.5	5.3	5	3	20	20	54	2.2	HY 150R - 010

バックラッシはギヤ軸側のバックラッシとなります
 Backlash : Measured at gear shaft



図 オーバーハング荷重位置および軸の回転方向
 Load position of overhang and direction of the rotation.

目次
CONTENTS

インフォメーション
INFORMATION

ギヤボックス
GEAR BOXES

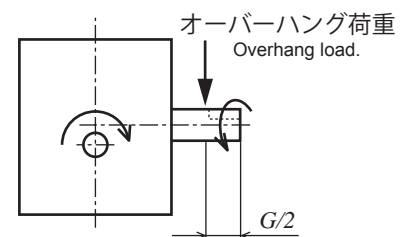
ノーバッキング
ANTI BACKLASH SPUR GEARS

歯
GROUND SPUR GEARS

平歯
SPUR GEARS

内歯
INTERNAL GEARS

歯
GROUND RACKS

ラッシ
RACKS

（）
HELICAL GEARS AND SCREW GEARS

マ
WORMS AND WORM WHEELS

か
BEVEL GEARS

ス
SPROCKETS

技
REFERENCE DATA

B-BOX[®] ビーボックス

B-BOXES (BS)



ボディー (A5056、A6061、A6063) アルミニウム 黒色アルマイト処理 シャフト (SUS303)
Material : Body-Aluminium (ISO AlMg5, AlMg1SiCu, AlMg0.7Si) with Anodize treated Shaft-Stainless steel

単位 : mm
 Dimensions : mm

商品記号 Catalogue Number	形 Type	レシオ Gear Ratio	Z	Y	□ C	A	B	軸径 Shaft φD(h7)	E
BS 35 L - 001	L	1	-	-	14	35	27	φ 3	8
BS 45 L - 001	L	1	-	-	18	45	33	φ 4	12
BS 65 L - 001	L	1	-	-	25	65	50	φ 6	15
BS 80 L - 001	L	1	-	-	30	80	60	φ 8	20
BS 90 L - 001	L	1	-	-	35	90	70	φ10	20
BS 105 L - 001	L	1	-	-	40	105	80	φ12	25
BS 65 L - 002	L	2	-	-	25	65	50	φ 6	15
BS 80 L - 002	L	2	-	-	30	80	60	φ 8	20
BS 90 L - 002	L	2	-	-	35	90	70	φ10	20
BS 105 L - 002	L	2	-	-	40	105	80	φ12	25
BS 45 T - 001	T	1	72	48	18	45	33	φ 4	12
BS 65 T - 001	T	1	105	75	25	65	50	φ 6	15
BS 80 T - 001	T	1	130	90	30	80	60	φ 8	20
BS 90 T - 001	T	1	145	105	35	90	70	φ10	20
BS 105 T - 001	T	1	170	120	40	105	80	φ12	25
BS 65 T - 002	T	2	105	75	25	65	50	φ 6	15
BS 80 T - 002	T	2	130	90	30	80	60	φ 8	20
BS 90 T - 002	T	2	145	105	35	90	70	φ10	20
BS 105 T - 002	T	2	170	120	40	105	80	φ12	25

D 軸の位相は一致しておりません。
 Directions of the D-cut shaft face are not fixed.

特殊仕様および追加工（使用環境、オイルリーク対策、軸径追加工等取付方法）についてはご相談下さい。
 Please do not hesitate to contact us for special method of installation, checking on the usage environment and work out of oil leaks.



GOOD DESIGN AWARD 2010

**LONG LIFE
 DESIGN AWARD**

B-BOX[®] ビーボックス

B-BOXES (BS)

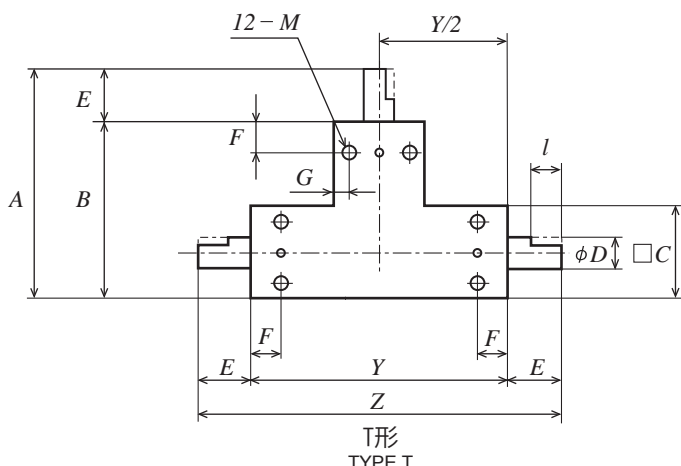
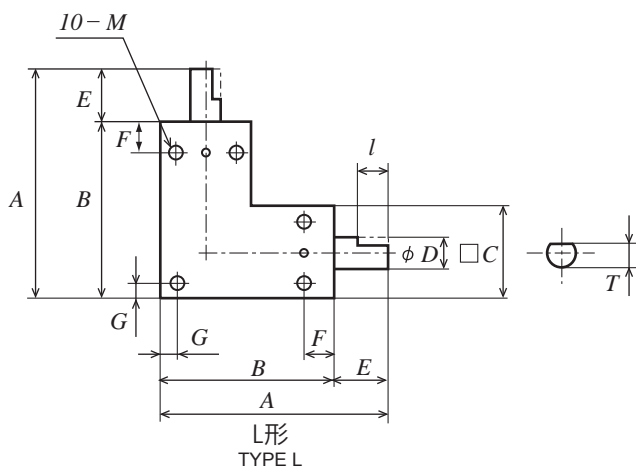

ボディ (A5056、A6061、A6063) アルミニウム 黒色アルマイト処理 シャフト (SUS303)

Material : Body-Aluminium (ISO AlMg5, AlMg1SiCu, AlMg0.7Si) with Anodize treated Shaft-Stainless steel

単位 : mm
Dimensions : mm

F	G	軸端形状 Shape of Shaft end			取付けねじ Set Screw		バック ラッシュ Backlash (')	重量 Weight W(g)	商品記号 Catalogue Number
		ϕD	T	l	M	深さ Depth			
4	2	D	2.7	5	10-M2	4	20	27	BS 35 L - 001
5	3	D	3.3	8	10-M3	4	15	55	BS 45 L - 001
12	3.5	ϕ	-	-	10-M4	6	15	175	BS 65 L - 001
15	5	ϕ	-	-	10-M5	6	15	290	BS 80 L - 001
15	5	ϕ	-	-	10-M5	7	15	496	BS 90 L - 001
20	5	ϕ	-	-	10-M6	7	15	725	BS 105 L - 001
12	3.5	ϕ	-	-	10-M4	6	15	175	BS 65 L - 002
15	5	ϕ	-	-	10-M5	6	15	290	BS 80 L - 002
15	5	ϕ	-	-	10-M5	7	15	496	BS 90 L - 002
20	5	ϕ	-	-	10-M6	7	15	725	BS 105 L - 002
5	3	D	3.3	8	12-M3	4	15	75	BS 45 T - 001
12	3.5	ϕ	-	-	12-M4	6	15	246	BS 65 T - 001
15	5	ϕ	-	-	12-M5	6	15	410	BS 80 T - 001
15	5	ϕ	-	-	12-M5	7	15	679	BS 90 T - 001
20	5	ϕ	-	-	12-M6	7	15	991	BS 105 T - 001
12	3.5	ϕ	-	-	12-M4	6	15	246	BS 65 T - 002
15	5	ϕ	-	-	12-M5	6	15	410	BS 80 T - 002
15	5	ϕ	-	-	12-M5	7	15	679	BS 90 T - 002
20	5	ϕ	-	-	12-M6	7	15	991	BS 105 T - 002

許容伝達トルク表 Allowable transfer capability torque table

入力回転速度 min ⁻¹ (rpm) Input Revolution/min ギヤサイズ Gear 商品記号 Catalogue Numbers	入力トルク (N・cm) Input Torque (N・cm)									
	50	100	250	500	800	1,000	1,500	2,000		
BS 35 L - 001		m0.4 × 20	7.1	7.0	6.8	6.5	6.2	6.0	5.5	5.3
BS 45 L - 001	BS 45 T - 001	m0.5 × 20	18.7	18.6	18.1	17.3	16.5	16.0	15.0	14.0
BS 65 L - 001	BS 65 T - 001	m0.8 × 20	73.7	72.6	69.8	65.6	61.0	58.4	52.6	47.9
BS 80 L - 001	BS 80 T - 001	m1.0 × 20	137.9	135.6	129.1	119.5	109.7	104.0	92.0	82.6
BS 90 L - 001	BS 90 T - 001	m1.25 × 20	271.8	266.1	250.4	228.0	205.8	193.3	167.8	148.2
BS 105 L - 001	BS 105 T - 001	m1.5 × 20	442.6	431.6	401.6	360.0	320.1	298.1	254.3	221.9
BS 65 L - 002	BS 65 T - 002	m0.6 × 14/28	20.2	20.1	19.7	19.0	18.3	17.8	16.7	15.7
BS 80 L - 002	BS 80 T - 002	m0.8 × 13/26	39.8	39.5	38.4	36.8	35.1	34.0	31.5	29.5
BS 90 L - 002	BS 90 T - 002	m1.0 × 13/26	77.6	76.7	74.3	70.5	66.4	64.0	58.6	54.0
BS 105 L - 002	BS 105 T - 002	m1.25 × 13/26	141.5	139.6	134.0	125.7	116.9	111.7	100.7	91.5

レシオが2の場合はピニオン軸の入力回転数および入力トルクを示しています。 The gear ratio 1 : 2, table shown input revolution and torque on the pinion shaft.

目次 CONTENTS
インフォメーション INFORMATION
ギヤボックス GEAR BOXES
ノーバッキングバックラッシュギヤボックス ANTI BACKLASH SPUR GEARS
歯車 SPUR GEARS
歯車 GROUND SPUR GEARS
歯車 INTERNAL GEARS
歯車 GROUND RACKS
歯車 RACKS
歯車 HELICAL GEARS AND SCREW GEARS
歯車 WORMS AND WORM WHEELS
歯車 BEVEL GEARS
歯車 SPROCKETS
技術データ REFERENCE DATA

B-BOX® ビーボックス

B-BOXES (BSB)



ボディ (A6063、A6061) アルミニウム 黒色アルマイト処理 **シャフト (SUS303)**
Material : Body-Aluminium (ISO AIMg0.7Si, AIMg1SiCu) with Anodize treated **Shaft-Stainless steel**

単位 : mm
 Dimensions : mm

商品記号 Catalogue Number	形 Type	レシオ Gear Ratio	□ C	A	B	軸径 Shaft φD(h7)	穴径 Bore		E	I
							φH(H7)	有効深さ Depth		
BSB 65L - 001A	LB	1	25	65	50	φ 6	φ 5	15	15	5
BSB 65L - 001B	LB	1	25	65	50	φ 6	φ 6	15	15	5
BSB 80L - 001A	LB	1	30	80	60	φ 8	φ 6	19	20	5
BSB 80L - 001B	LB	1	30	80	60	φ 8	φ 8	19	20	5
BSB 90L - 001A	LB	1	35	90	70	φ10	φ 8	19	20	6
BSB 90L - 001B	LB	1	35	90	70	φ10	φ10	19	20	6
BSB 105L - 001A	LB	1	40	105	80	φ12	φ10	23	25	6
BSB 105L - 001B	LB	1	40	105	80	φ12	φ12	23	25	6

LB形と連結する軸が丸軸の場合は、平座面を2箇所（120°配）設けて下さい。

軸が段付の場合は、応力集中を避けるため大きなRを設けて下さい。

When mating round axis connects with LB type, please fabricate mating round axis with 2 flat surfaces at 120° apart.

When use axis with step, make large R to corner of axis to avoid stress concentration.

特殊仕様および追加工（使用環境、オイルリーク対策、軸径追加工等取付方法）についてはご相談下さい。

Please do not hesitate to contact us for special method of installation, checking on the usage environment and work out of oil leaks.



B-BOX とモーターの取付例
 Example of installing B-BOX and motor.

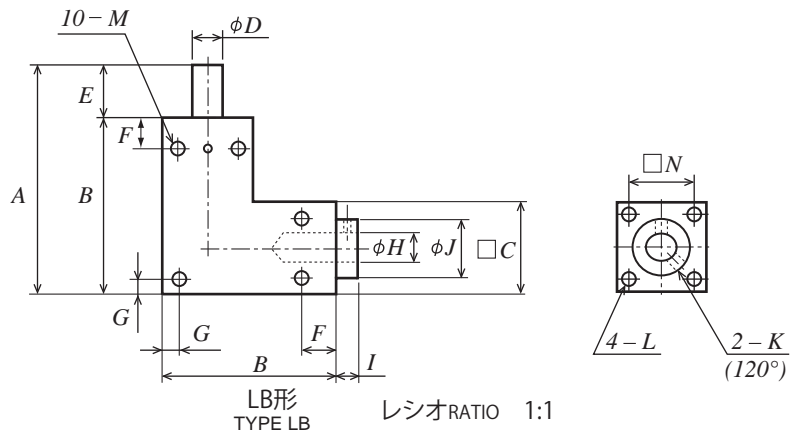

ボディー (A6063、A6061) アルミニウム 黑色アルマイト処理 シャフト (SUS303)
Material : Body-Aluminium (ISO AlMg0.7Si, AlMg1SiCu) with Anodize treated Shaft-Stainless steel

単位 : mm
 Dimensions : mm

φJ	2-K(120°)	F	G	取付けねじ Set Screw		取付けねじ Set Screw			バックラッシュ Backlash (')	重量 Weight W(g)	商品記号 Catalogue Number
				10-M	深さ Depth	4-L	□ N	深さ Depth			
16	2-M3	12	3.5	10-M4	6	4-M3	19	6	15	169	BSB 65L - 001A
16	2-M3	12	3.5	10-M4	6	4-M3	19	6	15	167	BSB 65L - 001B
19	2-M3	15	5	10-M5	6	4-M3	23	8	15	293	BSB 80L - 001A
19	2-M3	15	5	10-M5	6	4-M3	23	8	15	289	BSB 80L - 001B
21	2-M4	15	5	10-M5	7	4-M4	25	8	15	465	BSB 90L - 001A
21	2-M4	15	5	10-M5	7	4-M4	25	8	15	460	BSB 90L - 001B
26	2-M4	20	5	10-M6	7	4-M4	30	10	15	722	BSB 105L - 001A
26	2-M4	20	5	10-M6	7	4-M4	30	10	15	713	BSB 105L - 001B

許容伝達トルク表 Allowable transfer capability torque table

入力回転速度 min ⁻¹ (rpm) Input Revolution/min ギヤサイズ Gear 商品記号 Catalogue Numbers	入力トルク (N・cm) Input Torque (N・cm)								
	50	100	250	500	800	1,000	1,500	2,000	
BSB 65L - 001A/B	m0.8 × 20	73.7	72.6	69.8	65.6	61.0	58.4	52.6	47.9
BSB 80L - 001A/B	m1.0 × 20	137.9	135.6	129.1	119.5	109.7	104.0	92.0	82.6
BSB 90L - 001A/B	m1.25 × 20	271.8	266.1	250.4	228.0	205.8	193.3	167.8	148.2
BSB 105L - 001A/B	m1.5 × 20	442.6	431.6	401.6	360.0	320.1	298.1	254.3	221.9

レシオが2の場合はピニオン軸の入力回転数および入力トルクを示しています。 The gear ratio 1 : 2, table shown input revolution and torque on the pinion shaft.

B-BOX® ビーボックス

B-BOXES (BSH)



寸法表

ボディー (A6063、A6061) (FC200、FC250)

Material : Body-Aluminium (ISO AlMg0.7Si, AlMg1SiCu) and Grey Iron Castings (JIS G5501 FC200, FC250)

シャフト (SUS303) (S45C)

Shaft-Stainless and Carbon steels

単位 : mm

Dimensions : mm

商品記号 Catalogue Number	素材 Material			形 Type	レシオ Gear Ratio	Z	Y	□ C	A	B	軸径 Shaft	
	ボディ Body	ボディの表面処理 Surface treatment of body	シャフト Shaft								$\phi D(h7)$	E
BSH 70L - 001	AL	アルマイト	SUS303	L	1	-	-	27	70	54	$\phi 6$	16
BSH 85L - 001	AL	アルマイト	SUS303	L	1	-	-	32	85	64	$\phi 8$	21
BSH 95L - 001	AL	アルマイト	SUS303	L	1	-	-	36	95	72	$\phi 10$	23
BSH 115L - 001	FC	四三酸化鉄皮膜	S45C	L	1	-	-	45	115	90	$\phi 12$	25
BSH 120L - 001	FC	四三酸化鉄皮膜	S45C	L	1	-	-	45	120	90	$\phi 15$	30
BSH 140L - 001	FC	四三酸化鉄皮膜	S45C	L	1	-	-	55	140	110	$\phi 15$	30
BSH 145L - 001	FC	四三酸化鉄皮膜	S45C	L	1	-	-	55	145	110	$\phi 20$	35
BSH 165L - 001	FC	四三酸化鉄皮膜	S45C	L	1	-	-	65	165	130	$\phi 20$	35
BSH 170L - 001	FC	四三酸化鉄皮膜	S45C	L	1	-	-	65	170	130	$\phi 25$	40
BSH 70T - 001	AL	アルマイト	SUS303	T	1	113	81	27	70	54	$\phi 6$	16
BSH 85T - 001	AL	アルマイト	SUS303	T	1	138	96	32	85	64	$\phi 8$	21
BSH 95T - 001	AL	アルマイト	SUS303	T	1	154	108	36	95	72	$\phi 10$	23
BSH 115T - 001	FC	四三酸化鉄皮膜	S45C	T	1	143	93	45	115	90	$\phi 12$	25
BSH 120T - 001	FC	四三酸化鉄皮膜	S45C	T	1	153	93	45	120	90	$\phi 15$	30
BSH 140T - 001	FC	四三酸化鉄皮膜	S45C	T	1	175	115	55	140	110	$\phi 15$	30
BSH 145T - 001	FC	四三酸化鉄皮膜	S45C	T	1	185	115	55	145	110	$\phi 20$	35

キーみぞの位相は一致しておりません。

Directions of the Key Way position are not fix.

ボディ素材 AL : A6063 , A6061 with Anodize treated
Surface treatments FC : FC200 , FC250 with Black oxide coating
and material of body

許容伝達トルク表

Allowable transfer capability torque table

入力回転速度 min ⁻¹ (rpm) Input Revolution/min ギヤサイズ Gear	入力トルク (N・m) Input Torque (N・m)									
	商品記号 Catalogue Numbers		250	500	800	1000	1500	2000	2500	3000
BSH 70L - 001	BSH 70T - 001	m 0.8 × 19	0.89	0.89	0.89	0.89	0.86	0.81	0.77	0.73
BSH 85L - 001	BSH 85T - 001	m 1.0 × 19	1.95	1.95	1.95	1.95	1.81	1.69	1.59	1.50
BSH 95L - 001	BSH 95T - 001	m 1.25 × 18	3.68	3.68	3.68	3.58	3.30	3.04	2.85	2.77
BSH 115L - 001	BSH 115T - 001	m 1.5 × 19	5.23	5.23	5.15	5.01	4.69	4.40	4.25	4.13
BSH 120L - 001	BSH 120T - 001	m 1.5 × 19	5.23	5.23	5.15	5.01	4.69	4.40	4.25	4.13
BSH 140L - 001	BSH 140T - 001	m 2.0 × 19	13.30	13.30	12.62	12.17	11.18	10.70	10.30	-
BSH 145L - 001	BSH 145T - 001	m 2.0 × 19	13.30	13.30	12.62	12.17	11.18	10.70	10.30	-
BSH 165L - 001		m 2.5 × 19	26.15	25.63	23.93	22.86	21.25	20.26	-	-
BSH 170L - 001		m 2.5 × 19	26.15	25.63	23.93	22.86	21.25	20.26	-	-

B-BOX® ビーボックス

B-BOXES (BSH)

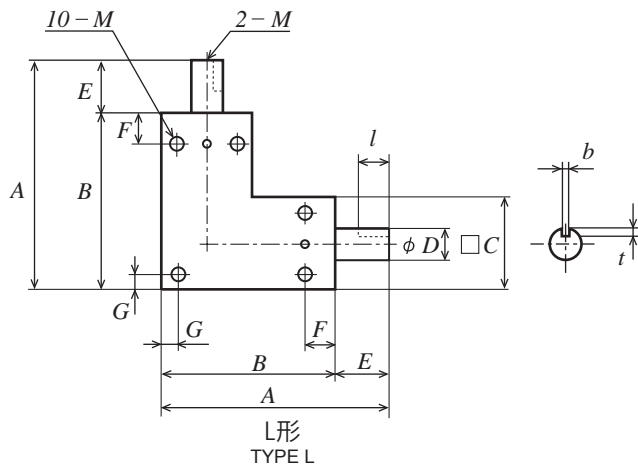

L形
TYPE L

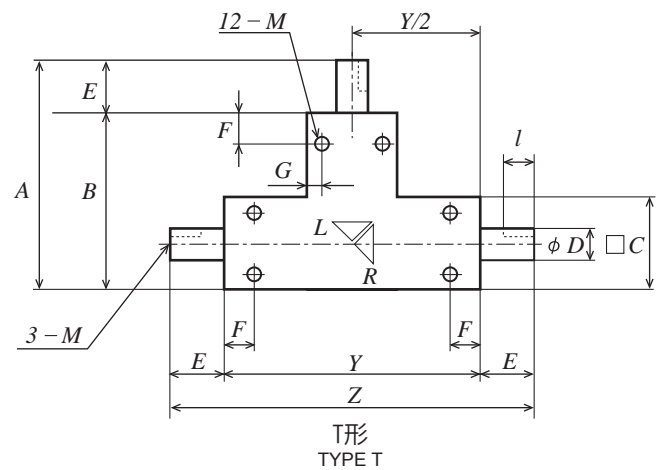

T形
TYPE T

ボディ (A6063、A6061) (FC200、FC250)

Material : Body-Aluminium (ISO AlMg0.7Si, AlMg1SiCu) and Grey Iron Castings (JIS G5501 FC200, FC250)

シャフト (SUS303) (S45C)

Shaft-Stainless and Carbon steels

単位 : mm
Dimensions : mm

F	G	キーみぞ Key Way			取付けねじ Set Screw		軸端ねじ Set Screw of shaft end		バック ラッシュ Backlash (')	オーバーハング 荷重許容 Maximum overhang load (N)	重量 Weight W(kg)	商品記号 Catalogue Number
		b	t	l	M	深さ Depth	2-M	深さ Depth				
9	4	-	-	-	10-M4	6	-	-	15	25	0.2	BSH 70L - 001
10	5	3	1.8	14	10-M5	7	-	-	15	36	0.4	BSH 85L - 001
13	5	3	1.8	15	10-M5	8	-	-	15	58	0.5	BSH 95L - 001
20	5	4	2.5	20	10-M5	12	2-M4	8	10	83	1.8	BSH 115L - 001
20	5	5	3.0	25	10-M5	12	2-M4	8	10	83	1.8	BSH 120L - 001
25	6	5	3.0	25	10-M6	13	2-M5	10	10	166	3.1	BSH 140L - 001
25	6	6	3.5	30	10-M6	13	2-M5	10	10	166	3.2	BSH 145L - 001
25	7	6	3.5	30	10-M6	14	2-M5	12	10	245	5.4	BSH 165L - 001
25	7	8	4.0	35	10-M6	14	2-M5	12	10	245	5.5	BSH 170L - 001
9	4	-	-	-	12-M4	6	-	-	15	25	0.3	BSH 70T - 001
10	5	3	1.8	14	12-M5	7	-	-	15	36	0.5	BSH 85T - 001
13	5	3	1.8	15	12-M5	8	-	-	15	58	0.7	BSH 95T - 001
20	5	4	2.5	20	12-M5	12	2-M4	8	10	83	2.0	BSH 115T - 001
20	5	5	3.0	25	12-M5	12	2-M4	8	10	83	2.0	BSH 120T - 001
25	6	5	3.0	25	12-M6	13	2-M5	10	10	166	3.4	BSH 140T - 001
25	6	6	3.5	30	12-M6	13	2-M5	10	10	166	3.5	BSH 145T - 001

特殊仕様および追加工（使用環境、オイルリーク対策、軸径追加工等取付方法）についてはご相談下さい。
Please do not hesitate to contact us for special method of installation, checking on the usage environment and work out of oil leaks.



図 オーバーハング荷重位置
Load position of overhang.

B-SET ビーセット

B-SETS

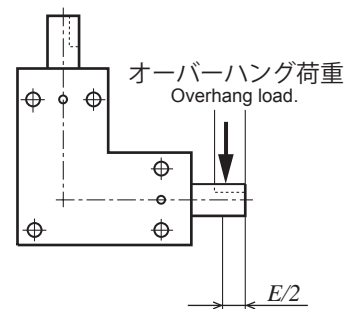

ボディー (A5056、A6063) アルミニウム 黒色アルマイト処理 シャフト (SUS303)
Material : Body-Aluminium (ISO AlMg5, AlMg0.7Si) with Anodize treated Shaft-Stainless steel

単位 : mm
Dimensions : mm

商品記号 Catalogue Number	レシオ Gear Ratio	A	B	C	軸径 Shaft $\phi D(h8)$	E	F	G	H	I
BE40 L - 001	1	40	30	10	$\phi 4$	10	5	4.5	20.5	15
BE55 L - 001	1	55	40	13	$\phi 5$	15	6.5	5	28.5	21.5
BE70 L - 001A	1	70	50	16	$\phi 6$	20	8	6	36	27
BE70 L - 001B	1	70	50	16	$\phi 8$	20	8	6	36	27
BE88 L - 001A	1	88	63	20	$\phi 10$	25	10	7	46	33
BE88 L - 001B	1	88	63	20	$\phi 12$	25	10	7	46	33
BE55 L - 002	2	55	40	13	$\phi 5$	15	6.5	5	28.5	21.5
BE70 L - 002A	2	70	50	16	$\phi 6$	20	8	6	36	27
BE70 L - 002B	2	70	50	16	$\phi 8$	20	8	6	36	27
BE88 L - 002A	2	88	63	20	$\phi 10$	25	10	7	46	33
BE88 L - 002B	2	88	63	20	$\phi 12$	25	10	7	46	33

取り付け用ボルト穴 (3-K) はタップ下穴としても使用できます。
(右表 1 をご参照下さい。)

Drilled holes provided on B-SET can be used with hexagon bolt.
Drilled holes can modify according to table 1 for suitable size of screw thread.
Refer to table 1 for drill holes and counter sinks.

許容伝達トルク表

Allowable transfer capability torque table

商品記号 Catalogue Numbers	ギヤサイズ Gear	入力トルク (N・cm) Input Torque (N・cm)			
		50	100	250	500
BE40 L - 001	m 0.5 × 20	9.8	9.7	9.4	9.0
BE55 L - 001	m 0.8 × 20	38.6	38.0	36.5	34.3
BE70 L - 001A	m 1.0 × 20	72.3	71.0	67.6	62.6
BE70 L - 001B	m 1.0 × 20	72.3	71.0	67.6	62.6
BE88 L - 001A	m 1.5 × 20	232.3	226.5	210.8	188.9
BE88 L - 001B	m 1.5 × 20	232.3	226.5	210.8	188.9
BE55 L - 002	m 0.6 × 14/28	10.5	10.4	10.2	9.9
BE70 L - 002A	m 0.8 × 13/26	20.7	20.6	20.1	19.3
BE70 L - 002B	m 0.8 × 13/26	20.7	20.6	20.1	19.3
BE88 L - 002A	m 1.25 × 13/26	74.2	73.2	70.3	65.9
BE88 L - 002B	m 1.25 × 13/26	74.2	73.2	70.3	65.9

ギヤ素材は S45C を採用しております。
レシオが 2 の場合はピニオン軸の回転数および入力トルクを示しています。
The gear ratio 1 : 2, table shown input revolution and torque on the pinion shaft.

B-SET ビーセット

B-SETS

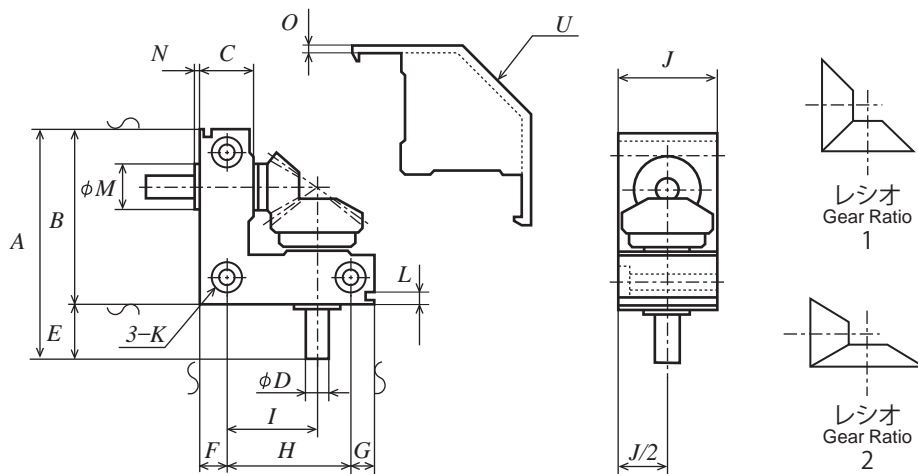

ボディー (A5056、A6063) アルミニウム 黒色アルマイト処理 シャフト (SUS303)
 Material : Body-Aluminium (ISO AlMg5, AlMg0.7Si) with Anodize treated Shaft-Stainless steel

単位 : mm
 Dimensions : mm

J	Counter Sinks & Drill Holes 3-K			L	M	N	O	U	重量 Weight W(g)	商品記号 Catalogue Number
	キリ穴 Drill Hole Diameter	サグリ径 Counter Sink Diameter	サグリ深さ Counter Sink Depth							
18	φ3.4	φ6.5	3.5	2.5	φ 7	2.1	1.7	C13	30	BE40 L - 001
25	φ3.4	φ6.5	3.5	4	φ 9	1.8	1.9	C16	85	BE55 L - 001
30	φ4.3	φ8	4.5	4.5	φ11	1.8	2.1	C20	155	BE70 L - 001A
30	φ4.3	φ8	4.5	4.5	φ14	2	2.1	C20	170	BE70 L - 001B
40	φ5.2	φ9.5	5.5	5	φ18	2	2.1	C27	375	BE88 L - 001A
40	φ5.2	φ9.5	5.5	5	φ19	2.2	2.1	C27	380	BE88 L - 001B
25	φ3.4	φ6.5	3.5	4	φ 9	1.8	1.9	C16	80	BE55 L - 002
30	φ4.3	φ8	4.5	4.5	φ11	1.8	2.1	C20	140	BE70 L - 002A
30	φ4.3	φ8	4.5	4.5	φ14	2	2.1	C20	165	BE70 L - 002B
40	φ5.2	φ9.5	5.5	5	φ18	2	2.1	C27	345	BE88 L - 002A
40	φ5.2	φ9.5	5.5	5	φ19	2.2	2.1	C27	375	BE88 L - 002B

プラスチックカバーが付属しております。
 There is a B-SET with plastic cover.

表 1

Table 1

商品記号 Catalogue Numbers	キリ穴 Drill hole diameter	適合六角穴付ボルト Acceptable hexagon head bolt	タップ追加の場合 Modification of screw thread	追加加工許容最大穴径 Limitation of drill holes
BE 40 L	φ3.4	M3	M4	追加加工不可 Not advisable
BE 55 L	φ3.4	M3	M4	φ5
BE 70 L	φ4.3	M4	M5	φ6
BE 88 L	φ5.2	M5	M6	φ8

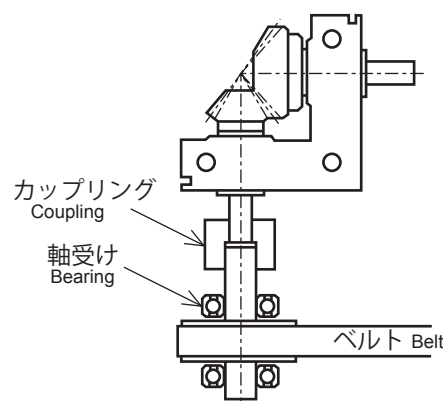

参考図 1
 Reference drawing 1

目次
CONTENTS

インフォメーション
INFORMATION

ギヤボックスマズメ
GEAR BOXES

ノーバッキングギヤ
ANTI BACKLASH SPUR GEARS

歯形歯
GROUND SPUR GEARS

平歯車
SPUR GEARS

内歯車
INTERNAL GEARS

歯形ラック
GROUND RACKS

ラック
RACKS

へリカル・スクリューギヤ
HELICAL GEARS AND SCREW GEARS

ワーム・マニウムギヤ
WORMS AND WORM WHEELS

かさ歯車
BEVEL GEARS

スプロケット
SPROCKETS

技術資料
REFERENCE DATA

W-BOX ウォームボックス

WORM-BOXES

目次
CONTENTS

インフォメーション
INFORMATION

ギヤボックス
GEAR BOXES

ノーバッキング
ANTI BACKLASH SPUR GEAR

歯車
GROUND SPUR GEAR

平歯車
SPUR GEAR

内歯車
INTERNAL GEAR

歯車
GROUND RACKS

ラック
RACKS

ヘリカル
HELICAL GEAR AND SCREW GEAR

ウォーム
WORMS AND WORM WHEELS

かさ歯車
BEVEL GEAR

スプロケット
SPURKETS

技術資料
REFERENCE DATA



ボディー (A5052P、A5056) アルミニウム 黒色アルマイト処理 シャフト (S45C)
Material : Body-Aluminium (ISO AlMg2.5, AlMg5) with Anodize treated Shaft Carbon steel

単位 : mm
Dimensions : mm

商品記号 Catalogue Number	レシオ Gear Ratio	A	B	ボディーサイズ Body Size			軸長 Shaft Length		軸径 Shaft		中心距離 Center Distance J
				C	D	E	F	G	$\phi H(h7)$	$\phi I(h7)$	
WS 55R - 020	20	55	45	45	45	35	10	10	$\phi 5$	$\phi 8$	9.5
WS 55R - 030	30	55	45	45	45	35	10	10	$\phi 5$	$\phi 8$	12
WS 60R - 040	40	60	50	55	50	40	10	10	$\phi 5$	$\phi 8$	14.5
WS 60R - 050	50	60	50	55	50	40	10	10	$\phi 5$	$\phi 8$	17
WS 65R - 020	20	65	55	55	50	40	15	15	$\phi 6$	$\phi 8$	13.2
WS 65R - 030	30	65	55	55	50	40	15	15	$\phi 6$	$\phi 8$	17.2
WS 75R - 040	40	75	60	70	60	45	15	15	$\phi 6$	$\phi 10$	21.2
WS 75R - 050	50	75	60	70	60	45	15	15	$\phi 6$	$\phi 10$	25.2
WS 80R - 010	10	80	65	70	60	45	20	20	$\phi 8$	$\phi 10$	18
WS 80R - 020	20	80	65	70	60	45	20	20	$\phi 8$	$\phi 10$	18
WS 80R - 030	30	80	65	70	60	45	20	20	$\phi 8$	$\phi 12$	23
WS 90R - 040	40	90	75	85	70	50	20	25	$\phi 8$	$\phi 15$	28
WS 90R - 050	50	90	75	85	70	50	20	25	$\phi 8$	$\phi 15$	33

許容伝達入力トルク表

Allowable transfer capability input torque table

入力回転速度 min ⁻¹ (rpm) Input Revolution/min ギヤサイズ Gear 商品記号 Catalogue Numbers		入力トルク (N・cm) Input Torque (N・cm)							
		50	100	500	1,000	1,500	2,000	2,500	3,000
WS 55R - 020	m 0.5 × 1/20	4.0	3.5	2.0	1.5	1.2	1.0	0.9	0.9
WS 55R - 030	m 0.5 × 1/30	5.7	4.9	3.0	2.2	1.8	1.6	1.4	1.3
WS 60R - 040	m 0.5 × 1/40	7.3	6.3	4.0	3.0	2.5	2.1	1.9	1.8
WS 60R - 050	m 0.5 × 1/50	8.9	7.7	4.9	3.7	3.0	2.7	2.2	2.2
WS 65R - 020	m 0.8 × 1/20	9.9	8.5	5.1	3.9	3.1	2.7	2.5	2.3
WS 65R - 030	m 0.8 × 1/30	14.1	12.3	7.6	5.7	4.8	4.2	3.7	3.5
WS 75R - 040	m 0.8 × 1/40	18.0	15.8	9.9	7.5	6.3	5.5	5.0	4.6
WS 75R - 050	m 0.8 × 1/50	21.9	18.9	12.3	9.3	7.9	6.9	6.3	5.8
WS 80R - 010	m 1.0 × 2/20	34.5	29.7	16.9	12.7	10.4	9.1	8.1	7.3
WS 80R - 020	m 1.0 × 1/20	24.9	21.4	12.0	8.9	7.2	6.3	5.6	5.1
WS 80R - 030	m 1.0 × 1/30	35.2	30.6	17.8	13.1	10.8	9.5	8.5	7.8
WS 90R - 040	m 1.0 × 1/40	45.1	39.0	23.3	17.2	14.3	12.6	11.3	10.4
WS 90R - 050	m 1.0 × 1/50	54.7	47.4	28.6	21.4	17.7	15.6	14.1	12.9

入力軸(ウォーム軸) ϕH が出力軸(ホイール軸) ϕI よりも下に来る使用方法と異なる使用方法の場合は、「許容伝達入力トルク表」及び「許容伝達出力トルク表」の値の75%以下でご利用下さい。
 Precaution (Method of assembly of W BOX) It is not advisable to design the input shaft ϕH (axis of worm gear) on top of output shaft ϕI .
 Always make sure the location of output shaft ϕI (axis of Worm wheel) is higher than input shaft ϕH .

W-BOX ウォームボックス

WORM-BOXES

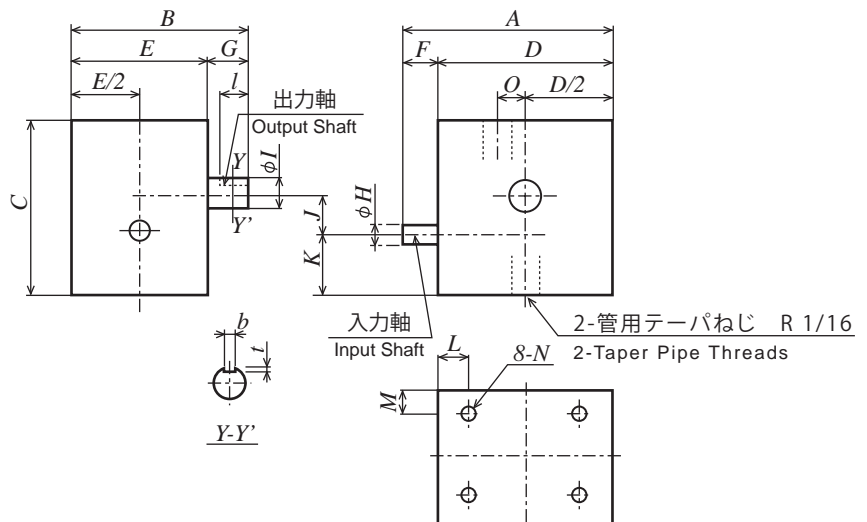

ボディー (A5052P、A5056) アルミニウム 黒色アルマイト処理 シャフト (S45C)
Material : Body-Aluminium (ISO AlMg2.5, AlMg5) with Anodize treated Shaft Carbon Steel

単位 : mm
 Dimensions : mm

K	L	M	取付けねじ Set Screw		キーみぞ Key Way			管用テーパ ねじ Taper Pipe Thread O	バック ラッシ Backlash (')	オーバーハング 荷重許容 Maximum overhang load (N)	重量 Weight W(kg)	商品記号 Catalogue Number
			8-N	深さ Depth	b	t	l					
16.5	8	7	8-M3	6	3	1.8	8	0	25	24	0.23	WS 55R - 020
16.5	8	7	8-M3	6	3	1.8	8	0	25	24	0.23	WS 55R - 030
20	8	8	8-M3	6	3	1.8	8	0	25	24	0.34	WS 60R - 040
19	8	8	8-M3	6	3	1.8	8	8	25	24	0.36	WS 60R - 050
20.9	10	8	8-M4	6	3	1.8	12	0	25	20	0.36	WS 65R - 020
18.9	10	8	8-M4	6	3	1.8	12	8	25	20	0.38	WS 65R - 030
24	10	8	8-M4	8	3	1.8	12	0	25	33	0.60	WS 75R - 040
20	10	8	8-M4	8	3	1.8	12	15	25	33	0.64	WS 75R - 050
26	10	5	8-M5	10	3	1.8	15	0	25	24	0.61	WS 80R - 010
26	10	5	8-M5	10	3	1.8	15	0	25	24	0.61	WS 80R - 020
23.5	10	5	8-M5	10	4	2.5	15	8	25	44	0.65	WS 80R - 030
28.5	10	5	8-M5	10	5	3	20	10	25	58	0.98	WS 90R - 040
21	10	5	8-M5	10	5	3	20	17	25	58	1.02	WS 90R - 050

許容伝達出力トルク表

Allowable transfer capability output torque table

バックラッシは出力軸側のバックラッシとなります
 Backlash : Measured at output shaft

入力回転速度 min ⁻¹ (rpm) Input Revolution/min	出力トルク (N・cm) Output Torque (N・cm)							
	50	100	500	1,000	1,500	2,000	2,500	3,000
商品記号 Catalogue Numbers								
WS 55R - 020	27.8	25.2	18.0	14.7	13.0	11.7	10.8	10.0
WS 55R - 030	59.3	54.2	39.6	32.7	29.7	26.6	24.4	23.0
WS 60R - 040	101.7	92.8	69.4	57.7	51.3	46.9	43.5	41.1
WS 60R - 050	153.0	140.2	106.9	89.3	79.2	72.9	67.7	63.9
WS 65R - 020	84.5	75.9	53.4	44.5	37.8	35.0	32.4	30.6
WS 65R - 030	179.3	164.2	119.5	98.2	86.8	79.3	73.6	69.2
WS 75R - 040	306.0	281.4	207.0	172.6	153.6	139.0	129.9	122.4
WS 75R - 050	465.2	424.5	319.5	266.4	238.4	217.8	202.2	192.5
WS 80R - 010	191.7	171.1	112.8	90.5	77.5	69.3	63.0	58.4
WS 80R - 020	192.4	174.6	120.5	98.2	85.7	78.2	72.0	67.1
WS 80R - 030	409.1	374.0	265.7	218.2	191.7	175.2	162.8	152.8
WS 90R - 040	697.4	638.0	463.9	382.7	337.5	309.6	288.2	271.1
WS 90R - 050	1,056.7	968.1	713.2	591.9	522.9	479.7	447.4	421.7

※写真、及び、寸法図は、入力軸 (ウォーム軸) φ H が出力軸 (ホイール軸) φ l よりも下に来るレイアウトの使用例です。
 Refer to picture and drawing. This is an example of usage for input shaft φ H (axis of worm gear) is lower than output shaft φ l (axis of Worm wheel).



図 オーバーハング荷重位置
 および軸の回転方向

Load position of overhang
 and direction of the rotation.

W-BOX 使用上の注意

Precaution of usage for KG W-BOX

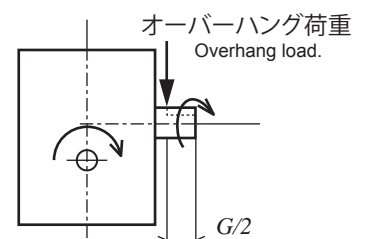
1) なじみ運転

W-BOX はご使用を開始する前になじみ運転として通常負荷の 1/2 ~ 1/3 を目安に約 6 時間以上行う事を推奨いたします。

2) 潤滑油交換

潤滑油は ISO VG680 相当をご使用下さい。

運転開始後、累積時間が約 50 時間を目安として初回潤滑油交換を行って下さい。

以降は 6 ヶ月に 1 度の間隔で油量、汚れを点検し必要に応じて交換して下さい。

交換の際には W-BOX のボディ及び油の温度が高温になっている場合がありますのでご注意ください。

3) 自働締り（セルフロック）

W-BOX は基本的にセルフロックは効きません。

確実に止めたいときは別に安全装置（ロック機構、廻り止め）を設けて下さい。

4) 異音発生時

通常運転時と違った音が発生した場合や、振動が大きくなった場合は、運転を中止し、手廻しで回転の軽い / 重いを確認し、ジャリジャリ音がする場合は潤滑油の入れ替えを行って下さい。

5) 高温状態

室温 + W-BOX 表面温度が 80℃ 以上になった場合、運転を中止し潤滑油の入れ替えまたは運転条件の再確認が必要です。

1) Warm up and test run

To warm up and test run for W-BOXES, we recommended applying 1/2 to 1/3 of normal loads for over 6 hour before actual operation.

2) Change of lubricating oil

Use lubricating oil equivalent to ISO VG680 is recommended.

When the machine runs over 50 accumulated hours, this is the tentative deadline to replace the initial lubricating oil.

Subsequently, check the amount of lubricating oil and dirt of oil every 6 months. Replace lubrication oil if necessary.

At the times of changing of lubrication oil, beware of heated body and oil temperature of W-BOX will increase.

3) Self lock

Basically self-locks function will not activate for W-BOXES.

For all range of W-BOXES, in order that the suspension of load to function properly, safety device such as lock device, one-way clutch and others are recommend to be built in separately.

4) Precaution of unusual noise

Stop the operation and check for fault if there are any occurrences such as unusual noise or unbalanced oscillation from W-BOX.

Check the shaft's resistance by manually turning a micro coupling between motor and W-BOX to check the gritty-noise from W-BOX, please replace the lubrication oil if necessary.

5) Over heated W-BOX

Stop operation and check the temperature of W-BOX when the temperature of W-BOX is over 80℃ (Celsius). Replace lubricating oil and check the conditions of operation if necessary.



ノーバックラッシギヤ コントロールバックラッシギヤ

Anti Backlash Spur Gears

商品記号の読み方 Reference of Catalogue Number

NS 50 AL 60 B + 08 08
 NSG 80 S 80 B + 08 10
 ASG 1 S 70 B - 10 12

歯車の種類 / 歯面仕上 Kind of Gear	モジュール Module	材質 Material	歯数 Number of Teeth	形状 Type	穴仕上 Bores Processed	歯幅 Face Width	穴径 Bore Diameter
NS : ノーバックラッシギヤ Anti Backlash Gears NSG : 歯研ノーバックラッシギヤ Anti Backlash Ground Gears ASG : コントロールバックラッシギヤ Control Backlash Ground Gears	m : 0.5 0.8 1.0 1.5 2.0 Expressed the unit of module's size. Module 0.5 and 0.8 as multiple of 100. Example m0.5 → 50 m0.8 → 80	AL : アルミニウム Aluminium S : S45C Carbon Steel S : SCM435、440 (ASG) Chromium Molybdenum Steel SU : SUS304 Stainless Steel	z : 50 ~ 120 (ASG) 30 ~	B : ハブ付き With Hub on one side.	【+】 : ネジ穴付 NS 旋削加工 Machined bore NSG 研削仕上 Ground bore Gear with Thread hole / without Set Screw. 【-】 : キーみぞ ネジ穴無し ASG 研削仕上 Ground bore Gear without Thread hole / without Key Way.	単位 : ミリメートル Dimension : millimeter	単位 : ミリメートル Dimension : millimeter

メカトロ産業の発達に伴ないバックラッシを『0』にしたいというニーズにお応えします。
メカトロ、精密機器等の『遊びが0』を必要とする分野に不可欠のものです。

Anti Backlash Spur Gears can provide support to HI-TECH Mechanical, Electrical and Electronics products.
It reduces the backlash to zero [0]. An essential product for Mechanical, Electrical and Precision products.

当社規格のノーバックラッシギヤ コントロールバックラッシギヤの主な特徴 Feature of Anti Backlash Spur Gears

- 1) 小モジュールサイズ中心です。
- 2) 材質はアルミニウム、S45C、SCM435、440、SUS304 等があります。
(コントロールバックラッシギヤは SCM435 or 440 です)
- 3) 相手歯車は当社歯研平歯車、平歯車をご使用下さい。

- 1) The variations are from module 0.5 to 2.0.
- 2) Materials : Aluminium, Carbon Steel, Chromium Molybdenum Steel, Stainless Steel.
- 3) KG-Anti Backlash Spur Gear is able to match with other makers, however it is advisable to use KG-Ground Spur Gear series and KG-Spur Gear Series for best result.

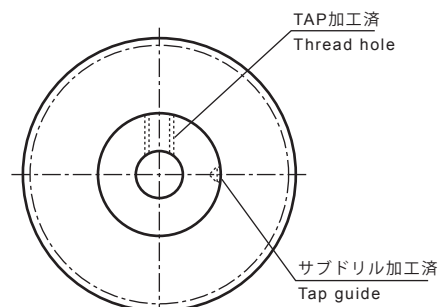

(ASGシリーズを除く)
(Excluded ASG Series)

主なノーバックラッシギヤ機構

Mechanism of anti Backlash Spur Gears

1. 固定形 (当社 ASG シリーズ)

Fixed type (ASG series)

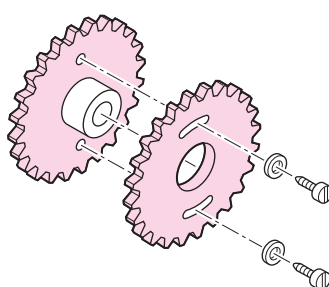
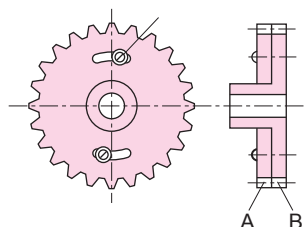

相手歯車と組み立てる際に、ボルトを緩めて、AとBをずらし相手の歯を挟み込みます。バックラッシを最小限に取り除いてからボルトを締めて固定します。この方法は、歯車の精度が高いことが必要です。

Method of ASG series is to loosen the bolts, then adjust gear A and gear B. This adjustment will allow to slip gear A and B into the match gear at a minimum backlash before tightening the bolt. This ASG series is only suitable for application that needs minimal backlash adjustment and the match gear needs to be high quality.

2. 円弧ばね形 (当社 BS 形)

Circular Arc Spring type (Type BS)

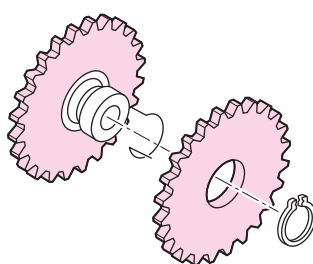
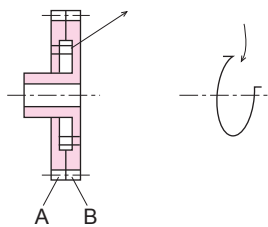

円弧ばねをAとBとの間に入れてばねの力によって、バックラッシを取り除く方法で、使い方は固定形と同様に、相手の歯を挟み込んで使用します。この方法は比較的に伝達トルクの小さい部分に使用されます。

Method of BS series is using a Circular Arc Spring to place between gear A and B in order to eliminate the backlash. BS series gears are allowable for low torque application.

3. コイルばね形 (当社 BW 形)

Coiled Spring type (Type BW)

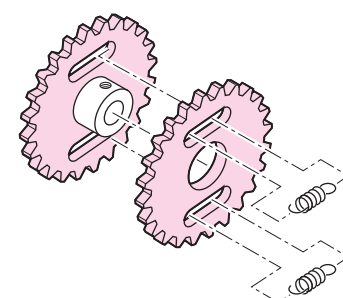
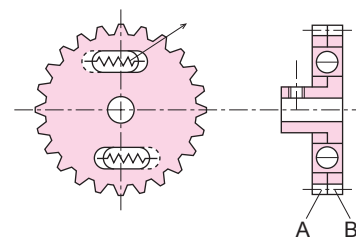

円弧ばね形と同様にAとBとをコイルばねでつりあわせ、AとBとをずらして相手の歯を挟み込んでバックラッシを取り除きます。

Method of BW series is the spring suspension of gear A and B. The tension of spring will allow them to slip relatively to each other by the force. This method will eliminate the backlash once gear A and B engage with the match gear.

歯合せ原点 n0 (0 枚目) の設定方法 Adjustment of zero points as n0.

ノーバックラッシュギヤに取り付けられているバネが自由状態（バネに荷重を与えていない状態）のとき、歯車 A と歯車 B の歯の山の位置は一致していません。

歯合せ原点 n0 (0 枚目) の設定方法は、歯車 B を固定し BS 形の場合は歯車 A の側面に刻印されている矢印の方向へ、又、BW 形の場合は取り付けられている引っ張りバネが引っ張られる方向へ徐々に回転させ全てのバネが張り初めて歯車 A と歯車 B の歯の山が一致したところを原点 n0 (0 枚目) とします。

- 1) For selection NS and NSG series, refer to the Allowable Transfer Capability Torque Table.
- 2) For NS and NSG, all adjustments are similar.

Rotate the gear with arrow mark indicator to zero point until both gear teeth are fully match with no tension of spring. At zero point pitch where both gear teeth match, rotate two (2) pitches or more according to Allowable Transfer Capability Torque Table.

- 3) Reference to the Table provided, do not exceed the load maximum limitation of Anti Backlash function.

希望の許容トルクへの設定方法 Method for settlement of Allowable Transfer Torque.

1 ピッチずらし量の選択方法

NS、NSG シリーズよりご使用条件に合う商品記号を選択します。次に許容伝達トルク早見表より選択した商品記号の欄から希望するトルク値以上の許容伝達トルク値となるピッチずらし量：n の数値を選択します。

NSU シリーズの場合はピッチずらし量：n の数値を n = 2 (2 枚ずらし) にてご使用下さい。NSU シリーズの許容伝達トルク表の値にてご使用いただけます。

2 希望の許容トルクの設定方法

「歯合せ原点 n0 (0 枚目) の設定方法」にて歯車 A と歯車 B の歯の山を一致させた原点 n0 (0 枚目) から許容伝達トルク表より選択したピッチずらし量：n のピッチ数だけ歯車 A の歯の山をさらにずらし相手歯車とかみ合わせる事により希望の許容トルク値にてご使用いただけます。

Method of Shifting pitch(n)

Firstly, select suitable Anti backlash Spur Gears from NS and NSG series. Secondly, find the numerical value of shifting pitch of your required torque from the Allowable Transfer Capability Torque Table (Chart).

Example: Your existing require NSG part number is NSG50S 60B+0808, your existing torque speed is 15N per cm, you need to shift 3 pitch in order to get the next largest value inside the Allowable Transfer Capability Torque Table (Chart) and assembly to match your existing gear.

For NSU series, there is a limitation to the shifting of the pitch as according to the Allowable Transfer Capability Torque Table (Chart). The minimum and maximum requirement for the shifting are allowable at 2 pitches.

Memo

目次
CONTENTS

インフォメーション
INFORMATION

ギヤボックス
GEAR BOXES

ノーバックラッシュギヤ
ANTI BACKLASH SPUR GEARS

歯研平歯車
GROUND SPUR GEARS

平歯車
SPUR GEARS

内歯車
INTERNAL GEARS

歯研ラック
GROUND RACKS

ラック
RACKS

ヘリカル・スクリューギヤ
HELICAL GEARS AND SCREW GEARS

ウォーム・ウォームホイール
WORMS AND WORM WHEELS

かさ歯車
BEVEL GEARS

スプロケット
SPURKETS

技術資料
REFERENCE DATA

ノーバックラッシュギヤ

ANTI BACKLASH SPUR GEARS

モジュール
MODULE

0.5

圧力角 20° (並歯)

20° PRESSURE ANGLE FULL DEPTH TOOTH



御注文には必ず“フルネームで商品記号”を明記してください。
Please refer to the catalogue reference while ordering.

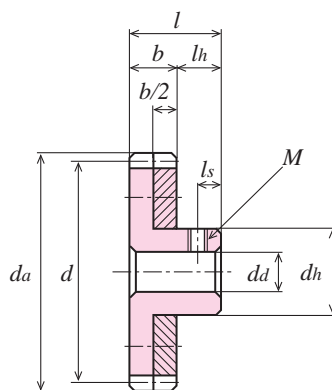

BW形 (当図は略図です)
The above sketch is for reference only.
TYPE BW

NSU シリーズ NSU Series 歯面切削仕上

Material : Stainless Steel SUS304 (JIS G 4303)

単位 : mm
Dimensions : mm

商品記号 Catalogue Number	材質 Material	モジュール Module	歯数 Number of Teeth	基準円直径 Reference Diameter	歯先円直径 Tip Diameter	形 Type	ばね数 Number of Springs	歯幅 Face Width	穴径 Bore Diameter	ハブ外径 Hub Diameter	ハブ長さ Hub Projection	全長 Overall Length	ねじ Set Screw		重量 Weight
													M	ls	
NS50SU 60B + 0505	SUS304	0.5	60	φ30	φ31	BW	2	5	φ 5	φ12	8	13	M3	4	32.3
NS50SU 70B + 0508	SUS304	0.5	70	φ35	φ36	BW	2	5	φ 8	φ16	8	13	M3	4	45.7
NS50SU 80B + 0508	SUS304	0.5	80	φ40	φ41	BW	3	5	φ 8	φ16	8	13	M3	4	57.4
NS50SU 90B + 0510	SUS304	0.5	90	φ45	φ46	BW	3	5	φ10	φ20	8	13	M4	4	74.9
NS50SU 100B + 0510	SUS304	0.5	100	φ50	φ51	BW	3	5	φ10	φ20	8	13	M4	4	89.7
NS50SU 120B + 0510	SUS304	0.5	120	φ60	φ61	BW	4	5	φ10	φ20	8	13	M4	4	123.9

セットスクリューが付いております。(材質はステンレスではありません) [+]: Gear with Thread hole / with Set Screw. (not SUS)

『使用上の注意』

- NSU シリーズの場合、NS、NSG シリーズと異なり相手ギヤとかみ合わせる時のピッチずらし量:nは歯合せ原点n0 (0 枚目) より n2 (2 枚) ピッチずらしにてご使用下さい。許容伝達トルク表の値にてご使用いただけます。
- NSU シリーズの場合、材質に SUS304 を使用しているためカブリ防止、およびスムーズに摺動させるためにテフロン系の表面処理を施しております。

Precaution of Usage

- For NSU series, there is a limitation to the shifting of the pitch as according to the Allowable Transfer Capability Torque Table (Chart). The required shifting allowed is two pitch only.
- NSU series for all stainless steel are completed with Teflon coating that will prevent scuffing and provide smooth motion.

Method of adjustment of zero point.

Rotate the gear with arrow mark indicator to zero point until both gear teeth are fully match with no tension of spring.

許容伝達トルク表

Allowable transfer capability torque table

商品記号 Catalogue Numbers	許容伝達トルク (N・cm)	
	Limitation of anti backlash to Funciton (N・cm)	
	n2	
NS50SU 60B + 0505	9.71	
NS50SU 70B + 0508	11.17	
NS50SU 80B + 0508	16.18	
NS50SU 90B + 0510	19.49	
NS50SU 100B + 0510	30.69	
NS50SU 120B + 0510	39.85	

n はピッチずらし量 Amount of shifting pitch.

目次
CONTENTS

インフォメーション
INFORMATION

ギヤボックス
GEAR BOXES

ノーバックラッシュギヤ
ANTI BACKLASH SPUR GEARS

歯研平歯車
GROUND SPUR GEARS

平歯車
SPUR GEARS

内歯車
INTERNAL GEARS

歯研ラック
GROUND RACKS

ラック
RACKS

へリカル・スクリューギヤ
HELICAL GEARS AND SCREW GEARS

ウォーム・ウォームギヤ
WORMS AND WORM GEARS

かさ歯車
BEVEL GEARS

スプロケット
SPROCKETS

技術資料
REFERENCE DATA

ノーバックラッシュギヤ

ANTI BACKLASH SPUR GEARS

モジュール **0.5/0.8/1** 圧力角 20° (並歯)
 MODULE 20° PRESSURE ANGLE FULL DEPTH TOOTH

目次 CONTENTS

インフォメーション INFORMATION

ギヤボックス GEAR BOXES

ノーバックラッシュギヤ ANTI BACKLASH SPUR GEARS

歯車平歯車 GROUND SPUR GEARS

平歯車 SPUR GEARS

内歯車 INTERNAL GEARS

歯車ラック GROUND RACKS

ラック RACKS

へリカルスクリューギヤ WORMS AND WORM WHEELS

かさ歯車 BEVEL GEARS

スプロケット SPROCKETS

技術資料 REFERENCE DATA



御注文には必ず“フルネームで商品記号”を明記してください。
 Please refer to the catalogue reference while ordering.

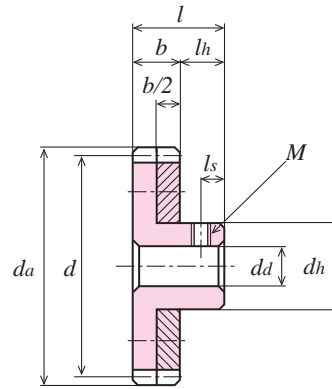

B S, B W形 (当図は略図です)
 The above sketch is for reference only.
 TYPE BS, BW

NS シリーズ NS Series 歯面切削仕上

Material : Aluminium (JIS A5056) Carbon Steel (ISO C45)

単位 : mm
 Dimensions : mm

商品記号 Catalogue Number	材質 Material	モジュール Module	歯数 Number of Teeth	基準円直径 Reference Diameter	歯先円直径 Tip Diameter	形 Type	ばね数 Number of Springs	歯幅 Face Width	穴径 Bore Diameter	ハブ外径 Hub Diameter	ハブ長さ Hub Projection	全長 Overall Length	ねじ Set Screw		重量 Weight
													M	ls	
NS50AL 60B + 0808	AL	0.5	60	φ 30	φ 31	BS	1	8	φ 8	φ 16	8	16	M4	4	16
NS50AL 70B + 0808	AL	0.5	70	φ 35	φ 36	BS	1	8	φ 8	φ 16	8	16	M4	4	21
NS50AL 80B + 0808	AL	0.5	80	φ 40	φ 41	BS	1	8	φ 8	φ 20	8	16	M4	4	30
NS50AL 90B + 0810	AL	0.5	90	φ 45	φ 46	BS	1	8	φ 10	φ 20	8	16	M4	4	36
NS50AL 100B + 0810	AL	0.5	100	φ 50	φ 51	BS	1	8	φ 10	φ 20	8	16	M4	4	44
NS50AL 120B + 0810	AL	0.5	120	φ 60	φ 61	BS	1	8	φ 10	φ 20	8	16	M4	4	62
NS80AL 50B + 0810	AL	0.8	50	φ 40	φ 41.6	BS	1	8	φ 10	φ 20	10	18	M5	5	30
NS80AL 60B + 0810	AL	0.8	60	φ 48	φ 49.6	BS	1	8	φ 10	φ 20	10	18	M5	5	42
NS80AL 70B + 0810	AL	0.8	70	φ 56	φ 57.6	BS	1	8	φ 10	φ 20	10	18	M5	5	52
NS80S 80B + 0810	S	0.8	80	φ 64	φ 65.6	BW	2	8	φ 10(H7)	φ 20	10	18	M5	5	200
NS80S 90B + 0810	S	0.8	90	φ 72	φ 73.6	BW	2	8	φ 10(H7)	φ 20	10	18	M5	5	253
NS80S 100B + 0810	S	0.8	100	φ 80	φ 81.6	BW	2	8	φ 10(H7)	φ 24	10	18	M5	5	324
NS80S 120B + 0810	S	0.8	120	φ 96	φ 97.6	BW	2	8	φ 10(H7)	φ 24	10	18	M5	5	463
NS1AL 50B + 1010	AL	1.0	50	φ 50	φ 52	BS	1	10	φ 10	φ 20	10	20	M6	5	49
NS1AL 60B + 1010	AL	1.0	60	φ 60	φ 62	BS	1	10	φ 10	φ 20	10	20	M6	5	72
NS1S 70B + 1012	S	1.0	70	φ 70	φ 72	BW	2	10	φ 12(H7)	φ 24	10	20	M6	5	298
NS1S 80B + 1012	S	1.0	80	φ 80	φ 82	BW	2	10	φ 12(H7)	φ 24	10	20	M6	5	390
NS1S 90B + 1012	S	1.0	90	φ 90	φ 92	BW	3	10	φ 12(H7)	φ 24	10	20	M6	5	495
NS1S 100B + 1012	S	1.0	100	φ 100	φ 102	BW	3	10	φ 12(H7)	φ 30	10	20	M6	5	632
NS1S 120B + 1012	S	1.0	120	φ 120	φ 122	BW	3	10	φ 12(H7)	φ 30	10	20	M6	5	903

材質 AL : アルミニウム A5056 (白アルマイト処理) Gear with Anodize treated.
 Materials S : S45C (軟窒化処理) Carbon steel with Isonite treated.

形状 BS : 円弧ばね使用 Circular Arc Spring type
 Type BW : コイルばね使用 Coiled Spring type

セットスクリューが付いております。[+] : Gear with Thread hole / with Set Screw.

許容伝達トルク表

Allowable transfer capability torque table

商品記号 Catalogue Numbers	許容伝達トルク (N・cm) Limitation of anti backlash to Fuction (N・cm)			
	n2	n3	n4	n5
NS50AL 60B + 0808	13.33	21.18	31.08	40.79
NS50AL 70B + 0808	10.86	16.35	24.83	32.72
NS50AL 80B + 0808	11.50	16.47	20.79	26.93
NS50AL 90B + 0810	10.00	14.41	19.12	23.68
NS50AL 100B + 0810	8.16	12.91	17.81	22.55
NS50AL 120B + 0810	7.25	10.39	15.29	18.43

商品記号 Catalogue Numbers	許容伝達トルク (N・cm) Limitation of anti backlash to Fuction (N・cm)			
	n2	n3	n4	n5
NS80AL 50B + 0810	14.12	25.36	32.68	42.09
NS80AL 60B + 0810	13.80	19.77	28.55	35.61
NS80AL 70B + 0810	14.46	18.85	25.26	32.58
NS80S 80B + 0810	46.44	56.48	66.73	76.98
NS80S 90B + 0810	50.36	64.72	76.49	92.49
NS80S 100B + 0810	47.59	61.19	74.53	87.33
NS80S 120B + 0810	43.61	55.23	67.78	80.02
NS1AL 50B + 1010	18.14	27.29	35.13	47.85
NS1AL 60B + 1010	16.86	23.92	31.77	40.99
NS1S 70B + 1012	31.35	41.41	-	-
NS1S 80B + 1012	33.73	46.02	56.48	-
NS1S 90B + 1012	62.66	87.08	103.55	-
NS1S 100B + 1012	74.19	103.29	122.90	145.78
NS1S 120B + 1012	81.19	109.04	139.63	160.81

n: ピッチずらし量 Amount of shifting pitch.

ノーバックラッシギヤ

ANTIBACKLASH GROUND SPUR GEARS

モジュール
MODULE

0.5/0.8/1

圧力角 20° (並歯)

20° PRESSURE ANGLE FULL DEPTH TOOTH

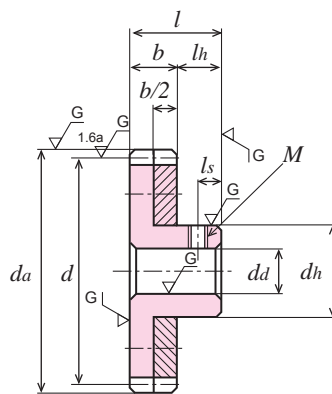

BS, BW形 (当図は略図です)
The above sketch is for reference only.
TYPE BS, BW

NSG シリーズ NSG Series 歯面研削仕上 SCM435、440 クロムモリブデン鋼

Material : Chromium Molybdenum Steel (ISO 34CrMo4, 42CrMo4)

単位 : mm
Dimensions : mm

商品記号 Catalogue Number	材質 Material M	モジュール Module m	歯数 Number of Teeth z	基準円直径 Reference Diameter d	歯先円直径 Tip Diameter da	形 Type	ばね数 Number of Springs	歯幅 Face Width b	穴径 Bore Diameter da(H7)	ハブ外径 Hub Diameter dh	ハブ長さ Hub Projection lh	全長 Overall Length l	ねじ Set Screw		重量 Weight W(g)
													M	ls	
NSG50S 60B + 0808	SCM	0.5	60	φ 30	φ 31	BS	1	8	φ 8	φ 16	8	16	M4	4	45
NSG50S 70B + 0808	SCM	0.5	70	φ 35	φ 36	BS	1	8	φ 8	φ 16	8	16	M4	4	61
NSG50S 80B + 0808	SCM	0.5	80	φ 40	φ 41	BS	1	8	φ 8	φ 20	8	16	M4	4	87
NSG50S 90B + 0810	SCM	0.5	90	φ 45	φ 46	BS	1	8	φ 10	φ 20	8	16	M4	4	105
NSG50S 100B + 0810	SCM	0.5	100	φ 50	φ 51	BS	1	8	φ 10	φ 20	8	16	M4	4	128
NSG50S 120B + 0810	SCM	0.5	120	φ 60	φ 61	BS	1	8	φ 10	φ 20	8	16	M4	4	182
NSG80S 50B + 0810	SCM	0.8	50	φ 40	φ 41.6	BS	1	8	φ 10	φ 20	10	18	M5	5	87
NSG80S 60B + 0810	SCM	0.8	60	φ 48	φ 49.6	BS	1	8	φ 10	φ 20	10	18	M5	5	122
NSG80S 70B + 0810	SCM	0.8	70	φ 56	φ 57.6	BS	1	8	φ 10	φ 20	10	18	M5	5	152
NSG80S 80B + 0810	SCM	0.8	80	φ 64	φ 65.6	BW	2	8	φ 10	φ 20	10	18	M5	5	200
NSG80S 90B + 0810	SCM	0.8	90	φ 72	φ 73.6	BW	2	8	φ 10	φ 20	10	18	M5	5	253
NSG80S 100B + 0810	SCM	0.8	100	φ 80	φ 81.6	BW	2	8	φ 10	φ 24	10	18	M5	5	324
NSG80S 120B + 0810	SCM	0.8	120	φ 96	φ 97.6	BW	2	8	φ 10	φ 24	10	18	M5	5	463
NSG1S 50B + 1010	SCM	1.0	50	φ 50	φ 52	BS	1	10	φ 10	φ 20	10	20	M6	5	144
NSG1S 60B + 1010	SCM	1.0	60	φ 60	φ 62	BS	1	10	φ 10	φ 20	10	20	M6	5	212
NSG1S 70B + 1012	SCM	1.0	70	φ 70	φ 72	BW	2	10	φ 12	φ 24	10	20	M6	5	298
NSG1S 80B + 1012	SCM	1.0	80	φ 80	φ 82	BW	2	10	φ 12	φ 24	10	20	M6	5	390
NSG1S 90B + 1012	SCM	1.0	90	φ 90	φ 92	BW	3	10	φ 12	φ 24	10	20	M6	5	495
NSG1S 100B + 1012	SCM	1.0	100	φ 100	φ 102	BW	3	10	φ 12	φ 30	10	20	M6	5	632
NSG1S 120B + 1012	SCM	1.0	120	φ 120	φ 122	BW	3	10	φ 12	φ 30	10	20	M6	5	903

形状 BS ; 円弧ばね使用 Circular Arc Spring type
Type BW ; コイルばね使用 Coiled Spring type

セットスクリューが付いております。[+] : Gear with Thread hole / with Set Screw.

許容伝達トルク表

Allowable transfer capability torque table

商品記号 Catalogue Numbers	許容伝達トルク (N・cm) Limitation of anti backlash to Function (N・cm)			
	n2	n3	n4	n5
NSG50S 60B + 0808	13.33	21.18	31.08	40.79
NSG50S 70B + 0808	10.86	16.35	24.83	32.72
NSG50S 80B + 0808	11.50	16.47	20.79	26.93
NSG50S 90B + 0810	10.00	14.41	19.12	23.68
NSG50S 100B + 0810	8.16	12.91	17.81	22.55
NSG50S 120B + 0810	7.25	10.39	15.29	18.43

商品記号 Catalogue Numbers	許容伝達トルク (N・cm) Limitation of anti backlash to Function (N・cm)			
	n2	n3	n4	n5
NSG80S 50B + 0810	14.12	25.36	32.68	42.09
NSG80S 60B + 0810	13.80	19.77	28.55	35.61
NSG80S 70B + 0810	14.46	18.85	25.26	32.58
NSG80S 80B + 0810	46.44	56.48	66.73	76.98
NSG80S 90B + 0810	50.36	64.72	76.49	92.49
NSG80S 100B + 0810	47.59	61.19	74.53	87.33
NSG80S 120B + 0810	43.61	55.23	67.78	80.02
NSG1S 50B + 1010	18.14	27.29	35.13	47.85
NSG1S 60B + 1010	16.86	23.92	31.77	40.99
NSG1S 70B + 1012	31.35	41.41	-	-
NSG1S 80B + 1012	33.73	46.02	56.48	-
NSG1S 90B + 1012	62.66	87.08	103.55	-
NSG1S 100B + 1012	74.19	103.29	122.90	145.78
NSG1S 120B + 1012	81.19	109.04	139.63	160.81

n : ピッチずらし量 Amount of shifting pitch.

目次
CONTENTS

インフォメーション
INFORMATION

ギヤボックス
GEAR BOXES

ノーバックラッシギヤ
ANTI BACKLASH SPUR GEARS

歯面研削仕上
GROUND SPUR GEARS

平歯車
SPUR GEARS

内歯車
INTERNAL GEARS

歯面ラック
GROUND RACKS

ラック
RACKS

ハブ・スクリューギヤ
HECAL GEARS AND SCREW GEARS

ウォーム・ウォームギヤ
WORMS AND WORM GEARS

かさ歯車
BEVEL GEARS

スプロケット
SPROCKETS

技術資料
REFERENCE DATA

コントロールバックラッシギヤ

CONTROL BACKLASH GROUND SPUR GEAR

モジュール
MODULE

1/1.5/2

圧力角 20° (並歯)

20° PRESSURE ANGLE FULL DEPTH TOOTH

歯部高周波焼き入れ Hrc49 ~ 55

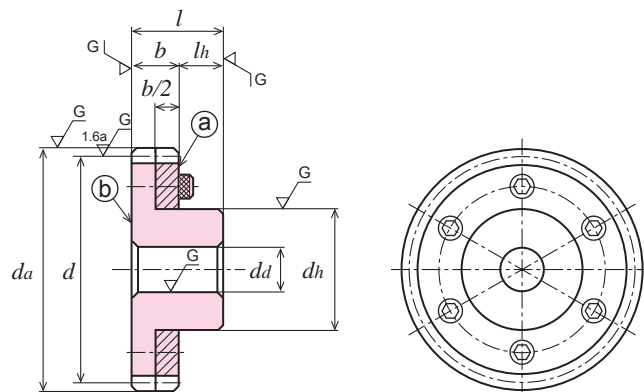

固定形 (当図は略図です)
The above sketch is for reference only.

ASG シリーズ ASG Series 歯面研削仕上げ SCM435、440 クロムモリブデン鋼

Material : Chromium Molybdenum Steel (ISO 34CrMo4, 42CrMo4)

単位 : mm
Dimensions : mm

商品記号 Catalogue Number	材質 Material <i>M</i>	モジュール Module <i>m</i>	歯数 Number of Teeth <i>z</i>	基準円直径 Reference Diameter <i>d</i>	歯先円直径 Tip Diameter <i>da</i>	歯幅 Face Width <i>b</i>	穴径 Bore Diameter <i>da</i> (H7)	ハブ外径 Hub Diameter <i>dh</i>	ハブ長さ Hub Projection <i>lh</i>	全長 Overall Length <i>l</i>	固定ボルト Fixed Bolts	重量 Weight <i>W</i> (kg)
ASG1S 70B - 1012	SCM	1	70	φ 70	φ 72	10	φ12	φ40	10	20	6-M4-φ 54	0.39
ASG1S 80B - 1012	SCM	1	80	φ 80	φ 82	10	φ12	φ45	10	20	6-M4-φ 62	0.51
ASG1S 100B - 1012	SCM	1	100	φ100	φ102	10	φ12	φ60	10	20	6-M5-φ 80	0.82
ASG1S 120B - 1015	SCM	1	120	φ120	φ122	10	φ15	φ80	10	20	6-M5-φ100	1.25
ASG1.5S 40B - 1515	SCM	1.5	40	φ 60	φ 63	15	φ15	φ35	15	30	6-M4-φ 46	0.41
ASG1.5S 50B - 1520	SCM	1.5	50	φ 75	φ 78	15	φ20	φ45	15	30	6-M5-φ 58	0.64
ASG1.5S 60B - 1520	SCM	1.5	60	φ 90	φ 93	15	φ20	φ60	15	30	6-M5-φ 74	1.02
ASG1.5S 80B - 1520	SCM	1.5	80	φ120	φ123	15	φ20	φ80	15	30	6-M6-φ 98	1.85
ASG2S 30B - 2015	SCM	2	30	φ 60	φ 64	20	φ15	φ35	20	40	6-M4-φ 45	0.54
ASG2S 40B - 2020	SCM	2	40	φ 80	φ 84	20	φ20	φ50	20	40	6-M5-φ 62	1.01
ASG2S 50B - 2020	SCM	2	50	φ100	φ104	20	φ20	φ60	20	40	6-M6-φ 78	1.59
ASG2S 60B - 2025	SCM	2	60	φ120	φ124	20	φ25	φ80	20	40	6-M6-φ 98	2.42

Gear tooth surface completed with induction hardening, Hardness HRC49 to 55.

相手歯車は当社歯研平歯車 SG シリーズよりお選びください。
KG-Ground Control Backlash Spur gear is able to match with other gear makers however it is advisable to use KG-Ground Spur gear series for best result.

『使用上の注意』

- ①ギヤと②ギヤの隙間に異物が入らないように注意して下さい。
- 固定用ボルトにて③ギヤと④ギヤを固定する場合、コントロールバックラッシギヤと相手ギヤのバックラッシが最小でかつスムーズに回転できる位置に③ギヤと④ギヤを調整し6本のボルトを適当なトルクにて均等に締め付け固定して下さい。
相手ギヤとコントロールバックラッシギヤを1回転させたときバックラッシ量の不足により回転が重い部分がある場合は再度調整を行って下さい。
- 追加工を行う場合、必ず生づめスクロールチャックを使用し、穴面から芯出しを行って下さい。
仕上げ精度が悪い場合はバックラッシ量を小さく調整できなくなります。また、歯車への打痕、きずにご注意して下さい。
- かみ合せのバックラッシ量を、より小さくしたい場合はコントロールバックラッシギヤと相手ギヤのかみ合う歯を換えて再度バックラッシ量を調整することによりバックラッシ量を、より小さく調整できる場合があります。

Precaution of Usage.

- Before assembly ensure dust free between gear ① and ②.
- Firstly fix gear ③ and ④ to form Ground Control Backlash Gear and put back all the fixed bolts (6 pieces) without tightening.
- Secondly assemble match gear to form Ground Control Backlash Gear, and tighten the fixed bolts (6 pieces) equally space between them. If possible use a dial gauge.
- Ensure to provide minimum backlash between Ground Control Backlash Spur Gear and match gear.
- If unable to obtain your requisite backlash, shift to another position of each gear tooth between Ground Control Backlash Gear and match gear to adjust a less backlash.
- Additional machining for bore is not advisable for our KG-Control Backlash Spur Gears.

許容伝達動力表 曲げ強さ (kW)

Allowable transfer capability table (kW) Bending Strength

商品記号 Catalogue Numbers	回転速度 (min ⁻¹) revolution/min						
	400	800	1,200	1,500	1,800	2,500	3,000
ASG1S 70B - 1012	1.38	2.77	4.01	4.90	5.79	7.66	8.84
ASG1S 80B - 1012	1.62	3.21	4.62	5.67	6.67	8.71	10.04
ASG1S 100B - 1012	2.09	4.05	5.84	7.13	8.27	10.70	12.40
ASG1S 120B - 1015	2.56	4.87	7.02	8.45	9.73	12.67	14.49
ASG1.5S 40B - 1515	2.36	4.72	6.95	8.49	10.02	13.45	15.60
ASG1.5S 50B - 1520	3.12	6.22	8.98	10.99	12.95	17.03	19.60
ASG1.5S 60B - 1520	3.89	7.64	11.01	13.47	15.76	20.38	23.64
ASG1.5S 80B - 1520	5.46	10.40	15.01	18.04	20.79	27.06	30.94
ASG2S 30B - 2015	3.84	7.67	11.29	13.80	16.27	21.85	23.34
ASG2S 40B - 2020	5.60	11.10	15.99	19.59	23.06	30.11	34.71
ASG2S 50B - 2020	7.40	14.37	20.72	25.28	29.32	37.96	43.98
ASG2S 60B - 2025	9.23	17.58	25.36	30.49	35.13	45.73	52.29

The above numerical values are equivalent to JGMA formulas as reference only.

動力の換算式は P26 をご参照ください。Please refer to the conversion fomulas of power on page P26.

歯面強さ (kW)

Allowable transfer capability table (kW) Surface Durability

	回転速度 (min ⁻¹) revolution/min						
	400	800	1,200	1,500	1,800	2,500	3,000
	0.86	1.77	2.62	3.25	3.87	5.23	6.10
	1.14	2.33	3.43	4.25	5.06	6.74	7.85
	1.82	3.64	5.37	6.64	7.79	10.28	12.04
	2.66	5.24	7.73	9.42	10.98	14.57	16.82
	0.95	1.93	2.90	3.58	4.26	5.84	6.84
	1.50	3.07	4.52	5.60	6.67	8.95	10.41
	2.19	4.43	6.52	8.08	9.55	12.60	14.77
	3.99	7.86	11.60	14.14	16.47	21.85	23.23
	1.26	2.58	3.86	4.77	5.69	7.78	9.12
	2.29	4.66	6.85	8.51	10.12	13.48	15.70
	3.64	7.29	10.74	13.28	15.57	20.56	24.07
	5.32	10.48	15.47	18.85	21.95	29.13	33.64



齒研平齒車

Ground Spur Gears

商品記号の読み方 Reference of Catalogue Number

SG 50 S 50 B - 80 08
 SG 80 S 100 B * 08 20
 SG 2 S 40 B - 20 20
 SGE 3 S 80 B - 30 22

歯車の種類 Kind of Gear	モジュールの大きさ Module	材質 Material	歯数 Number of Teeth	形状 Type	穴仕上 Bores Processed	歯幅 Face Width	穴径 Bore Diameter
SG : 齒研平齒車 (JIS N5 級) GROUND SPUR GEARS (JIS class 5) SGE : 齒研平齒車 (JIS N7 級) GROUND SPUR GEARS (JIS class 7)	m : 0.5 0.8 1.0 1.5 2.0 2.5 3.0 Expressed the unit of module's size. Module 0.5 and 0.8 as multiple of 100. Example m0.5 → 50 m0.8 → 80	SG : S : SCM435、440 齒部高周波焼入 HRC49 ~ 55 Material : Chromium Molybdenum Steel, complete with high frequency Induction Hardening. (HRC49 to 55). SGE : S : S45C 齒部高周波焼入 HRC47 ~ 53 Material : carbon steel Complete with high frequency Induction Hardening. (HRC47 to 53)	Z : 14 ~ 120	L : 両軸付き 研削仕上 with Solid shaft on both side. B : 片ハブ付き with Hub on one side.	SG : 【-】: 研削仕上 Ground bore, without threaded hole / without Set Screw. 【*】: 研削仕上 2 箇所止めねじ付き with two threaded holes / without Set Screw. SGE : 【-】: 旋削仕上 Without Threaded hole / without Set Screw	単位 : ミリメートル Dimension : millimeter	単位 : ミリメートル Dimension : millimeter

半導体製造装置などメカトロ分野並びに精密機器、工作機械の精密な動きを必要とするところに、“使いやすい精密齒車”です。

KG GROUND SPUR GEARS are useful for Mechatronic fields and Semiconductor manufacturing equipment, which require steady and accurate motion for Machine Tools and other precision instruments.

歯研平歯車

GROUND SPUR GEARS

モジュール **0.5** 圧力角 20° (並歯)
 MODULE 20° PRESSURE ANGLE FULL DEPTH TOOTH

歯部高周波焼き入れ HRC49 ~ 55
 JIS B 1702-1 (ISO) 5 級
 System of accuracy: JIS B1702-1(ISO) class 5



New **ねじを2箇所 (120°配) にしました。**
締結力が1.6倍になりました。
 New item with two threaded holes (120°)
 Tightening power increased by 1.6 times.

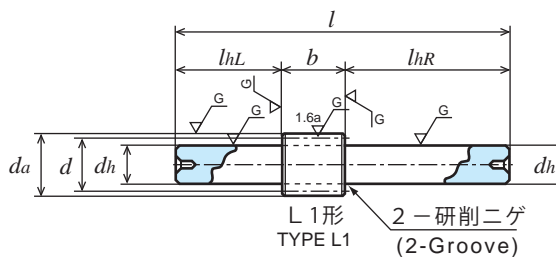

SCM435、440 クロムモリブデン鋼 (JIS G 4053)

Material : Chromium Molybdenum Steel (ISO 34CrMo4, 42CrMo4)

単位 : mm
 Dimensions : mm

商品記号 Catalogue Number	歯数 Number of Teeth z	基準円直径 Reference Diameter d	歯先円直径 Tip Diameter da	形 Type	歯幅 Face Width b	穴径 Bore Diameter da(H7)	ハブ外径 Hub Diameter dh	ハブ長さ Hub Projection lh	全長 Overall Length l	ねじ Set Screw		キリ Tap Guide dr	重量 Weight W(g)
										M	ls		
SG50S 20L - 0806	20	φ10	φ11	L1	8	-	φ 6 (h7)	L22 R50	80	-	-	-	20.8
SG50S 22L - 0808	22	φ11	φ12	L1	8	-	φ 8 (h7)	L22 R50	80	-	-	-	34.2
SG50S 24L - 0810	24	φ12	φ13	L1	8	-	φ10 (h7)	L22 R50	80	-	-	-	51.1
SG50S 25L - 0810	25	φ12.5	φ13.5	L1	8	-	φ10 (h7)	L22 R50	80	-	-	-	51.7
SG50S 26L - 0810	26	φ13	φ14	L1	8	-	φ10 (h7)	L22 R50	80	-	-	-	52.4
SG50S 28B - 0805	28	φ14	φ15	B1	8	φ5	φ10	8	16	-	-	-	12.1
SG50S 30B - 0805	30	φ15	φ16	B1	8	φ5	φ12	8	16	-	-	-	15.6
SG50S 30B - 0806	30	φ15	φ16	B1	8	φ6	φ12	8	16	-	-	-	14.5
SG50S 30B * 0806	30	φ15	φ16	B1	8	φ6	φ12	8	16	2-M3	4	-	14.4
SG50S 32B - 0805	32	φ16	φ17	B1	8	φ5	φ12	8	16	-	-	-	17.2
SG50S 32B - 0806	32	φ16	φ17	B1	8	φ6	φ12	8	16	-	-	-	16.1

セットスクリューはついておりません。 [*] : Gear with Two Thread holes / without Set Screw.
 Gear tooth surface completed with induction hardening, Hardness HRC49 to 55.

許容伝達動力表 曲げ強さ (W)

Allowable transfer capability table (W) Bending Strength

歯数 z	歯幅 b	回転速度 (min ⁻¹) revolution/min						
		400	800	1,200	1,500	1,800	2,500	3,000
20	8	108.04	216.08	324.12	405.15	486.18	675.25	810.30
22	8	124.31	248.63	372.94	466.17	559.41	776.95	932.34
24	8	140.85	281.70	422.54	528.18	633.81	880.30	1,056.36
25	8	149.23	298.46	447.69	559.61	671.53	932.68	1,119.22
26	8	157.67	315.34	473.01	591.26	709.51	985.43	1,182.52
28	8	174.71	349.41	524.12	655.15	786.18	1,091.91	1,310.30
30	8	191.83	383.66	575.50	719.37	863.24	1,198.95	1,438.74
32	8	209.19	418.38	627.57	784.46	941.35	1,307.43	1,568.92

歯面強さ (W)

Allowable transfer capability table (W) Surface Durability

回転速度 (min ⁻¹) revolution/min						
400	800	1,200	1,500	1,800	2,500	3,000
25.17	50.59	76.25	95.65	115.17	161.15	194.36
30.61	61.55	92.81	116.45	140.25	196.36	236.91
36.59	73.62	111.05	139.38	167.91	235.22	283.88
39.79	80.07	120.81	151.65	182.72	256.03	309.05
43.13	86.81	131.00	164.46	198.18	277.76	335.34
50.22	101.12	152.66	191.71	231.06	324.02	391.30
57.86	116.57	176.05	221.13	266.60	374.03	451.82
66.06	133.15	201.17	252.76	304.79	427.81	516.93

The above numerical values are equivalent to JGMA formulas as reference only.
 動力の換算式は P26 をご参照ください。 Please refer to the conversion fomulas of power on page P26.

歯研平歯車

GROUND SPUR GEARS

モジュール **0.5** 圧力角 20° (並歯)
 MODULE 20° PRESSURE ANGLE FULL DEPTH TOOTH

歯部高周波焼き入れ HRC49 ~ 55
 JIS B 1702-1 (ISO) 5 級
 System of accuracy: JIS B1702-1(ISO) class 5



御注文には必ず “フルネームで商品記号” を明記してください。
 Please refer to the catalogue reference while ordering.

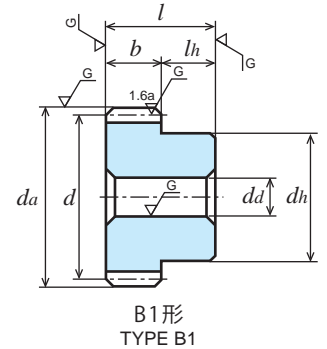
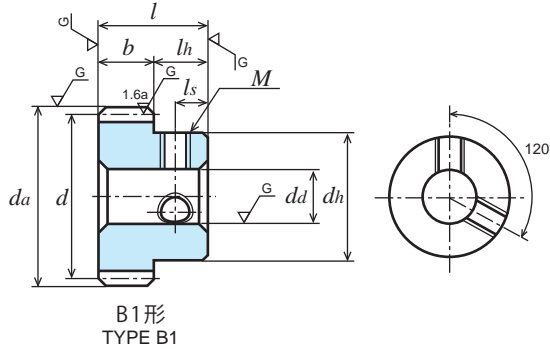

SCM435、440 クロムモリブデン鋼 (JIS G 4053)

Material : Chromium Molybdenum Steel (ISO 34CrMo4, 42CrMo4)

単位 : mm
 Dimensions : mm

商品記号 Catalogue Number	歯数 Number of Teeth z	基準円直径 Reference Diameter d	歯先円直径 Tip Diameter da	形 Type	歯幅 Face Width b	穴径 Bore Diameter da(H7)	ハブ外径 Hub Diameter dh	ハブ長さ Hub Projection lh	全長 Overall Length l	ねじ Set Screw		キリ Tap Guide dr	重量 Weight W(g)
										M	ls		
SG50S 35B - 0805	35	φ17.5	φ18.5	B1	8	φ5	φ14	8	16	-	-	-	22.2
SG50S 36B - 0806	36	φ18	φ19	B1	8	φ6	φ16	8	16	-	-	-	24.9
SG50S 36B - 0808	36	φ18	φ19	B1	8	φ8	φ16	8	16	-	-	-	22.1
SG50S 40B - 0806	40	φ20	φ21	B1	8	φ6	φ16	8	16	-	-	-	28.6
SG50S 40B - 0808	40	φ20	φ21	B1	8	φ8	φ16	8	16	-	-	-	25.9
SG50S 40B * 0808	40	φ20	φ21	B1	8	φ8	φ16	8	16	2-M4	4	-	25.5
SG50S 45B - 0808	45	φ22.5	φ23.5	B1	8	φ8	φ16	8	16	-	-	-	31.1
SG50S 48B - 0808	48	φ24	φ25	B1	8	φ8	φ20	8	16	-	-	-	34.5

セットスクリューはついておりません。 [*] : Gear with Two Thread holes / without Set Screw.
 Gear tooth surface completed with induction hardening, Hardness HRC49 to 55.

許容伝達動力表 曲げ強さ (W)

Allowable transfer capability table (W) Bending Strength

歯数 z	歯幅 b	回転速度 (min ⁻¹) revolution/min						
		400	800	1,200	1,500	1,800	2,500	3,000
35	8	235.49	470.97	706.46	883.07	1,059.69	1,471.79	1,766.14
36	8	244.32	488.63	732.95	916.18	1,099.42	1,526.97	1,832.36
40	8	279.89	559.78	839.67	1,049.58	1,259.50	1,749.30	2,091.76
42	8	297.82	595.64	893.46	1,116.83	1,340.19	1,861.38	2,217.10
44	8	315.62	631.24	946.87	1,183.58	1,420.30	1,972.64	2,340.50
45	8	324.64	649.28	973.91	1,217.39	1,460.87	2,028.99	2,402.69
48	8	351.79	703.58	1,055.38	1,319.22	1,583.07	2,190.95	2,588.62

The above numerical values are equivalent to JGMA formulas as reference only.

動力の換算式は P26 をご参照ください。 Please refer to the conversion formulas of power on page P26.

歯面強さ (W)

Allowable transfer capability table (W) Surface Durability

回転速度 (min ⁻¹) revolution/min							
400	800	1,200	1,500	1,800	2,500	3,000	
79.42	160.18	242.14	304.34	367.11	515.63	623.27	
84.16	169.76	256.68	322.65	389.24	546.82	661.05	
104.51	211.00	319.25	401.49	484.56	681.25	821.03	
115.54	233.37	353.22	444.30	536.33	754.32	905.72	
127.15	256.91	388.98	489.39	590.86	831.31	994.49	
133.17	269.12	407.53	512.79	619.17	871.29	1,040.39	
152.08	307.52	465.92	586.43	708.29	993.65	1,184.13	

目次
CONTENTS

インフォメーション
INFORMATION

ギヤボックス
GEAR BOXES

ノーバックラッシュギヤ
ANTI BACKLASH SPUR GEARS

歯研平歯車
GROUND SPUR GEARS

平歯車
SPUR GEARS

内歯車
INTERNAL GEARS

歯研ラック
GROUND RACKS

ラック
RACKS

へリカル・スプロケットギヤ
HELICAL GEARS AND SCREW GEARS

ウォーム・ウォームギヤ
WORMS AND WORM WHEELS

かさ歯車
BEVEL GEARS

スプロケット
SPROCKETS

技術資料
REFERENCE DATA

歯研平歯車

GROUND SPUR GEARS

モジュール **0.5** 圧力角 20° (並歯)
 MODULE 20° PRESSURE ANGLE FULL DEPTH TOOTH

歯部高周波焼き入れ HRC49 ~ 55
 JIS B 1702-1 (ISO) 5 級
 System of accuracy: JIS B1702-1(ISO) class 5



New **ねじを2箇所 (120° 配) にしました。**
締結力が 1.6 倍になりました。
 New item with two threaded holes (120°)
 Tightening power increased by 1.6 times.

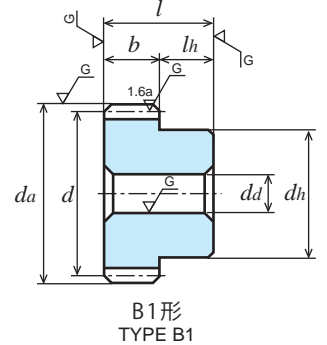
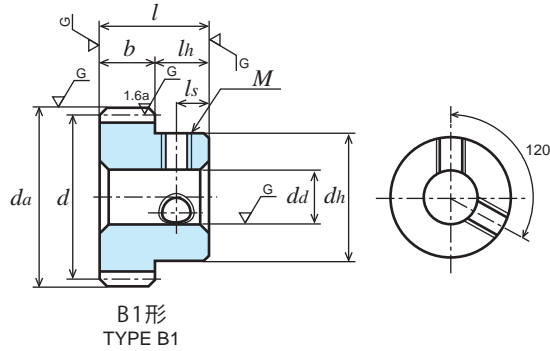

SCM435、440 クロムモリブデン鋼 (JIS G 4053)

Material : Chromium Molybdenum Steel (ISO 34CrMo4, 42CrMo4)

単位 : mm
 Dimensions : mm

商品記号 Catalogue Number	歯数 Number of Teeth z	基準円直径 Reference Diameter d	歯先円直径 Tip Diameter da	形 Type	歯幅 Face Width b	穴径 Bore Diameter da(H7)	ハブ外径 Hub Diameter dh	ハブ長さ Hub Projection lh	全長 Overall Length l	ねじ Set Screw		キリ Tap Guide dr	重量 Weight W(g)
										M	ls		
SG50S 50B - 0808	50	φ25	φ26	B1	8	φ 8	φ20	8	16	-	-	-	43.9
SG50S 50B - 0810	50	φ25	φ26	B1	8	φ10	φ20	8	16	-	-	-	40.4
SG50S 50B * 0810	50	φ25	φ26	B1	8	φ10	φ20	8	16	2-M4	4	-	40.0
SG50S 54B - 0808	54	φ27	φ28	B1	8	φ 8	φ20	8	16	-	-	-	49.0
SG50S 55B - 0808	55	φ27.5	φ28.5	B1	8	φ 8	φ20	8	16	-	-	-	50.4
SG50S 56B - 0808	56	φ28	φ29	B1	8	φ 8	φ20	8	16	-	-	-	51.7
SG50S 60B - 0808	60	φ30	φ31	B1	8	φ 8	φ22	8	16	-	-	-	61.5
SG50S 60B - 0810	60	φ30	φ31	B1	8	φ10	φ22	8	16	-	-	-	58.0
SG50S 60B * 0810	60	φ30	φ31	B1	8	φ10	φ22	8	16	2-M4	4	-	57.6
SG50S 64B - 0808	64	φ32	φ33	B1	8	φ 8	φ22	8	16	-	-	-	67.6
SG50S 70B - 0808	70	φ35	φ36	B1	8	φ 8	φ22	8	16	-	-	-	77.4

セットスクリューはついておりません。 [*] : Gear with Two Thread holes / without Set Screw.
 Gear tooth surface completed with induction hardening, Hardness HRC49 to 55.

許容伝達動力表 曲げ強さ (W)

Allowable transfer capability table (W) Bending Strength

歯数 z	歯幅 b	回転速度 (min ⁻¹) revolution/min						
		400	800	1,200	1,500	1,800	2,500	3,000
50	8	369.97	739.94	1,109.91	1,387.38	1,664.86	2,296.66	2,711.92
52	8	388.21	776.41	1,164.62	1,455.78	1,746.93	2,402.07	2,834.73
54	8	406.49	812.98	1,219.47	1,524.34	1,829.21	2,507.08	2,956.93
55	8	415.65	831.31	1,246.96	1,558.70	1,870.44	2,559.46	3,017.83
56	8	424.83	849.65	1,274.47	1,593.09	1,911.71	2,611.72	3,078.57
60	8	461.62	923.25	1,384.87	1,731.08	2,077.30	2,819.79	3,320.04
64	8	498.57	997.13	1,495.70	1,869.62	2,242.66	3,023.11	3,559.67
70	8	554.23	1,108.46	1,662.69	2,078.37	2,475.56	3,332.20	3,927.74

歯面強さ (W)

Allowable transfer capability table (W) Surface Durability

回転速度 (min ⁻¹) revolution/min							
400	800	1,200	1,500	1,800	2,500	3,000	
165.41	334.61	507.12	638.42	771.20	1,078.73	1,284.96	
179.32	362.89	550.15	692.72	836.93	1,167.23	1,389.78	
193.81	392.37	595.01	749.36	905.50	1,259.13	1,498.55	
201.28	407.56	618.14	778.55	940.85	1,306.36	1,554.41	
208.89	423.05	641.73	808.33	976.92	1,354.43	1,611.25	
240.80	488.02	740.72	933.35	1,128.33	1,555.13	1,848.36	
275.06	557.86	847.18	1,067.84	1,290.76	1,769.21	2,101.33	
330.89	671.79	1,020.99	1,287.52	1,545.96	2,115.13	2,518.03	

The above numerical values are equivalent to JGMA formulas as reference only.
 動力の換算式は P26 をご参照ください。 Please refer to the conversion fomulas of power on page P26.

歯研平歯車

GROUND SPUR GEARS

モジュール **0.5** 圧力角 20° (並歯)
 MODULE 20° PRESSURE ANGLE FULL DEPTH TOOTH

歯部高周波焼き入れ HRC49 ~ 55
 JIS B 1702-1 (ISO) 5 級
 System of accuracy: JIS B1702-1(ISO) class 5



御注文には必ず “フルネームで商品記号” を明記してください。
 Please refer to the catalogue reference while ordering.

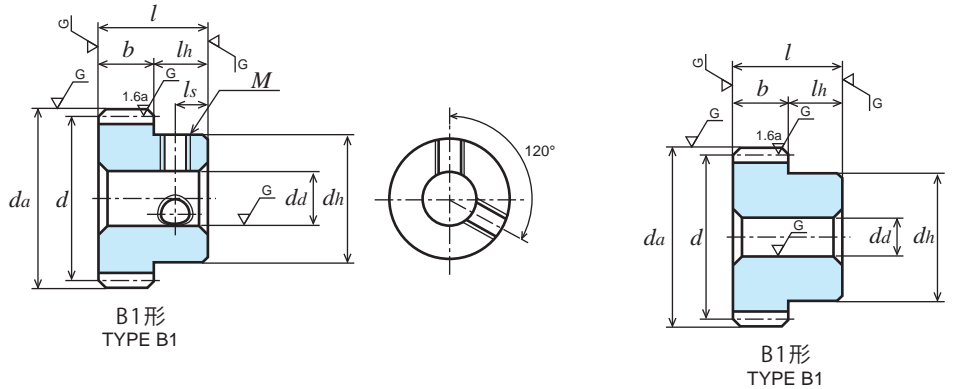

SCM435、440 クロムモリブデン鋼 (JIS G 4053)

Material : Chromium Molybdenum Steel (ISO 34CrMo4, 42CrMo4)

単位 : mm
 Dimensions : mm

商品記号 Catalogue Number	歯数 Number of Teeth z	基準円直径 Reference Diameter d	歯先円直径 Tip Diameter da	形 Type	歯幅 Face Width b	穴径 Bore Diameter da(H7)	ハブ外径 Hub Diameter dh	ハブ長さ Hub Projection lh	全長 Overall Length l	ねじ Set Screw		キリ Tap Guide dr	重量 Weight W(g)
										M	ls		
SG50S 72B - 0808	72	φ36	φ37	B1	8	φ 8	φ25	8	16	-	-	-	87.8
SG50S 75B - 0808	75	φ37.5	φ38.5	B1	8	φ 8	φ25	8	16	-	-	-	93.2
SG50S 80B - 0808	80	φ40	φ41	B1	8	φ 8	φ25	8	16	-	-	-	102.7
SG50S 80B - 0810	80	φ40	φ41	B1	8	φ10	φ25	8	16	-	-	-	99.2
SG50S 80B - 0812	80	φ40	φ41	B1	8	φ12	φ25	8	16	-	-	-	94.9
SG50S 80B * 0812	80	φ40	φ41	B1	8	φ12	φ25	8	16	2-M5	4	-	94.1
SG50S 90B - 0810	90	φ45	φ46	B1	8	φ10	φ30	8	16	-	-	-	133.5
SG50S 96B - 0810	96	φ48	φ49	B1	8	φ10	φ30	8	16	-	-	-	147.1
SG50S 100B - 0810	100	φ50	φ51	B1	8	φ10	φ30	8	16	-	-	-	156.7
SG50S 100B - 0812	100	φ50	φ51	B1	8	φ12	φ30	8	16	-	-	-	152.4
SG50S 100B * 0812	100	φ50	φ51	B1	8	φ12	φ30	8	16	2-M5	4	-	151.5
SG50S 108B - 0810	108	φ54	φ55	B1	8	φ10	φ35	8	16	-	-	-	193.0
SG50S 112B - 0810	112	φ56	φ57	B1	8	φ10	φ35	8	16	-	-	-	203.8
SG50S 120B - 0810	120	φ60	φ61	B1	8	φ10	φ35	8	16	-	-	-	226.6

セットスクリューはついておりません。 [*]: Gear with Two Thread holes / without Set Screw.
 Gear tooth surface completed with induction hardening, Hardness HRC49 to 55.

許容伝達動力表 曲げ強さ (W)

Allowable transfer capability table (W) Bending Strength

歯数 z	歯幅 b	回転速度 (min ⁻¹) revolution/min						
		400	800	1,200	1,500	1,800	2,500	3,000
72	8	572.84	1,145.69	1,178.53	2,148.17	2,552.72	3,433.30	4,049.63
75	8	600.84	1,201.61	1,802.41	2,253.02	2,667.98	3,584.01	4,231.63
80	8	647.54	1,295.08	1,942.62	2,419.70	2,858.90	3,839.99	4,532.93
90	8	740.43	1,480.87	2,221.30	2,740.03	3,231.68	4,345.90	5,120.65
96	8	796.77	1,593.54	2,389.35	2,931.46	3,453.87	4,647.97	5,470.63
100	8	834.38	1,668.76	2,494.32	3,058.06	3,600.58	4,847.65	5,701.55
108	8	909.75	1,819.50	2,702.70	3,308.89	3,893.39	5,243.00	6,135.59
112	8	947.51	1,895.02	2,806.16	3,433.16	4,042.91	5,438.74	6,345.45
120	8	1,023.12	2,046.24	3,011.40	3,679.20	4,339.67	5,826.04	6,757.02

The above numerical values are equivalent to JGMA formulas as reference only.

動力の換算式は P26 をご参照ください。Please refer to the conversion fomulas of power on page P26.

歯面強さ (W)

Allowable transfer capability table (W) Surface Durability

回転速度 (min ⁻¹) revolution/min						
400	800	1,200	1,500	1,800	2,500	3,000
350.69	712.23	1,082.72	1,365.57	1,636.03	2,236.98	2,665.11
381.51	775.21	1,178.89	1,487.18	1,775.81	2,425.83	2,893.33
435.87	886.40	1,348.78	1,696.04	2,021.16	2,761.77	3,293.88
555.93	1,132.30	1,724.83	2,149.18	2,557.83	3,501.66	4,169.72
635.27	1,295.04	1,973.12	2,446.11	2,908.90	3,986.43	4,742.36
691.23	1,409.92	2,142.24	2,654.41	3,154.91	4,326.43	5,143.47
810.54	1,655.11	2,500.92	3,095.63	3,677.90	5,046.42	5,969.89
873.91	1,785.46	2,690.44	3,328.44	3,958.21	5,426.21	6,400.03
1,008.14	2,061.81	3,089.65	3,818.25	4,549.00	6,224.91	7,298.89

目次 CONTENTS
 インフォメーション INFORMATION
 ギヤボックス GEAR BOXES
 ノーバックラッシュギヤ ANTI BACKLASH SPUR GEARS
 歯研平歯車 GROUND SPUR GEARS
 平歯車 SPUR GEARS
 内歯車 INTERNAL GEARS
 歯研ラック GROUND RACKS
 ラック RACKS
 へリカル・スクリューギヤ HELICAL GEARS AND SCREW GEARS
 マーモット・マニマニギヤ WORMS AND WORM WHEELS
 かみ歯車 BEVEL GEARS
 スプロケット SPROCKETS
 技術資料 REFERENCE DATA

歯研平歯車

GROUND SPUR GEARS

モジュール **0.8** 圧力角 20° (並歯)
 MODULE 20° PRESSURE ANGLE FULL DEPTH TOOTH

歯部高周波焼き入れ Hrc49 ~ 55
 JIS B 1702-1 (ISO) 5 級
 System of accuracy: JIS B1702-1(ISO) class 5



New **ねじを2箇所 (120°配) にしました。**
締結力が1.6倍になりました。
 New item with two threaded holes (120°)
 Tightening power increased by 1.6 times.

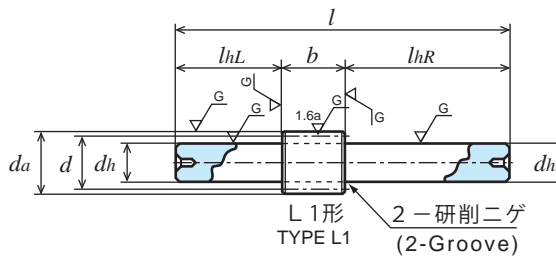

SCM435、440 クロムモリブデン鋼 (JIS G 4053)

Material : Chromium Molybdenum Steel (ISO 34CrMo4, 42CrMo4)

単位 : mm
 Dimensions : mm

商品記号 Catalogue Number	歯数 Number of Teeth z	基準円直径 Reference Diameter d	歯先円直径 Tip Diameter da	形 Type	歯幅 Face Width b	穴径 Bore Diameter da(H7)	ハブ外径 Hub Diameter dh	ハブ長さ Hub Projection lh	全長 Overall Length l	ねじ Set Screw		キリ Tap Guide dr	重量 Weight W(g)
										M	ls		
SG80S 15L - 0806	15	φ12	φ13.6	L1	8	-	φ 6 (h7)	L22 R60	90	-	-	-	25.1
SG80S 16L - 0806	16	φ12.8	φ14.4	L1	8	-	φ 6 (h7)	L22 R60	90	-	-	-	26.1
SG80S 18L - 0808	18	φ14.4	φ16	L1	8	-	φ 8 (h7)	L22 R60	90	-	-	-	42.3
SG80S 20L - 0810	20	φ16	φ17.6	L1	8	-	φ10 (h7)	L22 R60	90	-	-	-	62.7
SG80S 22B - 0806	22	φ17.6	φ19.2	B1	8	φ 6	φ14	10	18	-	-	-	23.2
SG80S 24L - 0810	24	φ19.2	φ20.8	L1	8	-	φ10 (h7)	L22 R60	90	-	-	-	68.3
SG80S 24B - 0806	24	φ19.2	φ20.8	B1	8	φ 6	φ16	10	18	-	-	-	29.8
SG80S 25L - 0810	25	φ20	φ21.6	L1	8	-	φ10 (h7)	L22 R60	90	-	-	-	69.8
SG80S 25B - 0806	25	φ20	φ21.6	B1	8	φ 6	φ16	10	18	-	-	-	31.3
SG80S 28B - 0808	28	φ22.4	φ24	B1	8	φ 8	φ18	10	18	-	-	-	37.4
SG80S 30B - 0810	30	φ24	φ25.6	B1	8	φ10	φ20	10	18	-	-	-	41.7
SG80S 30B * 0810	30	φ24	φ25.6	B1	8	φ10	φ20	10	18	2-M4	5	-	41.3

セットスクリューはついておりません。 [*] : Gear with Two Thread holes / without Set Screw.
 Gear tooth surface completed with induction hardening, Hardness HRC49 to 55.

許容伝達動力表 曲げ強さ (kW)

Allowable transfer capability table (kW) Bending Strength

歯数 z	歯幅 b	回転速度 (min ⁻¹) revolution/min						
		400	800	1,200	1,500	1,800	2,500	3,000
15	8	0.17	0.35	0.52	0.66	0.79	1.10	1.32
16	8	0.19	0.39	0.58	0.73	0.88	1.22	1.46
18	8	0.23	0.47	0.70	0.88	1.06	1.47	1.76
20	8	0.27	0.55	0.82	1.03	1.24	1.72	2.07
22	8	0.31	0.63	0.95	1.19	1.43	1.98	2.38
24	8	0.36	0.72	1.08	1.35	1.62	2.25	2.70
25	8	0.38	0.76	1.14	1.43	1.71	2.38	2.85
28	8	0.44	0.89	1.34	1.67	2.01	2.79	3.31
30	8	0.49	0.98	1.47	1.84	2.20	3.05	3.61

歯面強さ (kW)

Allowable transfer capability table (kW) Surface Durability

回転速度 (min ⁻¹) revolution/min						
400	800	1,200	1,500	1,800	2,500	3,000
0.036	0.075	0.11	0.13	0.16	0.23	0.28
0.041	0.084	0.12	0.15	0.19	0.26	0.32
0.053	0.107	0.16	0.20	0.24	0.34	0.41
0.066	0.133	0.20	0.25	0.30	0.42	0.51
0.080	0.162	0.24	0.30	0.37	0.52	0.63
0.096	0.193	0.29	0.36	0.44	0.62	0.75
0.104	0.211	0.31	0.40	0.48	0.68	0.82
0.131	0.266	0.40	0.50	0.61	0.86	1.03
0.15	0.30	0.46	0.58	0.70	0.99	1.18

The above numerical values are equivalent to JGMA formulas as reference only.

動力の換算式は P26 をご参照ください。Please refer to the conversion fomulas of power on page P26.

歯研平歯車

GROUND SPUR GEARS

モジュール **0.8** 圧力角 20° (並歯)
 MODULE 20° PRESSURE ANGLE FULL DEPTH TOOTH

歯部高周波焼き入れ HRC49 ~ 55
 JIS B 1702-1 (ISO) 5 級
 System of accuracy: JIS B1702-1(ISO) class 5

御注文には必ず “フルネームで商品記号” を明記してください。
 Please refer to the catalogue reference while ordering.

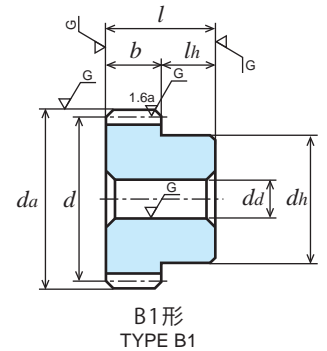
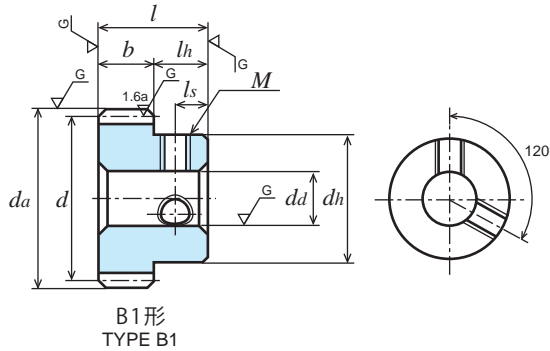

SCM435、440 クロムモリブデン鋼 (JIS G 4053)

Material : Chromium Molybdenum Steel (ISO 34CrMo4, 42CrMo4)

単位 : mm
 Dimensions : mm

商品記号 Catalogue Number	歯数 Number of Teeth z	基準円直径 Reference Diameter d	歯先円直径 Tip Diameter da	形 Type	歯幅 Face Width b	穴径 Bore Diameter da(H7)	ハブ外径 Hub Diameter dh	ハブ長さ Hub Projection lh	全長 Overall Length l	ねじ Set Screw		キリ Tap Guide dr	重量 Weight W(g)
										M	ls		
SG80S 32B - 0810	32	φ25.6	φ27.2	B1	8	φ10	φ20	10	18	-	-	-	45.6
SG80S 35B - 0810	35	φ28	φ29.6	B1	8	φ10	φ20	10	18	-	-	-	51.9
SG80S 36B - 0810	36	φ28.8	φ30.4	B1	8	φ10	φ20	10	18	-	-	-	54.1
SG80S 40B - 0810	40	φ32	φ33.6	B1	8	φ10	φ25	10	18	-	-	-	77.4
SG80S 40B * 0812	40	φ32	φ33.6	B1	8	φ12	φ25	10	18	2-M5	5	-	71.5
SG80S 45B - 0810	45	φ36	φ37.6	B1	8	φ10	φ25	10	18	-	-	-	90.8
SG80S 48B - 0810	48	φ38.4	φ40	B1	8	φ10	φ25	10	18	-	-	-	99.5
SG80S 50B - 0810	50	φ40	φ41.6	B1	8	φ10	φ25	10	18	-	-	-	105.6
SG80S 50B * 0812	50	φ40	φ41.6	B1	8	φ12	φ25	10	18	2-M5	5	-	100.0
SG80S 54B - 0810	54	φ43.2	φ44.8	B1	8	φ10	φ25	10	18	-	-	-	118.7
SG80S 55B - 0810	55	φ44	φ45.6	B1	8	φ10	φ25	10	18	-	-	-	122.1
SG80S 56B - 0810	56	φ44.8	φ46.4	B1	8	φ10	φ25	10	18	-	-	-	125.6
SG80S 60B - 0810	60	φ48	φ49.6	B1	8	φ10	φ25	10	18	-	-	-	140.1
SG80S 60B * 0812	60	φ48	φ49.6	B1	8	φ12	φ25	10	18	2-M5	5	-	134.8

セットスクリューはついておりません。 [*] : Gear with Two Thread holes / without Set Screw.
 Gear tooth surface completed with induction hardening, Hardness HRC49 to 55.

許容伝達動力表 曲げ強さ (kW)

Allowable transfer capability table (kW) Bending Strength

歯数 z	歯幅 b	回転速度 (min ⁻¹) revolution/min						
		400	800	1,200	1,500	1,800	2,500	3,000
32	8	0.53	1.07	1.60	2.00	2.40	3.31	3.91
35	8	0.60	1.20	1.80	2.26	2.71	3.70	4.36
36	8	0.62	1.25	1.87	2.34	2.81	3.83	4.51
40	8	0.71	1.43	2.14	2.68	3.21	4.34	5.10
45	8	0.82	1.65	2.48	3.11	3.69	4.97	5.86
48	8	0.90	1.80	2.70	3.37	3.99	5.35	6.32
50	8	0.94	1.89	2.84	3.53	4.18	5.61	6.63
54	8	1.04	2.08	3.12	3.86	4.56	6.13	7.22
55	8	1.06	2.12	3.19	3.94	4.65	6.25	7.37
56	8	1.08	2.17	3.29	4.02	4.74	6.38	7.52
60	8	1.18	2.36	3.54	4.34	5.12	6.89	8.11

The above numerical values are equivalent to JGMA formulas as reference only.

動力の換算式は P26 をご参照ください。 Please refer to the conversion fomulas of power on page P26.

歯面強さ (kW)

Allowable transfer capability table (kW) Surface Durability

回転速度 (min ⁻¹) revolution/min							
400	800	1,200	1,500	1,800	2,500	3,000	
0.17	0.35	0.53	0.67	0.81	1.13	1.34	
0.20	0.42	0.64	0.80	0.97	1.35	1.61	
0.22	0.44	0.68	0.85	1.03	1.43	1.70	
0.27	0.55	0.84	1.06	1.29	1.76	2.10	
0.35	0.71	1.08	1.36	1.63	2.23	2.66	
0.40	0.81	1.23	1.56	1.86	2.54	3.03	
0.43	0.88	1.34	1.69	2.02	2.76	3.29	
0.51	1.04	1.58	1.98	2.35	3.22	3.84	
0.53	1.08	1.64	2.05	2.44	3.34	3.98	
0.55	1.12	1.70	2.13	2.53	3.47	4.13	
0.63	1.29	1.97	2.44	2.90	3.98	4.74	

目次 CONTENTS
 インフォメーション INFORMATION
 ギヤボックス GEAR BOXES
 ノーマルバックラッシュギヤ N/A BACKLASH SPUR GEARS
 歯研平歯車 GROUND SPUR GEARS
 平歯車 SPUR GEARS
 内歯車 INTERNAL GEARS
 歯研斜歯車 GROUND RACKS
 ラック RACKS
 斜歯車とスクリュー HEICAL GEARS AND SCREW GEARS
 ワームとワームホイール WORMS AND WORM WHEELS
 かみ歯車 BEVEL GEARS
 スプロケット SPROCKETS
 技術仕様書 REFERENCE DATA

歯研平歯車

GROUND SPUR GEARS

モジュール **0.8** 圧力角 20° (並歯)
 MODULE 20° PRESSURE ANGLE FULL DEPTH TOOTH

歯部高周波焼き入れ HRC49 ~ 55
 JIS B 1702-1 (ISO) 5 級
 System of accuracy: JIS B1702-1(ISO) class 5



New **ねじを2箇所 (120° 配) にしました。**
締結力が 1.6 倍になりました。
 New item with two threaded holes (120°)
 Tightening power increased by 1.6 times.

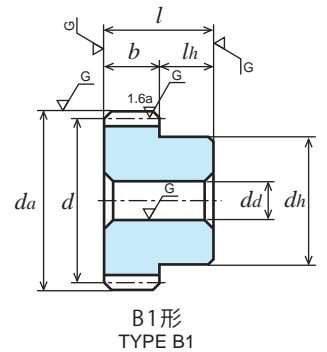
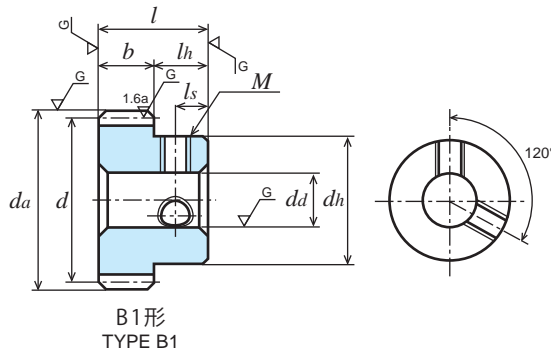

SCM435、440 クロムモリブデン鋼 (JIS G 4053)

Material : Chromium Molybdenum Steel (ISO 34CrMo4, 42CrMo4)

単位 : mm
 Dimensions : mm

商品記号 Catalogue Number	歯数 Number of Teeth z	基準円直径 Reference Diameter d	歯先円直径 Tip Diameter da	形 Type	歯幅 Face Width b	穴径 Bore Diameter da(H7)	ハブ外径 Hub Diameter dh	ハブ長さ Hub Projection lh	全長 Overall Length l	ねじ Set Screw		キリ Tap Guide dr	重量 Weight W(g)
										M	ls		
SG80S 64B - 0812	64	φ51.2	φ52.8	B1	8	φ12	φ30	10	18	-	-	-	167.6
SG80S 70B - 0812	70	φ56	φ57.6	B1	8	φ12	φ30	10	18	-	-	-	192.9
SG80S 72B - 0812	72	φ57.6	φ59.2	B1	8	φ12	φ30	10	18	-	-	-	201.9
SG80S 75B - 0812	75	φ60	φ61.6	B1	8	φ12	φ30	10	18	-	-	-	215.7
SG80S 80B - 0812	80	φ64	φ65.6	B1	8	φ12	φ30	10	18	-	-	-	240.0
SG80S 80B * 0815	80	φ64	φ65.6	B1	8	φ15	φ30	10	18	2-M6	5	-	230.3
SG80S 90B - 0812	90	φ72	φ73.6	B1	8	φ12	φ35	10	18	-	-	-	313.2
SG80S 96B - 0812	96	φ76.8	φ78.4	B1	8	φ12	φ35	10	18	-	-	-	348.2
SG80S 100B - 0812	100	φ80	φ81.6	B1	8	φ12	φ35	10	18	-	-	-	372.8
SG80S 100B * 0820	100	φ80	φ81.6	B1	8	φ20	φ35	10	18	2-M6	5	-	344.9
SG80S 108B - 0812	108	φ86.4	φ88	B1	8	φ12	φ40	10	18	-	-	-	448.0
SG80S 112B - 0812	112	φ89.6	φ91.2	B1	8	φ12	φ40	10	18	-	-	-	475.6
SG80S 120B - 0812	120	φ96	φ97.6	B1	8	φ12	φ40	10	18	-	-	-	533.8
SG80S 120B * 0820	120	φ96	φ97.6	B1	8	φ20	φ40	10	18	2-M6	5	-	506.4

セットスクリューはついておりません。 [*] : Gear with Two Thread holes / without Set Screw.

許容伝達動力表 曲げ強さ (kW)

Allowable transfer capability table (kW) Bending Strength

歯数 z	歯幅 b	回転速度 (min ⁻¹) revolution/min						
		400	800	1,200	1,500	1,800	2,500	3,000
64	8	1.27	2.55	3.80	4.66	5.49	7.39	8.69
70	8	1.42	2.84	4.20	5.14	6.05	8.14	9.50
72	8	1.47	2.93	4.33	5.30	6.24	8.39	9.77
75	8	1.54	3.08	4.53	5.53	6.52	8.76	10.16
80	8	1.66	3.32	4.85	5.92	6.99	9.34	10.80
90	8	1.90	3.79	5.48	6.70	7.90	10.43	12.02
96	8	2.04	4.06	5.85	7.17	8.44	11.07	12.74
100	8	2.14	4.23	6.10	7.48	8.80	11.49	13.25
108	8	2.33	4.59	6.61	8.09	9.50	12.31	14.25
112	8	2.43	4.76	6.86	8.39	9.82	12.71	14.74
120	8	2.62	5.11	7.36	8.99	10.47	13.54	15.70

歯面強さ (kW)

Allowable transfer capability table (kW) Surface Durability

		回転速度 (min ⁻¹) revolution/min						
		400	800	1,200	1,500	1,800	2,500	3,000
64	8	0.72	1.48	2.24	2.78	3.30	4.53	5.38
70	8	0.87	1.79	2.69	3.33	3.96	5.43	6.40
72	8	0.93	1.89	2.85	3.52	4.19	5.74	6.75
75	8	1.01	2.06	3.09	3.82	4.55	6.22	7.30
80	8	1.15	2.36	3.52	4.34	5.18	7.06	8.25
90	8	1.47	3.02	4.45	5.51	6.56	8.83	10.29
96	8	1.68	3.43	5.06	6.27	7.46	9.98	11.61
100	8	1.83	3.73	5.48	6.80	8.09	10.78	12.56
108	8	2.15	4.35	6.40	7.94	9.42	12.45	14.57
112	8	2.32	4.68	6.89	8.54	10.10	13.33	15.62
120	8	2.68	5.37	7.92	9.80	11.53	15.20	17.82

The above numerical values are equivalent to JGMA formulas as reference only.

動力の換算式は P26 をご参照ください。Please refer to the conversion fomulas of power on page P26.

歯研平歯車

GROUND SPUR GEARS

モジュール
MODULE

1

圧力角 20° (並歯)
20° PRESSURE ANGLE FULL DEPTH TOOTH

歯部高周波焼き入れ HRC49 ~ 55
JIS B 1702-1 (ISO) 5 級
System of accuracy: JIS B1702-1(ISO) class 5

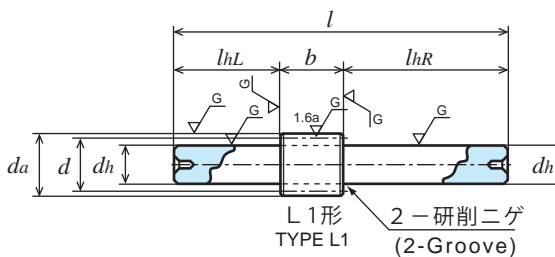

SCM435、440 クロムモリブデン鋼 (JIS G 4053)

Material : Chromium Molybdenum Steel (ISO 34CrMo4, 42CrMo4)

単位 : mm
Dimensions : mm

商品記号 Catalogue Number	歯数 Number of Teeth z	基準円直径 Reference Diameter d	歯先円直径 Tip Diameter da	形 Type	歯幅 Face Width b	穴径 Bore Diameter da(H7)	ハブ外径 Hub Diameter dh	ハブ長さ Hub Projection lh	全長 Overall Length l	ねじ Set Screw		キリ Tap Guide dr	重量 Weight W(g)
										M	ls		
SG1S 14L - 1008	14	φ14	φ16	L1	10	-	φ 8 (h7)	L25 R60	95	-	-	-	45.3
SG1S 15L - 1010	15	φ15	φ17	L1	10	-	φ10 (h7)	L25 R60	95	-	-	-	65.9
SG1S 16L - 1010	16	φ16	φ18	L1	10	-	φ10 (h7)	L25 R60	95	-	-	-	67.8
SG1S 17B - 1006	17	φ17	φ19	B1	10	φ 6	φ12	10	20	-	-	-	22.1
SG1S 18L - 1010	18	φ18	φ20	L1	10	-	φ10 (h7)	L25 R60	95	-	-	-	71.9
SG1S 18B - 1008	18	φ18	φ20	B1	10	φ 8	φ15	10	20	-	-	-	25.8
SG1S 20B - 1008	20	φ20	φ22	B1	10	φ 8	φ16	10	20	-	-	-	32.3
SG1S 20B * 1008	20	φ20	φ22	B1	10	φ 8	φ16	10	20	2-M4	5	-	32.0
SG1S 20B * 1010	20	φ20	φ22	B1	10	φ10	φ16	10	20	2-M4	5	-	27.7
SG1S 21B - 1008	21	φ21	φ23	B1	10	φ 8	φ16	10	20	-	-	-	34.9
SG1S 22B - 1008	22	φ22	φ24	B1	10	φ 8	φ18	10	20	-	-	-	41.7
SG1S 23B - 1008	23	φ23	φ25	B1	10	φ 8	φ18	10	20	-	-	-	44.4

セットスクリューはついておりません。 [*] : Gear with Two Thread holes / without Set Screw.
Gear tooth surface completed with induction hardening, Hardness HRC49 to 55.

許容伝達動力表 曲げ強さ (kW)

Allowable transfer capability table (kW) Bending Strength

歯数 z	歯幅 b	回転速度 (min ⁻¹) revolution/min						
		400	800	1,200	1,500	1,800	2,500	3,000
14	10	0.30	0.61	0.92	1.15	1.38	1.92	2.30
15	10	0.34	0.68	1.03	1.29	1.55	2.15	2.58
16	10	0.38	0.76	1.14	1.43	1.72	2.39	2.87
17	10	0.42	0.84	1.26	1.57	1.89	2.63	3.15
18	10	0.46	0.92	1.38	1.72	2.07	2.87	3.45
20	10	0.54	1.08	1.62	2.02	2.43	3.37	4.03
21	10	0.58	1.16	1.74	2.17	2.61	3.62	4.32
22	10	0.62	1.24	1.86	2.33	2.79	3.88	4.60
23	10	0.66	1.32	1.98	2.48	2.98	4.14	4.89

The above numerical values are equivalent to JGMA formulas as reference only.

動力の換算式は P26 をご参照ください。 Please refer to the conversion fomulas of power on page P26.

歯面強さ (kW)

Allowable transfer capability table (kW) Surface Durability

回転速度 (min ⁻¹) revolution/min						
400	800	1,200	1,500	1,800	2,500	3,000
0.062	0.12	0.19	0.23	0.28	0.40	0.48
0.072	0.14	0.22	0.27	0.33	0.46	0.56
0.082	0.16	0.25	0.31	0.38	0.53	0.64
0.093	0.18	0.28	0.35	0.43	0.60	0.73
0.105	0.21	0.32	0.40	0.48	0.68	0.82
0.130	0.26	0.39	0.50	0.60	0.85	1.02
0.144	0.29	0.44	0.55	0.67	0.94	1.13
0.158	0.32	0.48	0.61	0.73	1.03	1.24
0.174	0.35	0.53	0.67	0.81	1.14	1.35

目次
CONTENTS

インフォメーション
INFORMATION

ギヤボックス
GEAR BOXES

ノーバッキングギヤ
ANTI BACKLASH SPUR GEARS

歯研平歯車
GROUND SPUR GEARS

平歯車
SPUR GEARS

内歯車
INTERNAL GEARS

歯研ラック
GROUND RACKS

ラック
RACKS

斜歯車とスクリュー
HELICAL GEARS AND SCREW GEARS

ワームとワームホイール
WORMS AND WORM WHEELS

かさ歯車
BEVEL GEARS

スプロケット
SPROCKETS

技術資料
REFERENCE DATA

歯研平歯車

GROUND SPUR GEARS

モジュール
MODULE

1

圧力角 20° (並歯)

20° PRESSURE ANGLE FULL DEPTH TOOTH

歯部高周波焼き入れ HRC49 ~ 55
JIS B 1702-1 (ISO) 5 級
System of accuracy: JIS B1702-1(ISO) class 5



New **ねじを2箇所 (120° 配) にしました。**
締結力が 1.6 倍になりました。
New item with two threaded holes (120°)
Tightening power increased by 1.6 times.

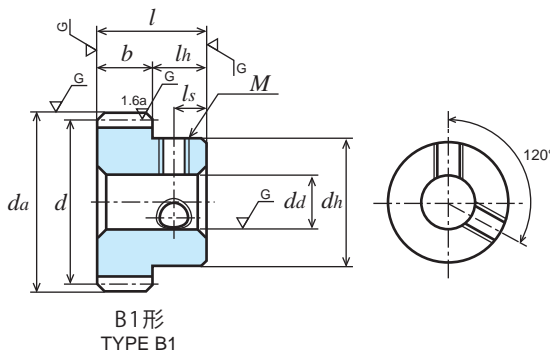

SCM435、440 クロムモリブデン鋼 (JIS G 4053)

Material : Chromium Molybdenum Steel (ISO 34CrMo4, 42CrMo4)

単位 : mm
Dimensions : mm

商品記号 Catalogue Number	歯数 Number of Teeth <i>z</i>	基準円直径 Reference Diameter <i>d</i>	歯先円直径 Tip Diameter <i>da</i>	形 Type	歯幅 Face Width <i>b</i>	穴径 Bore Diameter <i>da</i> (H7)	ハブ外径 Hub Diameter <i>dh</i>	ハブ長さ Hub Projection <i>lh</i>	全長 Overall Length <i>l</i>	ねじ Set Screw		キリ Tap Guide <i>dr</i>	重量 Weight <i>W</i> (g)
										<i>M</i>	<i>ls</i>		
SG1S 24B - 1008	24	φ24	φ26	B1	10	φ 8	φ20	10	20	-	-	-	51.9
SG1S 24B * 1008	24	φ24	φ26	B1	10	φ 8	φ20	10	20	2-M4	5	-	51.4
SG1S 24B * 1010	24	φ24	φ26	B1	10	φ10	φ20	10	20	2-M4	5	-	47.1
SG1S 25B - 1008	25	φ25	φ27	B1	10	φ 8	φ20	10	20	-	-	-	55.0
SG1S 26B - 1008	26	φ26	φ28	B1	10	φ 8	φ20	10	20	-	-	-	58.1
SG1S 27B - 1008	27	φ27	φ29	B1	10	φ 8	φ20	10	20	-	-	-	61.3
SG1S 28B - 1008	28	φ28	φ30	B1	10	φ 8	φ20	10	20	-	-	-	64.7
SG1S 30B - 1010	30	φ30	φ32	B1	10	φ10	φ26	10	20	-	-	-	84.3
SG1S 30B * 1010	30	φ30	φ32	B1	10	φ10	φ26	10	20	2-M4	5	-	83.7
SG1S 30B * 1012	30	φ30	φ32	B1	10	φ12	φ26	10	20	2-M4	5	-	78.5
SG1S 32B - 1010	32	φ32	φ34	B1	10	φ10	φ26	10	20	-	-	-	91.9
SG1S 34B - 1010	34	φ34	φ36	B1	10	φ10	φ26	10	20	-	-	-	100.0

セットスクリューはついておりません。 [*] : Gear with Two Thread holes / without Set Screw.
Gear tooth surface completed with induction hardening, Hardness HRC49 to 55.

許容伝達動力表 曲げ強さ (kW)

Allowable transfer capability table (kW) Bending Strength

歯数 <i>z</i>	歯幅 <i>b</i>	回転速度 (min ⁻¹) revolution/min						
		400	800	1,200	1,500	1,800	2,500	3,000
24	10	0.70	1.40	2.11	2.64	3.16	4.38	5.18
25	10	0.74	1.49	2.23	2.79	3.35	4.63	5.46
26	10	0.78	1.57	2.36	2.95	3.54	4.87	5.75
27	10	0.83	1.66	2.49	3.11	3.73	5.12	6.04
28	10	0.87	1.74	2.62	3.27	3.93	5.37	6.33
30	10	0.95	1.91	2.87	3.59	4.31	5.85	6.89
32	10	1.04	2.09	3.13	3.92	4.70	6.34	7.46
34	10	1.13	2.26	3.40	4.25	5.07	6.83	8.05

歯面強さ (kW)

Allowable transfer capability table (kW) Surface Durability

回転速度 (min ⁻¹) revolution/min							
400	800	1,200	1,500	1,800	2,500	3,000	
0.190	0.38	0.58	0.73	0.88	1.24	1.48	
0.20	0.41	0.63	0.79	0.96	1.34	1.60	
0.22	0.45	0.68	0.86	1.04	1.45	1.73	
0.24	0.49	0.74	0.93	1.13	1.57	1.87	
0.26	0.52	0.80	1.01	1.22	1.69	2.01	
0.30	0.61	0.92	1.16	1.41	1.94	2.31	
0.34	0.69	1.05	1.33	1.61	2.21	2.62	
0.38	0.79	1.20	1.51	1.82	2.49	2.96	

The above numerical values are equivalent to JGMA formulas as reference only.

動力の換算式は P26 をご参照ください。Please refer to the conversion fomulas of power on page P26.

歯研平歯車

GROUND SPUR GEARS

モジュール
MODULE

1

圧力角 20° (並歯)

20° PRESSURE ANGLE FULL DEPTH TOOTH

歯部高周波焼き入れ HRC49 ~ 55
JIS B 1702-1 (ISO) 5 級
System of accuracy: JIS B1702-1(ISO) class 5



御注文には必ず“フルネームで商品記号”を明記してください。

Please refer to the catalogue reference while ordering.

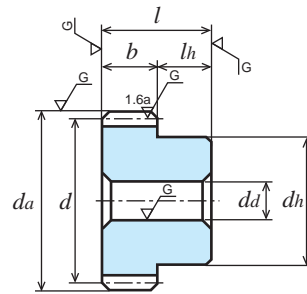

B1形
TYPE B1

SCM435、440 クロムモリブデン鋼 (JIS G 4053)

Material : Chromium Molybdenum Steel (ISO 34CrMo4, 42CrMo4)

単位 : mm
Dimensions : mm

商品記号 Catalogue Number	歯数 Number of Teeth <i>z</i>	基準円直径 Reference Diameter <i>d</i>	歯先円直径 Tip Diameter <i>da</i>	形 Type	歯幅 Face Width <i>b</i>	穴径 Bore Diameter <i>da</i> (H7)	ハブ外径 Hub Diameter <i>dh</i>	ハブ長さ Hub Projection <i>lh</i>	全長 Overall Length <i>l</i>	ねじ Set Screw		キリ Tap Guide <i>dr</i>	重量 Weight <i>W</i> (g)
										<i>M</i>	<i>ls</i>		
SG1S 35B - 1010	35	φ35	φ37	B1	10	φ10	φ26	10	20	-	-	-	104.2
SG1S 36B - 1010	36	φ36	φ38	B1	10	φ10	φ26	10	20	-	-	-	108.6
SG1S 38B - 1010	38	φ38	φ40	B1	10	φ10	φ26	10	20	-	-	-	117.6
SG1S 40B - 1010	40	φ40	φ42	B1	10	φ10	φ26	10	20	-	-	-	127.1
SG1S 40B - 1012	40	φ40	φ42	B1	10	φ12	φ26	10	20	-	-	-	121.7
SG1S 40B - 1015	40	φ40	φ42	B1	10	φ15	φ26	10	20	-	-	-	111.8
SG1S 42B - 1010	42	φ42	φ44	B1	10	φ10	φ35	10	20	-	-	-	170.9
SG1S 44B - 1010	44	φ44	φ46	B1	10	φ10	φ35	10	20	-	-	-	181.4
SG1S 45B - 1012	45	φ45	φ47	B1	10	φ12	φ35	10	20	-	-	-	181.5
SG1S 48B - 1012	48	φ48	φ50	B1	10	φ12	φ35	10	20	-	-	-	198.5
SG1S 50B - 1012	50	φ50	φ52	B1	10	φ12	φ35	10	20	-	-	-	210.6
SG1S 50B - 1015	50	φ50	φ52	B1	10	φ15	φ35	10	20	-	-	-	200.6
SG1S 50B - 1016	50	φ50	φ52	B1	10	φ16	φ35	10	20	-	-	-	196.8

Gear tooth surface completed with induction hardening, Hardness HRC49 to 55.

許容伝達動力表 曲げ強さ (kW)

Allowable transfer capability table (kW) Bending Strength

歯数 <i>z</i>	歯幅 <i>b</i>	回転速度 (min ⁻¹) revolution/min						
		400	800	1,200	1,500	1,800	2,500	3,000
35	10	1.17	2.35	3.53	4.41	5.25	7.07	8.34
36	10	1.22	2.44	3.66	4.58	5.44	7.32	8.63
38	10	1.31	2.62	3.93	4.93	5.81	7.80	9.21
40	10	1.40	2.88	4.20	5.23	6.18	8.30	9.80
42	10	1.49	2.98	4.47	5.54	6.54	8.79	10.37
44	10	1.58	3.16	4.73	5.85	6.90	9.28	10.94
45	10	1.62	3.25	4.87	6.01	7.08	9.53	11.23
48	10	1.76	3.52	5.27	6.47	7.62	10.26	12.08
50	10	1.85	3.70	5.53	6.78	7.98	10.75	12.64

The above numerical values are equivalent to JGMA formulas as reference only.

動力の換算式は P26 をご参照ください。Please refer to the conversion fomulas of power on page P26.

歯面強さ (kW)

Allowable transfer capability table (kW) Surface Durability

回転速度 (min ⁻¹) revolution/min						
400	800	1,200	1,500	1,800	2,500	3,000
0.41	0.83	1.27	1.60	1.93	2.64	3.14
0.43	0.89	1.35	1.70	2.04	2.79	3.33
0.49	0.99	1.51	1.91	2.27	3.11	3.71
0.54	1.11	1.69	2.12	2.53	3.45	4.12
0.60	1.23	1.87	2.34	2.79	3.81	4.54
0.66	1.35	2.06	2.57	3.06	4.18	4.98
0.69	1.42	2.16	2.69	3.20	4.38	5.21
0.79	1.62	2.47	3.06	3.64	4.98	5.93
0.86	1.76	2.68	3.32	3.94	5.41	6.43

目次
CONTENTS

インフォメーション
INFORMATION

ギヤボックス
GEAR BOXES

ノーバッキングギヤ
ANTI BACKLASH SPUR GEARS

歯研平歯車
GROUND SPUR GEARS

平歯車
SPUR GEARS

内歯車
INTERNAL GEARS

歯研ラック
GROUND RACKS

ラック
RACKS

斜歯車とスクリューギヤ
HELICAL GEARS AND SCREW GEARS

ワームとワームホイール
WORMS AND WORM WHEELS

かさ歯車
BEVEL GEARS

スプロケット
SPROCKETS

技術資料
REFERENCE DATA

歯研平歯車

GROUND SPUR GEARS

モジュール
MODULE

1

圧力角 20° (並歯)
20° PRESSURE ANGLE FULL DEPTH TOOTH

歯部高周波焼き入れ HRC49 ~ 55
JIS B 1702-1 (ISO) 5 級
System of accuracy: JIS B1702-1(ISO) class 5

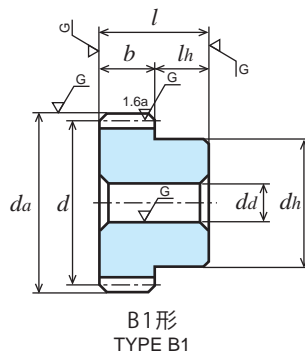

SCM435、440 クロムモリブデン鋼 (JIS G 4053)

Material : Chromium Molybdenum Steel (ISO 34CrMo4, 42CrMo4)

単位 : mm
Dimensions : mm

商品記号 Catalogue Number	歯数 Number of Teeth <i>z</i>	基準円直径 Reference Diameter <i>d</i>	歯先円直径 Tip Diameter <i>da</i>	形 Type	歯幅 Face Width <i>b</i>	穴径 Bore Diameter <i>dd</i> (H7)	ハブ外径 Hub Diameter <i>dh</i>	ハブ長さ Hub Projection <i>lh</i>	全長 Overall Length <i>l</i>	ねじ Set Screw		キリ Tap Guide <i>dr</i>	重量 Weight <i>W</i> (g)
										<i>M</i>	<i>ls</i>		
SG1S 52B - 1012	52	φ52	φ54	B1	10	φ12	φ35	10	20	-	-	-	228.4
SG1S 54B - 1012	54	φ54	φ56	B1	10	φ12	φ35	10	20	-	-	-	236.0
SG1S 55B - 1012	55	φ55	φ57	B1	10	φ12	φ35	10	20	-	-	-	248.1
SG1S 56B - 1012	56	φ56	φ58	B1	10	φ12	φ35	10	20	-	-	-	249.5
SG1S 60B - 1012	60	φ60	φ62	B1	10	φ12	φ40	10	20	-	-	-	300.9
SG1S 60B - 1015	60	φ60	φ62	B1	10	φ15	φ40	10	20	-	-	-	291.0
SG1S 60B - 1018	60	φ60	φ62	B1	10	φ18	φ40	10	20	-	-	-	278.9
SG1S 64B - 1012	64	φ64	φ66	B1	10	φ12	φ40	10	20	-	-	-	331.3
SG1S 70B - 1012	70	φ70	φ72	B1	10	φ12	φ40	10	20	-	-	-	380.6
SG1S 72B - 1012	72	φ72	φ74	B1	10	φ12	φ45	10	20	-	-	-	424.0
SG1S 75B - 1012	75	φ75	φ77	B1	10	φ12	φ45	10	20	-	-	-	451.0

Gear tooth surface completed with induction hhardening, Hardness HRC49 to 55.

許容伝達動力表 曲げ強さ (kW)

Allowable transfer capability table (kW) Bending Strength

歯数 <i>z</i>	歯幅 <i>b</i>	回転速度 (min ⁻¹) revolution/min						
		400	800	1,200	1,500	1,800	2,500	3,000
52	10	1.94	3.88	5.78	7.09	8.34	11.23	13.18
54	10	2.03	4.06	6.04	7.39	8.70	11.71	13.71
55	10	2.08	4.16	6.16	7.54	8.88	11.95	13.97
56	10	2.12	4.25	6.29	7.70	9.06	12.19	14.23
60	10	2.31	4.62	6.79	8.30	9.79	13.14	15.24
64	10	2.49	4.99	7.29	8.90	10.51	14.04	16.24
70	10	2.77	5.54	8.03	9.82	11.58	15.34	17.69
72	10	2.86	5.73	8.28	10.12	11.94	15.76	18.16
75	10	3.00	5.99	8.64	10.58	12.47	16.39	18.86

歯面強さ (kW)

Allowable transfer capability table (kW) Surface Durability

回転速度 (min ⁻¹) revolution/min							
400	800	1,200	1,500	1,800	2,500	3,000	
0.94	1.91	2.90	3.59	4.26	5.85	6.94	
1.01	2.07	3.13	3.87	4.60	6.31	7.46	
1.05	2.15	3.24	4.01	4.77	6.54	7.73	
1.09	2.23	3.36	4.16	4.95	6.78	8.00	
1.26	2.58	3.86	4.77	5.69	7.78	9.12	
1.44	2.95	4.39	5.43	6.47	8.82	10.31	
1.73	3.56	5.26	6.50	7.75	10.47	12.20	
1.84	3.77	5.56	6.88	8.20	11.04	12.86	
2.00	4.09	6.03	7.47	8.90	11.93	13.88	

The above numerical values are equivalent to JGMA formulas as reference only.

動力の換算式は P26 をご参照ください。Please refer to the conversion fomulas of power on page P26.

歯研平歯車

GROUND SPUR GEARS

モジュール
MODULE

1

圧力角 20° (並歯)

20° PRESSURE ANGLE FULL DEPTH TOOTH

歯部高周波焼き入れ HRC49 ~ 55
JIS B 1702-1 (ISO) 5 級
System of accuracy: JIS B1702-1(ISO) class 5



御注文には必ず“フルネームで商品記号”を明記してください。
Please refer to the catalogue reference while ordering.

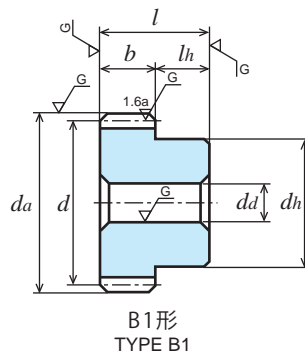

SCM435、440 クロムモリブデン鋼 (JIS G 4053)

Material : Chromium Molybdenum Steel (ISO 34CrMo4, 42CrMo4)

単位 : mm
Dimensions : mm

商品記号 Catalogue Number	歯数 Number of Teeth <i>z</i>	基準円直径 Reference Diameter <i>d</i>	歯先円直径 Tip Diameter <i>da</i>	形 Type	歯幅 Face Width <i>b</i>	穴径 Bore Diameter <i>da</i> (H7)	ハブ外径 Hub Diameter <i>dh</i>	ハブ長さ Hub Projection <i>lh</i>	全長 Overall Length <i>l</i>	ねじ Set Screw		キリ Tap Guide <i>dr</i>	重量 Weight <i>W</i> (g)
										<i>M</i>	<i>ls</i>		
SG1S 80B - 1012	80	φ 80	φ 82	B1	10	φ12	φ45	10	20	-	-	-	498.5
SG1S 80B - 1015	80	φ 80	φ 82	B1	10	φ15	φ45	10	20	-	-	-	488.6
SG1S 80B - 1020	80	φ 80	φ 82	B1	10	φ20	φ45	10	20	-	-	-	467.1
SG1S 90B - 1015	90	φ 90	φ 92	B1	10	φ15	φ50	10	20	-	-	-	621.8
SG1S 96B - 1015	96	φ 96	φ 98	B1	10	φ15	φ50	10	20	-	-	-	690.2
SG1S 100B - 1012	100	φ100	φ102	B1	10	φ12	φ50	10	20	-	-	-	748.1
SG1S 100B - 1015	100	φ100	φ102	B1	10	φ15	φ50	10	20	-	-	-	738.2
SG1S 100B - 1020	100	φ100	φ102	B1	10	φ20	φ50	10	20	-	-	-	716.8
SG1S 108B - 1015	108	φ108	φ110	B1	10	φ15	φ50	10	20	-	-	-	840.1
SG1S 112B - 1015	112	φ112	φ114	B1	10	φ15	φ50	10	20	-	-	-	894.0
SG1S 120B - 1015	120	φ120	φ122	B1	10	φ15	φ50	10	20	-	-	-	1007.7

Gear tooth surface completed with induction hardening, Hardness HRC49 to 55.

許容伝達動力表 曲げ強さ (kW)

Allowable transfer capability table (kW) Bending Strength

歯数 <i>z</i>	歯幅 <i>b</i>	回転速度 (min ⁻¹) revolution/min						
		400	800	1,200	1,500	1,800	2,500	3,000
80	10	3.24	6.42	9.25	11.33	13.34	17.42	20.08
90	10	3.70	7.26	10.47	12.80	14.98	19.37	22.47
96	10	3.98	7.77	11.20	13.68	15.92	20.59	23.88
100	10	4.17	8.10	11.68	14.25	16.53	21.40	24.80
108	10	4.55	8.76	12.64	15.34	17.73	23.01	26.60
112	10	4.74	9.09	13.11	15.86	18.32	23.80	27.48
120	10	5.12	9.74	14.05	16.89	19.46	25.34	28.97

The above numerical values are equivalent to JGMA formulas as reference only.

動力の換算式は P26 をご参照ください。Please refer to the conversion fomulas of power on page P26.

歯面強さ (kW)

Allowable transfer capability table (kW) Surface Durability

回転速度 (min ⁻¹) revolution/min							
400	800	1,200	1,500	1,800	2,500	3,000	
2.29	4.66	6.85	8.51	10.12	13.48	15.70	
2.92	5.90	8.69	10.77	12.74	16.80	19.69	
3.34	6.72	9.90	12.25	14.41	19.00	22.28	
3.64	7.29	10.74	13.28	15.57	20.56	24.07	
4.27	8.50	12.53	15.42	18.01	23.84	27.84	
4.61	9.13	13.48	16.53	19.29	25.55	29.80	
5.32	10.48	15.47	18.85	21.95	29.13	33.64	

目次
CONTENTS

インフォメーション
INFORMATION

ギヤボックス
GEAR BOXES

ノーバッキングギヤ
ANTI BACKLASH SPUR GEARS

歯研平歯車
GROUND SPUR GEARS

平歯車
SPUR GEARS

内歯車
INTERNAL GEARS

歯研ラック
GROUND RACKS

ラック
RACKS

へリカル・スクリューギヤ
HELICAL GEARS AND SCREW GEARS

ウォーム・ウォームギヤ
WORMS AND WORM GEARS

かさ歯車
BEVEL GEARS

スプロケット
SPROCKETS

技術資料
REFERENCE DATA

歯研平歯車

GROUND SPUR GEARS

モジュール **1.5** 圧力角 20° (並歯)
 MODULE 20° PRESSURE ANGLE FULL DEPTH TOOTH

歯部高周波焼き入れ HRC49 ~ 55
 JIS B 1702-1 (ISO) 5 級相当
 System of accuracy: JIS B1702-1(ISO) class 5

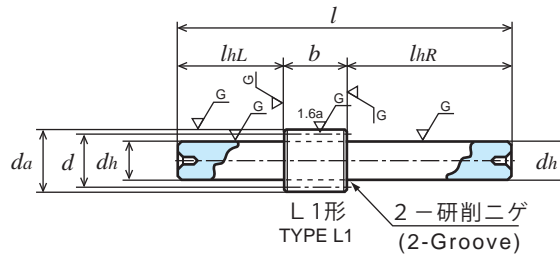

SCM435、440 クロムモリブデン鋼 (JIS G 4053)

Material : Chromium Molybdenum Steel (ISO 34CrMo4, 42CrMo4)

単位 : mm
 Dimensions : mm

商品記号 Catalogue Number	歯数 Number of Teeth <i>z</i>	基準円直径 Reference Diameter <i>d</i>	歯先円直径 Tip Diameter <i>da</i>	形 Type	歯幅 Face Width <i>b</i>	穴径 Bore Diameter <i>da</i> (H7)	ハブ外径 Hub Diameter <i>dh</i>	ハブ長さ Hub Projection <i>lh</i>	全長 Overall Length <i>l</i>	重量 Weight <i>W</i> (kg)
SG1.5S 14L - 1512	14	φ21	φ24	L1	15	-	φ12(h7)	L25 R60	100	0.12
SG1.5S 15L - 1512	15	φ22.5	φ25.5	L1	15	-	φ12(h7)	L25 R60	100	0.12
SG1.5S 15B - 1510	15	φ22.5	φ25.5	B1	15	φ10	φ18	15	30	0.06
SG1.5S 16L - 1512	16	φ24	φ27	L1	15	-	φ12(h7)	L25 R60	100	0.13
SG1.5S 16B - 1510	16	φ24	φ27	B1	15	φ10	φ18	15	30	0.06
SG1.5S 18L - 1512	18	φ27	φ30	L1	15	-	φ12(h7)	L25 R60	100	0.14
SG1.5S 18B - 1512	18	φ27	φ30	B1	15	φ12	φ22	15	30	0.08
SG1.5S 20B - 1512	20	φ30	φ33	B1	15	φ12	φ22	15	30	0.10
SG1.5S 22B - 1512	22	φ33	φ36	B1	15	φ12	φ25	15	30	0.13
SG1.5S 24B - 1515	24	φ36	φ39	B1	15	φ15	φ30	15	30	0.16
SG1.5S 25B - 1515	25	φ37.5	φ40.5	B1	15	φ15	φ30	15	30	0.17

Gear tooth surface completed with induction hardening, Hardness HRC49 to 55.

許容伝達動力表 曲げ強さ (kW)

Allowable transfer capability table (kW) Bending Strength

歯数 <i>z</i>	歯幅 <i>b</i>	回転速度 (min ⁻¹) revolution/min						
		400	800	1,200	1,500	1,800	2,500	3,000
14	15	1.03	2.07	3.11	3.89	4.67	6.49	7.73
15	15	1.16	2.32	3.49	4.36	5.23	7.27	8.61
16	15	1.29	2.58	3.87	4.84	5.81	8.04	9.50
18	15	1.55	3.11	4.66	5.82	6.99	9.58	11.30
20	15	1.82	3.65	5.47	6.84	8.20	11.14	13.11
22	15	2.10	4.20	6.29	7.87	9.41	12.69	14.94
24	15	2.38	4.75	7.13	8.91	10.59	14.25	16.80
25	15	2.52	5.04	7.55	9.44	11.18	15.02	17.74

The above references are JGMA standard.

動力の換算式は P26 をご参照ください。Please refer to the conversion formulas of power on page P26.

歯面強さ (kW)

Allowable transfer capability table (kW) Surface Durability

回転速度 (min ⁻¹) revolution/min						
400	800	1,200	1,500	1,800	2,500	3,000
0.21	0.43	0.66	0.83	1.00	1.41	1.69
0.24	0.50	0.76	0.96	1.16	1.63	1.95
0.28	0.57	0.87	1.09	1.32	1.86	2.20
0.36	0.74	1.12	1.41	1.70	2.36	2.81
0.45	0.92	1.39	1.75	2.12	2.92	3.47
0.55	1.11	1.69	2.14	2.57	3.53	4.19
0.66	1.34	2.03	2.56	3.07	4.19	5.00
0.72	1.45	2.21	2.79	3.33	4.55	5.42

歯研平歯車

GROUND SPUR GEARS

モジュール **1.5** 圧力角 20° (並歯)
 MODULE 20° PRESSURE ANGLE FULL DEPTH TOOTH

歯部高周波焼き入れ HRC49 ~ 55
 JIS B 1702-1 (ISO) 5 級
 System of accuracy: JIS B1702-1(ISO) class 5



御注文には必ず“フルネームで商品記号”を明記してください。
 Please refer to the catalogue reference while ordering.

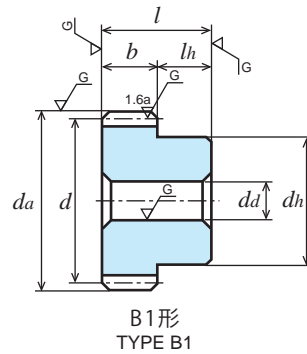

SCM435、440 クロムモリブデン鋼 (JIS G 4053)

Material : Chromium Molybdenum Steel (ISO 34CrMo4, 42CrMo4)

単位 : mm
 Dimensions : mm

商品記号 Catalogue Number	歯数 Number of Teeth <i>z</i>	基準円直径 Reference Diameter <i>d</i>	歯先円直径 Tip Diameter <i>da</i>	形 Type	歯幅 Face Width <i>b</i>	穴径 Bore Diameter <i>da</i> (H7)	ハブ外径 Hub Diameter <i>dh</i>	ハブ長さ Hub Projection <i>lh</i>	全長 Overall Length <i>l</i>	重量 Weight <i>W</i> (kg)
SG1.5S 26B - 1515	26	φ39	φ42	B1	15	φ15	φ30	15	30	0.18
SG1.5S 28B - 1515	28	φ42	φ45	B1	15	φ15	φ30	15	30	0.20
SG1.5S 30B - 1515	30	φ45	φ48	B1	15	φ15	φ35	15	30	0.26
SG1.5S 32B - 1515	32	φ48	φ51	B1	15	φ15	φ35	15	30	0.28
SG1.5S 34B - 1515	34	φ51	φ54	B1	15	φ15	φ35	15	30	0.31
SG1.5S 35B - 1515	35	φ52.5	φ55.5	B1	15	φ15	φ35	15	30	0.36
SG1.5S 36B - 1515	36	φ54	φ57	B1	15	φ15	φ40	15	30	0.37
SG1.5S 40B - 1515	40	φ60	φ63	B1	15	φ15	φ40	15	30	0.44
SG1.5S 42B - 1515	42	φ63	φ66	B1	15	φ15	φ40	15	30	0.47
SG1.5S 45B - 1520	45	φ67.5	φ70.5	B1	15	φ20	φ50	15	30	0.57
SG1.5S 48B - 1520	48	φ72	φ75	B1	15	φ20	φ50	15	30	0.63

Gear tooth surface completed with induction hardening, Hardness HRC49 to 55.

許容伝達動力表 曲げ強さ (kW)

Allowable transfer capability table (kW) Bending Strength

歯数 <i>z</i>	歯幅 <i>b</i>	回転速度 (min ⁻¹) revolution/min						
		400	800	1,200	1,500	1,800	2,500	3,000
26	15	2.66	5.32	7.98	9.96	11.77	15.81	18.67
28	15	2.95	5.90	8.84	10.97	12.96	17.41	20.54
30	15	3.24	6.47	9.71	11.98	14.13	19.00	22.39
32	15	3.53	7.06	10.59	12.99	15.30	20.59	24.24
34	15	3.83	7.65	11.42	13.99	16.47	22.18	26.08
35	15	3.97	7.95	11.83	14.49	17.05	22.97	26.94
36	15	4.12	8.25	12.25	15.00	17.64	23.76	27.81
40	15	4.72	9.45	13.90	16.98	20.03	26.90	31.19
42	15	5.03	10.05	14.72	17.97	21.22	28.40	32.85
45	15	5.48	10.96	15.94	19.47	22.98	30.55	35.27
48	15	5.94	11.87	17.16	20.98	24.74	32.67	37.64

The above references are JGMA standard.

動力の換算式は P26 をご参照ください。Please refer to the conversion formulas of power on page P26.

歯面強さ (kW)

Allowable transfer capability table (kW) Surface Durability

回転速度 (min ⁻¹) revolution/min							
400	800	1,200	1,500	1,800	2,500	3,000	
0.78	1.58	2.40	3.02	3.60	4.92	5.87	
0.90	1.84	2.80	3.51	4.18	5.71	6.81	
1.04	2.12	3.23	4.03	4.80	6.57	7.82	
1.19	2.43	3.70	4.59	5.45	7.47	8.89	
1.35	2.75	4.18	5.18	6.15	8.44	10.03	
1.43	2.93	4.43	5.49	6.52	8.94	10.60	
1.52	3.10	4.69	5.80	6.90	9.46	11.19	
1.89	3.87	5.79	7.16	8.53	11.67	13.69	
2.09	4.28	6.39	7.89	9.41	12.83	15.01	
2.41	4.94	7.33	9.06	10.81	14.65	17.10	
2.76	5.66	8.34	10.32	12.30	16.56	19.29	

目次
CONTENTS

インフォメーション
INFORMATION

ギヤボックス
GEAR BOXES

ノーバッキングギヤ
ANTI BACKLASH SPUR GEARS

歯研平歯車
GROUND SPUR GEARS

平歯車
SPUR GEARS

内歯車
INTERNAL GEARS

歯研ラック
GROUND RACKS

ラック
RACKS

へリカル・スクリューギヤ
HELICAL GEARS AND SCREW GEARS

ウォーム・ウォームギヤ
WORMS AND WORM GEARS

かさ歯車
BEVEL GEARS

スプロケット
SPROCKETS

技術データ
REFERENCE DATA

歯研平歯車

GROUND SPUR GEARS

モジュール **1.5** 圧力角 20° (並歯)
 MODULE 20° PRESSURE ANGLE FULL DEPTH TOOTH

歯部高周波焼き入れ HRC49 ~ 55
 JIS B 1702-1 (ISO) 5 級
 System of accuracy: JIS B1702-1(ISO) class 5

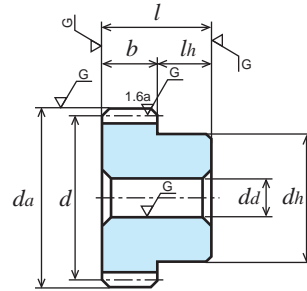

B1形
TYPE B1

SCM435、440 クロムモリブデン鋼 (JIS G 4053)

Material : Chromium Molybdenum Steel (ISO 34CrMo4, 42CrMo4)

単位 : mm
Dimensions : mm

商品記号 Catalogue Number	歯数 Number of Teeth <i>z</i>	基準円直径 Reference Diameter <i>d</i>	歯先円直径 Tip Diameter <i>da</i>	形 Type	歯幅 Face Width <i>b</i>	穴径 Bore Diameter <i>da</i> (H7)	ハブ外径 Hub Diameter <i>dh</i>	ハブ長さ Hub Projection <i>lh</i>	全長 Overall Length <i>l</i>	重量 Weight <i>W</i> (kg)
SG1.5S 50B - 1520	50	φ 75	φ 78	B1	15	φ20	φ50	15	30	0.67
SG1.5S 52B - 1520	52	φ 78	φ 81	B1	15	φ20	φ50	15	30	0.72
SG1.5S 55B - 1520	55	φ 82.5	φ 85.5	B1	15	φ20	φ50	15	30	0.78
SG1.5S 56B - 1520	56	φ 84	φ 87	B1	15	φ20	φ50	15	30	0.80
SG1.5S 60B - 1520	60	φ 90	φ 93	B1	15	φ20	φ60	15	30	1.00
SG1.5S 64B - 1520	64	φ 96	φ 99	B1	15	φ20	φ60	15	30	1.10
SG1.5S 70B - 1520	70	φ105	φ108	B1	15	φ20	φ60	15	30	1.27
SG1.5S 72B - 1520	72	φ108	φ111	B1	15	φ20	φ60	15	30	1.33
SG1.5S 75B - 1520	75	φ112.5	φ115.5	B1	15	φ20	φ60	15	30	1.42
SG1.5S 80B - 1520	80	φ120	φ123	B1	15	φ20	φ60	15	30	1.58
SG1.5S 90B - 1525	90	φ135	φ138	B1	15	φ25	φ70	15	30	2.01
SG1.5S 100B - 1525	100	φ150	φ153	B1	15	φ25	φ70	15	30	2.40
SG1.5S 112B - 1525	112	φ168	φ171	B1	15	φ25	φ70	15	30	2.93
SG1.5S 120B - 1525	120	φ180	φ183	B1	15	φ25	φ70	15	30	3.31

Gear tooth surface completed with induction hardening, Hardness HRC49 to 55.

許容伝動力表 曲げ強さ (kW)

Allowable transfer capability table (kW) Bending Strength

歯数 <i>z</i>	歯幅 <i>b</i>	回転速度 (min ⁻¹) revolution/min						
		400	800	1,200	1,500	1,800	2,500	3,000
50	15	6.24	12.44	17.96	21.99	25.91	34.07	39.20
52	15	6.55	13.02	18.76	22.99	27.07	35.44	40.80
55	15	7.01	13.87	19.98	24.48	28.79	37.47	43.26
56	15	7.17	14.15	20.39	24.97	29.36	38.14	44.07
60	15	7.79	15.29	22.03	26.94	31.52	40.76	47.28
64	15	8.41	16.41	23.65	28.88	33.62	43.48	50.43
70	15	9.35	18.07	26.06	31.71	36.68	47.56	55.02
72	15	9.67	18.62	26.86	32.60	37.68	48.90	56.52
75	15	10.14	19.44	28.05	33.92	39.16	50.88	58.74
80	15	10.93	20.80	30.01	36.08	41.57	54.12	61.89
90	15	12.49	23.55	33.71	40.22	46.39	60.33	67.34
100	15	14.03	26.28	37.20	44.20	51.28	65.34	72.38
112	15	15.78	29.50	41.21	49.15	56.93	70.67	-
120	15	16.94	31.61	43.79	52.40	60.57	73.96	-

The above references are JGMA standard.

動力の換算式は P26 をご参照ください。Please refer to the conversion formulas of power on page P26.

歯面強さ (kW)

Allowable transfer capability table (kW) Surface Durability

回転速度 (min ⁻¹) revolution/min							
400	800	1,200	1,500	1,800	2,500	3,000	
3.00	6.14	9.04	11.21	13.34	17.90	20.82	
3.26	6.64	9.78	12.13	14.43	19.27	22.43	
3.66	7.44	10.94	13.57	16.14	21.42	25.00	
3.80	7.71	11.35	14.07	16.72	22.15	25.88	
4.39	8.86	13.04	16.15	19.11	25.19	29.54	
5.02	10.08	14.85	18.37	21.61	28.51	33.41	
6.05	12.05	17.77	21.91	25.62	33.87	39.60	
6.41	12.75	18.80	23.12	27.02	35.75	41.76	
6.98	13.82	20.40	25.00	29.18	38.65	45.08	
7.99	15.72	23.20	28.27	32.93	43.70	50.47	
10.21	19.93	29.21	35.32	41.18	54.56	61.49	
12.68	24.63	35.71	43.00	50.42	65.43	73.16	
15.93	30.91	44.24	53.46	62.57	79.05	-	
18.29	35.47	50.34	61.03	71.27	88.54	-	

歯研平歯車 GROUND SPUR GEARS

モジュール
MODULE

2

圧力角 20° (並歯)
20° PRESSURE ANGLE FULL DEPTH TOOTH

歯部高周波焼き入れ HRC49 ~ 55
JIS B 1702-1 (ISO) 5 級
System of accuracy: JIS B1702-1(ISO) class 5



御注文には必ず“フルネームで商品記号”を明記してください。
Please refer to the catalogue reference while ordering.

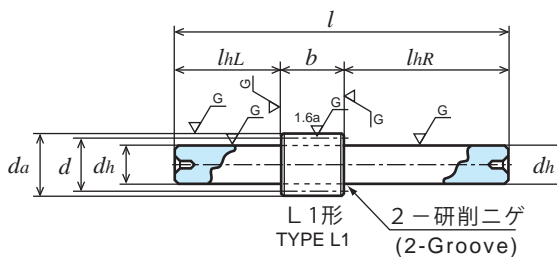

SCM435、440 クロムモリブデン鋼 (JIS G 4053) Material : Chromium Molybdenum Steel (ISO 34CrMo4, 42CrMo4)

単位 : mm
Dimensions : mm

商品記号 Catalogue Number	歯数 Number of Teeth <i>z</i>	基準円直径 Reference Diameter <i>d</i>	歯先円直径 Tip Diameter <i>da</i>	形 Type	歯幅 Face Width <i>b</i>	穴径 Bore Diameter <i>da</i> (H7)	ハブ外径 Hub Diameter <i>dh</i>	ハブ長さ Hub Projection <i>lh</i>	全長 Overall Length <i>l</i>	重量 Weight <i>W</i> (kg)
SG2S 14L - 2012	14	φ28	φ32	L1	20	-	φ12 (h7)	L25 R60	105	0.17
SG2S 14B - 2012	14	φ28	φ32	B1	20	φ12	φ22	20	40	0.12
SG2S 15L - 2012	15	φ30	φ34	L1	20	-	φ12 (h7)	L25 R60	105	0.19
SG2S 15B - 2012	15	φ30	φ34	B1	20	φ12	φ22	20	40	0.13
SG2S 16L - 2015	16	φ32	φ36	L1	20	-	φ15 (h7)	L25 R60	105	0.24
SG2S 16B - 2012	16	φ32	φ36	B1	20	φ12	φ25	20	40	0.17
SG2S 17B - 2012	17	φ34	φ38	B1	20	φ12	φ25	20	40	0.18
SG2S 18L - 2015	18	φ36	φ40	L1	20	-	φ15 (h7)	L25 R60	105	0.28
SG2S 18B - 2015	18	φ36	φ40	B1	20	φ15	φ30	20	40	0.21
SG2S 20B - 2015	20	φ40	φ44	B1	20	φ15	φ30	20	40	0.25
SG2S 21B - 2015	21	φ42	φ46	B1	20	φ15	φ30	20	40	0.27
SG2S 22B - 2015	22	φ44	φ48	B1	20	φ15	φ30	20	40	0.29
SG2S 23B - 2015	23	φ46	φ50	B1	20	φ15	φ30	20	40	0.31
SG2S 24B - 2015	24	φ48	φ52	B1	20	φ15	φ40	20	40	0.42

Gear tooth surface completed with induction hardening, Hardness HRC49 to 55.

許容伝達動力表 曲げ強さ (kW)

Allowable transfer capability table (kW) Bending Strength

歯数 <i>z</i>	歯幅 <i>b</i>	回転速度 (min ⁻¹) revolution/min						
		400	800	1,200	1,500	1,800	2,500	3,000
14	20	2.46	4.92	7.39	9.23	11.08	15.13	17.84
15	20	2.76	5.52	8.28	10.35	12.42	16.85	19.84
16	20	3.06	6.12	9.19	11.48	13.77	18.58	21.86
17	20	3.37	6.74	10.11	12.63	15.08	20.32	23.94
18	20	3.68	7.36	11.04	13.80	16.40	22.06	26.02
20	20	4.32	8.64	12.96	16.15	19.08	25.63	30.25
21	20	4.64	9.29	13.93	17.29	20.41	27.43	32.36
22	20	4.97	9.94	14.92	18.44	21.75	29.25	34.47
23	20	5.30	10.61	15.91	19.59	23.09	31.06	36.59
24	20	5.63	11.27	16.90	20.73	24.42	32.87	38.68

The above references are JGMA standard.

動力の換算式は P26 をご参照ください。Please refer to the conversion formulas of power on page P26.

歯面強さ (kW)

Allowable transfer capability table (kW) Surface Durability

回転速度 (min ⁻¹) revolution/min						
400	800	1,200	1,500	1,800	2,500	3,000
0.52	1.06	1.60	2.02	2.44	3.39	4.03
0.60	1.22	1.85	2.33	2.82	3.89	4.62
0.69	1.39	2.12	2.67	3.23	4.42	5.25
0.78	1.58	2.40	3.08	3.65	4.99	5.94
0.88	1.78	2.71	3.41	4.09	5.59	6.66
1.09	2.22	3.37	4.24	5.05	6.90	8.23
1.21	2.45	3.73	4.68	5.57	7.62	9.08
1.33	2.70	4.11	5.14	6.11	8.37	9.97
1.45	2.96	4.51	5.62	6.68	9.15	10.89
1.59	3.24	4.93	6.12	7.27	9.97	11.86

目次
CONTENTS

インフォメーション
INFORMATION

ギヤボックス
GEAR BOXES

ノーバッキングギヤ
ANTI BACKLASH SPUR GEARS

歯研平歯車
GROUND SPUR GEARS

平歯車
SPUR GEARS

内歯車
INTERNAL GEARS

歯研ラック
GROUND RACKS

ラック
RACKS

ハニカムギヤ
HEXAGONAL GEAR AND SCREW GEARS

ワーム
WORMS AND WORM WHEELS

かさ歯車
BEVEL GEARS

スプロケット
SPROCKETS

技術資料
REFERENCE DATA

歯研平歯車

GROUND SPUR GEARS

モジュール
MODULE

2

圧力角 20° (並歯)
20° PRESSURE ANGLE FULL DEPTH TOOTH

歯部高周波焼き入れ HRC49 ~ 55
JIS B 1702-1 (ISO) 5 級
System of accuracy: JIS B1702-1(ISO) class 5

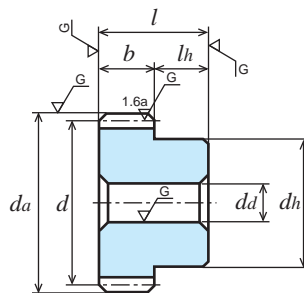

B1形
TYPE B1

SCM435、440 クロムモリブデン鋼 (JIS G 4053)

Material : Chromium Molybdenum Steel (ISO 34CrMo4, 42CrMo4)

単位 : mm
Dimensions : mm

商品記号 Catalogue Number	歯数 Number of Teeth <i>z</i>	基準円直径 Reference Diameter <i>d</i>	歯先円直径 Tip Diameter <i>da</i>	形 Type	歯幅 Face Width <i>b</i>	穴径 Bore Diameter <i>da</i> (H7)	ハブ外径 Hub Diameter <i>dh</i>	ハブ長さ Hub Projection <i>lh</i>	全長 Overall Length <i>l</i>	重量 Weight <i>W</i> (kg)
SG2S 25B - 2015	25	φ50	φ54	B1	20	φ15	φ40	20	40	0.45
SG2S 26B - 2015	26	φ52	φ56	B1	20	φ15	φ40	20	40	0.47
SG2S 27B - 2015	27	φ54	φ58	B1	20	φ15	φ40	20	40	0.50
SG2S 28B - 2015	28	φ56	φ60	B1	20	φ15	φ40	20	40	0.53
SG2S 30B - 2015	30	φ60	φ64	B1	20	φ15	φ40	20	40	0.58
SG2S 32B - 2020	32	φ64	φ68	B1	20	φ20	φ50	20	40	0.71
SG2S 34B - 2020	34	φ68	φ72	B1	20	φ20	φ50	20	40	0.77
SG2S 35B - 2020	35	φ70	φ74	B1	20	φ20	φ50	20	40	0.81
SG2S 36B - 2020	36	φ72	φ76	B1	20	φ20	φ50	20	40	0.84
SG2S 38B - 2020	38	φ76	φ80	B1	20	φ20	φ60	20	40	1.05
SG2S 40B - 2020	40	φ80	φ84	B1	20	φ20	φ60	20	40	1.13
SG2S 42B - 2020	42	φ84	φ88	B1	20	φ20	φ60	20	40	1.21
SG2S 44B - 2020	44	φ88	φ92	B1	20	φ20	φ60	20	40	1.29
SG2S 45B - 2020	45	φ90	φ94	B1	20	φ20	φ60	20	40	1.34

Gear tooth surface completed with induction hardening, Hardness HRC49 to 55.

許容伝動力表 曲げ強さ (kW)

Allowable transfer capability table (kW) Bending Strength

歯数 <i>z</i>	歯幅 <i>b</i>	回転速度 (min ⁻¹) revolution/min						
		400	800	1,200	1,500	1,800	2,500	3,000
25	20	5.97	11.94	17.84	21.88	25.76	34.68	40.79
26	20	6.31	12.61	18.79	23.03	27.09	36.49	42.84
27	20	6.65	13.29	19.75	24.17	28.44	38.30	44.83
28	20	6.99	13.98	20.70	25.32	29.82	40.11	46.80
30	20	7.67	15.35	22.59	27.59	32.55	43.69	50.68
32	20	8.37	16.76	24.48	29.87	35.28	47.14	54.51
34	20	9.07	18.14	26.36	32.21	38.01	50.49	58.27
35	20	9.42	18.84	27.30	33.38	39.37	52.14	60.13
36	20	9.77	19.54	28.24	34.54	40.73	53.78	61.97
38	20	10.48	20.87	30.11	36.87	43.43	57.03	65.60
40	20	11.20	22.20	31.97	39.19	46.12	60.23	69.43
42	20	11.91	23.52	33.89	41.49	48.80	63.37	73.24
44	20	12.62	24.82	35.77	43.76	51.30	66.42	76.96
45	20	12.99	25.48	36.72	44.90	52.55	67.94	78.82

歯面強さ (kW)

Allowable transfer capability table (kW) Surface Durability

回転速度 (min ⁻¹) revolution/min							
400	800	1,200	1,500	1,800	2,500	3,000	
1.73	3.52	5.36	6.64	7.89	10.82	12.86	
1.87	3.82	5.80	7.18	8.53	11.70	13.88	
2.03	4.14	6.25	7.74	9.19	12.62	14.92	
2.18	4.66	6.73	8.32	9.90	13.57	16.00	
2.52	5.15	7.72	9.55	11.37	15.56	18.25	
2.88	5.90	8.79	10.85	12.95	17.64	20.62	
3.27	6.69	9.92	12.27	14.63	19.81	23.11	
3.47	7.11	10.51	13.00	15.50	20.93	24.40	
3.68	7.54	11.12	13.76	16.40	22.08	25.72	
4.12	8.41	12.38	15.35	18.27	24.47	28.45	
4.58	9.32	13.71	17.01	20.24	26.95	31.41	
5.07	10.28	15.13	18.76	22.30	29.54	34.50	
5.58	11.29	16.62	20.59	24.40	32.22	37.73	
5.85	11.81	17.38	21.53	25.47	33.59	39.39	

The above references are JGMA standard.

動力の換算式は P26 をご参照ください。Please refer to the conversion formulas of power on page P26.

歯研平歯車

GROUND SPUR GEARS

モジュール
MODULE

2

圧力角 20° (並歯)
20° PRESSURE ANGLE FULL DEPTH TOOTH

歯部高周波焼き入れ HRC49 ~ 55
JIS B 1702-1 (ISO) 5 級
System of accuracy: JIS B1702-1(ISO) class 5



御注文には必ず“フルネームで商品記号”を明記してください。
Please refer to the catalogue reference while ordering.

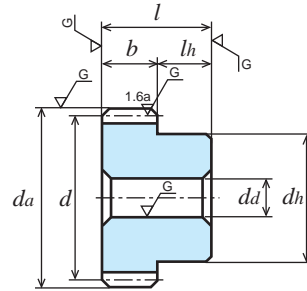

B1形
TYPE B1

SCM435、440 クロムモリブデン鋼 (JIS G 4053)

Material : Chromium Molybdenum Steel (ISO 34CrMo4, 42CrMo4)

単位 : mm
Dimensions : mm

商品記号 Catalogue Number	歯数 Number of Teeth <i>z</i>	基準円直径 Reference Diameter <i>d</i>	歯先円直径 Tip Diameter <i>da</i>	形 Type	歯幅 Face Width <i>b</i>	穴径 Bore Diameter <i>da</i> (H7)	ハブ外径 Hub Diameter <i>dh</i>	ハブ長さ Hub Projection <i>lh</i>	全長 Overall Length <i>l</i>	重量 Weight <i>W</i> (kg)
SG2S 48B - 2020	48	φ 96	φ100	B1	20	20	φ60	20	40	1.47
SG2S 50B - 2020	50	φ100	φ104	B1	20	20	φ60	20	40	1.57
SG2S 52B - 2020	52	φ104	φ108	B1	20	20	φ60	20	40	1.67
SG2S 54B - 2020	54	φ108	φ112	B1	20	20	φ60	20	40	1.78
SG2S 55B - 2020	55	φ110	φ114	B1	20	20	φ60	20	40	1.83
SG2S 56B - 2020	56	φ112	φ116	B1	20	20	φ60	20	40	1.88
SG2S 60B - 2025	60	φ120	φ124	B1	20	25	φ70	20	40	2.21
SG2S 64B - 2025	64	φ128	φ132	B1	20	25	φ70	20	40	2.45
SG2S 70B - 2025	70	φ140	φ144	B1	20	25	φ70	20	40	2.85
SG2S 72B - 2025	72	φ144	φ148	B1	20	25	φ80	20	40	3.17
SG2S 75B - 2025	75	φ150	φ154	B1	20	25	φ80	20	40	3.39
SG2S 80B - 2025	80	φ160	φ164	B1	20	25	φ80	20	40	3.77
SG2S 90B - 2025	90	φ180	φ184	B1	20	25	φ80	20	40	4.60
SG2S 100B - 2030	100	φ200	φ204	B1	20	30	φ80	20	40	5.46

Gear tooth surface completed with induction hardening, Hardness HRC49 to 55.

許容伝動力表 曲げ強さ (kW)

Allowable transfer capability table (kW) Bending Strength

歯数 <i>z</i>	歯幅 <i>b</i>	回転速度 (min ⁻¹) revolution/min						
		400	800	1,200	1,500	1,800	2,500	3,000
48	20	14.07	27.44	39.56	48.31	56.23	72.72	84.34
50	20	14.80	28.74	41.44	50.56	58.64	75.93	87.96
52	20	15.53	30.04	43.31	52.74	61.03	79.10	91.54
54	20	16.26	31.33	45.17	54.83	63.38	82.24	95.07
55	20	16.63	31.97	46.10	55.87	64.54	83.80	96.81
56	20	16.99	32.61	47.03	56.90	65.70	85.35	98.55
60	20	18.46	35.16	50.71	60.97	70.25	91.46	104.57
64	20	19.94	37.77	54.34	64.96	74.72	97.43	109.96
70	20	22.17	41.66	59.39	70.76	81.78	105.82	117.59
72	20	22.90	42.94	61.04	72.65	84.09	108.14	120.01
75	20	23.95	44.86	63.49	75.44	87.52	111.53	123.54
80	20	25.68	48.04	67.49	80.31	93.15	116.96	-
90	20	29.06	54.23	75.12	89.89	103.90	126.88	-
100	20	32.41	60.17	82.79	99.19	113.41	-	-

The above references are JGMA standard.

動力の換算式は P26 をご参照ください。Please refer to the conversion formulas of power on page P26.

歯面強さ (kW)

Allowable transfer capability table (kW) Surface Durability

回転速度 (min ⁻¹) revolution/min						
400	800	1,200	1,500	1,800	2,500	3,000
6.69	13.44	19.80	24.49	28.82	38.01	44.55
7.28	14.58	21.49	26.56	31.15	41.12	48.14
7.90	15.76	23.24	28.68	33.55	44.34	51.85
8.55	16.99	25.07	30.83	36.03	47.67	55.67
8.88	17.63	26.01	31.93	37.30	49.37	57.63
9.22	18.27	26.96	33.05	38.58	51.10	59.61
10.65	20.95	30.93	37.69	43.91	58.26	67.29
12.18	23.87	35.16	42.59	49.53	65.82	75.02
14.69	28.59	41.75	50.41	58.89	77.64	87.09
15.58	30.26	44.06	53.14	62.17	81.44	91.23
16.91	32.84	47.61	57.34	67.23	87.25	97.54
19.26	37.38	53.80	64.88	76.04	97.20	-
24.39	47.29	67.12	81.37	95.03	118.05	-
30.11	58.13	81.94	99.45	114.85	-	-

目次
CONTENTS

インフォメーション
INFORMATION

ギヤボックス
GEAR BOXES

ノーバックラッシュギヤ
ANTI BACKLASH SPUR GEARS

歯研平歯車
GROUND SPUR GEARS

平歯車
SPUR GEARS

内歯車
INTERNAL GEARS

歯研ラック
GROUND RACKS

ラック
RACKS

ハニカム・スクリューギヤ
HELICAL GEARS AND SCREW GEARS

ウォーム・ウォームギヤ
WORMS AND WORM GEARS

かさね歯車
BEVEL GEARS

スプロケット
SPROCKETS

技術仕様
REFERENCE DATA

歯研平歯車

GROUND SPUR GEARS

モジュール **2.5** 圧力角 20° (並歯)
 MODULE 2.5 20° PRESSURE ANGLE FULL DEPTH TOOTH

歯部高周波焼き入れ HRC49 ~ 55
 JIS B 1702-1 (ISO) 5 級
 System of accuracy: JIS B1702-1(ISO) class 5

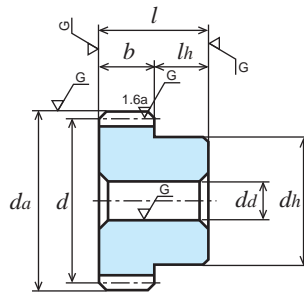

B1形
TYPE B1

SCM435、440 クロムモリブデン鋼 (JIS G 4053)

Material : Chromium Molybdenum Steel (ISO 34CrMo4, 42CrMo4)

単位 : mm
Dimensions : mm

商品記号 Catalogue Number	歯数 Number of Teeth <i>z</i>	基準円直径 Reference Diameter <i>d</i>	歯先円直径 Tip Diameter <i>da</i>	形 Type	歯幅 Face Width <i>b</i>	穴径 Bore Diameter <i>da</i> (H7)	ハブ外径 Hub Diameter <i>dh</i>	ハブ長さ Hub Projection <i>lh</i>	全長 Overall Length <i>l</i>	重量 Weight <i>W</i> (kg)
SG2.5S 14B - 2515	14	φ35	φ40	B1	25	φ15	φ28	20	45	0.2
SG2.5S 15B - 2515	15	φ37.5	φ42.5	B1	25	φ15	φ28	20	45	0.3
SG2.5S 16B - 2515	16	φ40	φ45	B1	25	φ15	φ28	20	45	0.3
SG2.5S 18B - 2520	18	φ45	φ50	B1	25	φ20	φ38	20	45	0.4
SG2.5S 20B - 2520	20	φ50	φ55	B1	25	φ20	φ38	20	45	0.5
SG2.5S 24B - 2520	24	φ60	φ65	B1	25	φ20	φ50	20	45	0.8
SG2.5S 25B - 2520	25	φ62.5	φ67.5	B1	25	φ20	φ50	20	45	0.8
SG2.5S 28B - 2520	28	φ70	φ75	B1	25	φ20	φ60	20	45	1.1
SG2.5S 30B - 2520	30	φ75	φ80	B1	25	φ20	φ60	20	45	1.2
SG2.5S 32B - 2520	32	φ80	φ85	B1	25	φ20	φ60	20	45	1.3
SG2.5S 35B - 2525	35	φ87.5	φ92.5	B1	25	φ25	φ70	20	45	1.6
SG2.5S 36B - 2525	36	φ90	φ95	B1	25	φ25	φ70	20	45	1.7

Gear tooth surface completed with induction hardening, Hardness HRC49 to 55.

許容伝達動力表 曲げ強さ (kW)

Allowable transfer capability table (kW) Bending Strength

歯数 <i>z</i>	歯幅 <i>b</i>	回転速度 (min ⁻¹) revolution/min						
		400	800	1,200	1,500	1,800	2,500	3,000
14	25	4.81	9.62	14.42	18.03	21.48	28.91	34.08
15	25	5.39	10.78	16.17	20.21	23.93	32.14	37.95
16	25	5.98	11.96	17.94	22.35	26.40	35.46	41.86
18	25	7.19	14.38	21.57	26.60	31.38	42.19	49.72
20	25	8.44	16.88	25.23	30.94	36.42	49.04	57.68
24	25	11.00	22.01	32.39	39.57	46.67	62.66	72.67
25	25	11.66	23.32	34.18	41.73	49.27	65.97	76.34
28	25	13.65	27.30	39.56	48.36	57.05	75.55	87.13
30	25	14.99	29.87	43.11	52.78	62.19	81.77	94.10
32	25	16.34	32.40	46.67	57.20	67.33	87.92	101.35
35	25	18.40	36.19	52.15	63.81	74.84	96.92	112.26
36	25	19.09	37.45	53.97	66.00	77.24	99.87	115.86

歯面強さ (kW)

Allowable transfer capability table (kW) Surface Durability

回転速度 (min ⁻¹) revolution/min							
400	800	1,200	1,500	1,800	2,500	3,000	
1.03	2.10	3.19	4.02	4.83	6.61	7.87	
1.19	2.42	3.68	4.65	5.55	7.58	9.04	
1.36	2.77	4.21	5.30	6.32	8.63	10.29	
1.74	3.54	5.39	6.72	7.99	10.94	13.03	
2.16	4.41	6.69	8.30	9.86	13.52	16.07	
3.15	6.44	9.66	11.93	14.22	19.45	22.81	
3.43	7.02	10.48	12.94	15.43	21.07	24.64	
4.34	8.89	13.14	16.26	19.37	26.16	30.51	
5.00	10.23	15.07	18.68	22.24	29.83	34.70	
5.72	11.65	17.13	21.26	25.30	33.69	39.26	
6.89	13.95	20.53	25.44	30.17	39.85	46.65	
7.31	14.76	21.73	26.92	31.84	41.99	49.24	

The above references are JGMA standard.

動力の換算式は P26 をご参照ください。Please refer to the conversion formulas of power on page P26.

歯研平歯車

GROUND SPUR GEARS

モジュール **2.5** 圧力角 20° (並歯)
 MODULE 2.5 20° PRESSURE ANGLE FULL DEPTH TOOTH

歯部高周波焼き入れ HRC49 ~ 55
 JIS B 1702-1 (ISO) 5 級
 System of accuracy: JIS B1702-1(ISO) class 5



御注文には必ず“フルネームで商品記号”を明記してください。
 Please refer to the catalogue reference while ordering.

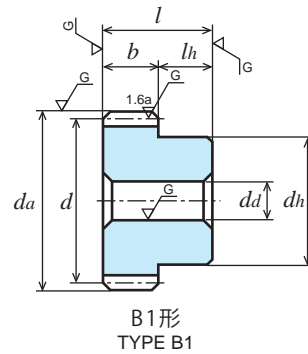

SCM435、440 クロムモリブデン鋼 (JIS G 4053)

Material : Chromium Molybdenum Steel (ISO 34CrMo4, 42CrMo4)

単位 : mm
 Dimensions : mm

商品記号 Catalogue Number	歯数 Number of Teeth <i>z</i>	基準円直径 Reference Diameter <i>d</i>	歯先円直径 Tip Diameter <i>da</i>	形 Type	歯幅 Face Width <i>b</i>	穴径 Bore Diameter <i>da</i> (H7)	ハブ外径 Hub Diameter <i>dh</i>	ハブ長さ Hub Projection <i>lh</i>	全長 Overall Length <i>l</i>	重量 Weight <i>W</i> (kg)
SG2.5S 40B - 2525	40	φ100	φ105	B1	25	φ25	φ70	20	45	2.0
SG2.5S 45B - 2525	45	φ112.5	φ117.5	B1	25	φ25	φ70	20	45	2.4
SG2.5S 48B - 2525	48	φ120	φ125	B1	25	φ25	φ70	20	45	2.5
SG2.5S 50B - 2530	50	φ125	φ130	B1	25	φ30	φ80	20	45	2.8
SG2.5S 55B - 2530	55	φ137.5	φ142.5	B1	25	φ30	φ80	20	45	3.4
SG2.5S 56B - 2530	56	φ140	φ145	B1	25	φ30	φ80	20	45	3.5
SG2.5S 60B - 2530	60	φ150	φ155	B1	25	φ30	φ80	20	45	4.0
SG2.5S 64B - 2530	64	φ160	φ165	B1	25	φ30	φ80	20	45	4.5
SG2.5S 70B - 2530	70	φ175	φ180	B1	25	φ30	φ90	20	45	5.4
SG2.5S 72B - 2530	72	φ180	φ185	B1	25	φ30	φ90	20	45	5.7
SG2.5S 75B - 2530	75	φ187.5	φ192.5	B1	25	φ30	φ90	20	45	6.1
SG2.5S 80B - 2530	80	φ200	φ205	B1	25	φ30	φ90	20	45	6.9

Gear tooth surface completed with induction hardening, Hardness HRC49 to 55.

許容伝達動力表 曲げ強さ (kW)

Allowable transfer capability table (kW) Bending Strength

歯数 <i>z</i>	歯幅 <i>b</i>	回転速度 (min ⁻¹) revolution/min						
		400	800	1,200	1,500	1,800	2,500	3,000
40	25	21.87	42.47	61.23	74.71	86.65	112.19	129.97
45	25	25.36	48.64	70.16	84.85	97.96	127.28	146.94
48	25	27.48	52.33	75.48	90.76	104.57	136.13	155.65
50	25	28.90	54.85	79.00	94.63	108.89	141.94	160.97
55	25	32.47	61.12	87.29	104.08	120.17	156.12	173.61
56	25	33.19	62.36	88.91	105.93	122.43	158.43	176.03
60	25	35.94	67.32	95.27	113.22	131.34	167.37	185.40
64	25	38.61	72.24	101.49	120.77	140.07	175.88	-
70	25	42.59	79.53	110.56	132.11	152.83	187.90	-
72	25	43.91	81.94	113.52	135.82	157.00	191.72	-
75	25	45.87	85.53	117.88	141.33	163.16	197.29	-
80	25	49.13	91.20	125.49	150.35	171.91	-	-

The above references are JGMA standard.

動力の換算式は P26 をご参照ください。Please refer to the conversion formulas of power on page P26.

歯面強さ (kW)

Allowable transfer capability table (kW) Surface Durability

回転速度 (min ⁻¹) revolution/min							
400	800	1,200	1,500	1,800	2,500	3,000	
9.10	18.22	26.86	33.20	38.93	51.40	60.18	
11.63	23.04	34.00	41.67	48.64	64.42	75.14	
13.31	26.19	38.67	47.12	54.88	72.83	84.11	
14.49	28.44	41.94	50.91	59.22	78.68	90.11	
17.69	34.47	50.42	60.92	71.11	94.11	105.66	
18.36	35.74	52.18	63.02	73.62	97.04	108.86	
21.14	41.06	59.51	71.67	84.04	109.06	121.93	
24.07	46.72	67.25	81.09	95.05	121.50	-	
28.82	55.88	79.59	96.37	112.64	140.91	-	
30.49	59.11	83.90	101.71	118.78	147.57	-	
33.09	64.11	90.53	109.96	128.25	157.71	-	
37.64	72.66	102.43	124.31	143.57	-	-	

歯研平歯車

GROUND SPUR GEARS

モジュール
MODULE

3

圧力角 20° (並歯)
20° PRESSURE ANGLE FULL DEPTH TOOTH

歯部高周波焼き入れ HRC49 ~ 55
JIS B 1702-1 (ISO) 5 級
System of accuracy: JIS B1702-1(ISO) class 5

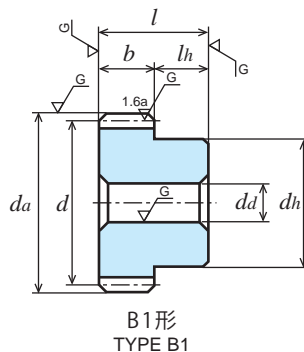

SCM435、440 クロムモリブデン鋼 (JIS G 4053)

Material : Chromium Molybdenum Steel (ISO 34CrMo4, 42CrMo4)

単位 : mm
Dimensions : mm

商品記号 Catalogue Number	歯数 Number of Teeth <i>z</i>	基準円直径 Reference Diameter <i>d</i>	歯先円直径 Tip Diameter <i>da</i>	形 Type	歯幅 Face Width <i>b</i>	穴径 Bore Diameter <i>da</i> (H7)	ハブ外径 Hub Diameter <i>dh</i>	ハブ長さ Hub Projection <i>lh</i>	全長 Overall Length <i>l</i>	重量 Weight <i>W</i> (kg)
SG3S 14B - 3015	14	φ 42	φ 48	B1	30	φ15	φ34	20	50	0.4
SG3S 15B - 3015	15	φ 45	φ 51	B1	30	φ15	φ36	20	50	0.5
SG3S 16B - 3015	16	φ 48	φ 54	B1	30	φ15	φ36	20	50	0.5
SG3S 18B - 3020	18	φ 54	φ 60	B1	30	φ20	φ45	20	50	0.7
SG3S 20B - 3020	20	φ 60	φ 66	B1	30	φ20	φ45	20	50	0.8
SG3S 24B - 3020	24	φ 72	φ 78	B1	30	φ20	φ50	20	50	1.1
SG3S 25B - 3020	25	φ 75	φ 81	B1	30	φ20	φ50	20	50	1.2
SG3S 28B - 3025	28	φ 84	φ 90	B1	30	φ25	φ60	20	50	1.6
SG3S 30B - 3025	30	φ 90	φ 96	B1	30	φ25	φ60	20	50	1.7
SG3S 32B - 3025	32	φ 96	φ102	B1	30	φ25	φ60	20	50	1.9
SG3S 35B - 3030	35	φ105	φ111	B1	30	φ30	φ70	20	50	2.3
SG3S 36B - 3030	36	φ108	φ114	B1	30	φ30	φ70	20	50	2.5

Gear tooth surface completed with induction hardening, Hardness HRC49 to 55.

許容伝達動力表 曲げ強さ (kW)

Allowable transfer capability table (kW) Bending Strength

歯数 <i>z</i>	歯幅 <i>b</i>	回転速度 (min ⁻¹) revolution/min						
		400	800	1,200	1,500	1,800	2,500	3,000
14	30	8.31	16.62	24.93	30.93	36.51	49.07	57.88
15	30	9.31	18.62	27.93	34.46	40.64	54.65	64.40
16	30	10.33	20.67	30.99	38.02	44.79	60.28	70.95
18	30	12.42	24.84	36.90	45.18	53.16	71.59	83.78
20	30	14.59	29.17	42.93	52.45	61.87	83.06	96.33
24	30	19.01	38.01	54.95	67.21	79.24	104.65	120.57
25	30	20.15	40.15	57.96	70.95	83.59	109.93	126.49
28	30	23.59	46.57	67.09	82.15	96.61	125.47	145.00
30	30	25.90	50.82	73.23	89.55	104.80	135.50	157.19
32	30	28.24	55.08	79.39	96.95	112.84	145.94	169.26
35	30	31.79	61.43	88.58	107.77	124.68	161.66	187.02
36	30	32.98	63.54	91.64	111.22	128.56	166.83	192.84

The above references are JGMA standard.

動力の換算式は P26 をご参照ください。Please refer to the conversion fomulas of power on page P26.

歯面強さ (kW)

Allowable transfer capability table (kW) Surface Durability

回転速度 (min ⁻¹) revolution/min						
400	800	1,200	1,500	1,800	2,500	3,000
1.81	3.68	5.60	7.02	8.36	11.43	13.62
2.08	4.25	6.47	8.06	9.59	13.13	15.64
2.38	4.86	7.40	9.17	10.91	14.95	17.78
3.04	6.21	9.38	11.61	13.79	18.92	22.39
3.78	7.73	11.59	14.32	17.06	23.34	27.37
5.52	11.31	16.68	20.65	24.60	33.13	38.59
6.01	12.28	18.09	22.41	26.69	35.79	41.64
7.60	15.42	22.69	28.14	33.45	44.30	51.76
8.77	17.71	26.08	32.30	38.21	50.39	59.08
10.03	20.15	29.69	36.74	43.23	57.01	66.83
12.09	24.10	35.54	43.81	51.24	67.75	79.19
12.82	25.49	37.60	46.25	54.04	71.51	83.51

歯研平歯車

GROUND SPUR GEARS

モジュール
MODULE

3

圧力角 20° (並歯)
20° PRESSURE ANGLE FULL DEPTH TOOTH

歯部高周波焼き入れ HRC49 ~ 55
JIS B 1702-1 (ISO) 5 級
System of accuracy: JIS B1702-1(ISO) class 5



御注文には必ず“フルネームで商品記号”を明記してください。
Please refer to the catalogue reference while ordering.

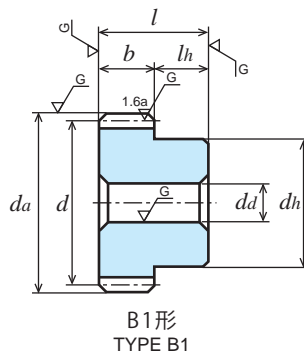

SCM435、440 クロムモリブデン鋼 (JIS G 4053)

Material : Chromium Molybdenum Steel (ISO 34CrMo4, 42CrMo4)

単位 : mm
Dimensions : mm

商品記号 Catalogue Number	歯数 Number of Teeth <i>z</i>	基準円直径 Reference Diameter <i>d</i>	歯先円直径 Tip Diameter <i>da</i>	形 Type	歯幅 Face Width <i>b</i>	穴径 Bore Diameter <i>da</i> (H7)	ハブ外径 Hub Diameter <i>dh</i>	ハブ長さ Hub Projection <i>lh</i>	全長 Overall Length <i>l</i>	重量 Weight <i>W</i> (kg)
SG3S 40B - 3030	40	φ120	φ126	B1	30	φ30	φ 70	20	50	3.0
SG3S 45B - 3030	45	φ135	φ141	B1	30	φ30	φ 80	20	50	3.9
SG3S 48B - 3030	48	φ144	φ150	B1	30	φ30	φ 80	20	50	4.3
SG3S 50B - 3030	50	φ150	φ156	B1	30	φ30	φ 80	20	50	4.6
SG3S 55B - 3035	55	φ165	φ171	B1	30	φ35	φ 90	20	50	5.6
SG3S 56B - 3035	56	φ168	φ174	B1	30	φ35	φ 90	20	50	5.8
SG3S 60B - 3035	60	φ180	φ186	B1	30	φ35	φ 90	20	50	6.6
SG3S 64B - 3040	64	φ192	φ198	B1	30	φ40	φ 90	20	50	7.3
SG3S 70B - 3040	70	φ210	φ216	B1	30	φ40	φ100	20	50	8.8
SG3S 72B - 3040	72	φ216	φ222	B1	30	φ40	φ100	20	50	9.3
SG3S 75B - 3040	75	φ225	φ231	B1	30	φ40	φ100	20	50	10.0
SG3S 80B - 3040	80	φ240	φ246	B1	30	φ40	φ100	20	50	11.3

Gear tooth surface completed with induction hardening, Hardness HRC49 to 55.

許容伝達動力表 曲げ強さ (kW)

Allowable transfer capability table (kW) Bending Strength

歯数 <i>z</i>	歯幅 <i>b</i>	回転速度 (min ⁻¹) revolution/min						
		400	800	1,200	1,500	1,800	2,500	3,000
40	30	37.79	71.94	103.77	124.77	143.76	187.16	214.00
45	30	43.83	82.62	118.23	141.06	162.71	211.59	236.20
48	30	47.47	89.00	126.51	150.58	174.29	224.14	248.74
50	30	49.77	93.24	131.94	156.80	181.90	231.80	256.76
55	30	55.48	103.74	145.22	173.05	200.54	250.00	-
56	30	56.62	105.82	147.83	176.30	204.19	253.49	-
60	30	61.14	114.10	158.07	189.13	218.62	266.97	-
64	30	65.63	122.26	168.12	201.71	232.50	-	-
70	30	72.29	133.62	184.00	220.08	249.18	-	-
72	30	74.50	137.34	189.20	226.08	254.51	-	-
75	30	77.78	142.85	196.93	234.96	262.28	-	-
80	30	83.22	151.85	209.58	247.54	274.71	-	-

歯面強さ (kW)

Allowable transfer capability table (kW) Surface Durability

回転速度 (min ⁻¹) revolution/min						
400	800	1,200	1,500	1,800	2,500	3,000
15.97	31.43	46.40	56.54	65.86	87.40	100.93
20.43	39.86	58.41	70.63	82.36	109.12	122.99
23.37	45.39	66.08	79.71	93.26	122.16	136.84
25.37	49.27	71.42	86.01	100.85	130.87	146.32
30.73	59.63	85.52	103.27	120.93	153.45	-
31.86	61.82	88.47	106.92	125.14	158.10	-
36.59	70.93	100.68	122.05	142.54	177.08	-
41.63	80.62	113.58	138.05	160.74	-	-
49.78	95.73	135.04	163.59	187.06	-	-
52.66	101.01	142.56	172.51	196.11	-	-
57.11	109.17	154.16	186.25	209.93	-	-
64.93	123.36	174.37	208.50	233.57	-	-

The above references are JGMA standard.

動力の換算式は P26 をご参照ください。Please refer to the conversion formulas of power on page P26.

目次 CONTENTS
インフォメーション INFORMATION
ギヤボックス GEAR BOXES
ノーバッキングギヤ ANTI BACKLASH SPUR GEARS
歯研平歯車 GROUND SPUR GEARS
平歯車 SPUR GEARS
内歯車 INTERNAL GEARS
歯研ラック GROUND RACKS
ラック RACKS
へリカル・スクリューギヤ HELICAL GEARS AND SCREW GEARS
ウォーム・ウォームギヤ WORMS AND WORM GEARS
かみ歯車 BEVEL GEARS
スプロケット SPROCKETS
技術資料 REFERENCE DATA

歯研平歯車の特徴 (SG シリーズ)

Feature of SG Ground Spur Gears.

- 1) サイズはモジュール m0.5 より m3.0 までの 7 サイズで豊富に品揃えしております。
- 2) 材質は SCM435、440 を用い、歯部高周波焼き入れ (HRC49 ~ 55) を行なっております。穴、ハブ部の追加加工が可能です。
- 3) 精度等級は JIS B 1702-1(ISO) 5 級になっております。
- 4) 穴・外周・側面・ハブ側面の研削仕上げを行なっております。追加加工時の基準面になります。
- 5) 両軸タイプ (ピニオン) も揃えております。

- 1) Size : Module 0.5 to 3.0 with wide range are available in seven sizes.
- 2) Material : Chromium Molybdenum Steel, complete with high frequency Induction Hardened. (HRC49 to 55).
- 3) System of accuracy: JIS B 1702-1(ISO) class 5.
- 4) Bore diameter, Tip diameter and other surfaces are ground so that chucking base can be performed when additional machining is required.
- 5) We have Ground Spur Gear with Solid shaft on both ends for Pinion, size ranging from M0.5 to 2.0.

歯研平歯車の追加加工時のご注意 (SG シリーズ)

Precaution for additional process of SG Ground Spur Gears.

KG 歯研平歯車は、なるべく穴を追加加工しないでご利用下さい。追加加工をしますと、歯車の精度が下がる事があります。但しご利用の際、追加加工が必要となりましたら次項にご注意下さい。

We provide high precision and high quality performance of KG Ground Spur Gears to customer. KG Ground Spur Gears do not require additional machining by our customer. This will therefore prevent deterioration of KG Ground Spur Gears, which has been vigorously checked by KG before delivery to customer.

However, due to your 'special' requirement that need additional machining to KG-Ground Spur Gear, please note the following information.

歯研平歯車の穴の追加加工のご注意 (SG シリーズ)

Precaution for additional machining to bore diameter of SG Ground Spur Gears.

- 1) 必ず生づめスクロールチャックを用いて チャッキングした商品の穴面から芯出しをして下さい。
- 2) 図のようにチャッキングすれば 外周と側面が研削面となっておりますので 容易に芯が出せます。
- 3) 外径の小さい (小歯数) 歯車は、穴面も焼き入れの影響で硬化しており、切削性が悪くなりますのでご注意下さい。
- 4) 追加加工による最大加工径は ハブ径の 60-70% を目安として下さい。

Additional machining for bore diameter is not advisable for our KG Ground Spur Gears.

Additional machining might be affected the precision class, as for the gear increased pitch deviation by additional key way process, may cause 1 or 2 class decline.

- 1) We recommend the use of three-jaw chuck (scroll chuck) that is not surface hardened for centering of the gear.
 - 2) The drawing shown on the right is highly recommended to follow, in order to obtain the centering easier because the gear has been ground.
 - 3) Due to induction hardening, the bore diameter of small size gears (Pinion) may not be easily machined.
 - 4) The maximum bore dimension should not exceed 60-70% of the hub diameter if additional machining is required.
- Machining will be easier if you follow the instruction (refer to the above picture).

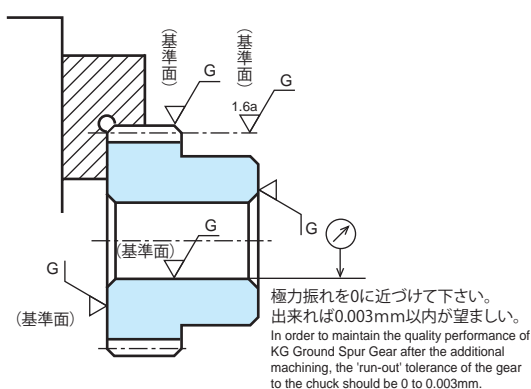

歯研平歯車のその他の部分の追加工の時のご注意 (SG シリーズ) Precaution for additional process for other parts of SG Ground Spur Gear.

- 1) チャッキング方法は穴の追加工と同じですが、ハブをチャッキングする場合も、必ず穴面からの芯出しを行なって下さい。
- 2) 両軸付き (L) 歯車の歯部に近い軸部は、熱処理による影響で硬化していますのでご注意ください。
- 3) 小モジュールで歯数の少ないものは、2) と同じく穴面まで硬化している事があります。
- 4) 歯部に近い部分は、熱処理の影響で硬化しておりますのでご注意ください。

- 1) Method of chucking is the same as in the boring process. Please take note of the centering location when chucking to the gear hub.
- 2) Due to the heat treatment, both sides of the solid shaft areas of the 'Type L' are low in machinability.
- 3) Heat treatment on specific surface of small module size gear for Pinion will affect the hardening of the whole gear module.
- 4) Take note that surface near to the gear tooth area may be low machinability due to the heat treatment processed.

特殊仕様の歯研歯車も受注致しております Customize make Ground Gears.

歯車の種類	平歯車、はすば歯車
モジュールサイズ	m : 0.3 0.4 0.5 0.6 0.75 0.8 1.0 1.25 1.5 1.75 2.0 2.25 2.5 2.75 3.0 4.0 5.0
DP (インチ) サイズ	ご相談により受け賜ります。
歯数	10 枚より 500 枚まで
外径	φ8mm より φ350mm まで
歯幅	最大 200mm まで
最大ネジレ角	左右 45°
保証精度等級	新 JIS 4 級 (旧 JIS 0 級) より受け賜ります。

Our gear products: Spur, Helical and other gears.
 Our sizes: Module from 0.3, 0.4, 0.5, 0.6, 0.75, 0.8, 1.0, 1.25, 1.5, 1.75, 2.0, 2.25, 2.5, 2.75, 3.0, 4.0 and 5.0.
 Our capability of D.P (inch) size: Please provide your drawing to us. Price, delivery and lead-time are negotiable. Do not hesitate to contact us for discussion.

Number of teeth and maximum tip diameter.
 No. of teeth: range from 10z to 500z
 Tip diameter: $d_a=8.0\text{mm}$ up to 350.00mm
 Face width: Maximum 200.0mm
 Helix: Maximum 45 degree (Right /Left helix)
 We are able to fabricate gears with standard that are above JIS B 1702 class 0 equivalent ISO 4.

Memo

目次
CONTENTS

インフォメーション
INFORMATION

ギヤボックス
GEAR BOXES

ノーバックス
ANTI BACKLASH SPUR GEARS

歯研平歯車
GROUND SPUR GEARS

平歯車
SPUR GEARS

内歯車
INTERNAL GEARS

歯研ラック
GROUND RACKS

ラック
RACKS

ヘリカル・スクリューギヤ
HELICAL GEARS AND SCREW GEARS

ウォーム
WORMS AND WORM WHEELS

かさ歯車
BEVEL GEARS

スプロケット
SPURKETS

技術資料
REFERENCE DATA

歯研平歯車

GROUND SPUR GEARS

モジュール **0.5** 圧力角 20° (並歯)
 MODULE 20° PRESSURE ANGLE FULL DEPTH TOOTH

歯部高周波焼き入れ Hrc47 ~ 53
 JIS B 1702-1 (ISO) 7級
 System of accuracy : JIS B 1702-1(ISO) class 7



御注文には必ず“フルネームで商品記号”を明記してください。
 Please refer to the catalogue reference while ordering.

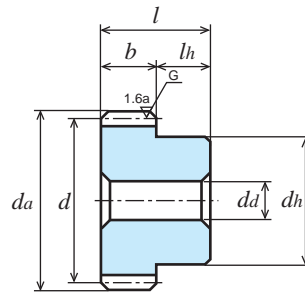

B1形
TYPE B1

S45C 機械構造用炭素鋼 (JIS G 4051)

Material : Carbon Steel (ISO C45)

単位 : mm
Dimensions : mm

商品記号 Catalogue Number	歯数 Number of Teeth <i>z</i>	基準円直径 Reference Diameter <i>d</i>	歯先円直径 Tip Diameter <i>da</i>	形 Type	歯幅 Face Width <i>b</i>	穴径 Bore Diameter <i>da</i> (H7)	ハブ外径 Hub Diameter <i>dh</i>	ハブ長さ Hub Projection <i>lh</i>	全長 Overall Length <i>l</i>	重量 Weight <i>W</i> (g)
● SGE50S 30B - 0504	30	φ15	φ16	B1	5	φ4	φ12	8	13	12.7
● SGE50S 40B - 0504	40	φ20	φ21	B1	5	φ4	φ15	8	13	22.1
● SGE50S 50B - 0504	50	φ25	φ26	B1	5	φ4	φ18	8	13	33.9
● SGE50S 60B - 0505	60	φ30	φ31	B1	5	φ5	φ22	8	13	49.5
● SGE50S 70B - 0505	70	φ35	φ36	B1	5	φ5	φ25	8	13	66.5
● SGE50S 80B - 0506	80	φ40	φ41	B1	5	φ6	φ28	8	13	85.0
● SGE50S 90B - 0506	90	φ45	φ46	B1	5	φ6	φ32	8	13	109.9
● SGE50S 100B - 0506	100	φ50	φ51	B1	5	φ6	φ35	8	13	134.4
● SGE50S 120B - 0506	120	φ60	φ61	B1	5	φ6	φ42	8	13	194.9

● の商品は新商品です。
 Products with ● marks are new item.

Gear tooth surface completed with induction hardening, Hardness HRC47 to 53.

許容伝達動力表 曲げ強さ (W)

Allowable transfer capability table (W) Bending Strength

歯数 <i>z</i>	歯幅 <i>b</i>	回転速度 (min ⁻¹) revolution/min						
		400	800	1,200	1,500	1,800	2,500	3,000
30	5	80.54	161.08	241.63	296.60	347.96	459.16	531.69
40	5	117.09	234.19	342.60	415.43	484.22	630.05	727.71
50	5	154.49	307.53	438.50	528.52	612.15	795.67	929.77
60	5	192.53	375.41	530.54	635.73	732.48	965.31	1,123.08
70	5	230.93	441.27	618.60	737.06	855.34	1,128.41	1,315.49
80	5	269.57	505.05	702.44	837.49	979.47	1,288.25	1,505.79
90	5	308.09	566.09	781.45	941.83	1,098.54	1,448.09	1,687.94
100	5	345.37	625.52	862.40	1,044.07	1,214.70	1,604.66	1,865.27
120	5	414.57	738.59	1,029.96	1,240.25	1,447.40	1,904.73	2,221.44

The above references are JGMA standard.

動力の換算式は P26 をご参照ください。Please refer to the conversion formulas of power on page P26.

歯面強さ (W)

Allowable transfer capability table (W) Surface Durability

回転速度 (min ⁻¹) revolution/min							
400	800	1,200	1,500	1,800	2,500	3,000	
23.40	48.25	73.71	91.38	108.03	144.51	168.88	
42.74	88.14	131.25	160.74	188.91	249.31	290.12	
68.24	140.01	203.27	247.30	288.79	380.74	448.75	
100.00	200.97	289.16	349.83	406.41	543.35	637.24	
138.12	272.07	388.19	467.15	546.46	731.33	859.50	
182.72	352.81	499.54	601.50	709.14	945.96	1,114.64	
233.83	442.88	622.34	757.42	890.63	1,190.99	1,399.33	
290.20	541.88	760.46	929.62	1,090.21	1,461.16	1,712.07	
416.54	765.05	1,085.93	1,320.47	1,553.44	2,073.87	2,437.97	

目次
CONTENTS

インフォメーション
INFORMATION

ギヤボックス
GEAR BOXES

ノーバックラッシュギヤ
ANTI BACKLASH SPUR GEARS

歯研平歯車
GROUND SPUR GEARS

平歯車
SPUR GEARS

内歯車
INTERNAL GEARS

歯用ラック
GROUND RACKS

ラック
RACKS

へリカル・スクリューギヤ
HELICAL GEARS AND SCREW GEARS

ウォーム・ウォームギヤ
WORMS AND WORM GEARS

かさ歯車
BEVEL GEARS

スプロケット
SPROCKETS

技術資料
REFERENCE DATA

歯研平歯車

GROUND SPUR GEARS

モジュール **0.8** 圧力角 20° (並歯)
 MODULE 20° PRESSURE ANGLE FULL DEPTH TOOTH

歯部高周波焼き入れ HRC47 ~ 53
 JIS B 1702-1 (ISO) 7級
 System of accuracy : JIS B 1702-1(ISO) class 7

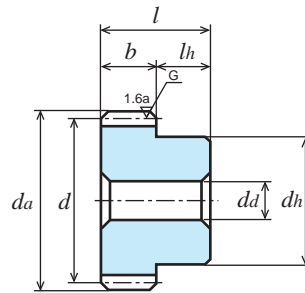

B1形
TYPE B1

S45C 機械構造用炭素鋼 (JIS G 4051)

Material : Carbon Steel (ISO C45)

単位 : mm
Dimensions : mm

商品記号 Catalogue Number	歯数 Number of Teeth <i>z</i>	基準円直径 Reference Diameter <i>d</i>	歯先円直径 Tip Diameter <i>da</i>	形 Type	歯幅 Face Width <i>b</i>	穴径 Bore Diameter <i>di</i> (H7)	ハブ外径 Hub Diameter <i>dh</i>	ハブ長さ Hub Projection <i>lh</i>	全長 Overall Length <i>l</i>	重量 Weight <i>W</i> (g)
● SGE80S 25B - 0805	25	φ20	φ21.6	B1	8	φ 5	φ16	10	18	32.5
● SGE80S 30B - 0805	30	φ24	φ25.6	B1	8	φ 5	φ20	10	18	50.1
● SGE80S 40B - 0806	40	φ32	φ33.6	B1	8	φ 6	φ25	10	18	84.7
● SGE80S 50B - 0806	50	φ40	φ41.6	B1	8	φ 6	φ28	10	18	122.9
● SGE80S 60B - 0806	60	φ48	φ49.6	B1	8	φ 6	φ34	10	18	180.5
● SGE80S 70B - 0808	70	φ56	φ57.6	B1	8	φ 8	φ40	10	18	245.7
● SGE80S 80B - 0808	80	φ64	φ65.6	B1	8	φ 8	φ45	10	18	319.2
● SGE80S 90B - 0808	90	φ72	φ73.6	B1	8	φ 8	φ50	10	18	402.1
● SGE80S 100B - 0810	100	φ80	φ81.6	B1	8	φ10	φ60	10	18	525.8
● SGE80S 120B - 0810	120	φ96	φ97.6	B1	8	φ10	φ70	10	18	744.7

● の商品は新商品です。
 Products with ● marks are new item.

Gear tooth surface completed with induction hardening, Hardness HRC47 to 53.

許容伝達動力表 曲げ強さ (W)

Allowable transfer capability table (W) Bending Strength

歯数 <i>z</i>	歯幅 <i>b</i>	回転速度 (min ⁻¹) revolution/min						
		400	800	1,200	1,500	1,800	2,500	3,000
25	8	257.23	514.46	752.38	912.43	1,063.43	1,383.75	1,598.07
30	8	329.81	659.29	941.65	1,136.20	1,317.84	1,707.70	1,997.37
40	8	479.71	927.82	1,307.05	1,562.49	1,797.72	2,380.47	2,765.49
50	8	632.84	1,185.57	1,648.92	1,966.00	2,299.31	3,024.09	3,534.52
60	8	788.13	1,432.30	1,970.04	2,387.61	2,780.45	3,670.23	4,270.98
70	8	929.75	1,667.30	2,314.57	2,792.93	3,250.73	4,290.73	4,995.68
80	8	1,067.88	1,890.71	2,647.87	3,183.03	3,723.73	4,896.66	5,706.20
90	8	1,200.89	2,101.81	2,966.46	3,579.91	4,176.82	5,493.79	6,382.94
100	8	1,331.42	2,334.79	3,277.69	3,969.25	4,619.06	6,077.09	7,106.74
120	8	1,581.73	2,784.19	3,915.35	4,716.56	5,495.21	7,256.77	8,708.13

The above references are JGMA standard.

動力の換算式は P26 をご参照ください。Please refer to the conversion fomulas of power on page P26.

歯面強さ (W)

Allowable transfer capability table (W) Surface Durability

回転速度 (min ⁻¹) revolution/min							
400	800	1,200	1,500	1,800	2,500	3,000	
68.40	141.06	210.02	257.25	302.18	398.84	464.43	
100.25	206.60	300.37	365.97	427.76	562.45	663.17	
183.16	365.19	523.66	632.11	733.20	984.91	1,153.54	
292.33	564.56	799.31	962.34	1,134.54	1,513.68	1,783.55	
428.08	801.96	1,122.84	1,374.15	1,613.15	2,160.32	2,533.88	
581.53	1,074.99	1,519.00	1,851.10	2,171.74	2,907.99	3,413.28	
756.77	1,381.16	1,969.08	2,390.32	2,818.63	3,760.20	4,417.24	
953.11	1,719.57	2,470.54	3,010.83	3,540.97	4,725.01	5,533.69	
1,169.89	2,114.84	3,022.20	3,695.86	4,335.34	5,786.57	6,821.14	
1,661.95	3,015.64	4,316.82	5,251.26	6,167.25	8,262.29	9,994.37	

齒研平齒車

GROUND SPUR GEARS

モジュール
MODULE

1

圧力角 20° (並歯)
20° PRESSURE ANGLE FULL DEPTH TOOTH

歯部高周波焼き入れ HRC47 ~ 53
JIS B 1702-1 (ISO) 7級
System of accuracy : JIS B 1702-1(ISO) class 7



御注文には必ず“フルネームで商品記号”を明記してください。
Please refer to the catalogue reference while ordering.

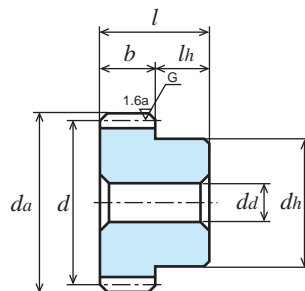

B1形
TYPE B1

S45C 機械構造用炭素鋼 (JIS G 4051)

Material : Carbon Steel (ISO C45)

単位 : mm
Dimensions : mm

商品記号 Catalogue Number	歯数 Number of Teeth z	基準円直径 Reference Diameter d	歯先円直径 Tip Diameter da	形 Type	歯幅 Face Width b	穴径 Bore Diameter da(H7)	ハブ外径 Hub Diameter dh	ハブ長さ Hub Projection lh	全長 Overall Length l	重量 Weight W(g)
● SGE1S 20B - 1005	20	φ 20	φ 22	B1	10	φ 5	φ 16	10	20	37.0
● SGE1S 25B - 1005	25	φ 25	φ 27	B1	10	φ 5	φ 20	10	20	59.7
● SGE1S 30B - 1006	30	φ 30	φ 32	B1	10	φ 6	φ 25	10	20	89.1
● SGE1S 40B - 1006	40	φ 40	φ 42	B1	10	φ 6	φ 30	10	20	149.1
● SGE1S 50B - 1008	50	φ 50	φ 52	B1	10	φ 8	φ 35	10	20	221.0
● SGE1S 60B - 1008	60	φ 60	φ 62	B1	10	φ 8	φ 42	10	20	321.9
● SGE1S 70B - 1010	70	φ 70	φ 72	B1	10	φ 10	φ 55	10	20	442.9
● SGE1S 80B - 1010	80	φ 80	φ 82	B1	10	φ 10	φ 60	10	20	603.1
● SGE1S 90B - 1010	90	φ 90	φ 92	B1	10	φ 10	φ 65	10	20	746.3
● SGE1S 100B - 1010	100	φ 100	φ 102	B1	10	φ 10	φ 70	10	20	904.9
● SGE1S 120B - 1010	120	φ 120	φ 122	B1	10	φ 10	φ 90	10	20	1373.2

●の商品は新商品です。
Products with ● marks are new item.

Gear tooth surface completed with induction hardening, Hardness HRC47 to 53.

許容伝達動力表 曲げ強さ (kW)

Allowable transfer capability table (kW) Bending Strength

歯数 z	歯幅 b	回転速度 (min ⁻¹) revolution/min						
		400	800	1,200	1,500	1,800	2,500	3,000
20	10	0.37	0.73	1.07	1.30	1.51	1.96	2.27
25	10	0.50	1.00	1.43	1.72	1.99	2.59	3.02
30	10	0.64	1.26	1.78	2.13	2.45	3.23	3.76
40	10	0.94	1.76	2.44	2.91	3.40	4.48	5.23
50	10	1.23	2.23	3.07	3.72	4.33	5.72	6.64
60	10	1.50	2.68	3.73	4.49	5.24	6.90	8.05
70	10	1.77	3.10	4.36	5.26	6.14	8.08	9.39
80	10	2.02	3.54	4.97	6.02	7.01	9.22	10.78
90	10	2.26	3.98	5.59	6.75	7.85	10.31	12.32
100	10	2.50	4.41	6.20	7.46	8.70	11.57	13.88
120	10	2.95	5.23	7.37	8.89	10.32	14.17	17.01

The above references are JGMA standard.

動力の換算式は P26 をご参照ください。Please refer to the conversion formulas of power on page P26.

歯面強さ (kW)

Allowable transfer capability table (kW) Surface Durability

回転速度 (min ⁻¹) revolution/min							
400	800	1,200	1,500	1,800	2,500	3,000	
0.09	0.18	0.26	0.32	0.38	0.50	0.58	
0.14	0.28	0.41	0.49	0.58	0.76	0.90	
0.20	0.40	0.58	0.70	0.81	1.09	1.27	
0.37	0.71	1.00	1.20	1.42	1.89	2.23	
0.58	1.08	1.52	1.86	2.18	2.92	3.42	
0.83	1.53	2.17	2.64	3.11	4.15	4.88	
1.13	2.04	2.93	3.56	4.19	5.59	6.56	
1.46	2.64	3.78	4.62	5.42	7.23	8.53	
1.84	3.33	4.76	5.80	6.80	9.05	10.91	
2.25	4.08	5.84	7.10	8.34	11.25	13.61	
3.17	5.79	8.30	10.10	11.83	16.48	19.94	

目次
CONTENTS

インフォメーション
INFORMATION

ギヤボックス
GEAR BOXES

ノーバックラッシュギヤ
ANTI BACKLASH SPUR GEARS

歯研平歯車
GROUND SPUR GEARS

平歯車
SPUR GEARS

内歯車
INTERNAL GEARS

歯研ラック
GROUND RACKS

ラック
RACKS

ハニカム・スクリューギヤ
HELICAL GEARS AND SCREW GEARS

ウォーム・ウォームホイール
WORMS AND WORM WHEELS

かさ歯車
BEVEL GEARS

スプロケット
SPROCKETS

技術仕様
REFERENCE DATA

歯研平歯車

GROUND SPUR GEARS

モジュール **1.5** 圧力角 20° (並歯)
 MODULE 20° PRESSURE ANGLE FULL DEPTH TOOTH

歯部高周波焼き入れ HRC47 ~ 53
 JIS B 1702-1 (ISO) 7級
 System of accuracy : JIS B 1702-1(ISO) class 7

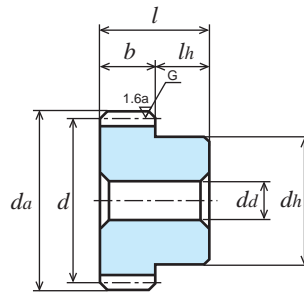

B1形
TYPE B1

S45C 機械構造用炭素鋼 (JIS G 4051)

Material : Carbon Steel (ISO C45)

単位 : mm
Dimensions : mm

商品記号 Catalogue Number	歯数 Number of Teeth <i>z</i>	基準円直径 Reference Diameter <i>d</i>	歯先円直径 Tip Diameter <i>da</i>	形 Type	歯幅 Face Width <i>b</i>	穴径 Bore Diameter <i>di</i> (H7)	ハブ外径 Hub Diameter <i>dh</i>	ハブ長さ Hub Projection <i>lh</i>	全長 Overall Length <i>l</i>	重量 Weight <i>W</i> (kg)
● SGE1.5S 20B - 1506	20	φ 30	φ 33	B1	15	φ 6	φ 25	15	30	0.1
● SGE1.5S 25B - 1508	25	φ 37.5	φ 40.5	B1	15	φ 8	φ 30	15	30	0.2
● SGE1.5S 30B - 1508	30	φ 45	φ 48	B1	15	φ 8	φ 38	15	30	0.3
● SGE1.5S 40B - 1508	40	φ 60	φ 63	B1	15	φ 8	φ 50	15	30	0.6
● SGE1.5S 50B - 1510	50	φ 75	φ 78	B1	15	φ 10	φ 60	15	30	0.8
● SGE1.5S 60B - 1510	60	φ 90	φ 93	B1	15	φ 10	φ 65	15	30	1.1
● SGE1.5S 70B - 1510	70	φ 105	φ 108	B1	15	φ 10	φ 75	15	30	1.5
● SGE1.5S 80B - 1510	80	φ 120	φ 123	B1	15	φ 10	φ 85	15	30	2.0
● SGE1.5S 90B - 1512	90	φ 135	φ 138	B1	15	φ 12	φ 95	15	30	2.5
● SGE1.5S 100B - 1515	100	φ 150	φ 153	B1	15	φ 15	φ 105	15	30	3.1

● の商品は新商品です。
 Products with ● marks are new item.

Gear tooth surface completed with induction hardening, Hardness HRC47 to 53.

許容伝達動力表 曲げ強さ (kW)

Allowable transfer capability table (kW) Bending Strength

歯数 <i>z</i>	歯幅 <i>b</i>	回転速度 (min ⁻¹) revolution/min						
		400	800	1,200	1,500	1,800	2,500	3,000
20	15	1.23	2.40	3.40	4.07	4.69	6.18	7.19
25	15	1.70	3.21	4.48	5.32	6.22	8.18	9.56
30	15	2.17	3.99	5.51	6.65	7.75	10.22	11.91
40	15	3.08	5.49	7.66	9.22	10.76	14.16	16.52
50	15	3.95	6.91	9.73	11.76	13.71	18.04	20.93
60	15	4.78	8.39	11.80	14.24	16.56	21.74	25.99
70	15	5.57	9.82	13.82	16.63	19.38	25.98	31.17
80	15	6.32	11.19	15.77	19.01	22.09	30.33	36.39
90	15	7.03	12.59	17.67	21.29	24.95	34.66	41.59
100	15	7.76	13.95	19.58	23.51	28.11	39.04	46.85

歯面強さ (kW)

Allowable transfer capability table (kW) Surface Durability

回転速度 (min ⁻¹) revolution/min						
400	800	1,200	1,500	1,800	2,500	3,000
0.30	0.60	0.87	1.05	1.22	1.63	1.91
0.48	0.93	1.33	1.59	1.88	2.50	2.95
0.70	1.33	1.87	2.27	2.67	3.57	4.20
1.25	2.30	3.26	3.96	4.66	6.22	7.62
1.94	3.49	5.01	6.11	7.18	9.58	11.21
2.75	4.99	7.14	8.70	10.20	13.58	16.37
3.70	6.72	9.63	11.70	13.75	18.69	22.61
4.76	8.68	12.45	15.16	17.75	24.73	29.91
5.93	10.93	15.62	19.01	22.46	31.65	38.28
7.24	13.42	19.16	23.24	28.01	39.46	47.73

The above references are JGMA standard.

動力の換算式は P26 をご参照ください。Please refer to the conversion formulas of power on page P26.

歯研平歯車

GROUND SPUR GEARS

モジュール
MODULE

2

圧力角 20° (並歯)
20° PRESSURE ANGLE FULL DEPTH TOOTH

歯部高周波焼き入れ HRC47 ~ 53
JIS B 1702-1 (ISO) 7級
System of accuracy : JIS B 1702-1(ISO) class 7



御注文には必ず“フルネームで商品記号”を明記してください。
Please refer to the catalogue reference while ordering.

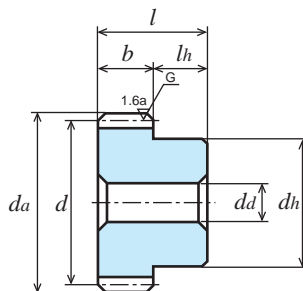

B1形
TYPE B1

S45C 機械構造用炭素鋼 (JIS G 4051)

Material : Carbon Steel (ISO C45)

単位 : mm
Dimensions : mm

商品記号 Catalogue Number	歯数 Number of Teeth <i>z</i>	基準円直径 Reference Diameter <i>d</i>	歯先円直径 Tip Diameter <i>da</i>	形 Type	歯幅 Face Width <i>b</i>	穴径 Bore Diameter <i>da'(H7)</i>	ハブ外径 Hub Diameter <i>dh</i>	ハブ長さ Hub Projection <i>lh</i>	全長 Overall Length <i>l</i>	重量 Weight <i>W(kg)</i>
● SGE2S 20B - 2008	20	φ 40	φ 44	B1	20	φ 8	φ 34	20	40	0.3
● SGE2S 25B - 2008	25	φ 50	φ 54	B1	20	φ 8	φ 40	20	40	0.5
● SGE2S 30B - 2010	30	φ 60	φ 64	B1	20	φ 10	φ 50	20	40	0.7
● SGE2S 40B - 2010	40	φ 80	φ 84	B1	20	φ 10	φ 60	20	40	1.2
● SGE2S 50B - 2012	50	φ 100	φ 104	B1	20	φ 12	φ 70	20	40	1.8
● SGE2S 60B - 2012	60	φ 120	φ 124	B1	20	φ 12	φ 85	20	40	2.6
● SGE2S 70B - 2015	70	φ 140	φ 144	B1	20	φ 15	φ 100	20	40	3.6
● SGE2S 80B - 2015	80	φ 160	φ 164	B1	20	φ 15	φ 115	20	40	4.7
● SGE2S 90B - 2015	90	φ 180	φ 184	B1	20	φ 15	φ 130	20	40	6.0
● SGE2S 100B - 2015	100	φ 200	φ 204	B1	20	φ 15	φ 140	20	40	7.3

● の商品は新商品です。
Products with ● marks are new item.

Gear tooth surface completed with induction hardening, Hardness HRC47 to 53.

許容伝達動力表 曲げ強さ (kW)

Allowable transfer capability table (kW) Bending Strength

歯数 <i>z</i>	歯幅 <i>b</i>	回転速度 (min ⁻¹) revolution/min						
		400	800	1,200	1,500	1,800	2,500	3,000
20	20	2.92	5.47	7.61	9.07	10.61	13.96	16.31
25	20	4.00	7.25	9.99	12.09	14.07	18.59	21.61
30	20	5.02	8.95	12.48	15.03	17.54	23.09	26.92
40	20	7.02	12.31	17.28	20.93	24.36	32.05	37.48
50	20	8.91	15.70	22.09	26.58	30.99	41.20	49.44
60	20	10.70	18.94	26.69	32.18	37.39	51.34	61.60
70	20	12.39	22.24	31.22	37.57	44.34	61.58	73.89
80	20	14.17	25.43	35.66	43.13	51.76	71.89	86.27
90	20	15.92	28.48	39.89	49.29	59.15	82.16	98.59
100	20	17.63	31.51	44.42	55.52	66.63	92.54	111.04

The above references are JGMA standard.

動力の換算式は P26 をご参照ください。Please refer to the conversion formulas of power on page P26.

歯面強さ (kW)

Allowable transfer capability table (kW) Surface Durability

回転速度 (min ⁻¹) revolution/min						
400	800	1,200	1,500	1,800	2,500	3,000
0.73	1.41	2.00	2.41	2.84	3.78	4.46
1.16	2.17	3.04	3.72	4.36	5.84	6.85
1.67	3.06	4.34	5.28	6.21	8.30	9.75
2.92	5.29	7.56	9.24	10.84	14.47	17.05
4.49	8.16	11.68	14.19	16.68	22.50	27.22
6.34	11.57	16.60	20.21	23.67	32.97	39.88
8.45	15.65	22.36	27.17	32.32	45.53	55.08
10.96	20.27	28.94	35.34	42.75	60.23	72.86
13.79	25.42	36.25	45.23	54.71	77.09	93.25
16.91	31.14	44.68	56.40	68.23	96.13	116.29

目次
CONTENTS

インフォメーション
INFORMATION

ギヤボックス
GEAR BOXES

ノーバッキングギヤ
ANTI BACKLASH SPUR GEARS

歯研平歯車
GROUND SPUR GEARS

平歯車
SPUR GEARS

内歯車
INTERNAL GEARS

歯研ラック
GROUND RACKS

ラック
RACKS

へリカル・スプリングギヤ
HELICAL GEARS AND SCREW GEARS

ウォーム・ウォームホイール
WORMS AND WORM WHEELS

かさ歯車
BEVEL GEARS

スプロケット
SPROCKETS

技術資料
REFERENCE DATA

歯研平歯車

GROUND SPUR GEARS

モジュール **2.5** 圧力角 20° (並歯)
 MODULE 2.5 20° PRESSURE ANGLE FULL DEPTH TOOTH

歯部高周波焼き入れ HRC47 ~ 53
 JIS B 1702-1 (ISO) 7級
 System of accuracy : JIS B 1702-1(ISO) class 7

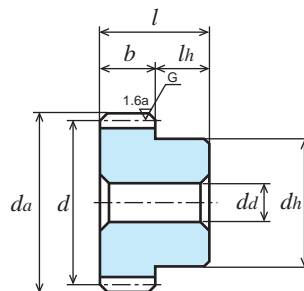

B1形
TYPE B1

S45C 機械構造用炭素鋼 (JIS G 4051)

Material : Carbon Steel (ISO C45)

単位 : mm
Dimensions : mm

商品記号 Catalogue Number	歯数 Number of Teeth <i>z</i>	基準円直径 Reference Diameter <i>d</i>	歯先円直径 Tip Diameter <i>da</i>	形 Type	歯幅 Face Width <i>b</i>	穴径 Bore Diameter <i>di</i> (H7)	ハブ外径 Hub Diameter <i>dh</i>	ハブ長さ Hub Projection <i>lh</i>	全長 Overall Length <i>l</i>	重量 Weight <i>W</i> (kg)
● SGE2.5S 20B - 2510	20	φ 50	φ 55	B1	25	φ10	φ 42	20	45	0.6
● SGE2.5S 25B - 2510	25	φ 62.5	φ 67.5	B1	25	φ10	φ 52	20	45	0.9
● SGE2.5S 30B - 2512	30	φ 75	φ 80	B1	25	φ12	φ 65	20	45	1.3
● SGE2.5S 40B - 2512	40	φ100	φ105	B1	25	φ12	φ 70	20	45	2.1
● SGE2.5S 50B - 2515	50	φ125	φ130	B1	25	φ15	φ 90	20	45	3.3
● SGE2.5S 60B - 2515	60	φ150	φ155	B1	25	φ15	φ105	20	45	4.8
● SGE2.5S 70B - 2520	70	φ175	φ180	B1	25	φ20	φ125	20	45	6.5
● SGE2.5S 80B - 2520	80	φ200	φ205	B1	25	φ20	φ140	20	45	8.5

●の商品は新商品です。
 Products with ● marks are new item.

Gear tooth surface completed with induction hardening, Hardness HRC47 to 53.

許容伝達動力表 曲げ強さ (kW)

Allowable transfer capability table (kW) Bending Strength

歯数 <i>z</i>	歯幅 <i>b</i>	回転速度 (min ⁻¹) revolution/min						
		400	800	1,200	1,500	1,800	2,500	3,000
20	25	5.68	10.28	14.18	17.16	19.97	26.38	30.67
25	25	7.61	13.51	18.89	22.72	26.56	34.93	40.73
30	25	9.52	16.68	23.49	28.39	33.09	43.52	50.51
40	25	13.20	23.25	32.71	39.35	45.89	61.00	73.20
50	25	16.62	29.53	41.53	50.10	58.15	80.47	96.56
60	25	19.94	35.84	50.29	60.38	72.19	100.27	120.32
70	25	23.40	41.90	58.71	72.16	86.59	120.27	144.32
80	25	26.76	47.82	67.40	84.25	101.10	140.41	168.49

The above references are JGMA standard.

動力の換算式は P26 をご参照ください。Please refer to the conversion fomulas of power on page P26.

歯面強さ (kW)

Allowable transfer capability table (kW) Surface Durability

回転速度 (min ⁻¹) revolution/min							
400	800	1,200	1,500	1,800	2,500	3,000	
1.45	2.71	3.80	4.65	5.45	7.31	8.56	
2.26	4.13	5.88	7.14	8.41	11.22	13.19	
3.23	5.82	8.35	10.19	11.97	15.97	18.69	
5.61	10.20	14.60	17.74	20.86	28.13	34.02	
8.56	15.67	22.43	27.33	31.97	44.89	54.30	
12.07	22.36	31.94	38.73	46.68	65.77	79.56	
16.31	30.11	42.94	53.30	64.47	90.84	109.88	
21.13	38.93	55.85	70.50	85.28	120.17	145.36	

歯研平歯車

GROUND SPUR GEARS

モジュール
MODULE

3

圧力角 20° (並歯)
20° PRESSURE ANGLE FULL DEPTH TOOTH

歯部高周波焼き入れ HRC47 ~ 53
JIS B 1702-1 (ISO) 7級
System of accuracy : JIS B 1702-1(ISO) class 7



御注文には必ず“フルネームで商品記号”を明記してください。
Please refer to the catalogue reference while ordering.

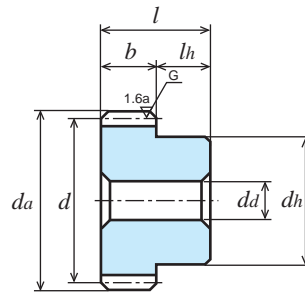

B1形
TYPE B1

S45C 機械構造用炭素鋼 (JIS G 4051)

Material : Carbon Steel (ISO C45)

単位 : mm
Dimensions : mm

商品記号 Catalogue Number	歯数 Number of Teeth <i>z</i>	基準円直径 Reference Diameter <i>d</i>	歯先円直径 Tip Diameter <i>da</i>	形 Type	歯幅 Face Width <i>b</i>	穴径 Bore Diameter <i>da(H7)</i>	ハブ外径 Hub Diameter <i>dh</i>	ハブ長さ Hub Projection <i>lh</i>	全長 Overall Length <i>l</i>	重量 Weight <i>W(kg)</i>
● SGE3S 20B - 3012	20	φ 60	φ 66	B1	30	φ12	φ 52	20	50	0.9
● SGE3S 25B - 3012	25	φ 75	φ 81	B1	30	φ12	φ 60	20	50	1.4
● SGE3S 30B - 3012	30	φ 90	φ 96	B1	30	φ12	φ 75	20	50	2.1
● SGE3S 40B - 3015	40	φ120	φ126	B1	30	φ15	φ 85	20	50	3.5
● SGE3S 50B - 3015	50	φ150	φ156	B1	30	φ15	φ105	20	50	5.4
● SGE3S 60B - 3015	60	φ180	φ186	B1	30	φ15	φ130	20	50	8.0
● SGE3S 70B - 3020	70	φ210	φ216	B1	30	φ20	φ150	20	50	10.8
● SGE3S 80B - 3020	80	φ240	φ246	B1	30	φ20	φ170	20	50	14.1

●の商品は新商品です。
Products with ● marks are new item.

Gear tooth surface completed with induction hardening, Hardness HRC47 to 53.

許容伝達動力表 曲げ強さ (kW)

Allowable transfer capability table (kW) Bending Strength

歯数 <i>z</i>	歯幅 <i>b</i>	回転速度 (min ⁻¹) revolution/min						
		400	800	1,200	1,500	1,800	2,500	3,000
20	30	9.61	17.12	23.88	28.75	33.56	44.16	51.50
25	30	12.83	22.47	31.65	38.25	44.59	58.65	68.07
30	30	15.98	28.09	39.47	47.64	55.43	72.74	86.96
40	30	21.97	38.89	54.81	66.08	76.77	105.40	126.48
50	30	27.65	49.70	69.74	83.74	100.12	139.05	166.86
60	30	33.58	60.06	84.13	103.96	124.75	173.26	207.92
70	30	39.28	70.25	99.75	124.69	149.63	207.82	249.39
80	30	44.76	80.24	116.46	145.58	174.69	242.63	291.15

The above references are JGMA standard.

動力の換算式は P26 をご参照ください。Please refer to the conversion formulas of power on page P26.

歯面強さ (kW)

Allowable transfer capability table (kW) Surface Durability

回転速度 (min ⁻¹) revolution/min							
400	800	1,200	1,500	1,800	2,500	3,000	
2.50	4.59	6.52	7.92	9.32	12.44	14.63	
3.87	6.99	10.02	12.23	14.36	19.17	22.43	
5.51	9.98	14.28	17.40	20.40	27.16	32.74	
9.51	17.36	24.90	30.31	35.50	49.45	59.82	
14.48	26.84	38.33	46.48	56.01	78.92	95.47	
20.68	38.13	54.37	67.85	82.07	115.64	139.88	
27.86	51.36	74.24	93.71	113.35	159.72	193.20	
35.97	66.47	98.20	123.96	149.95	211.28	255.57	

目次
CONTENTS

インフォメーション
INFORMATION

ギヤボックス
GEAR BOXES

ノーバッキングギヤ
ANTI BACKLASH SPUR GEARS

歯研平歯車
GROUND SPUR GEARS

平歯車
SPUR GEARS

内歯車
INTERNAL GEARS

歯ラック
GROUND RACKS

ラック
RACKS

へリカル・スクリューギヤ
HELICAL GEARS AND SCREW GEARS

ウォーム・ウォームギヤ
WORMS AND WORM GEARS

かさ歯車
BEVEL GEARS

スプロケット
SPROCKETS

技術仕様
REFERENCE DATA

Memo

目次
CONTENTS

インフォメーション
INFORMATION

ギヤボックス
GEAR BOXES

ノーバックス
ANTI BACKLASH SPUR GEARS
ギヤ
ANTI BACKLASH SPUR GEARS

歯研平歯車
GROUND SPUR GEARS

平歯車
SPUR GEARS

内歯車
INTERNAL GEARS

歯研ラック
GROUND RACKS

ラック
RACKS

ヘリカル・スクリューギヤ
HELICAL GEARS AND SCREW GEARS

ウォーム
WORMS AND WORM WHEELS
ウォームホイール
WORMS AND WORM WHEELS

かさ歯車
BEVEL GEARS

スプロケット
SPUR METS

技術資料
REFERENCE DATA



平歯車

Spur Gears

商品記号の読み方 Reference of Catalogue Numbers

S1S25A - 0806F
= 0806
S1S25B - 0806F
+ 0806
* 0806

歯車の種類 Kind of Gear	モジュール Module	材質 Material	歯数 Number of Teeth	形状 Type	穴仕上 Bores Processed	歯幅 Face Width	穴径 Bore Diameter	追加工用商品 Gear for the item of additional machining
S : スパーギヤ Spur gears	m : 0.3, 0.5 0.75, 0.8 1.0, 1.25 1.5, 2.0 2.5, 3.0 4.0, 5.0	S : S45C Carbon Steel B : 黄銅 Brass D : ポリアセタール Poly Acetal (Machined) SU : ステンレス SUS304 Stainless Steel DM : 射出成形品 Poly Acetal (Injection molded) DB : ポリアセタール (黄銅ブッシュ入り) Acetal (with Brass Bushing)	歯数 z: 8 ~ 120	A : ハブ無し Hub less. B : 片ハブ付き With Hub on one side. BF : 片ハブ付き、 追加工用商品 Gera for the item of additional machining. L : 両軸付き With Solid shaft on both side. K : 棒状のもの Bar of gear.	【-】: キーみぞ、 ネジ穴無し 旋削仕上げ Gear without key way / without threaded hole , except types of K1 and L1. 【+】: ネジ穴付 旋削仕上げ Gear with threaded hole / with set screw. / without set screw. (Please refer the details) 【*】: ネジ穴付 旋削仕上げ Gear with two threaded holes / with two set screws. 【=】: キーみぞ付 旋削仕上げ Gear with key way / with key. 【#】: キーみぞ、 ネジ穴付 旋削仕上げ Gear with key way and threaded hole / with key and screw.	単位: ミリメートル Dimension : millimeter “広幅”と“並幅” があります。 並幅: 軽荷重用 広幅: 重荷重用 があります。 Types of Face Width: We have Wide-face width for Heavy load, and Standard-face width for Light load.	単位: ミリメートル Dimension : millimeter	"Fタイプ"、"N タイプ"と呼ん でください。追 加工して使う商 品です。 F type and N type gears are meant for additional machining. H : 歯部高周波 焼入 HRC47 ~ 53 Complete with high frequency induction hardening (HRC47 ~ 53).

平歯車 SPUR GEARS

モジュール **0.3** 圧力角 20° (並歯)
MODULE 20° PRESSURE ANGLE FULL DEPTH TOOTH

JIS B 1702-1 (ISO) 9級
System of accuracy : JIS B 1702-1(ISO) class 9

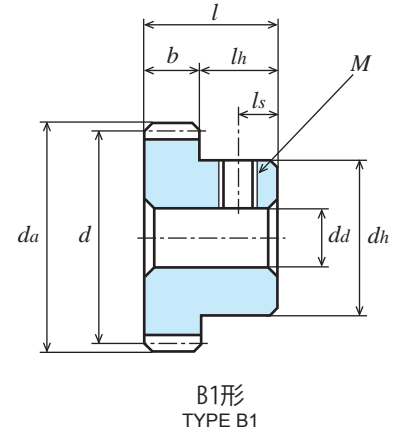
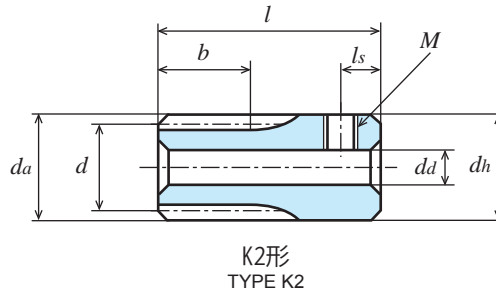

C3604B 快削黄銅棒 Material : Brass (ISO CuZn39Pb3)

単位 : mm
Dimensions : mm

商品記号 Catalogue Number	歯数 Number of Teeth z	基準円直径 Reference Diameter d	歯先円直径 Tip Diameter da	形 Type	歯幅 Face Width b	穴径 Bore Diameter da(H8)	ハブ外径 Hub Diameter dh	ハブ長さ Hub Projection lh	全長 Overall Length l	ねじ Set Screw		重量 Weight W(g)
										M	ls	
S30B 14K + 0402	14	φ 4.2	φ 4.8	K2	4	φ2	φ 5	8	12	M1.6	2.5	1.5
S30B 15K + 0402	15	φ 4.5	φ 5.1	K2	4	φ2	φ 5.5	8	12	M1.6	2.5	1.8
S30B 16K + 0402	16	φ 4.8	φ 5.4	K2	4	φ2	φ 5.5	8	12	M1.6	2.5	1.9
S30B 18K + 0402	18	φ 5.4	φ 6	K2	4	φ2	φ 6	8	12	M2	2.5	2.3
S30B 20B + 0302	20	φ 6	φ 6.6	B1	3.2	φ2	φ 5	4.8	8	M1.6	2.5	1.3
S30B 24B + 0302	24	φ 7.2	φ 7.8	B1	3.2	φ2	φ 6	4.8	8	M2	2.5	2.0
S30B 25B + 0302	25	φ 7.5	φ 8.1	B1	3.2	φ2	φ 6	4.8	8	M2	2.5	2.1
S30B 28B + 0302	28	φ 8.4	φ 9	B1	3.2	φ2	φ 7	4.8	8	M2	2.5	2.8
S30B 30B + 0302	30	φ 9	φ 9.6	B1	3.2	φ2	φ 8	4.8	8	M2	2.5	3.5
S30B 32B + 0202	32	φ 9.6	φ 10.2	B1	2	φ2	φ 8	6	8	M2	3	3.5
S30B 35B + 0202	35	φ 10.5	φ 11.1	B1	2	φ2	φ 8	6	8	M2	3	3.8
S30B 36B + 0203	36	φ 10.8	φ 11.4	B1	2	φ3	φ 9	6	8	M3	3	4.2
S30B 40B + 0203	40	φ 12	φ 12.6	B1	2	φ3	φ 10	6	8	M3	3	5.3
S30B 45B + 0203	45	φ 13.5	φ 14.1	B1	2	φ3	φ 10	6	8	M3	3	5.8
S30B 48B + 0203	48	φ 14.4	φ 15	B1	2	φ3	φ 10	6	8	M3	3	6.1

セットスクリューは付いておりません。

[+]: Gear with threaded hole / without set screw.

許容伝達動力表 曲げ強さ (W)

Allowable transfer capability table (W) Bending Strength

商品記号 Catalogue Numbers	回転速度 (min ⁻¹) revolution/min						
	10	100	200	400	800	1,200	1,500
S30B 14K + 0402	0.03	0.32	0.64	1.27	2.55	3.82	4.78
S30B 15K + 0402	0.04	0.36	0.71	1.43	2.86	4.29	5.36
S30B 16K + 0402	0.04	0.40	0.79	1.59	3.17	4.76	5.95
S30B 18K + 0402	0.05	0.48	0.95	1.91	3.81	5.72	7.15
S30B 20B + 0302	0.04	0.45	0.90	1.79	3.58	5.37	6.71
S30B 24B + 0302	0.06	0.58	1.17	2.33	4.67	7.00	8.75
S30B 25B + 0302	0.06	0.62	1.24	2.47	4.95	7.42	9.27
S30B 28B + 0302	0.07	0.72	1.45	2.89	5.79	8.68	10.86
S30B 30B + 0302	0.08	0.79	1.59	3.18	6.36	9.54	11.92
S30B 32B + 0202	0.05	0.54	1.08	2.17	4.33	6.50	8.12
S30B 35B + 0202	0.06	0.61	1.22	2.44	4.88	7.32	9.15
S30B 36B + 0203	0.06	0.63	1.27	2.53	5.06	7.59	9.49
S30B 40B + 0203	0.07	0.72	1.45	2.90	5.80	8.70	10.87
S30B 45B + 0203	0.08	0.84	1.68	3.36	6.72	10.09	12.49
S30B 48B + 0203	0.09	0.91	1.82	3.64	7.29	10.93	13.40

The above numerical values are equivalent to JGMA formulas as reference only.

動力の換算式は P26 をご参照ください。

Please refer to the conversion formulas of power on page P26.

RoHS 対応

2006年11月生産開始分より欧州 RoHS 指令に対応できる商品を提供しています。

We supplied the KG-products with RoHS compliance of EU to all our valued customers since November 2006

JIS B 1702-1 (ISO) 9 級
System of accuracy : JIS B 1702-1(ISO) class 9



御注文には必ず“フルネームで商品記号”を明記してください。
Please refer to the catalogue reference while ordering.

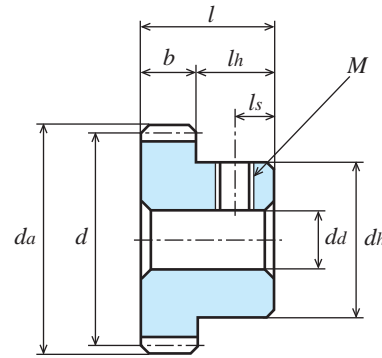

B1形
TYPE B1

C3604B 快削黄銅棒

Material : Brass (ISO CuZn39Pb3)

単位 : mm
Dimensions : mm

商品記号 Catalogue Number	歯数 Number of Teeth z	基準円直径 Reference Diameter d	歯先円直径 Tip Diameter da	形 Type	歯幅 Face Width b	穴径 Bore Diameter da(H8)	ハブ外径 Hub Diameter dh	ハブ長さ Hub Projection lh	全長 Overall Length l	ねじ Set Screw		重量 Weight W(g)
										M	ls	
S30B 50B + 0203	50	φ15	φ15.6	B1	2	φ3	φ10	6	8	M3	3	6.4
S30B 56B + 0203	56	φ16.8	φ17.4	B1	2	φ3	φ10	6	8	M3	3	7.1
S30B 60B + 0203	60	φ18	φ18.6	B1	2	φ3	φ10	6	8	M3	3	7.7
S30B 64B + 0203	64	φ19.2	φ19.8	B1	2	φ3	φ10	6	8	M3	3	8.3
S30B 66B + 0203	66	φ19.8	φ20.4	B1	2	φ3	φ10	6	8	M3	3	8.6
S30B 70B + 0203	70	φ21	φ21.6	B1	2	φ3	φ10	6	8	M3	3	9.3
S30B 72B + 0203	72	φ21.6	φ22.2	B1	2	φ3	φ10	6	8	M3	3	9.6
S30B 75B + 0203	75	φ22.5	φ23.1	B1	2	φ3	φ10	6	8	M3	3	10.1
S30B 80B + 0203	80	φ24	φ24.6	B1	2	φ3	φ10	6	8	M3	3	11.1
S30B 90B + 0203	90	φ27	φ27.6	B1	2	φ3	φ10	6	8	M3	3	13.1
S30B 96B + 0203	96	φ28.8	φ29.4	B1	2	φ3	φ10	6	8	M3	3	14.4
S30B 100B + 0203	100	φ30	φ30.6	B1	2	φ3	φ10	6	8	M3	3	15.4
S30B 108B + 0203	108	φ32.4	φ33	B1	2	φ3	φ10	6	8	M3	3	17.4
S30B 120B + 0203	120	φ36	φ36.6	B1	2	φ3	φ10	6	8	M3	3	20.7

セットスクリューは付いておりません。

[+]: Gear with threaded hole / without set screw.

許容伝達動力表 曲げ強さ (W)

Allowable transfer capability table (W) Bending Strength

商品記号 Catalogue Numbers	回転速度 (min ⁻¹) revolution/min						
	10	100	200	400	800	1,200	1,500
S30B 50B + 0203	0.10	0.96	1.92	3.83	7.66	11.49	13.99
S30B 56B + 0203	0.11	1.10	2.20	4.40	8.80	13.09	15.74
S30B 60B + 0203	0.12	1.20	2.39	4.78	9.56	14.07	16.88
S30B 64B + 0203	0.13	1.29	2.58	5.16	10.33	15.02	17.99
S30B 66B + 0203	0.13	1.34	2.68	5.36	10.71	15.50	18.54
S30B 70B + 0203	0.14	1.43	2.87	5.74	11.48	16.43	19.61
S30B 72B + 0203	0.15	1.48	2.97	5.93	11.87	16.89	20.14
S30B 75B + 0203	0.16	1.56	3.11	6.22	12.44	17.58	20.92
S30B 80B + 0203	0.17	1.68	3.35	6.71	13.40	18.69	22.20
S30B 90B + 0203	0.19	1.92	3.83	7.67	15.04	20.83	24.62
S30B 96B + 0203	0.21	2.06	4.13	8.25	16.01	22.07	26.02
S30B 100B + 0203	0.22	2.16	4.32	8.64	16.64	22.89	26.93
S30B 108B + 0203	0.24	2.36	4.71	9.42	17.88	24.46	28.68
S30B 112B + 0203	0.25	2.45	4.91	9.81	18.49	25.23	29.54
S30B 120B + 0203	0.26	2.65	5.30	10.60	19.69	26.73	31.19

The above numerical values are equivalent to JGMA formulas as reference only.

動力の換算式は P26 をご参照ください。

Please refer to the conversion formulas of power on page P26.

RoHS 対応

2006年11月生産開始分より欧州 RoHS 指令に対応できる商品を提供しています。

We supplied the KG-products with RoHS compliance of EU to all our valued customers since November 2006

Memo

目次
CONTENTS

インフォメーション
INFORMATION

ギヤボックス
GEAR BOXES

ノーバックス
ANTI BACKLASH SPUR GEAR
ギヤ

歯研平歯車
GROUND SPUR GEARS

平歯車
SPUR GEARS

内歯車
INTERNAL GEARS

歯研ラック
GROUND RACKS

ラック
RACKS

ヘリカル・スクリューギヤ
HELICAL GEARS AND SCREW GEARS

ウォーム
WORMS AND WORM WHEELS
ウォームホイール

かさ歯車
BEVEL GEARS

スプロケット
SPURKETS

技術資料
REFERENCE DATA

平歯車 SPUR GEARS

モジュール **0.5** 圧力角 20° (並歯)
MODULE 20° PRESSURE ANGLE FULL DEPTH TOOTH

JIS B 1702-1 (ISO) 11 級
System of accuracy : JIS B 1702-1(ISO) class 11



御注文には必ず“フルネームで商品記号”を明記してください。
Please refer to the catalogue reference while ordering.

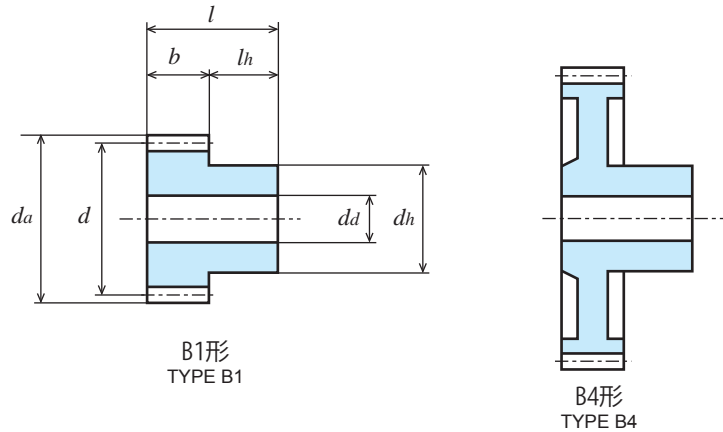

ポリアセタール (黒色)
Material : Poly Acetal (Black)

射出成形品 穴径 (da) の追加加工はなるべくしないで下さい。気泡 (す) がでることがあります。
Injection Molded gears Additional machining to bore (da) is not advisable because 'voids' may be occur.

単位 : mm
Dimensions : mm

商品記号 Catalogue Number	歯数 Number of Teeth z	基準円直径 Reference Diameter d	歯先円直径 Tip Diameter da	形 Type	歯幅 Face Width b	穴径 Bore Diameter da	ハブ外径 Hub Diameter dh	ハブ長さ Hub Projection lh	全長 Overall Length l	重量 Weight W(g)
S50DM 20B - 0403	20	φ10	φ11	B1	4	φ3	φ8	4	8	0.9
S50DM 24B - 0303	24	φ12	φ13	B1	3	φ3	φ10	5	8	1.0
S50DM 30B - 0303	30	φ15	φ16	B1	3	φ3	φ10	5	8	1.2
S50DM 40B - 0303	40	φ20	φ21	B4	3	φ3	φ10	5	8	1.5
S50DM 50B - 0303	50	φ25	φ26	B4	3	φ3	φ10	5	8	2.0
S50DM 60B - 0303	60	φ30	φ31	B4	3	φ3	φ10	5	8	2.7
S50DM 80B - 0303	80	φ40	φ41	B4	3	φ3	φ10	5	8	4.4
S50DM 100B - 0303	100	φ50	φ51	B4	3	φ3	φ10	5	8	6.6

許容伝達動力表 曲げ強さ (W)

Allowable transfer capability table (W) Bending Strength

商品記号 Catalogue Numbers	回転速度 (min ⁻¹) revolution/min						
	10	100	200	400	800	1,200	1,500
S50DM 20B - 0403	0.18	1.84	3.67	7.34	14.67	21.97	27.44
S50DM 24B - 0303	0.17	1.65	3.31	6.61	13.19	19.76	24.67
S50DM 30B - 0303	0.21	2.07	4.13	8.25	16.48	24.67	30.80
S50DM 40B - 0303	0.28	2.75	5.51	11.00	21.94	32.84	40.97
S50DM 50B - 0303	0.34	3.44	6.88	13.74	27.40	40.97	51.10
S50DM 60B - 0303	0.41	4.13	8.25	16.48	32.84	49.08	61.18
S50DM 80B - 0303	0.55	5.51	11.00	21.94	43.68	65.19	80.75
S50DM 100B - 0303	0.69	6.88	13.74	27.40	54.47	80.75	99.78

The above numerical values are Lewis formulas as reference only.

動力の換算式は P26 をご参照ください。

Please refer to the conversion formulas of power on page P26.

平歯車

SPUR GEARS

モジュール **0.5** 圧力角 20° (並歯)
 MODULE 20° PRESSURE ANGLE FULL DEPTH TOOTH

JIS B 1702-1 (ISO) 9~10 級
 System of accuracy : JIS B 1702-1(ISO) class 9-10

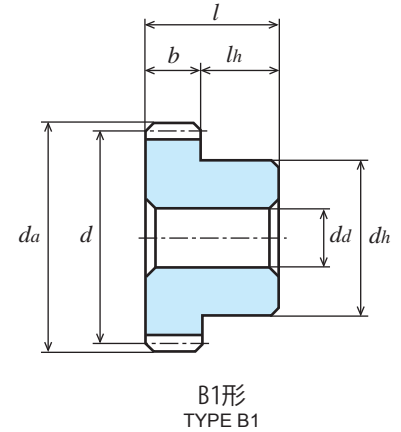
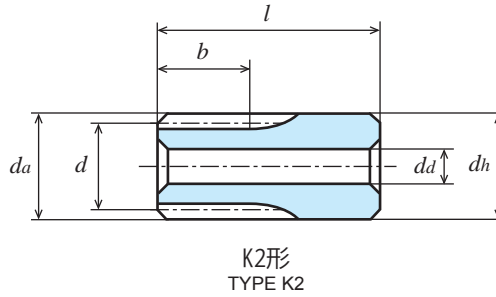

ポリアセタール (白色)
 Material : Poly Acetal (White)

機械加工品
 Machined Gears

単位 : mm
 Dimensions : mm

商品記号 Catalogue Number	歯数 Number of Teeth z	基準円直径 Reference Diameter d	歯先円直径 Tip Diameter da	形 Type	歯幅 Face Width b	穴径 Bore Diameter da	ハブ外径 Hub Diameter dh	ハブ長さ Hub Projection lh	全長 Overall Length l	重量 Weight $W(g)$
S50D 14K - 0803	14	$\phi 7$	$\phi 8$	K2	8	$\phi 3$	$\phi 9$	10	18	1.15
S50D 15K - 0803	15	$\phi 7.5$	$\phi 8.5$	K2	8	$\phi 3$	$\phi 9$	10	18	1.22
S50D 16K - 0803	16	$\phi 8$	$\phi 9$	K2	8	$\phi 3$	$\phi 9$	10	18	1.29
S50D 18K - 0803	18	$\phi 9$	$\phi 10$	K2	8	$\phi 3$	$\phi 10$	10	18	1.65
S50D 20B - 0303	20	$\phi 10$	$\phi 11$	B1	3	$\phi 3$	$\phi 8$	5	8	0.61
S50D 24B - 0303	24	$\phi 12$	$\phi 13$	B1	3	$\phi 3$	$\phi 8$	5	8	0.75
S50D 25B - 0303	25	$\phi 12.5$	$\phi 13.5$	B1	3	$\phi 3$	$\phi 8$	5	8	0.79
S50D 28B - 0303	28	$\phi 14$	$\phi 15$	B1	3	$\phi 3$	$\phi 8$	5	8	0.93
S50D 30B - 0303	30	$\phi 15$	$\phi 16$	B1	3	$\phi 3$	$\phi 8$	5	8	0.97
S50D 32B - 0303	32	$\phi 16$	$\phi 17$	B1	3	$\phi 3$	$\phi 8$	5	8	1.13
S50D 36B - 0303	36	$\phi 18$	$\phi 19$	B1	3	$\phi 3$	$\phi 8$	5	8	1.35
S50D 40B - 0303	40	$\phi 20$	$\phi 21$	B1	3	$\phi 3$	$\phi 10$	5	8	1.81

波形スプリングピン付き、呼び径は $\phi 1$ です。(ステンレス)
 Gear with Corrugated spring (SUS) as dimension of $\phi 1.0$

目次
CONTENTS

インフォメーション
INFORMATION

ギヤボックス
GEAR BOXES

ノーバックラッシュギヤ
ANTI BACKLASH SPUR GEARS

歯研平歯車
GROUND SPUR GEARS

平歯車
SPUR GEARS

内歯車
INTERNAL GEARS

歯研ラック
GROUND RACKS

ラック
RACKS

へリカルスクリューギヤ
HELICAL GEARS AND SCREW GEARS

ウォーム
ウォームホイール
WORMS AND WORM WHEELS

かさ歯車
BEVEL GEARS

スプロケット
SPURKETS

技術資料
REFERENCE DATA

平歯車 SPUR GEARS

モジュール **0.5** 圧力角 20° (並歯)
MODULE 20° PRESSURE ANGLE FULL DEPTH TOOTH

JIS B 1702-1 (ISO) 9~10 級
System of accuracy : JIS B 1702-1(ISO) class 9-10



御注文には必ず“フルネームで商品記号”を明記してください。
Please refer to the catalogue reference while ordering.

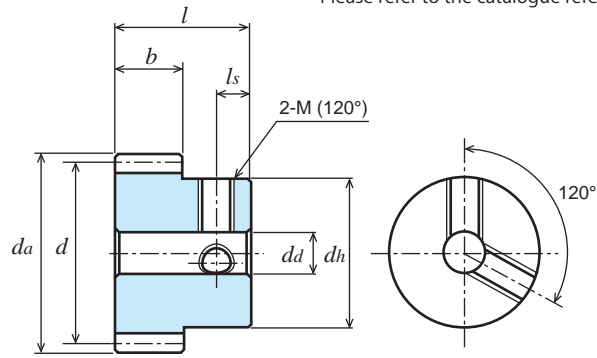

B1形
TYPE B1

ポリアセタール (白色)
Material : Poly Acetal (White)

機械加工品
Machined Gears

単位 : mm
Dimensions : mm

商品記号 Catalogue Number	歯数 Number of Teeth z	基準円直径 Reference Diameter d	歯先円直径 Tip Diameter da	形 Type	歯幅 Face Width b	穴径 Bore Diameter da	ハブ外径 Hub Diameter dh	ハブ長さ Hub Projection lh	全長 Overall Length l	ねじ Set Screw		重量 Weight W(g)
										2-M(120°)	ls	
S50D 14K * 0803	14	φ 7	φ 8	K2	8	φ3	φ 9	10	18	2-M3	3	1.10
S50D 15K * 0803	15	φ 7.5	φ 8.5	K2	8	φ3	φ 9	10	18	2-M3	3	1.17
S50D 16K * 0803	16	φ 8	φ 9	K2	8	φ3	φ 9	10	18	2-M3	3	1.24
S50D 18K * 0803	18	φ 9	φ10	K2	8	φ3	φ10	10	18	2-M3	3	1.59
S50D 20B * 0303	20	φ10	φ11	B1	3	φ3	φ 8	5	8	2-M3	3	0.57
S50D 24B * 0303	24	φ12	φ13	B1	3	φ3	φ10	5	8	2-M3	3	0.90
S50D 25B * 0303	25	φ12.5	φ13.5	B1	3	φ3	φ10	5	8	2-M3	3	0.94
S50D 28B * 0303	28	φ14	φ15	B1	3	φ3	φ12	5	8	2-M3	3	1.30
S50D 30B * 0303	30	φ15	φ16	B1	3	φ3	φ12	5	8	2-M3	3	1.39
S50D 32B * 0303	32	φ16	φ17	B1	3	φ3	φ14	5	8	2-M3	3	1.77
S50D 36B * 0303	36	φ18	φ19	B1	3	φ3	φ15	5	8	2-M3	3	2.15
S50D 40B * 0303	40	φ20	φ21	B1	3	φ3	φ15	5	8	2-M3	3	2.40

【*】(アスタ)にはセットスクリーが2個付いております。
[*] : Gear with two threaded holes / with two set screws.

許容伝達動力表 曲げ強さ (W)

Allowable transfer capability table (W) Bending Strength

商品記号 Catalogue Numbers	回転速度 (min ⁻¹) revolution/min						
	10	100	200	400	800	1,200	1,500
S50D 14K * 0803	0.22	2.24	4.48	8.95	17.89	26.82	33.50
S50D 15K * 0803	0.24	2.40	4.80	9.59	19.17	28.73	35.88
S50D 16K * 0803	0.26	2.56	5.12	10.23	20.44	30.64	38.27
S50D 18K * 0803	0.29	2.88	5.76	11.51	22.99	34.45	43.03
S50D 20B * 0303	0.12	1.20	2.40	4.79	9.58	14.35	17.92
S50D 24B * 0303	0.17	1.74	3.48	6.96	13.90	20.82	25.99
S50D 25B * 0303	0.18	1.81	3.63	7.25	14.47	21.68	27.07
S50D 28B * 0303	0.20	2.03	4.06	8.12	16.21	24.27	30.30
S50D 30B * 0303	0.22	2.18	4.35	8.70	17.36	25.99	32.45
S50D 32B * 0303	0.23	2.32	4.64	9.27	18.51	27.71	34.59
S50D 36B * 0303	0.26	2.61	5.22	10.43	20.82	31.16	38.88
S50D 40B * 0303	0.29	2.90	5.80	11.59	23.12	34.59	43.16

The above numerical values are Lewis formulas as reference only.
動力の換算式は P26 をご参照ください。
Please refer to the conversion formulas of power on page P26.

目次
CONTENTS

インフォメーション
INFORMATION

ギヤボックス
GEAR BOXES

ノーバッキングギヤ
ANTI BACKLASH SPUR GEARS

歯研削歯車
GROUND SPUR GEARS

平歯車
SPUR GEARS

内歯車
INTERNAL GEARS

歯研削ラック
GROUND RACKS

ラック
RACKS

ハニカム・スクリューギヤ
HELICAL GEARS AND SCREW GEARS

ウォーム・ウォームホイール
WORMS AND WORM WHEELS

かさ歯車
BEVEL GEARS

スプロケット
SPROCKETS

技術仕様
REFERENCE DATA

平歯車

SPUR GEARS

モジュール **0.5** 圧力角 20° (並歯)
 MODULE 20° PRESSURE ANGLE FULL DEPTH TOOTH

JIS B 1702-1 (ISO) 9~10 級
 System of accuracy : JIS B 1702-1(ISO) class 9-10

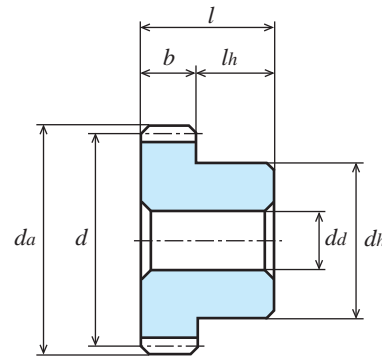

B1形
TYPE B1

ポリアセタール (白色)
Material : Poly Acetal (White)

機械加工品
Machined Gears

単位 : mm
Dimensions : mm

商品記号 Catalogue Number	歯数 Number of Teeth z	基準円直径 Reference Diameter d	歯先円直径 Tip Diameter d_a	形 Type	歯幅 Face Width b	穴径 Bore Diameter d_d	ハブ外径 Hub Diameter d_h	ハブ長さ Hub Projection l_h	全長 Overall Length l	重量 Weight $W(g)$
S50D 45B - 0303	45	φ22.5	φ23.5	B1	3	φ3	φ10	5	8	2.17
S50D 50B - 0303	50	φ25	φ26	B1	3	φ3	φ10	5	8	2.56
S50D 56B - 0303	56	φ28	φ29	B1	3	φ3	φ10	5	8	3.09
S50D 60B - 0303	60	φ30	φ31	B1	3	φ3	φ10	5	8	3.40
S50D 64B - 0303	64	φ32	φ33	B1	3	φ3	φ10	5	8	3.90
S50D 70B - 0304	70	φ35	φ36	B1	3	φ4	φ12	5	8	4.70
S50D 72B - 0304	72	φ36	φ37	B1	3	φ4	φ12	5	8	4.99
S50D 80B - 0304	80	φ40	φ41	B1	3	φ4	φ12	5	8	6.01
S50D 90B - 0305	90	φ45	φ46	B1	3	φ5	φ14	5	8	7.64
S50D 100B - 0305	100	φ50	φ51	B1	3	φ5	φ14	5	8	9.22
S50D 120B - 0305	120	φ60	φ61	B1	3	φ5	φ14	5	8	12.90

波形スプリングピン付き、呼び径はφ1です。(ステンレス)
 Gear with Corrugated spring (SUS) as dimension of φ1.0

目次
CONTENTS

インフォメーション
INFORMATION

ギヤボックス
GEAR BOXES

ノーバックス
ANTI BACKLASH SPUR GEARS

歯研平歯車
GROUND SPUR GEARS

平歯車
SPUR GEARS

内歯車
INTERNAL GEARS

歯研ラック
GROUND RACKS

ラック
RACKS

ヘリカル
HELICAL GEARS AND SCREW GEARS

ウォーム
WORMS AND WORM WHEELS

かさ歯車
BEVEL GEARS

スプロケット
SPURKETS

技術資料
REFERENCE DATA

平歯車

SPUR GEARS

モジュール **0.5** 圧力角 20° (並歯)
 MODULE 20° PRESSURE ANGLE FULL DEPTH TOOTH

JIS B 1702-1 (ISO) 9~10 級
 System of accuracy : JIS B 1702-1(ISO) class 9-10



御注文には必ず“フルネームで商品記号”を明記してください。
 Please refer to the catalogue reference while ordering.

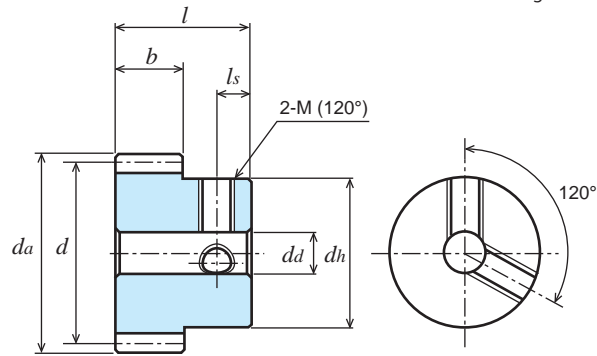

B1形
TYPE B1

ポリアセタール (白色)
 Material : Poly Acetal (White)

機械加工品
 Machined Gears

単位 : mm
 Dimensions : mm

商品記号 Catalogue Number	歯数 Number of Teeth z	基準円直径 Reference Diameter d	歯先円直径 Tip Diameter da	形 Type	歯幅 Face Width b	穴径 Bore Diameter da	ハブ外径 Hub Diameter dh	ハブ長さ Hub Projection lh	全長 Overall Length l	ねじ Set Screw		重量 Weight W(g)
										2-M(120°)	ls	
S50D 45B * 0303	45	φ22.5	φ23.5	B1	3	φ3	φ15	5	8	2-M3	3	2.75
S50D 50B * 0303	50	φ25	φ26	B1	3	φ3	φ15	5	8	2-M3	3	3.15
S50D 56B * 0303	56	φ28	φ29	B1	3	φ3	φ15	5	8	2-M3	3	3.67
S50D 60B * 0303	60	φ30	φ31	B1	3	φ3	φ15	5	8	2-M3	3	4.06
S50D 64B * 0303	64	φ32	φ33	B1	3	φ3	φ15	5	8	2-M3	3	4.47
S50D 70B * 0304	70	φ35	φ36	B1	3	φ4	φ16	5	8	2-M3	3	5.25
S50D 72B * 0304	72	φ36	φ37	B1	3	φ4	φ16	5	8	2-M3	3	5.48
S50D 80B * 0304	80	φ40	φ41	B1	3	φ4	φ16	5	8	2-M3	3	6.49
S50D 90B * 0305	90	φ45	φ46	B1	3	φ5	φ18	5	8	2-M3	3	8.20
S50D 100B * 0305	100	φ50	φ51	B1	3	φ5	φ18	5	8	2-M3	3	9.77
S50D 120B * 0305	120	φ60	φ61	B1	3	φ5	φ18	5	8	2-M3	3	13.43

【*】(アスタ)にはセットスクリーが2個付いております。

[*] : Gear with two threaded holes / with two set screws.

許容伝達動力表 曲げ強さ (W)

Allowable transfer capability table (W) Bending Strength

商品記号 Catalogue Numbers	回転速度 (min ⁻¹) revolution/min						
	10	100	200	400	800	1,200	1,500
S50D 45B * 0303	0.33	3.26	6.52	13.03	25.99	38.88	48.50
S50D 50B * 0303	0.36	3.63	7.25	14.47	28.86	43.16	53.83
S50D 56B * 0303	0.41	4.06	8.12	16.21	32.30	48.29	60.21
S50D 60B * 0303	0.44	4.35	8.70	17.36	34.59	51.70	64.45
S50D 64B * 0303	0.46	4.64	9.27	18.51	36.88	55.11	68.68
S50D 70B * 0304	0.51	5.08	10.14	20.24	40.31	60.21	74.86
S50D 72B * 0304	0.52	5.22	10.43	20.82	41.45	61.91	76.91
S50D 80B * 0304	0.58	5.80	11.59	23.12	46.01	68.68	85.07
S50D 90B * 0305	0.65	6.52	13.03	25.99	51.70	76.91	95.15
S50D 100B * 0305	0.73	7.25	14.47	28.86	57.38	85.07	105.11
S50D 120B * 0305	0.87	8.70	17.36	34.59	68.68	101.14	124.67

The above numerical values are Lewis formulas as reference only.

動力の換算式は P26 をご参照ください。

Please refer to the conversion formulas of power on page P26.

目次
CONTENTS

インフォメーション
INFORMATION

ギヤボックス
GEAR BOXES

ノーバッキングギヤ
ANTI BACKLASH SPUR GEARS

歯研平歯車
GROUND SPUR GEARS

平歯車
SPUR GEARS

内歯車
INTERNAL GEARS

歯研ラック
GROUND RACKS

ラック
RACKS

ハニカム・スクリューギヤ
HELICAL GEARS AND SCREW GEARS

ウォーム・ウォームホイール
WORMS AND WORM WHEELS

かさ歯車
BEVEL GEARS

スプロケット
SPROCKETS

技術仕様
REFERENCE DATA

平歯車 SPUR GEARS

モジュール **0.5** 圧力角 20° (並歯)
MODULE 20° PRESSURE ANGLE FULL DEPTH TOOTH

JIS B 1702-1 (ISO) 9級
System of accuracy : JIS B 1702-1(ISO) class 9



New **ねじを2箇所 (120°配) にしました。**
New item with two threaded holes (120°)

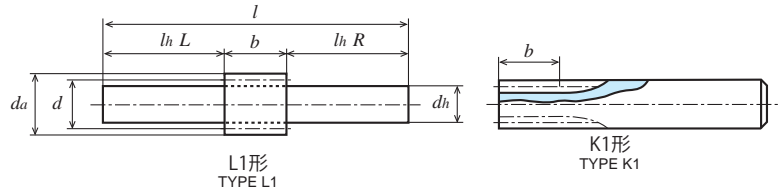
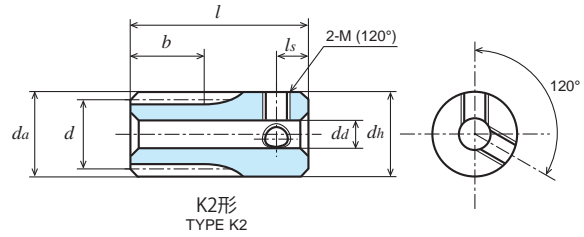

SUS304 ステンレス鋼棒 (JIS G 4303) Material : Stainless Steel SUS304 (JIS G 4303)

単位 : mm
Dimensions : mm

商品記号 Catalogue Number	歯数 Number of Teeth z	基準円直径 Reference Diameter d	歯先円直径 Tip Diameter da	形 Type	歯幅 Face Width b	穴径 Bore Diameter da(H8)	ハブ外径 Hub Diameter dh	ハブ長さ Hub Projection lh	全長 Overall Length l	ねじ Set Screw		重量 Weight W(g)
										2-M(120°)	ls	
S50SU 10K - 1006	10	φ 5	φ 6	K1	10	-	φ 6	45	55	-	-	11.7
S50SU 12K - 1007	12	φ 6	φ 7	K1	10	-	φ 7	45	55	-	-	16.0
S50SU 14K - 1008	14	φ 7	φ 8	K1	10	-	φ 8	45	55	-	-	21.0
S50SU 15K - 1008	15	φ 7.5	φ 8.5	K1	10	-	φ 8.5	45	55	-	-	23.8
S50SU 16K * 0804	16	φ 8	φ 9	K2	8	φ4	φ 9	10	18	2-M3	3	6.2
S50SU 16L - 0805	16	φ 8	φ 9	L1	8	-	φ 5 (h9)	L22 R50	80	-	-	14.4
S50SU 18K * 0804	18	φ 9	φ 10	K2	8	φ4	φ 10	10	18	2-M3	3	8.2
S50SU 18L - 0806	18	φ 9	φ 10	L1	8	-	φ 6 (h9)	L22 R50	80	-	-	20.2
S50SU 20K * 0804	20	φ 10	φ 11	K2	8	φ4	φ 11	10	18	2-M3	3	10.4
S50SU 20L - 0806	20	φ 10	φ 11	L1	8	-	φ 6 (h9)	L22 R50	80	-	-	21.1
S50SU 24K * 0805	24	φ 12	φ 13	K2	8	φ5	φ 13	10	18	2-M3	3	14.5
S50SU 25K * 0805	25	φ 12.5	φ 13.5	K2	8	φ5	φ 13.5	10	18	2-M3	3	15.9
S50SU 28K * 0805	28	φ 14	φ 15	K2	8	φ5	φ 15	10	18	2-M3	3	20.5
S50SU 30K * 0806	30	φ 15	φ 16	K2	8	φ6	φ 16	10	18	2-M3	3	22.7

SUS304の商品にはセットスクリューは付いておりません。[*]: Gear with two threaded holes / without set screw.

許容伝達動力表 曲げ強さ (W)

Allowable transfer capability table (W) Bending Strength

商品記号 Catalogue Numbers	回転速度 (min ⁻¹) revolution/min						
	10	100	200	400	800	1,200	1,500
S50SU 10K - 1006	0.30	3.03	6.06	12.12	24.24	36.37	45.46
S50SU 12K - 1007	0.42	4.24	8.49	16.98	33.96	50.93	63.67
S50SU 14K - 1008	0.55	5.53	11.07	22.13	44.26	66.39	82.99
S50SU 15K - 1008	0.62	6.20	12.40	24.80	49.60	74.41	93.01
S50SU 16K * 0804	0.55	5.50	11.01	22.02	44.04	66.06	82.57
S50SU 16L - 0805	0.55	5.50	11.01	22.02	44.04	66.06	82.57
S50SU 18K * 0804	0.66	6.62	13.24	26.47	52.94	79.41	99.26
S50SU 18L - 0806	0.66	6.62	13.24	26.47	52.94	79.41	99.26
S50SU 20K * 0804	0.78	7.77	15.54	31.08	62.16	93.24	116.55
S50SU 20L - 0806	0.78	7.77	15.54	31.08	62.16	93.24	116.55
S50SU 24K * 0805	1.01	10.13	20.26	40.52	81.04	121.55	151.94
S50SU 25K * 0805	1.07	10.73	21.46	42.93	85.86	128.79	160.96
S50SU 28K * 0805	1.26	12.56	25.13	50.26	100.52	150.77	185.69
S50SU 30K * 0806	1.38	13.80	27.59	55.18	110.37	165.55	201.56

The above numerical values are equivalent to JGMA formulas as reference only.

動力の換算式は P26 をご参照ください。

Please refer to the conversion formulas of power on page P26.

平歯車

SPUR GEARS

モジュール **0.5** 圧力角 20° (並歯)
 MODULE 20° PRESSURE ANGLE FULL DEPTH TOOTH

JIS B 1702-1 (ISO) 9級
 System of accuracy : JIS B 1702-1(ISO) class 9



御注文には必ず“フルネームで商品記号”を明記してください。
 Please refer to the catalogue reference while ordering.

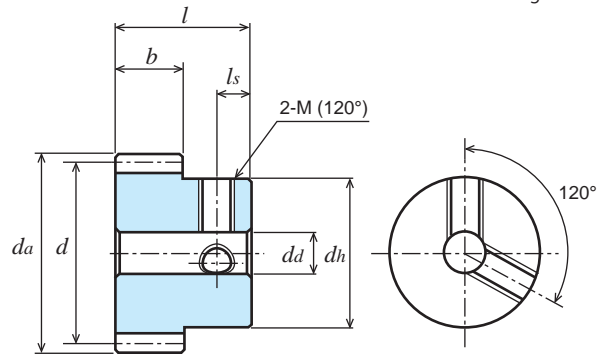

B1形
TYPE B1

SUS304 ステンレス鋼棒 (JIS G 4303)

Material : Stainless Steel SUS304 (JIS G 4303)

単位 : mm
Dimensions : mm

商品記号 Catalogue Number	歯数 Number of Teeth z	基準円直径 Reference Diameter d	歯先円直径 Tip Diameter da	形 Type	歯幅 Face Width b	穴径 Bore Diameter da(H8)	ハブ外径 Hub Diameter dh	ハブ長さ Hub Projection lh	全長 Overall Length l	ねじ Set Screw		重量 Weight W(g)
										2-M(120°)	ls	
S50SU 32B * 0506	32	φ16	φ17	B1	5	φ 6	φ12	8	13	2-M3	4	12.0
S50SU 36B * 0506	36	φ18	φ19	B1	5	φ 6	φ12	8	13	2-M3	4	14.1
S50SU 40B * 0506	40	φ20	φ21	B1	5	φ 6	φ15	8	13	2-M4	4	20.0
S50SU 45B * 0506	45	φ22.5	φ23.5	B1	5	φ 6	φ15	8	13	2-M4	4	23.3
S50SU 48B * 0506	48	φ24	φ25	B1	5	φ 6	φ15	8	13	2-M4	4	25.5
S50SU 50B * 0506	50	φ25	φ26	B1	5	φ 6	φ15	8	13	2-M4	4	27.0
S50SU 54B * 0506	54	φ27	φ28	B1	5	φ 6	φ15	8	13	2-M4	4	30.3
S50SU 56B * 0506	56	φ28	φ29	B1	5	φ 6	φ15	8	13	2-M4	4	32.0
S50SU 60B * 0508	60	φ30	φ31	B1	5	φ 8	φ18	8	13	2-M4	4	38.2
S50SU 64B * 0508	64	φ32	φ33	B1	5	φ 8	φ18	8	13	2-M4	4	42.0
S50SU 70B * 0508	70	φ35	φ36	B1	5	φ 8	φ18	8	13	2-M4	4	48.3
S50SU 72B * 0508	72	φ36	φ37	B1	5	φ 8	φ18	8	13	2-M4	4	50.5
S50SU 75B * 0508	75	φ37.5	φ38.5	B1	5	φ 8	φ18	8	13	2-M4	4	53.9
S50SU 80B * 0510	80	φ40	φ41	B1	5	φ10	φ22	8	13	2-M5	4	64.3
S50SU 90B * 0510	90	φ45	φ46	B1	5	φ10	φ22	8	13	2-M5	4	77.5
S50SU 100B * 0510	100	φ50	φ51	B1	5	φ10	φ25	8	13	2-M5	4	98.9
S50SU 120B * 0510	120	φ60	φ61	B1	5	φ10	φ25	8	13	2-M5	4	133.2

SUS304 の商品にはセットスクリューは付いておりません。[*]: Gear with two threaded holes / without set screw.

許容伝達動力表 曲げ強さ (W)

Allowable transfer capability table (W) Bending Strength

商品記号 Catalogue Numbers	回転速度 (min ⁻¹) revolution/min						
	10	100	200	400	800	1,200	1,500
S50SU 32B * 0506	0.94	9.40	18.81	37.61	75.22	112.74	135.81
S50SU 36B * 0506	1.10	10.98	21.96	43.93	87.85	129.24	155.10
S50SU 40B * 0506	1.26	12.58	25.16	50.32	100.65	145.37	173.83
S50SU 45B * 0506	1.46	14.59	29.18	58.37	116.74	164.87	196.29
S50SU 48B * 0506	1.58	15.81	31.63	63.25	126.40	176.32	209.39
S50SU 50B * 0506	1.66	16.63	33.26	66.52	132.10	183.82	217.95
S50SU 54B * 0506	1.83	18.27	36.54	73.08	143.35	198.52	234.63
S50SU 56B * 0506	1.91	19.10	38.19	76.38	148.90	205.71	242.76
S50SU 60B * 0508	2.07	20.75	41.50	83.00	159.84	219.81	258.63
S50SU 64B * 0508	2.24	22.41	44.82	89.64	170.57	233.52	273.96
S50SU 70B * 0508	2.49	24.91	49.82	99.65	186.27	253.37	296.02
S50SU 72B * 0508	2.57	25.75	51.50	102.99	191.40	259.80	303.14
S50SU 75B * 0508	2.70	27.01	54.01	108.02	199.00	269.28	313.58
S50SU 80B * 0510	2.91	29.11	58.21	116.42	211.43	284.66	334.02
S50SU 90B * 0510	3.33	33.28	66.56	133.13	235.05	313.46	376.29
S50SU 100B * 0510	3.75	37.50	75.01	148.96	257.73	344.32	417.84
S50SU 120B * 0510	4.60	45.99	91.98	177.13	299.84	412.29	497.84

The above numerical values are equivalent to JGMA formulas as reference only.

動力の換算式は P26 をご参照ください。

Please refer to the conversion formulas of power on page P26.

平歯車 SPUR GEARS

モジュール **0.5** 圧力角 20° (並歯)
MODULE 20° PRESSURE ANGLE FULL DEPTH TOOTH

JIS B 1702-1 (ISO) 9~10 級
System of accuracy : JIS B 1702-1(ISO) class 9-10

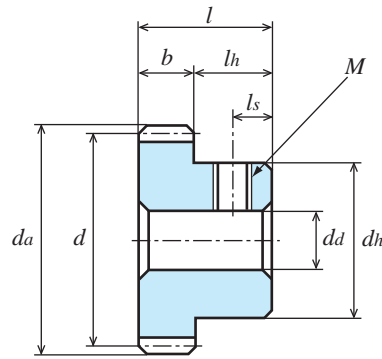

B1形
TYPE B1

C3604B 快削黄銅棒 Material : Brass (ISO CuZn39Pb3)

単位 : mm
Dimensions : mm

商品記号 Catalogue Number	歯数 Number of Teeth z	基準円直径 Reference Diameter d	歯先円直径 Tip Diameter da	形 Type	歯幅 Face Width b	穴径 Bore Diameter da(H8)	ハブ外径 Hub Diameter dh	ハブ長さ Hub Projection lh	全長 Overall Length l	ねじ Set Screw		重量 Weight W(g)
										M	ls	
S50B 10K - 1006	10	φ 5	φ 6	K1	10	-	φ 6	45	55	-	-	12.5
S50B 12K - 1007	12	φ 6	φ 7	K1	10	-	φ 7	45	55	-	-	17.1
S50B 14K - 1008	14	φ 7	φ 8	K1	10	-	φ 8	45	55	-	-	22.5
S50B 15K + 0803	15	φ 7.5	φ 8.5	K2	8	φ3	φ 9	10	18	M3	3	7.2
S50B 16K + 0803	16	φ 8	φ 9	K2	8	φ3	φ 9	10	18	M3	3	7.6
S50B 18K + 0803	18	φ 9	φ 10	K2	8	φ3	φ 10	10	18	M3	3	9.7
S50B 20K + 0803	20	φ 10	φ 11	K2	8	φ3	φ 11	10	18	M3	3	12.2
S50B 20B + 0303	20	φ 10	φ 11	B1	3	φ3	φ 8.2	5	8	M3	2.5	3.8
S50B 24B + 0303	24	φ 12	φ 13	B1	3	φ3	φ 10	5	8	M3	2.5	5.6
S50B 25B + 0303	25	φ 12.5	φ 13.5	B1	3	φ3	φ 10	5	8	M3	2.5	5.8
S50B 26B + 0303	26	φ 13	φ 14	B1	3	φ3	φ 10	5	8	M3	2.5	6.1
S50B 28B + 0303	28	φ 14	φ 15	B1	3	φ3	φ 10	5	8	M3	2.5	6.6
S50B 30B + 0303	30	φ 15	φ 16	B1	3	φ3	φ 10	5	8	M3	2.5	7.2
S50B 32B + 0303	32	φ 16	φ 17	B1	3	φ3	φ 10	5	8	M3	2.5	7.8
S50B 35B + 0303	35	φ 17.5	φ 18.5	B1	3	φ3	φ 10	5	8	M3	2.5	8.8
S50B 36B + 0303	36	φ 18	φ 19	B1	3	φ3	φ 10	5	8	M3	2.5	9.2

セットスクリューは付いておりません。
[+] : Gear with threaded hole / without set screw.

許容伝達動力表 曲げ強さ (W)

Allowable transfer capability table (W) Bending Strength

商品記号 Catalogue Numbers	回転速度 (min ⁻¹) revolution/min						
	10	100	200	400	800	1,200	1,500
S50B 10K - 1006	0.12	1.21	2.42	4.85	9.70	14.55	18.18
S50B 12K - 1007	0.17	1.70	3.40	6.79	13.58	20.37	25.47
S50B 14K - 1008	0.22	2.21	4.43	8.85	17.71	26.56	33.20
S50B 15K + 0803	0.20	1.98	3.97	7.94	15.87	23.81	29.76
S50B 16K + 0803	0.22	2.20	4.40	8.81	17.62	26.42	33.03
S50B 18K + 0803	0.26	2.65	5.29	10.59	21.18	31.76	39.71
S50B 20K + 0803	0.31	3.11	6.22	12.43	24.86	37.30	46.62
S50B 20B + 0303	0.12	1.17	2.33	4.66	9.32	13.99	17.48
S50B 24B + 0303	0.15	1.52	3.04	6.08	12.16	18.23	22.79
S50B 25B + 0303	0.16	1.61	3.22	6.44	12.88	19.32	24.15
S50B 26B + 0303	0.17	1.70	3.40	6.80	13.61	20.41	25.43
S50B 28B + 0303	0.19	1.88	3.77	7.54	15.08	22.62	27.85
S50B 30B + 0303	0.21	2.07	4.14	8.28	16.56	24.83	30.23
S50B 32B + 0303	0.23	2.26	4.51	9.03	18.05	27.06	32.60
S50B 35B + 0303	0.25	2.54	5.08	10.16	20.32	30.04	36.08
S50B 36B + 0303	0.26	2.64	5.27	10.54	21.08	31.02	37.22

The above numerical values are equivalent to JGMA formulas as reference only.
動力の換算式は P26 をご参照ください。
Please refer to the conversion formulas of power on page P26.

RoHS 対応

2006年11月生産開始分より欧州 RoHS 指令に対応できる商品を提供しています。
We supplied the KG-products with RoHS compliance of EU to all our valued customers since November 2006

平歯車 SPUR GEARS

モジュール **0.5** 圧力角 20° (並歯)
MODULE 20° PRESSURE ANGLE FULL DEPTH TOOTH

JIS B 1702-1 (ISO) 9~10 級
System of accuracy : JIS B 1702-1(ISO) class 9-10



御注文には必ず “フルネームで商品記号” を明記してください。
Please refer to the catalogue reference while ordering.

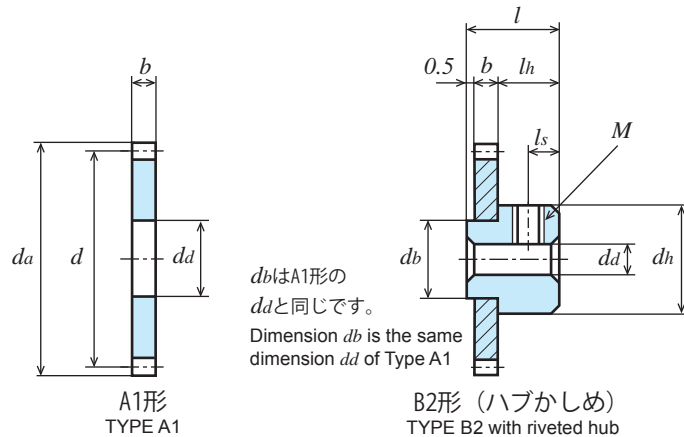

C3713P 快削黄銅板、C3604B 快削黄銅棒 Material : Brass (ISO CuZn38Pb2, CuZn39Pb3)

単位 : mm
Dimensions : mm

商品記号 Catalogue Number	歯数 Number of Teeth <i>z</i>	基準円直径 Reference Diameter <i>d</i>	歯先円直径 Tip Diameter <i>da</i>	形 Type	歯幅 Face Width <i>b</i>	穴径 Bore Diameter <i>da</i> (H8)	ハブ外径 Hub Diameter <i>dh</i>	ハブ長さ Hub Projection <i>lh</i>	全長 Overall Length <i>l</i>	ねじ Set Screw		重量 Weight <i>W</i> (g)
										<i>M</i>	<i>ls</i>	
S50B 40A - 0208	40	φ20	φ21	A1	2	φ8	-	-	2	-	-	4.5
S50B 40B + 0203	40	φ20	φ21	B2	2	φ3	φ10	5	7.5	M3	2.5	8.1
S50B 42A - 0208	42	φ21	φ22	A1	2	φ8	-	-	2	-	-	5.0
S50B 42B + 0203	42	φ21	φ22	B2	2	φ3	φ10	5	7.5	M3	2.5	8.6
S50B 45A - 0208	45	φ22.5	φ23.5	A1	2	φ8	-	-	2	-	-	5.9
S50B 45B + 0203	45	φ22.5	φ23.5	B2	2	φ3	φ10	5	7.5	M3	2.5	9.5
S50B 48A - 0208	48	φ24	φ25	A1	2	φ8	-	-	2	-	-	6.8
S50B 48B + 0203	48	φ24	φ25	B2	2	φ3	φ10	5	7.5	M3	2.5	10.4
S50B 50A - 0208	50	φ25	φ26	A1	2	φ8	-	-	2	-	-	7.5
S50B 50B + 0203	50	φ25	φ26	B2	2	φ3	φ10	5	7.5	M3	2.5	11.1
S50B 55A - 0208	55	φ27.5	φ28.5	A1	2	φ8	-	-	2	-	-	9.2
S50B 55B + 0203	55	φ27.5	φ28.5	B2	2	φ3	φ10	5	7.5	M3	2.5	12.8
S50B 56A - 0208	56	φ28	φ29	A1	2	φ8	-	-	2	-	-	9.6
S50B 56B + 0203	56	φ28	φ29	B2	2	φ3	φ10	5	7.5	M3	2.5	13.2
S50B 58A - 0208	58	φ29	φ30	A1	2	φ8	-	-	2	-	-	10.4
S50B 58B + 0203	58	φ29	φ30	B2	2	φ3	φ10	5	7.5	M3	2.5	14.0
S50B 60A - 0208	60	φ30	φ31	A1	2	φ8	-	-	2	-	-	11.2
S50B 60B + 0203	60	φ30	φ31	B2	2	φ3	φ10	5	7.5	M3	2.5	14.8

A1形の穴径はプレスの抜き出しですので (H8) の公差仕上げになっておりません。

Bore tolerance of H8 but does not apply to type A1 gears due to the press item.

セットスクリューは付いておりません。

[+]: Gear with threaded hole / without set screw.

許容伝達動力表 曲げ強さ (W)

Allowable transfer capability table (W) Bending Strength

商品記号 Catalogue Numbers	回転速度 (min ⁻¹) revolution/min						
	10	100	200	400	800	1,200	1,500
S50B 40A - 0208	0.20	2.01	4.03	8.05	16.10	23.26	27.81
S50B 42A - 0208	0.21	2.14	4.28	8.57	17.13	24.53	29.28
S50B 45A - 0208	0.23	2.33	4.67	9.34	18.68	26.38	31.41
S50B 48A - 0208	0.25	2.53	5.06	10.12	20.22	28.21	33.50
S50B 50A - 0208	0.27	2.66	5.32	10.64	21.14	29.41	34.87
S50B 55A - 0208	0.30	2.99	5.98	11.96	23.38	32.34	38.19
S50B 56A - 0208	0.31	3.06	6.11	12.22	23.82	32.91	38.84
S50B 58A - 0208	0.32	3.19	6.37	12.75	24.70	34.05	40.12
S50B 60A - 0208	0.33	3.32	6.64	13.28	25.57	35.17	41.38

The above numerical values are equivalent to JGMA formulas as reference only.

動力の換算式は P26 をご参照ください。

Please refer to the conversion formulas of power on page P26.

RoHS 対応

2006年11月生産開始日より欧州 RoHS 指令に対応できる商品を提供しています。

We supplied the KG-products with RoHS compliance of EU to all our valued customers since November 2006

平歯車 SPUR GEARS

モジュール 0.5 圧力角 20° (並歯)
MODULE 0.5 20° PRESSURE ANGLE FULL DEPTH TOOTH

JIS B 1702-1 (ISO) 9~10 級
System of accuracy : JIS B 1702-1(ISO) class 9-10

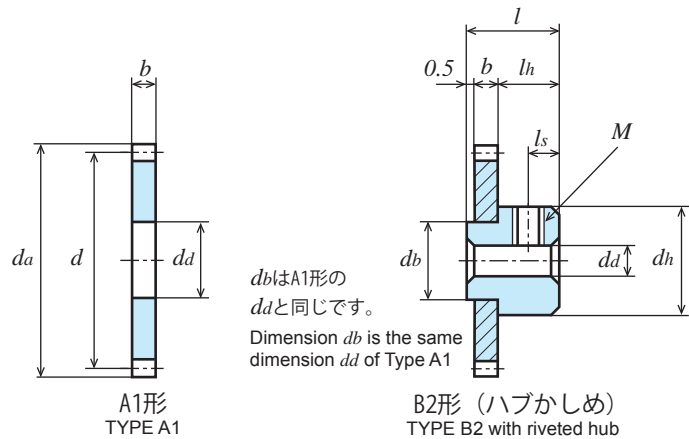

C3713P 快削黄銅板、C3604B 快削黄銅棒 Material : Brass (ISO CuZn38Pb2, CuZn39Pb3)

単位 : mm
Dimensions : mm

商品記号 Catalogue Number	歯数 Number of Teeth <i>z</i>	基準円直径 Reference Diameter <i>d</i>	歯先円直径 Tip Diameter <i>da</i>	形 Type	歯幅 Face Width <i>b</i>	穴径 Bore Diameter <i>da</i> (H8)	ハブ外径 Hub Diameter <i>dh</i>	ハブ長さ Hub Projection <i>lh</i>	全長 Overall Length <i>l</i>	ねじ Set Screw		重量 Weight <i>W</i> (g)
										<i>M</i>	<i>ls</i>	
S50B 62A - 0208	62	φ31	φ32	A1	2	φ8	-	-	2	-	-	12.0
S50B 62B + 0203	62	φ31	φ32	B2	2	φ3	φ10	5	7.5	M3	2.5	15.6
S50B 64A - 0208	64	φ32	φ33	A1	2	φ8	-	-	2	-	-	12.8
S50B 64B + 0203	64	φ32	φ33	B2	2	φ3	φ10	5	7.5	M3	2.5	16.4
S50B 65A - 0208	65	φ32.5	φ33.5	A1	2	φ8	-	-	2	-	-	12.3
S50B 65B + 0203	65	φ32.5	φ33.5	B2	2	φ3	φ10	5	7.5	M3	2.5	16.8
S50B 68A - 0208	68	φ34	φ35	A1	2	φ8	-	-	2	-	-	14.6
S50B 68B + 0203	68	φ34	φ35	B2	2	φ3	φ10	5	7.5	M3	2.5	18.2
S50B 70A - 0208	70	φ35	φ36	A1	2	φ8	-	-	2	-	-	15.5
S50B 70B + 0203	70	φ35	φ36	B2	2	φ3	φ10	5	7.5	M3	2.5	19.1
S50B 72A - 0208	72	φ36	φ37	A1	2	φ8	-	-	2	-	-	16.5
S50B 72B + 0203	72	φ36	φ37	B2	2	φ3	φ10	5	7.5	M3	2.5	20.0
S50B 75A - 0208	75	φ37.5	φ38.5	A1	2	φ8	-	-	2	-	-	17.9
S50B 75B + 0203	75	φ37.5	φ38.5	B2	2	φ3	φ10	5	7.5	M3	2.5	21.5
S50B 80A - 0208	80	φ40	φ41	A1	2	φ8	-	-	2	-	-	20.5
S50B 80B + 0203	80	φ40	φ41	B2	2	φ3	φ10	5	7.5	M3	2.5	24.1

A1形の穴径はプレスの抜き放しですので (H8) の公差仕上げになっておりません。Bore tolerance of H8 but does not apply to type A1 gears due to the press item. セットスクリューは付いておりません。[+]: Gear with threaded hole / without set screw.

許容伝達動力表 曲げ強さ (W)

Allowable transfer capability table (W) Bending Strength

商品記号 Catalogue Numbers	回転速度 (min ⁻¹) revolution/min						
	10	100	200	400	800	1,200	1,500
S50B 62A - 0208	0.35	3.45	6.91	13.81	26.44	36.27	42.62
S50B 64A - 0208	0.36	3.59	7.17	14.34	27.29	37.36	43.83
S50B 65A - 0208	0.37	3.65	7.30	14.61	27.72	37.90	44.43
S50B 66A - 0208	0.37	3.72	7.44	14.88	28.14	38.44	45.03
S50B 68A - 0208	0.39	3.85	7.70	15.41	28.97	39.50	46.21
S50B 70A - 0208	0.40	3.99	7.97	15.94	29.80	40.54	47.36
S50B 72A - 0208	0.41	4.12	8.24	16.48	30.62	41.57	48.50
S50B 75A - 0208	0.43	4.32	8.64	17.28	31.84	43.09	50.17
S50B 80A - 0208	0.47	4.66	9.31	18.63	33.83	45.55	53.44

The above numerical values are equivalent to JGMA formulas as reference only.
動力の換算式は P26 をご参照ください。
Please refer to the conversion formulas of power on page P26.

RoHS 対応

2006年11月生産開始日より欧州 RoHS 指令に対応できる商品を提供しています。
We supplied the KG-products with RoHS compliance of EU to all our valued customers since November 2006

平歯車 SPUR GEARS

モジュール **0.5** 圧力角 20° (並歯)
MODULE 20° PRESSURE ANGLE FULL DEPTH TOOTH

JIS B 1702-1 (ISO) 9~10 級
System of accuracy : JIS B 1702-1(ISO) class 9-10



御注文には必ず “フルネームで商品記号” を明記してください。
Please refer to the catalogue reference while ordering.

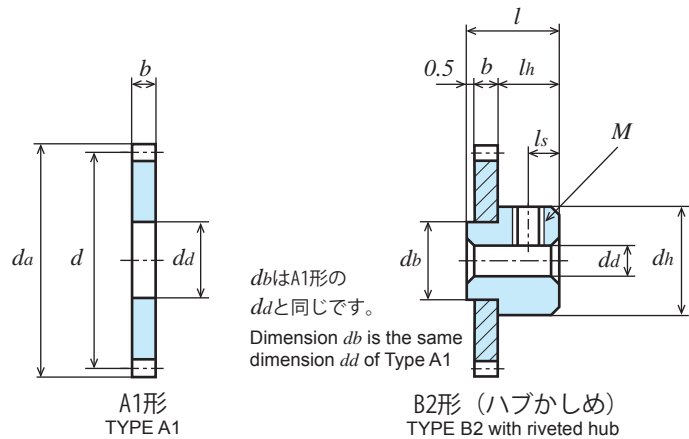

C3713P 快削黄銅板、C3604B 快削黄銅棒 Material : Brass (ISO CuZn38Pb2, CuZn39Pb3)

単位 : mm
Dimensions : mm

商品記号 Catalogue Number	歯数 Number of Teeth <i>z</i>	基準円直径 Reference Diameter <i>d</i>	歯先円直径 Tip Diameter <i>da</i>	形 Type	歯幅 Face Width <i>b</i>	穴径 Bore Diameter <i>da</i> (H8)	ハブ外径 Hub Diameter <i>dh</i>	ハブ長さ Hub Projection <i>lh</i>	全長 Overall Length <i>l</i>	ねじ Set Screw		重量 Weight <i>W</i> (g)
										<i>M</i>	<i>ls</i>	
S50B 84A - 0208	84	φ42	φ43	A1	2	φ 8	-	-	2	-	-	22.7
S50B 84B + 0203	84	φ42	φ43	B2	2	φ 3	φ10	5	7.5	M3	2.5	26.3
S50B 85A - 0208	85	φ42.5	φ43.5	A1	2	φ 8	-	-	2	-	-	23.3
S50B 85B + 0203	85	φ42.5	φ43.5	B2	2	φ 3	φ10	5	7.5	M3	2.5	26.9
S50B 90A - 0208	90	φ45	φ46	A1	2	φ 8	-	-	2	-	-	26.2
S50B 90B + 0203	90	φ45	φ46	B2	2	φ 3	φ10	5	7.5	M3	2.5	29.8
S50B 95A - 0208	95	φ47.5	φ48.5	A1	2	φ 8	-	-	2	-	-	29.3
S50B 95B + 0203	95	φ47.5	φ48.5	B2	2	φ 3	φ10	5	7.5	M3	2.5	32.9
S50B 100A - 0212	100	φ50	φ51	A1	2	φ12	-	-	2	-	-	32.5
S50B 100B + 0203	100	φ50	φ51	B2	2	φ 3	φ15	7	9.5	M3	3.5	36.1
S50B 105A - 0212	105	φ52.5	φ53.5	A1	2	φ12	-	-	2	-	-	36.0
S50B 105B + 0203	105	φ52.5	φ53.5	B2	2	φ 3	φ15	7	9.5	M3	3.5	39.5
S50B 110A - 0212	110	φ55	φ56	A1	2	φ12	-	-	2	-	-	39.5
S50B 110B + 0203	110	φ55	φ56	B2	2	φ 3	φ15	7	9.5	M3	3.5	43.1

A1形の穴径はプレスの抜き放しですので (H8) の公差仕上げになっておりません。

Bore tolerance of H8 but does not apply to type A1 gears due to the press item.

セットスクリューは付いておりません。

[+]: Gear with threaded hole / without set screw.

許容伝達動力表 曲げ強さ (W)

Allowable transfer capability table (W) Bending Strength

商品記号 Catalogue Numbers	回転速度 (min ⁻¹) revolution/min						
	10	100	200	400	800	1,200	1,500
S50B 84A - 0208	0.49	4.92	9.84	19.68	35.34	47.40	56.14
S50B 85A - 0208	0.50	4.99	9.98	19.95	35.72	47.87	56.82
S50B 90A - 0208	0.53	5.33	10.65	21.30	37.61	50.15	60.21
S50B 95A - 0208	0.57	5.66	11.33	22.65	39.44	52.36	63.55
S50B 100A - 0212	0.60	6.00	12.00	23.83	41.24	55.09	66.86
S50B 105A - 0212	0.63	6.34	12.68	24.98	42.98	57.85	70.12
S50B 110A - 0212	0.67	6.68	13.36	26.12	44.69	60.59	73.34

The above numerical values are equivalent to JGMA formulas as reference only.

動力の換算式は P26 をご参照ください。

Please refer to the conversion formulas of power on page P26.

RoHS 対応

2006年11月生産開始日より欧州 RoHS 指令に対応できる商品を提供しています。

We supplied the KG-products with RoHS compliance of EU to all our valued customers since November 2006

平歯車 SPUR GEARS

MODULE 0.5 圧力角 20° (並歯)
20° PRESSURE ANGLE FULL DEPTH TOOTH

JIS B 1702-1 (ISO) 8~9 級
System of accuracy : JIS B 1702-1(ISO) class 8-9



New **ねじを2箇所 (120°配) にしました。**
締結力が1.6倍になりました。
New item with two threaded holes (120°)
Tightening power increased by 1.6 times.

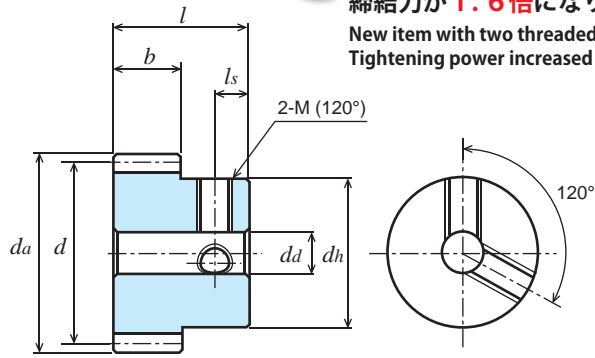

B1形
TYPE B1

S45C 機械構造用炭素鋼 (JIS G 4051) Material : Carbon Steel (ISO C45)

単位 : mm
Dimensions : mm

商品記号 Catalogue Number	歯数 Number of Teeth z	基準円直径 Reference Diameter d	歯先円直径 Tip Diameter da	形 Type	歯幅 Face Width b	穴径 Bore Diameter da(H8)	ハブ外径 Hub Diameter dh	ハブ長さ Hub Projection lh	全長 Overall Length l	ねじ Set Screw		重量 Weight W(g)
										2-M(120°)	ls	
S50S 10K - 1006	10	φ 5	φ 6	K1	10	-	φ 6	45	55	-	-	11.5
S50S 12K - 1007	12	φ 6	φ 7	K1	10	-	φ 7	45	55	-	-	15.8
S50S 14K - 1008	14	φ 7	φ 8	K1	10	-	φ 8	45	55	-	-	20.8
S50S 15K * 0803	15	φ 7.5	φ 8.5	K2	8	φ3	φ 8.5	10	18	2-M3	3	6.0
S50S 16K * 0803	16	φ 8	φ 9	K2	8	φ3	φ 9	10	18	2-M3	3	6.9
S50S 18K * 0804	18	φ 9	φ10	K2	8	φ4	φ10	10	18	2-M3	3	8.1
S50S 20K * 0804	20	φ10	φ11	K2	8	φ4	φ11	10	18	2-M3	3	10.3
S50S 21K * 0804	21	φ10.5	φ11.5	K2	8	φ4	φ11.5	10	18	2-M3	3	11.5
S50S 22K * 0804	22	φ11	φ12	K2	8	φ4	φ12	10	18	2-M3	3	12.7
S50S 24K * 0804	24	φ12	φ13	K2	8	φ4	φ13	10	18	2-M3	3	15.4
S50S 25B * 0804	25	φ12.5	φ13.5	B1	8	φ4	φ10	8	16	2-M3	4	10.8
S50S 26B * 0804	26	φ13	φ14	B1	8	φ4	φ10	8	16	2-M3	4	11.4
S50S 27B * 0804	27	φ13.5	φ14.5	B1	8	φ4	φ10	8	16	2-M3	4	12.1
S50S 28B * 0804	28	φ14	φ15	B1	8	φ4	φ10	8	16	2-M3	4	12.8
S50S 30B * 0805	30	φ15	φ16	B1	8	φ5	φ12	8	16	2-M3	4	15.4

【*】(アスタ)にはセットスクリーが2個付いております。
[*]: Gear with two threaded holes / with two set screws.

許容伝達動力表 曲げ強さ (W)

Allowable transfer capability table (W) Bending Strength

商品記号 Catalogue Numbers	回転速度 (min ⁻¹) revolution/min						
	10	100	200	400	800	1,200	1,500
S50S 10K - 1006	0.62	6.19	12.38	24.77	49.53	74.30	92.87
S50S 12K - 1007	0.85	8.49	16.98	33.96	67.91	101.87	127.33
S50S 14K - 1008	1.11	11.07	22.13	44.26	88.53	132.79	165.99
S50S 15K * 0803	0.99	9.92	19.84	39.68	79.37	119.05	148.81
S50S 16K * 0803	1.10	11.01	22.02	44.04	88.08	132.12	165.15
S50S 18K * 0804	1.32	13.24	26.47	52.94	105.88	158.82	198.53
S50S 20K * 0804	1.55	15.54	31.08	62.16	124.32	186.48	233.10
S50S 21K * 0804	1.67	16.70	33.40	66.81	133.62	200.43	250.53
S50S 22K * 0804	1.79	17.88	35.76	71.52	143.04	214.57	268.21
S50S 24K * 0804	2.03	20.26	40.52	81.04	162.07	243.11	303.88
S50S 25B * 0804	2.15	21.46	42.93	85.86	172.72	257.57	321.97
S50S 26B * 0804	2.27	22.68	45.36	90.71	181.43	272.14	339.11
S50S 27B * 0804	2.39	23.90	47.80	95.60	191.20	286.80	355.29
S50S 28B * 0804	2.51	25.13	50.26	100.52	201.03	301.55	371.39
S50S 30B * 0805	2.76	27.59	55.18	110.37	220.74	331.11	403.12

The above references are JGMA standard.

動力の換算式は P26 をご参照ください。

Please refer to the conversion formulas of power on page P26.

平歯車 SPUR GEARS

モジュール **0.5** 圧力角 20° (並歯)
MODULE 20° PRESSURE ANGLE FULL DEPTH TOOTH

JIS B 1702-1 (ISO) 8級 (高周波焼入品: 9級)
System of accuracy: JIS B 1702-1(ISO) class 8
(Induction hardened products: class 9)



御注文には必ず“フルネームで商品記号”を明記してください。
Please refer to the catalogue reference while ordering.

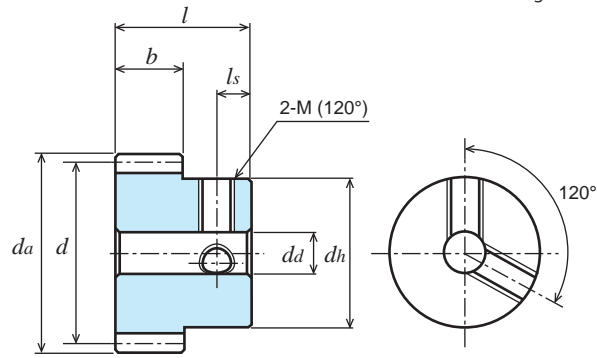

B1形
TYPE B1

S45C 機械構造用炭素鋼 (JIS G 4051) Material: Carbon Steel (ISO C45)

単位: mm
Dimensions: mm

商品記号 Catalogue Number	歯数 Number of Teeth z	基準円直径 Reference Diameter d	歯先円直径 Tip Diameter da	形 Type	歯幅 Face Width b	穴径 Bore Diameter da(H7)	ハブ外径 Hub Diameter dh	ハブ長さ Hub Projection lh	全長 Overall Length l	ねじ Set Screw		重量 Weight W(g)
										2-M(120°)	ls	
● S50S 30BF - 0504	30	φ15	φ16	B1	5	φ4(H8)	φ12	8	13	-	-	12.7
● S50S 30B - 0504H	30	φ15	φ16	B1	5	φ4(H※)	φ12	8	13	-	-	12.7
S50S 30B * 0805	30	φ15	φ16	B1	8	φ5	φ12	8	16	2-M3	4	15.4
S50S 32B * 0505	32	φ16	φ17	B1	5	φ5	φ12	8	13	2-M3	4	12.7
S50S 35B * 0505	35	φ17.5	φ18.5	B1	5	φ5	φ12	8	13	2-M3	4	14.2
S50S 36B * 0505	36	φ18	φ19	B1	5	φ5	φ12	8	13	2-M3	4	14.8
● S50S 40BF - 0504	40	φ20	φ21	B1	5	φ4(H8)	φ15	8	13	-	-	22.1
● S50S 40B - 0504H	40	φ20	φ21	B1	5	φ4(H※)	φ15	8	13	-	-	22.1
S50S 40B * 0505	40	φ20	φ21	B1	5	φ5	φ15	8	13	2-M3	4	21.0
S50S 42B * 0505	42	φ21	φ22	B1	5	φ5	φ15	8	13	2-M3	4	22.3
S50S 44B * 0505	44	φ22	φ23	B1	5	φ5	φ15	8	13	2-M3	4	23.6
S50S 45B * 0505	45	φ22.5	φ23.5	B1	5	φ5	φ15	8	13	2-M3	4	24.3

●の商品は新商品です。
Products with ● marks are new item.

【*】(アスタ)にはセットスクリューが2個付いております。
[*]: Gear with two threaded holes / with two set screws.

カタログ記号の末尾に【H】を付した商品は歯部高周波焼入済です。Gear tooth surface completed with induction hardening, Hardness HRC47 to 53.

※
歯部高周波焼入後の穴修正は行っていません。Bore correcting after induction hardening is not completed.
追加加工の際は、追加加工時の注意をご参照ください。Please refer to Precaution for additional process when additional process.

許容伝達動力表 曲げ強さ (W)

Allowable transfer capability table (W) Bending Strength

商品記号 Catalogue Numbers	回転速度 (min ⁻¹) revolution/min						
	10	100	200	400	800	1,200	1,500
S50S30BF - 0504	1.73	17.28	34.56	69.11	138.22	207.34	252.89
S50S30B - 0504H	1.83	18.30	36.59	73.18	146.37	219.55	267.95
S50S 30B * 0805	2.76	27.59	55.18	110.37	220.74	331.11	403.12
S50S 32B * 0505	1.88	18.81	37.61	75.22	150.44	225.49	271.63
S50S 35B * 0505	2.12	21.17	42.34	84.68	169.36	250.30	300.66
S50S 36B * 0505	2.20	21.96	43.93	87.85	175.71	258.48	310.20
S50S40BF - 0504	2.51	25.13	50.26	100.53	201.05	290.27	347.13
S50S40B - 0504H	2.66	26.62	53.24	106.48	212.96	308.58	370.49
S50S 40B * 0505	2.52	25.16	50.32	100.65	201.29	290.74	347.65
S50S 42B * 0505	2.68	26.77	53.55	107.09	214.19	306.59	365.96
S50S 44B * 0505	2.84	28.37	56.75	113.49	226.99	322.02	383.71
S50S 45B * 0505	2.92	29.18	58.37	116.74	233.47	329.75	392.59

The above references are JGMA standard.

動力の換算式はP26をご参照ください。Please refer to the conversion fomulas of power on page P26.

許容伝達動力表 歯面強さ (W)

Allowable transfer capability table (W) Surface Durability

商品記号 Catalogue Numbers	回転速度 (min ⁻¹) revolution/min						
	10	100	200	400	800	1,200	1,500
S50S30BF - 0504	0.08	0.84	1.68	3.77	7.54	11.31	12.57
S50S30B - 0504H	0.40	4.39	9.07	18.66	38.52	58.75	72.53
S50S 30B * 0805	-	-	-	-	-	-	-
S50S 32B * 0505	-	-	-	-	-	-	-
S50S 35B * 0505	-	-	-	-	-	-	-
S50S 36B * 0505	-	-	-	-	-	-	-
S50S40BF - 0504	0.16	1.57	3.14	6.70	13.40	18.85	23.56
S50S40B - 0504H	0.73	8.03	16.55	34.14	70.37	103.74	125.76
S50S 40B * 0505	-	-	-	-	-	-	-
S50S 42B * 0505	-	-	-	-	-	-	-
S50S 44B * 0505	-	-	-	-	-	-	-
S50S 45B * 0505	-	-	-	-	-	-	-

目次
CONTENTS

インフォメーション
INFORMATION

ギヤボックス
GEAR BOXES

ノーバッキングギヤ
ANTI BACKLASH SPUR GEARS

歯研歯車
GROUND SPUR GEARS

平歯車
SPUR GEARS

内歯車
INTERNAL GEARS

歯研ラック
GROUND RACKS

ラック
RACKS

ハニカム・スクリューギヤ
HELICAL GEARS AND SCREW GEARS

ウォーム・ウォームホイール
WORMS AND WORM WHEELS

かさ歯車
BEVEL GEARS

スプロケット
SPROCKETS

技術データ
REFERENCE DATA

平歯車 SPUR GEARS

モジュール 0.5 圧力角 20° (並歯)
MODULE 0.5 20° PRESSURE ANGLE FULL DEPTH TOOTH

JIS B 1702-1 (ISO) 8級 (高周波焼入品: 9級)
System of accuracy: JIS B 1702-1(ISO) class 8
(Induction hardened products: class 9)



御注文には必ず“フルネームで商品記号”を明記してください。
Please refer to the catalogue reference while ordering.

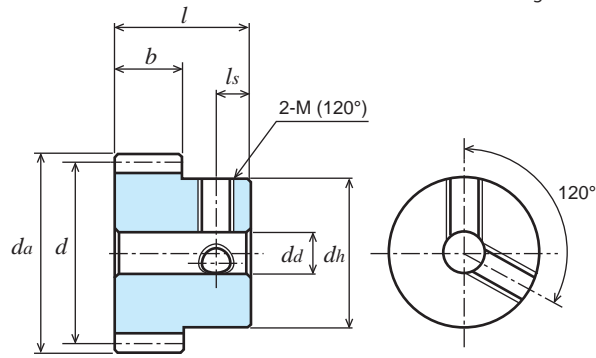

B1形
TYPE B1

S45C 機械構造用炭素鋼 (JIS G 4051) Material: Carbon Steel (ISO C45)

単位: mm
Dimensions: mm

商品記号 Catalogue Number	歯数 Number of Teeth z	基準円直径 Reference Diameter d	歯先円直径 Tip Diameter da	形 Type	歯幅 Face Width b	穴径 Bore Diameter da(H7)	ハブ外径 Hub Diameter dh	ハブ長さ Hub Projection lh	全長 Overall Length l	ねじ Set Screw		重量 Weight W(g)
										2-M(120°)	ls	
S50S 48B * 0505	48	φ24	φ25	B1	5	φ5	φ15	8	13	2-M3	4	26.4
● S50S 50BF - 0504	50	φ25	φ26	B1	5	φ4(H8)	φ18	8	13	-	-	33.9
● S50S 50B - 0504H	50	φ25	φ26	B1	5	φ4(H※)	φ18	8	13	-	-	33.9
S50S 50B * 0505	50	φ25	φ26	B1	5	φ5	φ15	8	13	2-M3	4	27.9
S50S 52B * 0505	52	φ26	φ27	B1	5	φ5	φ15	8	13	2-M3	4	29.5
S50S 54B * 0505	54	φ27	φ28	B1	5	φ5	φ15	8	13	2-M3	4	31.1
S50S 55B * 0505	55	φ27.5	φ28.5	B1	5	φ5	φ15	8	13	2-M3	4	32.0
S50S 56B * 0505	56	φ28	φ29	B1	5	φ5	φ15	8	13	2-M3	4	32.8
● S50S 60BF - 0505	60	φ30	φ31	B1	5	φ5	φ22	8	13	-	-	49.5
● S50S 60B - 0505H	60	φ30	φ31	B1	5	φ5(H※)	φ22	8	13	-	-	49.5
S50S 60B * 0506	60	φ30	φ31	B1	5	φ6	φ18	8	13	2-M4	4	39.9
S50S 64B * 0506	64	φ32	φ33	B1	5	φ6	φ18	8	13	2-M4	4	43.7

●の商品は新商品です。
Products with ● marks are new item.

【*】(アスタ)にはセットスクリューが2個付いております。
[*]: Gear with two threaded holes / with two set screws.

カタログ記号の末尾に【H】を付した商品は歯部高周波焼入済です。Gear tooth surface completed with induction hardening, Hardness HRC47 to 53.

※
歯部高周波焼入後の穴修正は行っていません。Bore correcting after induction hardening is not completed.
追加加工の際は、追加加工時の注意をご参照ください。Please refer to Precaution for additional process when additional process.

許容伝達動力表 曲げ強さ (W)

Allowable transfer capability table (W) Bending Strength

商品記号 Catalogue Numbers	回転速度 (min ⁻¹) revolution/min						
	10	100	200	400	800	1,200	1,500
S50S 48B * 0505	3.16	31.63	63.25	126.50	252.80	352.63	418.79
S50S 50BF - 0504	3.31	33.09	66.18	132.36	263.04	365.67	433.52
S50S 50B - 0504H	3.51	35.11	70.23	140.46	279.14	390.97	465.49
S50S 50B * 0505	3.33	33.26	66.52	133.04	264.20	367.63	435.89
S50S 52B * 0505	3.49	34.90	69.80	139.60	275.51	382.44	452.72
S50S 54B * 0505	3.65	36.54	73.08	146.17	286.71	397.03	469.26
S50S 55B * 0505	3.74	37.37	74.73	149.46	292.27	404.26	477.43
S50S 56B * 0505	3.82	38.19	76.38	152.76	297.80	411.43	485.53
S50S 60BF - 0505	4.13	41.26	82.52	165.03	318.33	437.29	515.20
S50S 60B - 0505H	4.37	43.75	87.50	175.00	338.17	468.53	553.85
S50S 60B * 0506	4.15	41.50	83.00	165.99	319.68	439.63	517.25
S50S 64B * 0506	4.48	44.82	89.64	179.28	341.14	467.04	547.92

The above references are JGMA standard.

動力の換算式は P26 をご参照ください。Please refer to the conversion fomulas of power on page P26.

許容伝達動力表 歯面強さ (W)

Allowable transfer capability table (W) Surface Durability

商品記号 Catalogue Numbers	回転速度 (min ⁻¹) revolution/min						
	10	100	200	400	800	1,200	1,500
S50S 48B * 0505	-	-	-	-	-	-	-
S50S 50BF - 0504	0.26	2.62	5.24	10.47	20.94	30.16	36.13
S50S 50B - 0504H	1.16	12.82	26.42	54.45	111.54	159.11	191.35
S50S 50B * 0505	-	-	-	-	-	-	-
S50S 52B * 0505	-	-	-	-	-	-	-
S50S 54B * 0505	-	-	-	-	-	-	-
S50S 55B * 0505	-	-	-	-	-	-	-
S50S 56B * 0505	-	-	-	-	-	-	-
S50S 60BF - 0505	0.38	3.77	7.54	15.50	30.16	41.47	50.26
S50S 60B - 0505H	1.70	18.78	38.70	79.82	158.99	224.13	267.65
S50S 60B * 0506	-	-	-	-	-	-	-
S50S 64B * 0506	-	-	-	-	-	-	-

平歯車 SPUR GEARS

モジュール **0.5** 圧力角 20° (並歯)
MODULE 20° PRESSURE ANGLE FULL DEPTH TOOTH

JIS B 1702-1 (ISO) 8級 (高周波焼入品: 9級)
System of accuracy: JIS B 1702-1(ISO) class 8
(Induction hardened products: class 9)



New **ねじを2箇所 (120°配) にしました。**
締結力が **1.6倍** になりました。
New item with two threaded holes (120°)
Tightening power increased by 1.6 times.

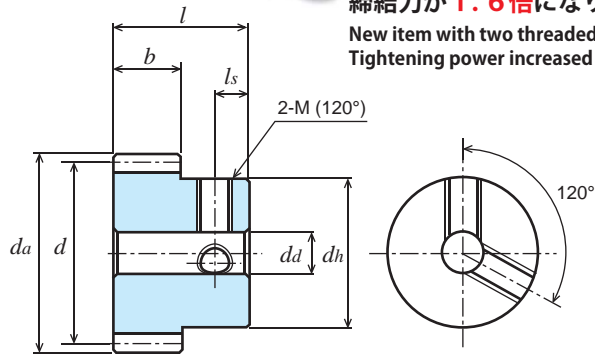

B1形
TYPE B1

S45C 機械構造用炭素鋼 (JIS G 4051) Material: Carbon Steel (ISO C45)

単位: mm
Dimensions: mm

商品記号 Catalogue Number	歯数 Number of Teeth z	基準円直径 Reference Diameter d	歯先円直径 Tip Diameter da	形 Type	歯幅 Face Width b	穴径 Bore Diameter da(H7)	ハブ外径 Hub Diameter dh	ハブ長さ Hub Projection lh	全長 Overall Length l	ねじ Set Screw		重量 Weight W(g)
										2-M(120°)	ls	
● S50S 70BF - 0505	70	φ35	φ36	B1	5	φ5	φ25	8	13	-	-	66.5
● S50S 70B - 0505H	70	φ35	φ36	B1	5	φ5(H※)	φ25	8	13	-	-	66.5
S50S 70B * 0506	70	φ35	φ36	B1	5	φ6	φ18	8	13	2-M4	4	49.9
S50S 72B * 0506	72	φ36	φ37	B1	5	φ6	φ18	8	13	2-M4	4	52.1
S50S 75B * 0506	75	φ37.5	φ38.5	B1	5	φ6	φ18	8	13	2-M4	4	55.5
● S50S 80BF - 0506	80	φ40	φ41	B1	5	φ6	φ28	8	13	-	-	85.0
● S50S 80B - 0506H	80	φ40	φ41	B1	5	φ6(H※)	φ28	8	13	-	-	85.0
S50S 80B * 0508	80	φ40	φ41	B1	5	φ8	φ22	8	13	2-M4	4	67.0
● S50S 90BF - 0506	90	φ45	φ46	B1	5	φ6	φ32	8	13	-	-	109.9
● S50S 90B - 0506H	90	φ45	φ46	B1	5	φ6(H※)	φ32	8	13	-	-	109.9
S50S 90B * 0508	90	φ45	φ46	B1	5	φ8	φ22	8	13	2-M4	4	80.1
S50S 96B * 0508	96	φ48	φ49	B1	5	φ8	φ22	8	13	2-M4	4	88.7

●の商品は新商品です。
Products with ● marks are new item.

【*】(アスタ)にはセットスクリーが2個付いております。
[*]: Gear with two threaded holes / with two set screws.

カタログ記号の末尾に【H】を付した商品は歯部高周波焼入済です。Gear tooth surface completed with induction hardening, Hardness HRC47 to 53.

※ 歯部高周波焼入後の穴修正は行っていません。Bore correcting after induction hardening is not completed.

追加加工の際は、追加加工時の注意をご参照ください。Please refer to Precaution for additional process when additional process.

許容伝達動力表 曲げ強さ (W)

Allowable transfer capability table (W) Bending Strength

商品記号 Catalogue Numbers	回転速度 (min ⁻¹) revolution/min						
	10	100	200	400	800	1,200	1,500
S50S70BF - 0505	4.94	49.53	99.06	198.12	370.27	503.89	587.45
S50S70B - 0505H	5.25	52.48	104.97	209.94	394.79	541.28	635.58
S50S 70B * 0506	4.98	49.82	99.65	199.30	372.55	506.74	592.05
S50S 72B * 0506	5.15	51.50	102.99	205.99	382.81	519.61	606.27
S50S 75B * 0506	5.40	54.01	108.02	216.04	398.01	538.57	627.16
S50S80BF - 0506	5.78	57.80	115.61	231.21	419.70	565.46	662.85
S50S80B - 0506H	6.13	61.27	122.54	245.08	448.83	609.43	718.51
S50S 80B * 0508	5.82	58.21	116.42	232.85	422.85	569.31	668.04
S50S90BF - 0506	6.61	66.08	132.15	264.30	466.61	622.01	746.10
S50S90B - 0506H	7.00	70.02	140.03	280.07	499.82	672.64	809.74
S50S 90B * 0508	6.66	66.56	133.13	266.25	470.10	626.91	752.57
S50S 96B * 0508	7.16	71.63	143.26	286.28	497.59	660.77	802.70

The above references are JGMA standard.

動力の換算式は P26 をご参照ください。Please refer to the conversion formulas of power on page P26.

許容伝達動力表 歯面強さ (W)

Allowable transfer capability table (W) Surface Durability

商品記号 Catalogue Numbers	回転速度 (min ⁻¹) revolution/min						
	10	100	200	400	800	1,200	1,500
S50S70BF - 0505	0.52	5.24	10.47	21.36	40.21	56.55	65.97
S50S70B - 0505H	2.34	25.93	53.46	110.22	213.68	298.20	353.60
S50S 70B * 0506	-	-	-	-	-	-	-
S50S 72B * 0506	-	-	-	-	-	-	-
S50S 75B * 0506	-	-	-	-	-	-	-
S50S80BF - 0506	0.69	7.02	14.03	28.48	52.78	71.63	86.39
S50S80B - 0506H	3.10	34.30	70.71	145.80	275.28	380.47	452.97
S50S 80B * 0508	-	-	-	-	-	-	-
S50S90BF - 0506	0.89	8.90	18.01	36.44	65.34	89.22	109.95
S50S90B - 0506H	3.97	43.90	90.51	186.62	343.32	470.22	571.65
S50S 90B * 0508	-	-	-	-	-	-	-
S50S 96B * 0508	-	-	-	-	-	-	-

平歯車 SPUR GEARS

モジュール 0.5 圧力角 20° (並歯)
MODULE 0.5 20° PRESSURE ANGLE FULL DEPTH TOOTH

JIS B 1702-1 (ISO) 8級 (高周波焼入品: 9級)
System of accuracy: JIS B 1702-1(ISO) class 8
(Induction hardened products: class 9)



New **ねじを2箇所 (120°配) にしました。**
締結力が**1.6倍**になりました。
New item with two threaded holes (120°)
Tightening power increased by 1.6 times.

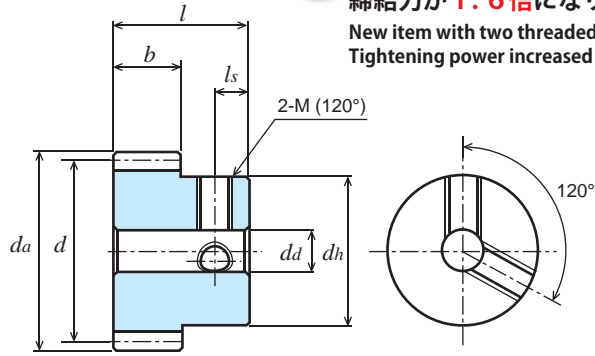

B1形
TYPE B1

S45C 機械構造用炭素鋼 (JIS G 4051) Material: Carbon Steel (ISO C45)

単位: mm
Dimensions: mm

商品記号 Catalogue Number	歯数 Number of Teeth z	基準円直径 Reference Diameter d	歯先円直径 Tip Diameter da	形 Type	歯幅 Face Width b	穴径 Bore Diameter da(H7)	ハブ外径 Hub Diameter dh	ハブ長さ Hub Projection lh	全長 Overall Length l	ねじ Set Screw		重量 Weight W(g)
										2-M(120°)	ls	
● S50S 100BF - 0506	100	φ50	φ51	B1	5	φ6	φ35	8	13	-	-	134.4
● S50S 100B - 0506H	100	φ50	φ51	B1	5	φ6(H※)	φ35	8	13	-	-	134.4
S50S 100B * 0508	100	φ50	φ51	B1	5	φ8	φ25	8	13	2-M4	4	101.4
S50S 110B * 0508	110	φ55	φ56	B1	5	φ8	φ25	8	13	2-M4	4	117.6
● S50S 120BF - 0506	120	φ60	φ61	B1	5	φ6	φ42	8	13	-	-	194.9
● S50S 120B - 0506H	120	φ60	φ61	B1	5	φ6(H※)	φ42	8	13	-	-	194.9
S50S 120B * 0508	120	φ60	φ61	B1	5	φ8	φ25	8	13	2-M4	4	135.4

● の商品は新商品です。
Products with ● marks are new item.

【*】(アスタ)にはセットスクリーが2個付いております。
[*]: Gear with two threaded holes / with two set screws.

カタログ記号の末尾に【H】を付した商品は歯部高周波焼入済です。Gear tooth surface completed with induction hardening, Hardness HRC47 to 53.

※
歯部高周波焼入後の穴修正は行っていません。Bore correcting after induction hardening is not completed.
追加加工の際は、追加加工時の注意をご参照ください。Please refer to Precaution for additional process when additional process.

許容伝達動力表 曲げ強さ (W)

Allowable transfer capability table (W) Bending Strength

商品記号 Catalogue Numbers	回転速度 (min ⁻¹) revolution/min						
	10	100	200	400	800	1,200	1,500
S50S 100BF - 0506	7.43	74.35	148.70	295.30	511.01	683.58	829.35
S50S 100B - 0506H	7.89	78.86	157.73	313.44	548.96	739.84	899.76
S50S 100B * 0508	7.50	75.01	150.02	297.93	515.45	688.64	835.69
S50S 110B * 0508	8.35	83.48	166.96	326.48	558.60	757.32	916.71
S50S 120BF - 0506	9.11	91.10	182.20	351.01	593.95	816.78	986.42
S50S 120B - 0506H	9.66	96.64	193.27	373.48	640.88	886.77	1073.32
S50S 120B * 0508	9.20	91.98	183.95	354.27	599.68	824.59	995.68

The above references are JGMA standard.

動力の換算式は P26 をご参照ください。Please refer to the conversion formulas of power on page P26.

許容伝達動力表 歯面強さ (W)

Allowable transfer capability table (W) Surface Durability

商品記号 Catalogue Numbers	回転速度 (min ⁻¹) revolution/min						
	10	100	200	400	800	1,200	1,500
S50S 100BF - 0506	1.11	11.20	22.41	45.24	79.58	110.58	136.65
S50S 100B - 0506H	4.95	54.75	112.87	231.21	417.47	572.64	703.28
S50S 100B * 0508	-	-	-	-	-	-	-
S50S 110B * 0508	-	-	-	-	-	-	-
S50S 120BF - 0506	1.63	16.44	33.09	64.50	112.25	159.59	197.91
S50S 120B - 0506H	7.25	80.21	165.37	329.41	582.65	820.78	1003.21
S50S 120B * 0508	-	-	-	-	-	-	-

Memo

目次
CONTENTS

インフォメーション
INFORMATION

ギヤボックス
GEAR BOXES

ノーバッキングギヤ
ANTI BACKLASH SPUR GEARS

歯研平歯
GROUND SPUR GEARS

平歯
SPUR GEARS

内歯
INTERNAL GEARS

歯ラック
GROUND RACKS

ラック
RACKS

へりかき・スクリューギヤ
HELICAL GEARS AND SCREW GEARS

ワーム・ワームホイール
WORMS AND WORM WHEELS

かみ歯
BEVEL GEARS

スプロケット
SPROCKETS

技術資料
REFERENCE DATA

ステンレス平歯車

SPUR GEARS

モジュール **0.75** 圧力角 20° (並歯)
 MODULE 20° PRESSURE ANGLE FULL DEPTH TOOTH

JIS B 1702-1 (ISO) 9 級
 System of accuracy : JIS B 1702-1(ISO) class 9



御注文には必ず“フルネームで商品記号”を明記してください。
 Please refer to the catalogue reference while ordering.

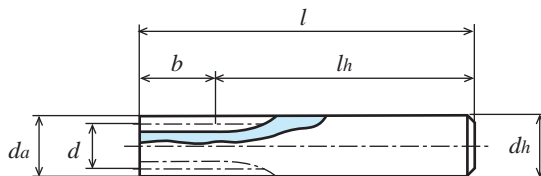

K1形
TYPE K1

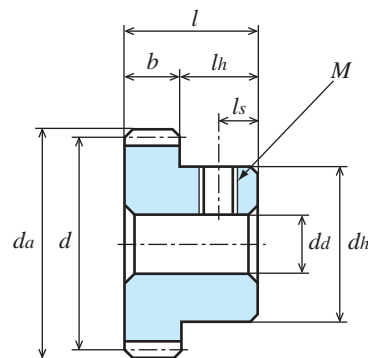

B1形
TYPE B1

SUS304 ステンレス鋼棒 (JIS G 4303)

Material : Stainless Steel SUS304 (JIS G 4303)

単位 : mm
 Dimensions : mm

商品記号 Catalogue Number	歯数 Number of Teeth z	基準円直径 Reference Diameter d	歯先円直径 Tip Diameter da	形 Type	歯幅 Face Width b	穴径 Bore Diameter da(H8)	ハブ外径 Hub Diameter dh	ハブ長さ Hub Projection lh	全長 Overall Length l	ねじ Set Screw		重量 Weight W(g)
										M	ls	
S75SU 10K - 0809	10	φ 7.5	φ 9	K1	8	-	φ 9	47	55	-	-	26.5
S75SU 14K + 0805	14	φ 10.5	φ 12	K2	8	φ5	φ12	12	20	M3	3	13.0
S75SU 15K + 0805	15	φ 11.25	φ 12.75	K2	8	φ5	φ12.75	12	20	M3	3	15.2
S75SU 16B + 0805	16	φ 12	φ 13.5	B1	8	φ5	φ10	7	15	M3	3.5	9.1
S75SU 18B + 0805	18	φ 13.5	φ 15	B1	8	φ5	φ11	7	15	M3	3.5	11.9
S75SU 20B + 0806	20	φ 15	φ 16.5	B1	8	φ6	φ12	7	15	M4	3.5	13.9
S75SU 21B + 0806	21	φ 15.75	φ 17.25	B1	8	φ6	φ12	7	15	M4	3.5	15.1
S75SU 22B + 0806	22	φ 16.5	φ 18	B1	8	φ6	φ12	7	15	M4	3.5	16.3
S75SU 24B + 0806	24	φ 18	φ 19.5	B1	8	φ6	φ14	7	15	M4	3.5	21.0
S75SU 25B + 0806	25	φ 18.75	φ 20.25	B1	8	φ6	φ14	7	15	M4	3.5	22.4
S75SU 26B + 0806	26	φ 19.5	φ 21	B1	8	φ6	φ14	7	15	M4	3.5	23.8
S75SU 28B + 0806	28	φ 21	φ 22.5	B1	8	φ6	φ14	7	15	M4	3.5	26.9
S75SU 30B + 0806	30	φ 22.5	φ 24	B1	8	φ6	φ14	7	15	M4	3.5	31.3

SUS304 の商品にはセットスクリューは付いておりません。
 [+] : Gear with threaded hole / without set screw.

許容伝達動力表 曲げ強さ (W)

Allowable transfer capability table (W) Bending Strength

商品記号 Catalogue Numbers	回転速度 (min ⁻¹) revolution/min						
	10	100	200	400	800	1,200	1,500
S75SU 10K - 0809	0.55	5.46	10.91	21.82	43.64	65.46	81.83
S75SU 12K - 0811	0.76	7.64	15.28	30.56	61.12	91.68	114.60
S75SU 14K + 0805	1.00	9.96	19.92	39.84	79.67	119.51	149.39
S75SU 15K + 0805	1.12	11.16	22.32	44.64	89.29	133.93	167.41
S75SU 16B + 0805	1.24	12.39	24.77	49.54	99.09	148.63	185.79
S75SU 18B + 0805	1.49	14.89	29.78	59.56	119.12	178.67	221.34
S75SU 20B + 0806	1.75	17.48	34.97	69.93	139.86	209.79	255.42
S75SU 21B + 0806	1.88	18.79	37.58	75.16	150.32	225.48	272.18
S75SU 22B + 0806	2.01	20.12	40.23	80.46	160.93	240.07	288.91
S75SU 24B + 0806	2.28	22.79	45.58	91.17	182.33	268.23	321.89
S75SU 25B + 0806	2.41	24.15	48.30	96.59	193.18	282.23	338.23
S75SU 26B + 0806	2.55	25.51	51.03	102.05	204.11	296.15	354.44
S75SU 28B + 0806	2.83	28.27	56.54	113.08	226.16	323.73	386.41
S75SU 30B + 0806	3.10	31.04	62.08	124.17	248.33	350.73	417.57

The above numerical values are equivalent to JGMA formulas as reference only.
 動力の換算式は P26 をご参照ください。
 Please refer to the conversion formulas of power on page P26.

ステンレス平歯車

SPUR GEARS

モジュール **0.75** 圧力角 20° (並歯)
 MODULE 20° PRESSURE ANGLE FULL DEPTH TOOTH

JIS B 1702-1 (ISO) 9級
 System of accuracy : JIS B 1702-1(ISO) class 9

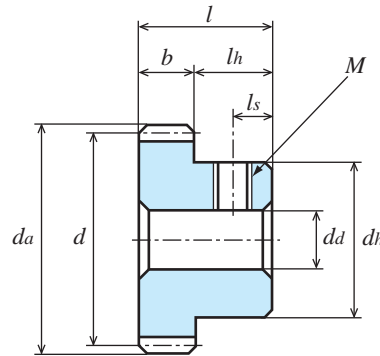

B1形
TYPE B1

SUS304 ステンレス鋼棒 (JIS G 4303)

Material : Stainless Steel SUS304 (JIS G 4303)

単位 : mm
Dimensions : mm

商品記号 Catalogue Number	歯数 Number of Teeth z	基準円直径 Reference Diameter d	歯先円直径 Tip Diameter da	形 Type	歯幅 Face Width b	穴径 Bore Diameter da(H8)	ハブ外径 Hub Diameter dh	ハブ長さ Hub Projection lh	全長 Overall Length l	ねじ Set Screw		重量 Weight W(g)
										M	ls	
S75SU 32B + 0606	32	φ24	φ25.5	B1	6	φ6	φ15	9	15	M4	4	30.4
S75SU 36B + 0606	36	φ27	φ28.5	B1	6	φ6	φ18	9	15	M4	4	41.6
S75SU 40B + 0606	40	φ30	φ31.5	B1	6	φ6	φ20	9	15	M4	4	52.2
S75SU 44B + 0606	44	φ33	φ34.5	B1	6	φ6	φ20	9	15	M4	4	59.2
S75SU 45B + 0606	45	φ33.75	φ35.25	B1	6	φ6	φ20	9	15	M4	4	61.1
S75SU 48B + 0606	48	φ36	φ37.5	B1	6	φ6	φ20	9	15	M4	4	67.0
S75SU 56B + 0606	56	φ42	φ43.5	B1	6	φ6	φ20	9	15	M4	4	84.5
S75SU 60B + 0606	60	φ45	φ46.5	B1	6	φ6	φ22	9	15	M4	4	98.9
S75SU 72B + 0606	72	φ54	φ55.5	B1	6	φ6	φ25	9	15	M4	4	139.9
S75SU 80B + 0608	80	φ60	φ61.5	B1	6	φ8	φ25	9	15	M4	4	163.0
S75SU 100B + 0608	100	φ75	φ76.5	B1	6	φ8	φ30	9	15	M4	4	253.9
S75SU 120B + 0608	120	φ90	φ91.5	B1	6	φ8	φ30	9	15	M4	4	346.3

SUS304 の商品にはセットスクリーは付いておりません。
 [+] : Gear with threaded hole / without set screw.

許容伝達動力表 曲げ強さ (W)

Allowable transfer capability table (W) Bending Strength

商品記号 Catalogue Numbers	回転速度 (min ⁻¹) revolution/min						
	10	100	200	400	800	1,200	1,500
S75SU 32B + 0606	2.54	25.39	50.78	101.55	202.94	283.08	336.19
S75SU 36B + 0606	2.97	29.65	59.30	118.60	232.63	322.15	380.76
S75SU 38B + 0606	3.18	31.80	63.61	127.21	247.24	341.17	402.31
S75SU 40B + 0606	3.40	33.97	67.94	135.87	261.67	359.85	423.39
S75SU 44B + 0606	3.83	38.30	76.61	153.22	289.81	395.90	463.82
S75SU 45B + 0606	3.94	39.40	78.80	157.59	296.77	404.75	473.69
S75SU 48B + 0606	4.27	42.69	85.39	170.78	317.37	430.79	502.63
S75SU 56B + 0606	5.16	51.56	103.12	206.23	370.29	496.61	588.14
S75SU 60B + 0606	5.60	56.02	112.05	224.09	395.66	527.64	633.40
S75SU 72B + 0606	6.95	69.52	139.04	272.73	467.65	632.18	765.62
S75SU 80B + 0608	7.86	78.59	157.17	302.69	512.38	704.54	850.72
S75SU 100B + 0608	10.13	101.26	202.52	373.10	619.77	876.96	1,062.41
S75SU 120B + 0608	12.42	124.17	248.33	438.47	742.13	1,047.95	1,267.90

The above numerical values are equivalent to JGMA formulas as reference only.
 動力の換算式は P26 をご参照ください。
 Please refer to the conversion formulas of power on page P26.

目次
CONTENTS

インフォメーション
INFORMATION

ギヤボックス
GEAR BOXES

ノーバッキングギヤ
ANTI BACKLASH SPUR GEARS

歯研削歯車
GROUND SPUR GEARS

平歯車
SPUR GEARS

内歯車
INTERNAL GEARS

歯研削ラック
GROUND RACKS

ラック
RACKS

ハニカム・スクリューギヤ
HELICAL GEARS AND SCREW GEARS

ウォーム・ウォームギヤ
WORMS AND WORM GEARS

かさ歯車
BEVEL GEARS

スプロケット
SPROCKETS

技術データ
REFERENCE DATA

平歯車 SPUR GEARS

モジュール **0.75** 圧力角 20° (並歯)
MODULE 20° PRESSURE ANGLE FULL DEPTH TOOTH

JIS B 1702-1 (ISO) 9 級
System of accuracy : JIS B 1702-1(ISO) class 9

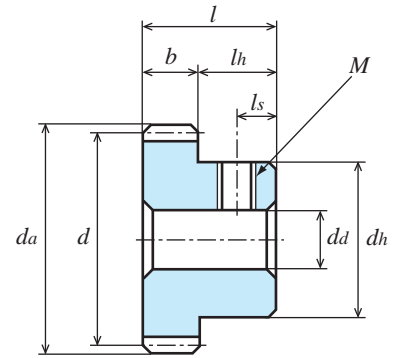
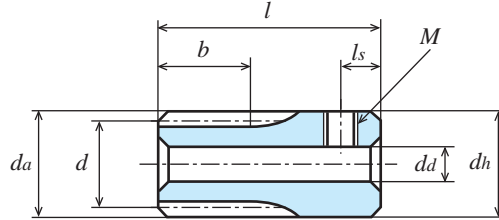
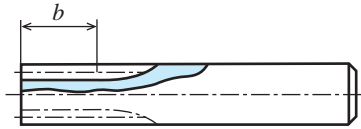

K1形
TYPE K1

B1形
TYPE B1

C3604B 快削黄銅棒 Material : Brass (ISO CuZn39Pb3)

単位 : mm
Dimensions : mm

商品記号 Catalogue Number	歯数 Number of Teeth <i>z</i>	基準円直径 Reference Diameter <i>d</i>	歯先円直径 Tip Diameter <i>da</i>	形 Type	歯幅 Face Width <i>b</i>	穴径 Bore Diameter <i>da(H8)</i>	ハブ外径 Hub Diameter <i>dh</i>	ハブ長さ Hub Projection <i>lh</i>	全長 Overall Length <i>l</i>	ねじ Set Screw		重量 Weight <i>W(g)</i>
										<i>M</i>	<i>ls</i>	
S75B 10K - 0809	10	φ 7.5	φ 9	K1	8	-	φ 9	47	55	-	-	28.4
S75B 12K - 0811	12	φ 9	φ 10.5	K1	8	-	φ 11	47	55	-	-	42.3
S75B 14K + 0805	14	φ 10.5	φ 12	K2	8	φ 5	φ 12	12	20	M3	3	13.9
S75B 15K + 0805	15	φ 11.25	φ 12.75	K2	8	φ 5	φ 12.75	12	20	M3	3	16.3
S75B 16K + 0805	16	φ 12	φ 13.5	K2	8	φ 5	φ 13.5	12	20	M3	3	18.8
S75B 16B + 0305	16	φ 12	φ 13.5	B1	3	φ 5	φ 10	7	10	M3	3.5	5.8
S75B 18K + 0805	18	φ 13.5	φ 15	K2	8	φ 5	φ 15	12	20	M3	3	24.2
S75B 18B + 0305	18	φ 13.5	φ 15	B1	3	φ 5	φ 11	7	10	M3	3.5	7.5
S75B 20K + 0805	20	φ 15	φ 16.5	K2	8	φ 5	φ 16.5	12	20	M3	3	30.2
S75B 20B + 0306	20	φ 15	φ 16.5	B1	3	φ 6	φ 12	7	10	M4	3.5	8.6
S75B 24B + 0306	24	φ 18	φ 19.5	B1	3	φ 6	φ 14	7	10	M4	3.5	11.7
S75B 25B + 0306	25	φ 18.75	φ 20.25	B1	3	φ 6	φ 14	7	10	M4	3.5	12.3
S75B 26B + 0306	26	φ 19.5	φ 21	B1	3	φ 6	φ 14	7	10	M4	3.5	12.9
S75B 28B + 0306	28	φ 21	φ 22.5	B1	3	φ 6	φ 14	7	10	M4	3.5	14.1

【+】にはセットスクリーンが付いております。
【+】: Gear with threaded hole / with set screw.

許容伝達動力表 曲げ強さ (W)

Allowable transfer capability table (W) Bending Strength

商品記号 Catalogue Numbers	回転速度 (min ⁻¹) revolution/min						
	10	100	200	400	800	1,200	1,500
S75B 10K - 0809	0.22	2.18	4.36	8.73	17.46	26.18	32.73
S75B 12K - 0811	0.31	3.06	6.11	12.22	24.45	36.67	45.84
S75B 14K + 0805	0.40	3.98	7.97	15.93	31.87	47.80	59.75
S75B 15K + 0805	0.45	4.46	8.93	17.86	35.72	53.57	66.97
S75B 16K + 0805	0.50	4.95	9.91	19.82	39.64	59.45	74.32
S75B 16B + 0305	0.19	1.86	3.72	7.43	14.86	22.30	27.87
S75B 18K + 0805	0.60	5.96	11.91	23.82	47.65	71.47	88.54
S75B 18B + 0305	0.22	2.23	4.47	8.93	17.87	26.80	33.20
S75B 20K + 0805	0.70	6.99	13.99	27.97	55.94	83.92	102.17
S75B 20B + 0306	0.26	2.62	5.24	10.49	20.98	31.47	38.31
S75B 24B + 0306	0.34	3.42	6.84	13.67	27.35	40.23	48.28
S75B 25B + 0306	0.36	3.62	7.24	14.49	28.98	42.33	50.74
S75B 26B + 0306	0.38	3.83	7.65	15.31	30.62	44.42	53.17
S75B 28B + 0306	0.42	4.24	8.48	16.96	33.92	48.56	57.96

The above numerical values are equivalent to JGMA formulas as reference only.
動力の換算式は P26 をご参照ください。
Please refer to the conversion formulas of power on page P26.

平歯車 SPUR GEARS

モジュール **0.75** 圧力角 20° (並歯)
MODULE 20° PRESSURE ANGLE FULL DEPTH TOOTH

JIS B 1702-1 (ISO) 9 ~ 10 級
System of accuracy : JIS B 1702-1(ISO) class 9-10

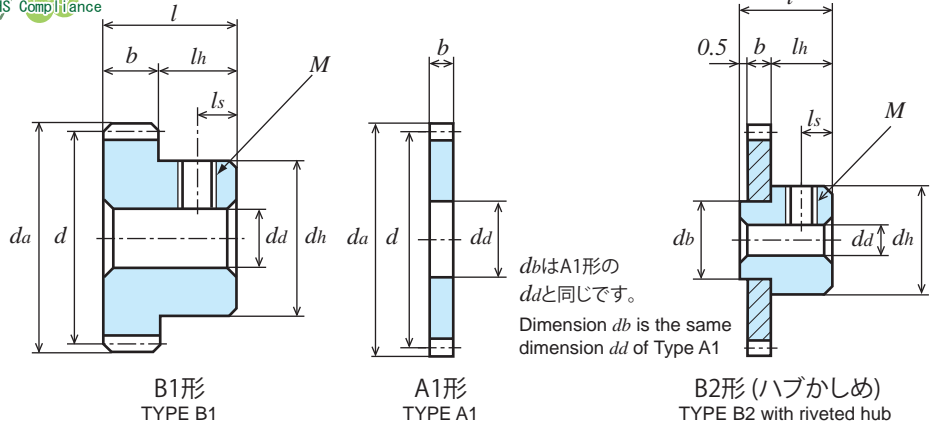

C3713P 快削黄銅板、C3604B 快削黄銅棒 Material : Brass (ISO CuZn38Pb2, CuZn39Pb3)

単位 : mm
Dimensions : mm

商品記号 Catalogue Number	歯数 Number of Teeth z	基準円直径 Reference Diameter d	歯先円直径 Tip Diameter da	形 Type	歯幅 Face Width b	穴径 Bore Diameter da(H8)	ハブ外径 Hub Diameter dh	ハブ長さ Hub Projection lh	全長 Overall Length l	ねじ Set Screw		重量 Weight W(g)
										M	ls	
S75B 30B + 0306	30	φ22.5	φ24	B1	3	φ 6	φ15	7	10	M4	3.5	16.7
S75B 32B + 0306	32	φ24	φ25.5	B1	3	φ 6	φ15	7	10	M4	3.5	18.1
S75B 35B + 0306	35	φ26.25	φ27.75	B1	3	φ 6	φ18	7	10	M4	3.5	24.9
S75B 36B + 0306	36	φ27	φ28.5	B1	3	φ 6	φ18	7	10	M4	3.5	25.7
S75B 40B + 0306	40	φ30	φ31.5	B1	3	φ 6	φ20	7	10	M4	3.5	33.8
S75B 42B + 0306	42	φ31.5	φ33	B1	3	φ 6	φ20	7	10	M4	3.5	35.6
S75B 45B + 0306	45	φ33.75	φ35.25	B1	3	φ 6	φ20	7	10	M4	3.5	38.6
S75B 48B + 0306	48	φ36	φ37.5	B1	3	φ 6	φ20	7	10	M4	3.5	41.7
S75B 50A - 0315	50	φ37.5	φ39	A1	3	φ15	-	-	3	-	-	23.7
S75B 50B + 0306	50	φ37.5	φ39	B2	3	φ 6	φ20	7	10.5	M4	3.5	43.8
S75B 55A - 0315	55	φ41.25	φ42.75	A1	3	φ15	-	-	3	-	-	29.6
S75B 55B + 0306	55	φ41.25	φ42.75	B2	3	φ 6	φ20	7	10.5	M4	3.5	49.7
S75B 56A - 0315	56	φ42	φ43.5	A1	3	φ15	-	-	3	-	-	30.8
S75B 56B + 0306	56	φ42	φ43.5	B2	3	φ 6	φ20	7	10.5	M4	3.5	50.9
S75B 58A - 0315	58	φ43.5	φ45	A1	3	φ15	-	-	3	-	-	33.4
S75B 58B + 0306	58	φ43.5	φ45	B2	3	φ 6	φ20	7	10.5	M4	3.5	53.5
S75B 60A - 0315	60	φ45	φ46.5	A1	3	φ15	-	-	3	-	-	36.1
S75B 60B + 0306	60	φ45	φ46.5	B2	3	φ 6	φ20	7	10.5	M4	3.5	56.2

A1形の穴径はプレスの抜き放しですので (H8) の公差仕上げになっておりません。

Bore tolerance of H8 but does not apply to type A1 gears due to the press item.

【+】にはセットスクリューは付いております。

[+]: Gear with threaded hole / with set screw.

許容伝達動力表 曲げ強さ (W)

Allowable transfer capability table (W) Bending Strength

商品記号 Catalogue Numbers	回転速度 (min ⁻¹) revolution/min						
	10	100	200	400	800	1,200	1,500
S75B 30B + 0306	0.47	4.66	9.31	18.62	37.25	52.61	62.64
S75B 32B + 0306	0.51	5.08	10.16	20.31	40.59	56.62	67.24
S75B 35B + 0306	0.57	5.72	11.43	22.86	45.05	62.50	73.96
S75B 36B + 0306	0.59	5.93	11.86	23.72	46.53	64.43	76.15
S75B 40B + 0306	0.68	6.79	13.59	27.17	52.33	71.97	84.68
S75B 42B + 0306	0.72	7.23	14.46	28.92	55.19	75.64	88.80
S75B 45B + 0306	0.79	7.88	15.76	31.52	59.35	80.95	94.74
S75B 48B + 0306	0.85	8.54	17.08	34.16	63.47	86.16	100.53
S75B 50A - 0315	0.90	8.98	17.96	35.92	66.17	89.54	104.28
S75B 55A - 0315	1.01	10.09	20.18	40.36	72.77	97.73	115.35
S75B 56A - 0315	1.03	10.31	20.62	41.25	74.06	99.32	117.63
S75B 58A - 0315	1.08	10.76	21.52	43.03	76.61	102.45	122.17
S75B 60A - 0315	1.12	11.20	22.41	44.82	79.13	105.53	126.68

The above numerical values are equivalent to JGMA formulas as reference only.

動力の換算式は P26 をご参照ください。

Please refer to the conversion formulas of power on page P26.

RoHS 対応

2006年11月生産開始より欧州 RoHS 指令に対応できる商品を提供しています。

We supplied the KG-products with RoHS compliance of EU to all our valued customers since November 2006

平歯車 SPUR GEARS

モジュール **0.75** 圧力角 20° (並歯)
MODULE 20° PRESSURE ANGLE FULL DEPTH TOOTH

JIS B 1702-1 (ISO) 9~10 級
System of accuracy : JIS B 1702-1(ISO) class 9-10



御注文には必ず “フルネームで商品記号” を明記してください。
Please refer to the catalogue reference while ordering.

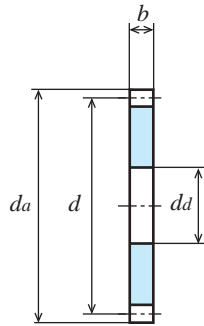

A1形
TYPE A1

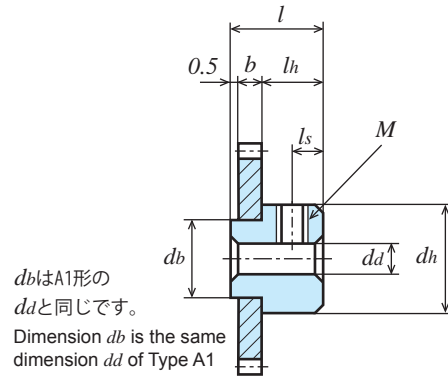

B2形 (ハブかしめ)
TYPE B2 with riveted hub

dbはA1形の
ddと同じです。
Dimension db is the same
dimension dd of Type A1

C3713P 快削黄銅板、C3604B 快削黄銅棒 Material : Brass (ISO CuZn38Pb2, CuZn39Pb3)

単位 : mm
Dimensions : mm

商品記号 Catalogue Number	歯数 Number of Teeth z	基準円直径 Reference Diameter d	歯先円直径 Tip Diameter da	形 Type	歯幅 Face Width b	穴径 Bore Diameter da(H8)	ハブ外径 Hub Diameter dh	ハブ長さ Hub Projection lh	全長 Overall Length l	ねじ Set Screw		重量 Weight W(g)
										M	ls	
S75B 62A - 0315	62	φ46.5	φ48	A1	3	φ15	-	-	3	-	-	38.8
S75B 62B + 0306	62	φ46.5	φ48	B2	3	φ6	φ20	7	10.5	M4	3.5	58.9
S75B 64A - 0315	64	φ48	φ49.5	A1	3	φ15	-	-	3	-	-	41.6
S75B 64B + 0306	64	φ48	φ49.5	B2	3	φ6	φ20	7	10.5	M4	3.5	61.8
S75B 65A - 0315	65	φ48.75	φ50.25	A1	3	φ15	-	-	3	-	-	43.1
S75B 65B + 0306	65	φ48.75	φ50.25	B2	3	φ6	φ20	7	10.5	M4	3.5	63.2
S75B 66A - 0315	66	φ49.5	φ51	A1	3	φ15	-	-	3	-	-	44.6
S75B 66B + 0306	66	φ49.5	φ51	B2	3	φ6	φ20	7	10.5	M4	3.5	64.7
S75B 68A - 0315	68	φ51	φ52.5	A1	3	φ15	-	-	3	-	-	47.6
S75B 68B + 0306	68	φ51	φ52.5	B2	3	φ6	φ20	7	10.5	M4	3.5	67.7
S75B 70A - 0315	70	φ52.5	φ54	A1	3	φ15	-	-	3	-	-	50.7
S75B 70B + 0306	70	φ52.5	φ54	B2	3	φ6	φ20	7	10.5	M4	3.5	70.8
S75B 72A - 0315	72	φ54	φ55.5	A1	3	φ15	-	-	3	-	-	53.9
S75B 72B + 0306	72	φ54	φ55.5	B2	3	φ6	φ20	7	10.5	M4	3.5	74.0
S75B 75A - 0315	75	φ56.25	φ57.75	A1	3	φ15	-	-	3	-	-	58.9
S75B 75B + 0306	75	φ56.25	φ57.75	B2	3	φ6	φ20	7	10.5	M4	3.5	79.0
S75B 80A - 0315	80	φ60	φ61.5	A1	3	φ15	-	-	3	-	-	67.6
S75B 80B + 0306	80	φ60	φ61.5	B2	3	φ6	φ20	7	10.5	M4	3.5	87.7

A1形の穴径はプレスの抜き放しですので (H8) の公差仕上げになっておりません。
Bore tolerance of H8 but does not apply to type A1 gears due to the press item.
【+】にはセットスクリューが付いております。
【+】: Gear with threaded hole / with set screw.

許容伝達動力表 曲げ強さ (W)

Allowable transfer capability table (W) Bending Strength

商品記号 Catalogue Numbers	回転速度 (min ⁻¹) revolution/min						
	10	100	200	400	800	1,200	1,500
S75B 62A - 0315	1.17	11.65	23.30	46.61	81.62	108.54	131.16
S75B 64A - 0315	1.21	12.10	24.20	48.37	84.07	111.64	135.62
S75B 65A - 0315	1.23	12.33	24.65	49.15	85.28	113.50	137.83
S75B 66A - 0315	1.26	12.55	25.10	49.93	86.48	115.37	140.04
S75B 68A - 0315	1.30	13.00	26.00	51.48	88.86	119.08	144.43
S75B 70A - 0315	1.35	13.45	26.90	53.02	91.21	122.77	148.79
S75B 72A - 0315	1.39	13.90	27.81	54.55	93.53	126.44	153.12
S75B 75A - 0315	1.46	14.58	29.17	56.81	96.94	131.90	159.56
S75B 80A - 0315	1.57	15.72	31.43	60.54	102.48	140.91	170.15

The above numerical values are equivalent to JGMA formulas as reference only.
動力の換算式は P26 をご参照ください。
Please refer to the conversion formulas of power on page P26.

RoHS 対応

2006年11月生産開始日より欧州 RoHS 指令に対応できる商品を提供しています。
We supplied the KG-products with RoHS compliance of EU to all our valued customers since November 2006

平歯車 SPUR GEARS

モジュール **0.75** 圧力角 20° (並歯)
MODULE 20° PRESSURE ANGLE FULL DEPTH TOOTH

JIS B 1702-1 (ISO) 9~10 級
System of accuracy : JIS B 1702-1(ISO) class 9-10



御注文には必ず“フルネームで商品記号”を明記してください。
Please refer to the catalogue reference while ordering.

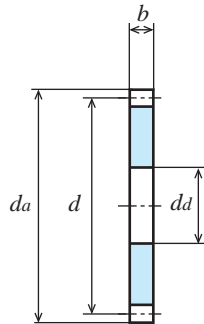

A1形
TYPE A1

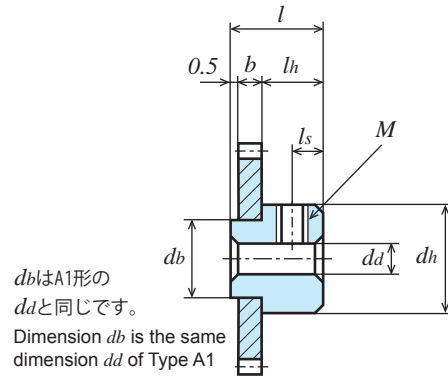

B2形 (ハブかしめ)
TYPE B2 with riveted hub

dbはA1形の
ddと同じです。
Dimension db is the same
dimension dd of Type A1

C3713P 快削黄銅板、C3604B 快削黄銅棒 Material : Brass (ISO CuZn38Pb2, CuZn39Pb3)

単位 : mm
Dimensions : mm

商品記号 Catalogue Number	歯数 Number of Teeth z	基準円直径 Reference Diameter d	歯先円直径 Tip Diameter da	形 Type	歯幅 Face Width b	穴径 Bore Diameter da(H8)	ハブ外径 Hub Diameter dh	ハブ長さ Hub Projection lh	全長 Overall Length l	ねじ Set Screw		重量 Weight W(g)
										M	ls	
S75B 85A - 0315	85	φ63.75	φ65.25	A1	3	φ15	-	-	3	-	-	76.9
S75B 85B + 0306	85	φ63.75	φ65.25	B2	3	φ6	φ20	7	10.5	M4	3.5	97.0
S75B 90A - 0315	90	φ67.5	φ69	A1	3	φ15	-	-	3	-	-	86.7
S75B 90B + 0306	90	φ67.5	φ69	B2	3	φ6	φ20	7	10.5	M4	3.5	106.9
S75B 95A - 0315	95	φ71.25	φ72.75	A1	3	φ15	-	-	3	-	-	97.2
S75B 95B + 0306	95	φ71.25	φ72.75	B2	3	φ6	φ20	7	10.5	M4	3.5	117.3
S75B 100A - 0315	100	φ75	φ76.5	A1	3	φ15	-	-	3	-	-	108.1
S75B 100B + 0306	100	φ75	φ76.5	B2	3	φ6	φ20	7	10.5	M4	3.5	128.3
S75B 105A - 0315	105	φ78.75	φ80.25	A1	3	φ15	-	-	3	-	-	119.7
S75B 105B + 0306	105	φ78.75	φ80.25	B2	3	φ6	φ20	7	10.5	M4	3.5	139.8
S75B 110A - 0315	110	φ82.5	φ84	A1	3	φ15	-	-	3	-	-	131.8
S75B 110B + 0306	110	φ82.5	φ84	B2	3	φ6	φ20	7	10.5	M4	3.5	151.9
S75B 115A - 0315	115	φ86.25	φ87.75	A1	3	φ15	-	-	3	-	-	144.5
S75B 115B + 0306	115	φ86.25	φ87.75	B2	3	φ6	φ20	7	10.5	M4	3.5	164.6
S75B 120A - 0315	120	φ90	φ91.5	A1	3	φ15	-	-	3	-	-	157.7
S75B 120B + 0306	120	φ90	φ91.5	B2	3	φ6	φ20	7	10.5	M4	3.5	177.8

A1形の穴径はプレスの抜き出しですので (H8) の公差仕上げになっておりません。

Bore tolerance of H8 but does not apply to type A1 gears due to the press item.

【+】にはセットスクリーンが付いております。

【+】: Gear with threaded hole / with set screw.

許容伝達動力表 曲げ強さ (W)

Allowable transfer capability table (W) Bending Strength

商品記号 Catalogue Numbers	回転速度 (min ⁻¹) revolution/min						
	10	100	200	400	800	1,200	1,500
S75B 85A - 0315	1.68	16.84	33.67	64.12	107.70	149.62	180.35
S75B 90A - 0315	1.80	17.97	35.94	67.69	112.84	158.34	191.18
S75B 95A - 0315	1.91	19.11	38.22	71.19	117.82	166.93	201.90
S75B 100A - 0315	2.03	20.25	40.50	74.62	123.95	175.39	212.48
S75B 105A - 0315	2.14	21.39	42.79	77.98	130.17	183.73	222.94
S75B 110A - 0315	2.25	22.54	45.08	81.28	136.32	192.36	233.28
S75B 115A - 0315	2.37	23.69	47.37	84.52	142.40	201.01	243.49
S75B 120A - 0315	2.48	24.83	49.67	87.69	148.43	209.59	253.58

The above numerical values are equivalent to JGMA formulas as reference only.

動力の換算式は P26 をご参照ください。

Please refer to the conversion formulas of power on page P26.

RoHS 対応

2006年11月生産開始より欧州 RoHS 指令に対応できる商品を提供しています。
We supplied the KG-products with RoHS compliance of EU to all our valued customers since November 2006

- 目次 CONTENTS
- インフォメーション INFORMATION
- ギヤボックス GEAR BOXES
- ノーバッキングギヤ NO BACKLASH SPUR GEARS
- 歯研平歯車 GROUND SPUR GEARS
- 平歯車 SPUR GEARS
- 内歯車 INTERNAL GEARS
- 歯研ラック GROUND RACKS
- ラック RACKS
- ハブ・スクリューギヤ HELICAL GEARS AND SCREW GEARS
- ワーム・ワームギヤ WORMS AND WORM GEARS
- かさ歯車 BEVEL GEARS
- スプロケット SPROCKETS
- 技術資料 REFERENCE DATA

平歯車 SPUR GEARS

モジュール **0.75** 圧力角 20° (並歯)
MODULE 20° PRESSURE ANGLE FULL DEPTH TOOTH

JIS B 1702-1 (ISO) 8~9 級
System of accuracy : JIS B 1702-1(ISO) class 8-9

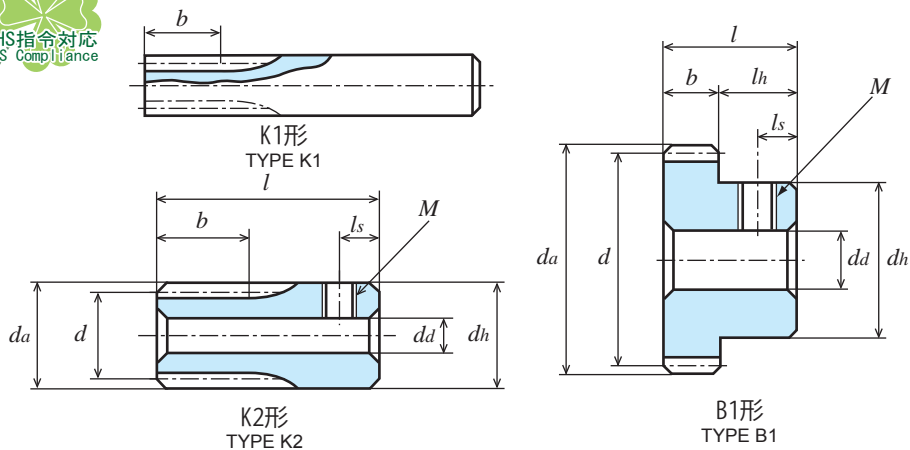

S45C 機械構造用炭素鋼 (JIS G 4051) Material : Carbon Steel (ISO C45)

単位 : mm
Dimensions : mm

商品記号 Catalogue Number	歯数 Number of Teeth z	基準円直径 Reference Diameter d	歯先円直径 Tip Diameter da	形 Type	歯幅 Face Width b	穴径 Bore Diameter da(H7)	ハブ外径 Hub Diameter dh	ハブ長さ Hub Projection lh	全長 Overall Length l	ねじ Set Screw		重量 Weight W(g)
										M	ls	
S75S 10K - 0809	10	φ 7.5	φ 9	K1	8	-	φ 9	47	55	-	-	26.3
S75S 12K - 0811	12	φ 9	φ 10.5	K1	8	-	φ 11	47	55	-	-	39.1
S75S 14K + 0805	14	φ 10.5	φ 12	K2	8	φ 5	φ 12	12	20	M3	3	12.9
S75S 15K + 0805	15	φ 11.25	φ 12.75	K2	8	φ 5	φ 12.75	12	20	M3	3	15.0
S75S 16B + 0805	16	φ 12	φ 13.5	B1	8	φ 5	φ 10	7	15	M4	3.5	8.9
S75S 18B + 0805	18	φ 13.5	φ 15	B1	8	φ 5	φ 11	7	15	M4	3.5	11.7
S75S 20B + 0806	20	φ 15	φ 16.5	B1	8	φ 6	φ 12	7	15	M4	3.5	13.8
S75S 24B + 0806	24	φ 18	φ 19.5	B1	8	φ 6	φ 14	7	15	M4	3.5	20.8
S75S 25B + 0806	25	φ 18.75	φ 20.25	B1	8	φ 6	φ 14	7	15	M4	3.5	22.2
S75S 28B + 0806	28	φ 21	φ 22.5	B1	8	φ 6	φ 14	7	15	M4	3.5	26.6
S75S 30B + 0806	30	φ 22.5	φ 24	B1	8	φ 6	φ 15	7	15	M4	3.5	31.0
S75S 32B + 0606	32	φ 24	φ 25.5	B1	6	φ 6	φ 15	9	15	M4	4	30.1
S75S 35B + 0606	35	φ 26.25	φ 27.75	B1	6	φ 6	φ 18	9	15	M4	4	39.7
S75S 36B + 0606	36	φ 27	φ 28.5	B1	6	φ 6	φ 18	9	15	M4	4	41.2

【+】にはセットスクリューは付いております。
【+】: Gear with threaded hole / with set screw.

許容伝達動力表 曲げ強さ (W)

Allowable transfer capability table (W) Bending Strength

商品記号 Catalogue Numbers	回転速度 (min ⁻¹) revolution/min						
	10	100	200	400	800	1,200	1,500
S75S 10K - 0809	1.10	11.07	22.14	44.29	88.59	132.88	166.10
S75S 12K - 0811	1.53	15.28	30.56	61.12	122.24	183.36	229.20
S75S 14K + 0805	1.99	19.92	39.84	79.67	159.35	239.02	298.77
S75S 15K + 0805	2.23	22.32	44.64	89.29	178.58	267.86	334.83
S75S 16B + 0805	2.48	24.77	49.54	99.09	198.18	297.27	371.59
S75S 18B + 0805	2.98	29.78	59.56	119.12	238.23	357.35	442.68
S75S 20B + 0806	3.50	34.97	69.93	139.86	279.72	419.58	510.83
S75S 24B + 0806	4.56	45.58	91.17	182.33	364.66	536.45	643.79
S75S 25B + 0806	4.83	48.30	96.59	193.18	386.36	564.46	676.47
S75S 28B + 0806	5.65	56.54	113.08	226.16	452.32	647.45	772.83
S75S 30B + 0806	6.21	62.08	124.17	248.66	496.66	701.46	835.14
S75S 32B + 0606	5.08	50.78	101.55	203.10	405.88	566.16	672.37
S75S 35B + 0606	5.72	57.16	114.32	228.63	450.54	625.02	739.59
S75S 36B + 0606	5.93	59.30	118.60	237.20	465.26	644.30	761.51

The above numerical values are equivalent to JGMA formulas as reference only.
動力の換算式は P26 をご参照ください。
Please refer to the conversion formulas of power on page P26.

RoHS 対応

2006年11月生産開始分より欧州 RoHS 指令に対応できる商品を提供しています。
We supplied the KG-products with RoHS compliance of EU to all our valued customers since November 2006

平歯車 SPUR GEARS

モジュール **0.75** 圧力角 20° (並歯)
MODULE 20° PRESSURE ANGLE FULL DEPTH TOOTH

JIS B 1702-1 (ISO) 8 級
System of accuracy : JIS B 1702-1(ISO) class 8



御注文には必ず“フルネームで商品記号”を明記してください。
Please refer to the catalogue reference while ordering.

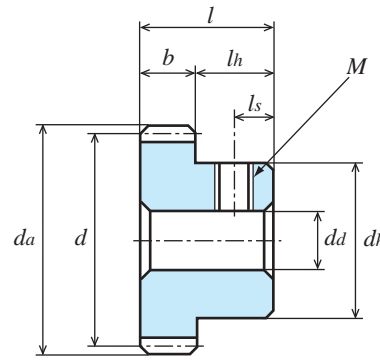

B1形
TYPE B1

S45C 機械構造用炭素鋼 (JIS G 4051) Material : Carbon Steel (ISO C45)

単位 : mm
Dimensions : mm

商品記号 Catalogue Number	歯数 Number of Teeth z	基準円直径 Reference Diameter d	歯先円直径 Tip Diameter da	形 Type	歯幅 Face Width b	穴径 Bore Diameter da(H7)	ハブ外径 Hub Diameter dh	ハブ長さ Hub Projection lh	全長 Overall Length l	ねじ Set Screw		重量 Weight W(g)
										M	ls	
S75S 40B + 0606	40	φ30	φ31.5	B1	6	φ6	φ20	9	15	M4	4	51.7
S75S 45B + 0606	45	φ33.75	φ35.25	B1	6	φ6	φ20	9	15	M4	4	60.5
S75S 48B + 0606	48	φ36	φ37.5	B1	6	φ6	φ20	9	15	M4	4	66.3
S75S 50B + 0606	50	φ37.5	φ39	B1	6	φ6	φ20	9	15	M4	4	70.4
S75S 56B + 0606	56	φ42	φ43.5	B1	6	φ6	φ20	9	15	M4	4	83.6
S75S 60B + 0606	60	φ45	φ46.5	B1	6	φ6	φ22	9	15	M4	4	97.9
S75S 64B + 0606	64	φ48	φ49.5	B1	6	φ6	φ22	9	15	M4	4	108.2
S75S 70B + 0606	70	φ52.5	φ54	B1	6	φ6	φ22	9	15	M4	4	124.9
S75S 72B + 0606	72	φ54	φ55.5	B1	6	φ6	φ25	9	15	M4	4	138.5
S75S 80B + 0608	80	φ60	φ61.5	B1	6	φ8	φ25	9	15	M4	4	161.3
S75S 90B + 0608	90	φ67.5	φ69	B1	6	φ8	φ30	9	15	M4	4	211.8
S75S 100B + 0608	100	φ75	φ76.5	B1	6	φ8	φ30	9	15	M4	4	251.3
S75S 120B + 0608	120	φ90	φ91.5	B1	6	φ8	φ30	9	15	M4	4	342.9

[+] にはセットスクリューは付いております。
[+]: Gear with threaded hole / with set screw.

許容伝達動力表 曲げ強さ (W)

Allowable transfer capability table (W) Bending Strength

商品記号 Catalogue Numbers	回転速度 (min ⁻¹) revolution/min						
	10	100	200	400	800	1,200	1,500
S75S 40B + 0606	6.79	67.94	135.87	271.74	523.34	719.70	846.78
S75S 45B + 0606	7.88	78.80	157.59	315.19	593.54	809.50	947.38
S75S 48B + 0606	8.54	85.39	170.78	341.55	634.74	861.57	1,005.26
S75S 50B + 0606	8.98	89.80	179.60	359.20	661.75	895.45	1,042.75
S75S 56B + 0606	10.31	103.12	206.23	412.46	740.57	993.21	1,176.28
S75S 60B + 0606	11.20	112.05	224.09	448.18	791.32	1,055.28	1,266.80
S75S 64B + 0606	12.10	121.01	242.03	483.67	840.68	1,116.37	1,356.16
S75S 70B + 0606	13.45	134.52	269.05	530.18	912.13	1,227.65	1,487.91
S75S 72B + 0606	13.90	139.04	278.08	545.45	935.29	1,264.36	1,531.23
S75S 80B + 0608	15.72	157.17	314.34	605.38	1,024.75	1,409.08	1,701.45
S75S 90B + 0608	17.97	179.72	359.44	676.87	1,128.44	1,583.37	1,911.84
S75S 100B + 0608	20.25	202.52	405.04	746.20	1,239.53	1,753.91	2,124.81
S75S 120B + 0608	24.83	248.33	496.67	876.93	1,484.26	2,095.89	2,535.81

The above numerical values are equivalent to JGMA formulas as reference only.
動力の換算式は P26 をご参照ください。
Please refer to the conversion formulas of power on page P26.

目次
CONTENTS

インフォメーション
INFORMATION

ギヤボックス
GEAR BOXES

ノーバッキングギヤ
ANTI BACKLASH SPUR GEARS

歯研平歯車
GROUND SPUR GEARS

平歯車
SPUR GEARS

内歯車
INTERNAL GEARS

歯研ラック
GROUND RACKS

ラック
RACKS

へリカル・スクリューギヤ
HELICAL GEARS AND SCREW GEARS

ウォーム・ウォームギヤ
WORMS AND WORM GEARS

かさ歯車
BEVEL GEARS

スプロケット
SPROCKETS

技術データ
REFERENCE DATA

平歯車 SPUR GEARS

モジュール **0.8** 圧力角 20° (並歯)
MODULE 20° PRESSURE ANGLE FULL DEPTH TOOTH

JIS B 1702-1 (ISO) 8級 (高周波焼入品: 9級)
System of accuracy: JIS B 1702-1(ISO) class 8
(Induction hardened products: class 9)

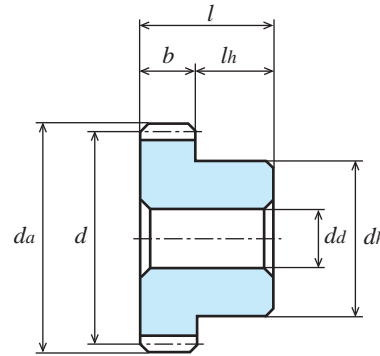

B1形
TYPE B1

S45C 機械構造用炭素鋼 (JIS G 4051) Material: Carbon Steel (ISO C45)

単位: mm
Dimensions: mm

商品記号 Catalogue Number	歯数 Number of Teeth <i>z</i>	基準円直径 Reference Diameter <i>d</i>	歯先円直径 Tip Diameter <i>da</i>	形 Type	歯幅 Face Width <i>b</i>	穴径 Bore Diameter <i>da(H8)</i>	ハブ外径 Hub Diameter <i>dh</i>	ハブ長さ Hub Projection <i>lh</i>	全長 Overall Length <i>l</i>	重量 Weight <i>W(g)</i>
● S80S 25BF - 0805	25	φ20	φ21.6	B1	8	φ5	φ16	10	18	32.5
● S80S 25B - 0805H	25	φ20	φ21.6	B1	8	φ5(H※)	φ16	10	18	32.5
● S80S 30BF - 0805	30	φ24	φ25.6	B1	8	φ5	φ20	10	18	50.1
● S80S 30B - 0805H	30	φ24	φ25.6	B1	8	φ5(H※)	φ20	10	18	50.1
● S80S 40BF - 0806	40	φ32	φ33.6	B1	8	φ6	φ25	10	18	84.7
● S80S 40B - 0806H	40	φ32	φ33.6	B1	8	φ6(H※)	φ25	10	18	84.7
● S80S 50BF - 0806	50	φ40	φ41.6	B1	8	φ6	φ28	10	18	122.9
● S80S 50B - 0806H	50	φ40	φ41.6	B1	8	φ6(H※)	φ28	10	18	122.9

● の商品は新商品です。
Products with ● marks are new item.

カタログ記号の末尾に【H】を付した商品は歯部高周波焼入済です。Gear tooth surface completed with induction hardening, Hardness HRC47 to 53.
※
歯部高周波焼入後の穴修正は行っていません。Bore correcting after induction hardening is not completed.
追加加工の際は、追加加工時の注意をご参照ください。Please refer to Precaution for additional process when additional process.

許容伝達動力表 曲げ強さ (W)

Allowable transfer capability table (W) Bending Strength

商品記号 Catalogue Numbers	回転速度 (min ⁻¹) revolution/min						
	10	100	200	400	800	1,200	1,500
S80S 25BF - 0805	5.52	55.18	110.37	220.74	441.48	637.09	761.80
S80S 25B - 0805H	5.85	58.46	116.91	233.83	467.65	677.83	813.51
S80S 30BF - 0805	7.07	70.68	141.37	282.73	565.46	848.19	936.16
S80S 30B - 0805H	7.50	74.96	149.93	299.85	599.22	841.29	1,003.36
S80S 40BF - 0806	10.28	102.83	205.66	411.32	782.43	1,071.87	1,256.58
S80S 40B - 0806H	10.90	109.02	218.04	436.08	833.49	1,149.74	1,355.60
S80S 50BF - 0806	13.57	135.71	271.42	542.84	985.16	1,326.95	1,556.59
S80S 50B - 0806H	14.38	143.82	287.65	575.29	1,053.52	1,430.70	1,686.59

The above references are JGMA standard.

動力の換算式は P26 をご参照ください。Please refer to the conversion formulas of power on page P26.

許容伝達動力表 歯面強さ (W)

Allowable transfer capability table (W) Surface Durability

	回転速度 (min ⁻¹) revolution/min						
	10	100	200	400	800	1,200	1,500
	0.26	2.62	5.24	10.47	20.94	31.41	37.70
	1.16	12.85	26.48	54.61	112.59	166.11	201.30
	0.38	3.77	7.54	15.50	31.00	43.98	51.83
	1.70	18.82	38.80	80.02	164.78	235.47	283.64
	0.69	7.02	14.03	28.06	54.45	75.40	89.53
	3.11	34.39	70.89	146.17	287.99	404.36	481.47
	1.12	11.20	22.41	45.24	83.77	115.61	138.22
	4.96	54.88	113.15	233.26	440.39	608.71	724.70

平歯車 SPUR GEARS

モジュール **0.8** 圧力角 20° (並歯)
MODULE 20° PRESSURE ANGLE FULL DEPTH TOOTH

JIS B 1702-1 (ISO) 8級 (高周波焼入品: 9級)
System of accuracy: JIS B 1702-1(ISO) class 8
(Induction hardened products: class 9)



御注文には必ず“フルネームで商品記号”を明記してください。
Please refer to the catalogue reference while ordering.

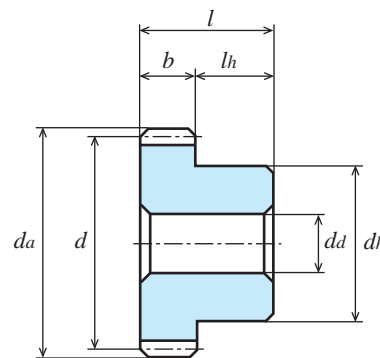

B1形
TYPE B1

S45C 機械構造用炭素鋼 (JIS G 4051) Material: Carbon Steel (ISO C45)

単位: mm
Dimensions: mm

商品記号 Catalogue Number	歯数 Number of Teeth <i>z</i>	基準円直径 Reference Diameter <i>d</i>	歯先円直径 Tip Diameter <i>da</i>	形 Type	歯幅 Face Width <i>b</i>	穴径 Bore Diameter <i>da</i> (H7)	ハブ外径 Hub Diameter <i>dh</i>	ハブ長さ Hub Projection <i>lh</i>	全長 Overall Length <i>l</i>	重量 Weight <i>W</i> (g)
● S80S 60BF - 0806	60	φ48	φ49.6	B1	8	φ 6(H8)	φ34	10	18	180.5
● S80S 60B - 0806H	60	φ48	φ49.6	B1	8	φ 6(H※)	φ34	10	18	180.5
● S80S 70BF - 0808	70	φ56	φ57.6	B1	8	φ 8	φ40	10	18	245.7
● S80S 70B - 0808H	70	φ56	φ57.6	B1	8	φ 8(H※)	φ40	10	18	245.7
● S80S 80BF - 0808	80	φ64	φ65.6	B1	8	φ 8	φ45	10	18	319.2
● S80S 80B - 0808H	80	φ64	φ65.6	B1	8	φ 8(H※)	φ45	10	18	319.2
● S80S 90BF - 0808	90	φ72	φ73.6	B1	8	φ 8	φ50	10	18	402.1
● S80S 90B - 0808H	90	φ72	φ73.6	B1	8	φ 8(H※)	φ50	10	18	402.1
● S80S 100BF - 0810	100	φ80	φ81.6	B1	8	φ10	φ60	10	18	525.8
● S80S 100B - 0810H	100	φ80	φ81.6	B1	8	φ10(H※)	φ60	10	18	525.8
● S80S 120BF - 0810	120	φ96	φ97.6	B1	8	φ10	φ70	10	18	744.7
● S80S 120B - 0810H	120	φ96	φ97.6	B1	8	φ10(H※)	φ70	10	18	744.7

●の商品は新商品です。
Products with ● marks are new item.

カタログ記号の末尾に【H】を付した商品は歯部高周波焼入済です。Gear tooth surface completed with induction hardening, Hardness HRC47 to 53.
※

歯部高周波焼入後の穴修正は行っていません。Bore correcting after induction hardening is not completed.
追加加工の際は、追加加工時の注意をご参照ください。Please refer to Precaution for additional process when additional process.

許容伝達動力表 曲げ強さ (W)

Allowable transfer capability table (W) Bending Strength

商品記号 Catalogue Numbers	回転速度 (min ⁻¹) revolution/min						
	10	100	200	400	800	1,200	1,500
S80S60BF - 0806	16.90	169.01	338.02	675.62	1,174.49	1,559.42	1,894.30
S80S60B - 0806H	17.92	179.21	358.42	716.35	1,260.04	1,688.73	2,055.57
S80S70BF - 0808	20.27	202.73	405.46	790.39	1,349.57	1,834.61	2,219.44
S80S70B - 0808H	21.50	214.96	429.91	840.04	1,453.05	1,989.95	2,412.94
S80S80BF - 0808	23.68	236.76	473.52	900.97	1,512.09	2,102.26	2,535.16
S80S80B - 0808H	25.10	250.96	501.93	959.31	1,633.36	2,282.96	2,760.51
S80S90BF - 0808	27.05	270.48	540.96	1,005.69	1,663.72	2,358.61	2,854.02
S80S90B - 0808H	28.68	286.79	573.59	1,072.86	1,801.68	2,564.52	3,154.83
S80S100BF - 0810	30.47	304.72	609.44	1,106.63	1,850.53	2,609.92	3,168.16
S80S100B - 0810H	32.30	323.03	646.07	1,183.16	2,005.39	2,842.69	3,553.37
S80S120BF - 0810	37.33	373.31	746.20	1,296.79	2,210.75	3,123.87	3,771.32
S80S120B - 0810H	39.58	395.81	791.06	1,391.49	2,400.42	3,483.25	4,354.06

The above references are JGMA standard.

動力の換算式は P26 をご参照ください。Please refer to the conversion formulas of power on page P26.

許容伝達動力表 歯面強さ (W)

Allowable transfer capability table (W) Surface Durability

商品記号 Catalogue Numbers	回転速度 (min ⁻¹) revolution/min						
	10	100	200	400	800	1,200	1,500
S80S60BF - 0806	1.63	16.44	32.88	66.60	118.12	162.10	201.05
S80S60B - 0806H	7.27	80.41	165.79	341.55	619.33	844.91	1,038.64
S80S70BF - 0808	2.25	22.72	45.66	90.06	158.33	222.42	274.88
S80S70B - 0808H	10.04	111.06	228.98	461.22	822.39	1,146.49	1,403.86
S80S80BF - 0808	2.98	30.05	60.53	116.86	203.57	291.53	362.84
S80S80B - 0808H	13.28	146.92	302.91	596.81	1,047.41	1,490.29	1,819.73
S80S90BF - 0808	3.83	38.54	77.70	147.02	252.99	371.95	464.94
S80S90B - 0808H	17.00	188.04	387.67	747.52	1,294.06	1,874.86	2,329.10
S80S100BF - 0810	4.78	48.17	97.18	180.11	314.15	463.68	581.17
S80S100B - 0810H	21.20	234.49	483.43	912.62	1,594.60	2,300.94	2,904.37
S80S120BF - 0810	7.02	70.79	143.04	254.25	454.88	682.33	851.34
S80S120B - 0810H	31.06	343.56	707.81	1,283.48	2,282.36	3,371.30	4,255.45

目次
CONTENTS

インフォメーション
INFORMATION

ギヤボックス
GEAR BOXES

ノーバッキングバックラッシュギヤ
ANTI BACKLASH SPUR GEARS

齒研削歯車
GROUND SPUR GEARS

平歯車
SPUR GEARS

内歯車
INTERNAL GEARS

齒研削ラック
GROUND RACKS

ラック
RACKS

ハニカム・スクリューギヤ
HELIICAL GEARS AND SCREW GEARS

ウォーム・ウォームホイール
WORMS AND WORM WHEELS

かさ歯車
BEVEL GEARS

スプロケット
SPROCKETS

技術資料
REFERENCE DATA

平歯車

SPUR GEARS

モジュール **0.8** 圧力角 20° (並歯)
 MODULE 20° PRESSURE ANGLE FULL DEPTH TOOTH

JIS B 1702-1 (ISO) 9~10 級
 System of accuracy : JIS B 1702-1(ISO) class 9-10

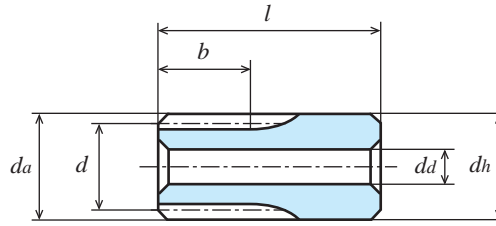

K2形
TYPE K2

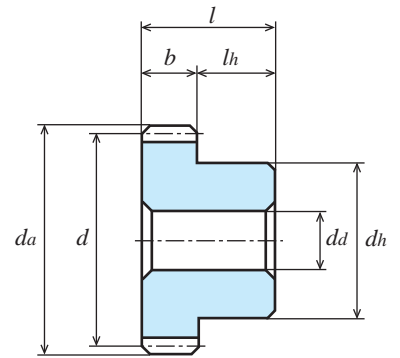

B1形
TYPE B1

ポリアセタール (白色)
 Material : Poly Acetal (White)

単位 : mm
 Dimensions : mm

商品記号 Catalogue Number	歯数 Number of Teeth z	基準円直径 Reference Diameter d	歯先円直径 Tip Diameter d_a	形 Type	歯幅 Face Width b	穴径 Bore Diameter d_a	ハブ外径 Hub Diameter d_h	ハブ長さ Hub Projection l_h	全長 Overall Length l	重量 Weight $W(g)$
S80D 14K - 0704	14	φ11.2	φ12.8	K2	7	φ4	φ12.8	13	20	3.0
S80D 15K - 0704	15	φ12	φ13.6	K2	7	φ4	φ13.6	13	20	3.4
S80D 16B - 0504	16	φ12.8	φ14.4	B1	5	φ4	φ10	9	14	1.7
S80D 18B - 0504	18	φ14.4	φ16	B1	5	φ4	φ10	9	14	1.9
S80D 20B - 0504	20	φ16	φ17.6	B1	5	φ4	φ10	9	14	2.2
S80D 22B - 0505	22	φ17.6	φ19.2	B1	5	φ5	φ12.5	9	14	2.9
S80D 24B - 0505	24	φ19.2	φ20.8	B1	5	φ5	φ12.5	9	14	3.2
S80D 25B - 0505	25	φ20	φ21.6	B1	5	φ5	φ12.5	9	14	3.4
S80D 28B - 0505	28	φ22.4	φ24	B1	5	φ5	φ12.5	9	14	4.0
S80D 30B - 0505	30	φ24	φ25.6	B1	5	φ5	φ12.5	9	14	4.4
S80D 32B - 0505	32	φ25.6	φ27.2	B1	5	φ5	φ12.5	9	14	4.8
S80D 36B - 0506	36	φ28.8	φ30.4	B1	5	φ6	φ14	9	14	6.0
S80D 40B - 0506	40	φ32	φ33.6	B1	5	φ6	φ14	9	14	7.1
S80D 45B - 0506	45	φ36	φ37.6	B1	5	φ6	φ14	9	14	8.6

波形スプリングピン付き、歯数 14 ~ 45 呼び径は φ1 です。(ステンレス)
 Gear with Corrugated spring (SUS) as dimension of φ1.0

目次
CONTENTS

インフォメーション
INFORMATION

ギヤボックス
GEAR BOXES

ノーバックラッシュギヤ
ANTI BACKLASH SPUR GEARS

歯研平歯車
GROUND SPUR GEARS

平歯車
SPUR GEARS

内歯車
INTERNAL GEARS

歯研ラック
GROUND RACKS

ラック
RACKS

へリカルスクリューギヤ
HELICAL GEARS AND SCREW GEARS

ウォーム
WORMS AND WORM WHEELS

かさ歯車
BEVEL GEARS

スプロケット
SPURKETS

技術資料
REFERENCE DATA

平歯車 SPUR GEARS

モジュール **0.8** 圧力角 20° (並歯)
MODULE 20° PRESSURE ANGLE FULL DEPTH TOOTH

JIS B 1702-1 (ISO) 9~10 級
System of accuracy : JIS B 1702-1(ISO) class 9-10



御注文には必ず“フルネームで商品記号”を明記してください。
Please refer to the catalogue reference while ordering.

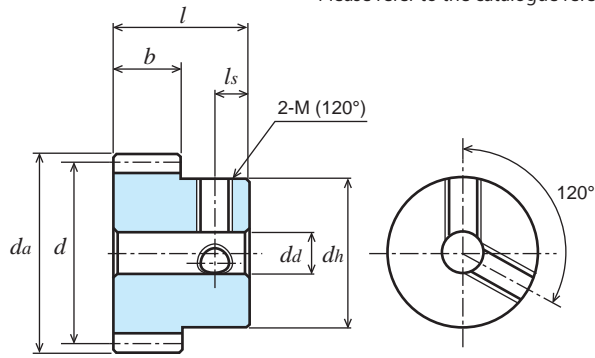

B1形
TYPE B1

ポリアセタール (白色)
Material : Poly Acetal (White)

単位 : mm
Dimensions : mm

商品記号 Catalogue Number	歯数 Number of Teeth z	基準円直径 Reference Diameter d	歯先円直径 Tip Diameter da	形 Type	歯幅 Face Width b	穴径 Bore Diameter da	ハブ外径 Hub Diameter dh	ハブ長さ Hub Projection lh	全長 Overall Length l	ねじ Set Screw		重量 Weight W(g)
										2-M(120°)	ls	
S80D 14K * 0703	14	φ11.2	φ12.8	K2	7	φ3	φ12.8	13	20	2-M3	3	3.1
S80D 15K * 0703	15	φ12	φ13.6	K2	7	φ3	φ13.6	13	20	2-M3	3	3.5
S80D 16B * 0503	16	φ12.8	φ14.4	B1	5	φ3	φ10	7	12	2-M3	4	1.5
S80D 18B * 0503	18	φ14.4	φ16	B1	5	φ3	φ12	7	12	2-M3	4	2.1
S80D 20B * 0503	20	φ16	φ17.6	B1	5	φ3	φ12	7	12	2-M3	4	2.4
S80D 22B * 0503	22	φ17.6	φ19.2	B1	5	φ3	φ15	7	12	2-M3	4	3.3
S80D 24B * 0503	24	φ19.2	φ20.8	B1	5	φ3	φ16	7	12	2-M3	4	3.9
S80D 25B * 0503	25	φ20	φ21.6	B1	5	φ3	φ16	7	12	2-M3	4	4.0
S80D 28B * 0503	28	φ22.4	φ24	B1	5	φ3	φ20	7	12	2-M3	4	5.7
S80D 30B * 0503	30	φ24	φ25.6	B1	5	φ3	φ20	7	12	2-M3	4	6.1
S80D 32B * 0503	32	φ25.6	φ27.2	B1	5	φ3	φ20	7	12	2-M3	4	6.6
S80D 36B * 0504	36	φ28.8	φ30.4	B1	5	φ4	φ22	7	12	2-M4	4	8.1
S80D 40B * 0504	40	φ32	φ33.6	B1	5	φ4	φ22	7	12	2-M4	4	9.2
S80D 45B * 0504	45	φ36	φ37.6	B1	5	φ4	φ22	7	12	2-M4	4	10.7

【*】(アスタ)にはセットスクリーが2個付いております。
[*]: Gear with two threaded holes / with two set screws.

許容伝達動力表 曲げ強さ (W)

Allowable transfer capability table (W) Bending Strength

商品記号 Catalogue Numbers	回転速度 (min ⁻¹) revolution/min						
	10	100	200	400	800	1,200	1,500
S80D 14K * 0703	0.50	5.02	10.03	20.05	40.04	59.98	74.90
S80D 15K * 0703	0.54	5.37	10.75	21.48	42.89	64.24	80.22
S80D 16B * 0503	0.41	4.10	8.19	16.36	32.67	48.93	61.10
S80D 18B * 0503	0.46	4.61	9.21	18.40	36.74	55.02	68.68
S80D 20B * 0503	0.51	5.12	10.23	20.44	40.81	61.10	76.26
S80D 22B * 0503	0.56	5.63	11.25	22.48	44.87	67.17	83.83
S80D 24B * 0503	0.61	6.14	12.28	24.52	48.93	73.23	91.38
S80D 25B * 0503	0.64	6.40	12.79	25.54	50.96	76.26	95.15
S80D 28B * 0503	0.72	7.16	14.32	28.60	57.05	85.34	106.46
S80D 30B * 0503	0.77	7.68	15.34	30.64	61.10	91.38	113.98
S80D 32B * 0503	0.82	8.19	16.36	32.67	65.14	97.41	121.49
S80D 36B * 0504	0.92	9.21	18.40	36.74	73.23	109.47	136.47
S80D 40B * 0504	1.02	10.23	20.44	40.81	81.30	121.49	151.40
S80D 45B * 0504	1.15	11.51	22.99	45.89	91.38	136.47	169.55

The above numerical values are Lewis formulas as reference only.
動力の換算式は P26 をご参照ください。
Please refer to the conversion formulas of power on page P26.

- 目次 CONTENTS
- インフォメーション INFORMATION
- ギヤボックス GEAR BOXES
- ノーバッキングバックラッシュギヤ ANTI BACKLASH SPUR GEARS
- 歯研研歯歯車 GROUND SPUR GEARS
- 平歯車 SPUR GEARS
- 内歯車 INTERNAL GEARS
- 歯研ラック GROUND RACKS
- ラック RACKS
- へリカル・スクリューギヤ HELICAL GEARS AND SCREW GEARS
- ワーム・ムーム・ワームギヤ WORMS AND WORM WHEELS
- かさ歯車 BEVEL GEARS
- スプロケット SPROCKETS
- 技術資料 REFERENCE DATA

平歯車

SPUR GEARS

モジュール **0.8** 圧力角 20° (並歯)
 MODULE 20° PRESSURE ANGLE FULL DEPTH TOOTH

JIS B 1702-1 (ISO) 9~10 級
 System of accuracy : JIS B 1702-1(ISO) class 9-10

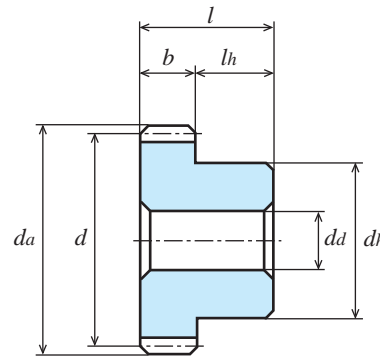

B1形
TYPE B1

ポリアセタール (白色)
 Material : Poly Acetal (White)

単位 : mm
 Dimensions : mm

商品記号 Catalogue Number	歯数 Number of Teeth z	基準円直径 Reference Diameter d	歯先円直径 Tip Diameter d_a	形 Type	歯幅 Face Width b	穴径 Bore Diameter d_d	ハブ外径 Hub Diameter d_h	ハブ長さ Hub Projection l_h	全長 Overall Length l	重量 Weight $W(g)$
S80D 48B - 0506	48	φ38.4	φ40	B1	5	φ6	φ14	9	14	9.6
S80D 50B - 0506	50	φ40	φ41.6	B1	5	φ6	φ14	9	14	10.3
S80D 56B - 0506	56	φ44.8	φ46.4	B1	5	φ6	φ14	9	14	12.6
S80D 60B - 0506	60	φ48	φ49.6	B1	5	φ6	φ14	9	14	14.2
S80D 64B - 0506	64	φ51.2	φ52.8	B1	5	φ6	φ14	9	14	15.9
S80D 70B - 0508	70	φ56	φ57.6	B1	5	φ8	φ16	9	14	19.0
S80D 72B - 0508	72	φ57.6	φ59.2	B1	5	φ8	φ16	9	14	20.1
S80D 80B - 0508	80	φ64	φ65.6	B1	5	φ8	φ16	9	14	24.2
S80D 90B - 0508	90	φ72	φ73.6	B1	5	φ8	φ20	9	14	31.7
S80D 100B - 0508	100	φ80	φ81.6	B1	5	φ8	φ24	9	14	40.2
S80D 120B - 0508	120	φ96	φ97.6	B1	5	φ8	φ30	9	14	59.0

波形スプリングピン付き、歯数 48 ~ 64 呼び径は φ1 です。(ステンレス) No. of teeth from 48B to 64B gears with Corrugated spring (SUS) as dimension of φ1.0.
 歯数 70 ~ 100 呼び径は φ1.4 です。(ステンレス) No. of teeth from 70B to 100B gears with Corrugated spring (SUS) as dimension of φ1.4.
 歯数 108 ~ 120 にはついておりません。 No. of teeth from 108B to 120B gears without Corrugated spring (SUS).

目次 CONTENTS
 インフォメーション INFORMATION
 ギヤボックス GEAR BOXES
 ノーバックラッシュギヤ ANTI BACKLASH SPUR GEARS
 歯研平歯車 GROUND SPUR GEARS
 平歯車 SPUR GEARS
 内歯車 INTERNAL GEARS
 歯研ラック GROUND RACKS
 ラック RACKS
 ヘリカルスcrewギヤ HELICAL GEARS AND SCREW GEARS
 ワーム WORMS AND WORM WHEELS
 かさ歯車 BEVEL GEARS
 スプロケット SPURGEETS
 技術資料 REFERENCE DATA

平歯車 SPUR GEARS

モジュール **0.8** 圧力角 20° (並歯)
MODULE 20° PRESSURE ANGLE FULL DEPTH TOOTH

JIS B 1702-1 (ISO) 9~10 級
System of accuracy : JIS B 1702-1(ISO) class 9-10



御注文には必ず“フルネームで商品記号”を明記してください。
Please refer to the catalogue reference while ordering.

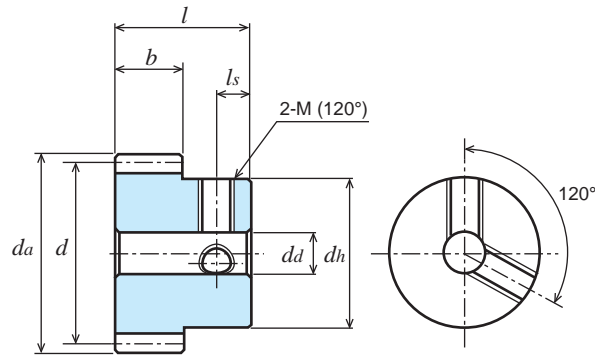

B1形
TYPE B1

ポリアセタール (白色)
Material : Poly Acetal (White)

単位 : mm
Dimensions : mm

商品記号 Catalogue Number	歯数 Number of Teeth <i>z</i>	基準円直径 Reference Diameter <i>d</i>	歯先円直径 Tip Diameter <i>da</i>	形 Type	歯幅 Face Width <i>b</i>	穴径 Bore Diameter <i>dd</i>	ハブ外径 Hub Diameter <i>dh</i>	ハブ長さ Hub Projection <i>lh</i>	全長 Overall Length <i>l</i>	ねじ Set Screw		重量 Weight <i>W(g)</i>
										2-M(120°)	<i>ls</i>	
S80D 48B * 0504	48	φ38.4	φ40	B1	5	φ4	φ22	7	12	2-M4	4	11.7
S80D 50B * 0504	50	φ40	φ41.6	B1	5	φ4	φ22	7	12	2-M4	4	12.4
S80D 56B * 0504	56	φ44.8	φ46.4	B1	5	φ4	φ22	7	12	2-M4	4	14.6
S80D 60B * 0504	60	φ48	φ49.6	B1	5	φ4	φ22	7	12	2-M4	4	16.3
S80D 64B * 0504	64	φ51.2	φ52.8	B1	5	φ4	φ22	7	12	2-M4	4	18.0
S80D 70B * 0505	70	φ56	φ57.6	B1	5	φ5	φ24	7	12	2-M4	4	21.5
S80D 72B * 0505	72	φ57.6	φ59.2	B1	5	φ5	φ24	7	12	2-M4	4	22.5
S80D 80B * 0505	80	φ64	φ65.6	B1	5	φ5	φ24	7	12	2-M4	4	26.8
S80D 90B * 0505	90	φ72	φ73.6	B1	5	φ5	φ24	7	12	2-M4	4	32.8
S80D 100B * 0505	100	φ80	φ81.6	B1	5	φ5	φ24	7	12	2-M4	4	39.5
S80D 120B * 0505	120	φ96	φ97.6	B1	5	φ5	φ24	7	12	2-M4	4	55.1

【*】(アスタ)にはセットスクリーが2個付いております。
[*]: Gear with two threaded holes / with two set screws.

許容伝達動力表 曲げ強さ (W)

Allowable transfer capability table (W) Bending Strength

商品記号 Catalogue Numbers	回転速度 (min ⁻¹) revolution/min						
	10	100	200	400	800	1,200	1,500
S80D 48B * 0504	1.23	12.28	24.52	48.93	97.41	145.44	180.36
S80D 50B * 0504	1.28	12.79	25.54	50.96	101.44	151.40	187.53
S80D 56B * 0504	1.43	14.32	28.60	57.05	113.48	168.83	208.87
S80D 60B * 0504	1.54	15.34	30.64	61.10	121.49	180.36	222.96
S80D 64B * 0504	1.64	16.36	32.67	65.14	129.49	191.81	236.94
S80D 70B * 0505	1.79	17.89	35.73	71.21	141.46	208.87	257.71
S80D 72B * 0505	1.84	18.40	36.74	73.23	145.44	214.52	264.58
S80D 80B * 0505	2.05	20.44	40.81	81.30	161.10	236.94	291.72
S80D 90B * 0505	2.30	22.99	45.89	91.38	180.36	264.58	323.84
S80D 100B * 0505	2.56	25.54	50.96	101.44	199.41	291.72	355.00
S80D 120B * 0505	3.07	30.64	61.10	121.49	236.94	342.65	414.26

The above numerical values are Lewis formulas as reference only.
動力の換算式は P26 をご参照ください。
Please refer to the conversion formulas of power on page P26.

目次
CONTENTS

インフォメーション
INFORMATION

ギヤボックス
GEAR BOXES

ノーバックラッシュギヤ
ANTI BACKLASH SPUR GEARS

歯研歯車
GROUND SPUR GEARS

平歯車
SPUR GEARS

内歯車
INTERNAL GEARS

歯研ラック
GROUND RACKS

ラック
RACKS

へリカル・スクリューギヤ
HELICAL GEARS AND SCREW GEARS

ウォーム・ウォームギヤ
WORMS AND WORM GEARS

かさ歯車
BEVEL GEARS

スプロケット
SPROCKETS

技術データ
REFERENCE DATA

ステンレス平歯車

SPUR GEARS

モジュール **0.8** 圧力角 20° (並歯)
 MODULE 20° PRESSURE ANGLE FULL DEPTH TOOTH

JIS B 1702-1 (ISO) 9 級
 System of accuracy : JIS B 1702-1(ISO) class 9

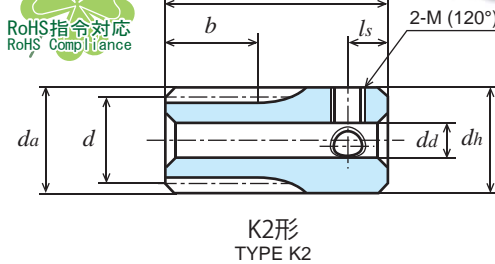

New **ねじを2箇所 (120°配) にしました。**
 New item with two threaded holes (120°)

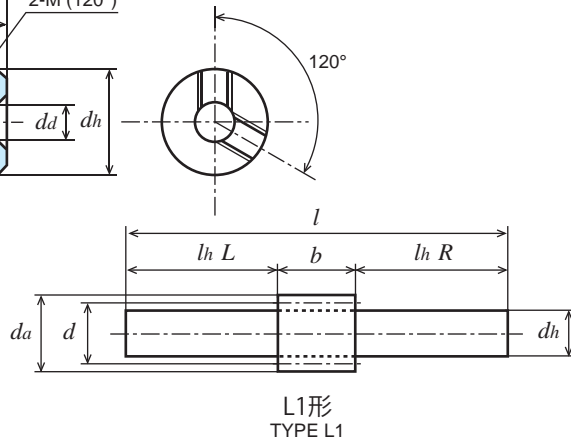

SUS304 ステンレス鋼棒 (JIS G 4303)

Material : Stainless Steel SUS304 (JIS G 4303)

単位 : mm
 Dimensions : mm

商品記号 Catalogue Number	歯数 Number of Teeth z	基準円直径 Reference Diameter d	歯先円直径 Tip Diameter da	形 Type	歯幅 Face Width b	穴径 Bore Diameter da(H8)	ハブ外径 Hub Diameter dh	ハブ長さ Hub Projection lh	全長 Overall Length l	ねじ Set Screw		重量 Weight W(g)
										2-M(120°)	ls	
S80SU 10K - 1010	10	φ 8	φ 9.6	K1	10	-	φ10	50	60	-	-	35.1
S80SU 12K - 1012	12	φ 9.6	φ 11.2	K1	10	-	φ12	50	60	-	-	50.6
S80SU 14K * 0704	14	φ 11.2	φ 12.8	K2	7	φ4	φ12.8	13	20	2-M3	3	16.3
S80SU 14L - 0706	14	φ 11.2	φ 12.8	L1	7	-	φ 6 (h9)	L28 R60	95	-	-	25.2
S80SU 15K * 0704	15	φ 12	φ 13.6	K2	7	φ4	φ13.6	13	20	2-M3	3	18.8
S80SU 15L - 0706	15	φ 12	φ 13.6	L1	7	-	φ 6 (h9)	L28 R60	95	-	-	26.0
S80SU 16L - 0706	16	φ 12.8	φ 14.4	L1	7	-	φ 6 (h9)	L28 R60	95	-	-	26.9
S80SU 16B * 0504	16	φ 12.8	φ 14.4	B1	5	φ4	φ10	7	12	2-M3	3	8.0
S80SU 16B * 0704	16	φ 12.8	φ 14.4	B1	7	φ4	φ10	7	14	2-M3	3	9.8
S80SU 18L - 0708	18	φ 14.4	φ 16	L1	7	-	φ 8 (h9)	L28 R60	95	-	-	44.1
S80SU 18B * 0504	18	φ 14.4	φ 16	B1	5	φ4	φ10	7	12	2-M3	3	9.3
S80SU 18B * 0704	18	φ 14.4	φ 16	B1	7	φ4	φ10	7	14	2-M3	3	11.7
S80SU 20L - 0710	20	φ 16	φ 17.6	L1	7	-	φ10 (h9)	L28 R60	95	-	-	66.0
S80SU 20B * 0504	20	φ 16	φ 17.6	B1	5	φ4	φ10	7	12	2-M3	3	10.9
S80SU 20B * 0704	20	φ 16	φ 17.6	B1	7	φ4	φ10	7	14	2-M3	3	13.9

SUS304 の商品にはセットスクリューは付いておりません。[*]: Gear with two threaded holes / without set screw.

許容伝達動力表 曲げ強さ (W)

Allowable transfer capability table (W) Bending Strength

商品記号 Catalogue Numbers	回転速度 (min ⁻¹) revolution/min						
	10	100	200	400	800	1,200	1,500
S80SU 10K - 1010	0.78	7.76	15.52	31.03	62.07	93.10	116.37
S80SU 12K - 1012	1.09	10.87	21.73	43.46	86.93	130.39	162.99
S80SU 14K * 0704	0.99	9.91	19.83	39.66	79.32	118.98	148.72
S80SU 14L - 0706	0.99	9.91	19.83	39.66	79.32	118.98	148.72
S80SU 15K * 0704	1.11	11.11	22.22	44.45	88.89	133.34	166.67
S80SU 15L - 0706	1.11	11.11	22.22	44.45	88.89	133.34	166.67
S80SU 16L - 0706	1.23	12.33	24.66	49.32	98.65	147.97	184.82
S80SU 16B * 0504	0.88	8.81	17.62	35.23	70.46	105.70	132.01
S80SU 16B * 0704	1.23	12.33	24.66	49.32	98.65	147.97	184.82
S80SU 18L - 0708	1.48	14.82	29.65	59.29	118.59	177.88	218.07
S80SU 18B * 0504	1.06	10.59	21.18	42.35	84.70	127.06	155.76
S80SU 18B * 0704	1.48	14.82	29.65	59.29	118.59	177.88	218.07
S80SU 20L - 0710	1.74	17.40	34.81	69.62	139.24	208.69	251.40
S80SU 20B * 0504	1.24	12.43	24.86	49.73	99.46	149.07	179.57
S80SU 20B * 0704	1.74	17.40	34.81	69.62	139.24	208.69	251.40

The above numerical values are equivalent to JGMA formulas as reference only.

動力の換算式は P26 をご参照ください。

Please refer to the conversion formulas of power on page P26.

ステンレス平歯車

SPUR GEARS

モジュール **0.8** 圧力角 20° (並歯)
 MODULE 20° PRESSURE ANGLE FULL DEPTH TOOTH

JIS B 1702-1 (ISO) 9級
 System of accuracy : JIS B 1702-1(ISO) class 9



御注文には必ず“フルネームで商品記号”を明記してください。
 Please refer to the catalogue reference while ordering.

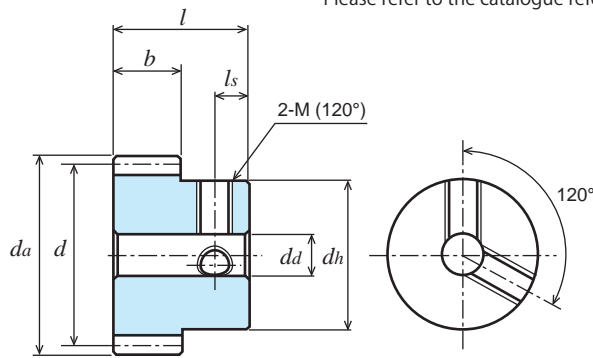

B1形
TYPE B1

SUS304 ステンレス鋼棒 (JIS G 4303)

Material : Stainless Steel SUS304 (JIS G 4303)

単位 : mm
 Dimensions : mm

商品記号 Catalogue Number	歯数 Number of Teeth z	基準円直径 Reference Diameter d	歯先円直径 Tip Diameter da	形 Type	歯幅 Face Width b	穴径 Bore Diameter da(H8)	ハブ外径 Hub Diameter dh	ハブ長さ Hub Projection lh	全長 Overall Length l	ねじ Set Screw		重量 Weight W(g)
										2-M(120°)	ls	
S80SU 22B * 0504	22	φ17.6	φ19.2	B1	5	φ4	φ10	7	12	2-M3	3	12.5
S80SU 22B * 0704	22	φ17.6	φ19.2	B1	7	φ4	φ10	7	14	2-M3	3	16.2
S80SU 24B * 0505	24	φ19.2	φ20.8	B1	5	φ5	φ15	7	12	2-M4	4	18.6
S80SU 24B * 0705	24	φ19.2	φ20.8	B1	7	φ5	φ15	7	14	2-M4	4	22.9
S80SU 25B * 0505	25	φ20	φ21.6	B1	5	φ5	φ15	7	12	2-M4	4	19.6
S80SU 25B * 0705	25	φ20	φ21.6	B1	7	φ5	φ15	7	14	2-M4	4	24.2
S80SU 28B * 0505	28	φ22.4	φ24	B1	5	φ5	φ15	7	12	2-M4	4	22.7
S80SU 28B * 0705	28	φ22.4	φ24	B1	7	φ5	φ15	7	14	2-M4	4	28.7
S80SU 30B * 0505	30	φ24	φ25.6	B1	5	φ5	φ15	7	12	2-M4	4	25.0
S80SU 30B * 0705	30	φ24	φ25.6	B1	7	φ5	φ15	7	14	2-M4	4	31.9
S80SU 32B * 0505	32	φ25.6	φ27.2	B1	5	φ5	φ15	9	14	2-M4	4	30.0
S80SU 36B * 0506	36	φ28.8	φ30.4	B1	5	φ6	φ18	9	14	2-M4	4	39.9
S80SU 40B * 0506	40	φ32	φ33.6	B1	5	φ6	φ18	9	14	2-M4	4	45.9
S80SU 45B * 0506	45	φ36	φ37.6	B1	5	φ6	φ18	9	14	2-M4	4	54.4
S80SU 48B * 0506	48	φ38.4	φ40	B1	5	φ6	φ18	9	14	2-M4	4	59.9
S80SU 50B * 0506	50	φ40	φ41.6	B1	5	φ6	φ18	9	14	2-M4	4	63.9

SUS304の商品にはセットスクリューは付いておりません。[*]: Gear with two threaded holes / without set screw.

許容伝達動力表 曲げ強さ (W)

Allowable transfer capability table (W) Bending Strength

商品記号 Catalogue Numbers	回転速度 (min ⁻¹) revolution/min						
	10	100	200	400	800	1,200	1,500
S80SU 22B * 0504	1.43	14.30	28.61	57.22	114.44	168.97	202.93
S80SU 22B * 0704	2.00	20.03	40.05	80.10	160.21	236.56	284.10
S80SU 24B * 0505	1.62	16.21	32.41	64.83	129.66	188.65	225.90
S80SU 24B * 0705	2.27	22.69	45.38	90.76	181.52	264.10	316.25
S80SU 25B * 0505	1.72	17.17	34.34	68.69	137.37	198.42	237.26
S80SU 25B * 0705	2.40	24.04	48.08	96.16	192.32	277.79	332.16
S80SU 28B * 0505	2.10	20.10	40.21	80.41	160.83	227.34	270.71
S80SU 28B * 0705	2.81	28.14	56.29	112.58	225.16	318.28	379.00
S80SU 30B * 0505	2.21	22.07	44.15	88.30	176.45	246.13	292.31
S80SU 30B * 0705	3.09	30.90	61.81	123.61	247.03	344.58	409.23
S80SU 32B * 0505	2.41	24.07	48.14	96.28	190.50	264.69	313.54
S80SU 36B * 0506	2.81	28.11	56.23	112.45	218.15	300.82	354.57
S80SU 40B * 0506	3.22	32.21	64.41	128.83	245.14	335.60	393.73
S80SU 45B * 0506	3.74	37.36	74.71	149.42	277.69	376.92	439.78
S80SU 48B * 0506	4.05	40.48	80.96	161.92	296.75	400.82	466.79
S80SU 50B * 0506	4.26	42.57	85.14	170.29	309.24	416.36	488.56

The above numerical values are equivalent to JGMA formulas as reference only.

動力の換算式は P26 をご参照ください。

Please refer to the conversion formulas of power on page P26.

- 目次 CONTENTS
- インフォメーション INFORMATION
- ギヤボックス GEAR BOXES
- ノーバッキングギヤ AMI BACKLASH SPUR GEARS
- 歯研平歯車 GROUND SPUR GEARS
- 平歯車 SPUR GEARS
- 内歯車 INTERNAL GEARS
- 歯研ラック GROUND RACKS
- ラック RACKS
- ハニカム・スクリューギヤ HELICAL GEARS AND SCREW GEARS
- ウォーム・ウォームギヤ WORMS AND WORM GEARS
- かさ歯車 BEVEL GEARS
- スプロケット SPROCKETS
- 技術仕様書 REFERENCE DATA

ステンレス平歯車

SPUR GEARS

モジュール **0.8** 圧力角 20° (並歯)
 MODULE 20° PRESSURE ANGLE FULL DEPTH TOOTH

JIS B 1702-1 (ISO) 9級
 System of accuracy : JIS B 1702-1(ISO) class 9



New **ねじを2箇所 (120°配) にしました。**
締結力が1.6倍になりました。
 New item with two threaded holes (120°)
 Tightening power increased by 1.6 times.

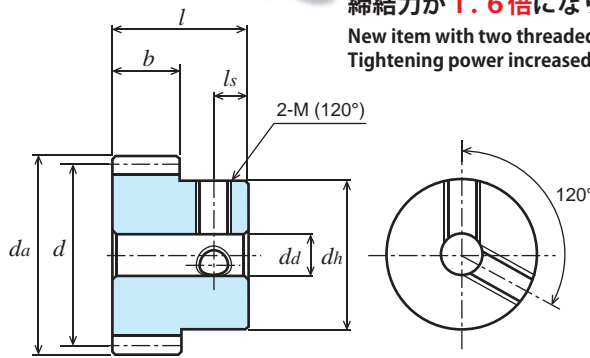

B1形
 TYPE B1

SUS304 ステンレス鋼棒 (JIS G 4303)

Material : Stainless Steel SUS304 (JIS G 4303)

単位 : mm
 Dimensions : mm

商品記号 Catalogue Number	歯数 Number of Teeth z	基準円直径 Reference Diameter d	歯先円直径 Tip Diameter da	形 Type	歯幅 Face Width b	穴径 Bore Diameter da(H8)	ハブ外径 Hub Diameter dh	ハブ長さ Hub Projection lh	全長 Overall Length l	ねじ Set Screw		重量 Weight W(g)
										2-M(120°)	ls	
S80SU 54B * 0506	54	φ43.2	φ44.8	B1	5	φ 6	φ18	9	14	2-M4	4	72.1
S80SU 56B * 0506	56	φ44.8	φ46.4	B1	5	φ 6	φ18	9	14	2-M4	4	76.5
S80SU 60B * 0506	60	φ48	φ49.6	B1	5	φ 6	φ18	9	14	2-M4	4	85.8
S80SU 64B * 0506	64	φ51.2	φ52.8	B1	5	φ 6	φ18	9	14	2-M4	4	95.7
S80SU 70B * 0508	70	φ56	φ57.6	B1	5	φ 8	φ28	9	14	2-M4	4	134.4
S80SU 72B * 0508	72	φ57.6	φ59.2	B1	5	φ 8	φ28	9	14	2-M4	4	140.0
S80SU 80B * 0508	80	φ64	φ65.6	B1	5	φ 8	φ28	9	14	2-M4	4	164.3
S80SU 80B * 0510	80	φ64	φ65.6	B1	5	φ10	φ28	9	14	2-M4	4	161.3
S80SU 90B * 0508	90	φ72	φ73.6	B1	5	φ 8	φ28	9	14	2-M4	4	198.1
S80SU 100B * 0508	100	φ80	φ81.6	B1	5	φ 8	φ28	9	14	2-M4	4	236.0
S80SU 100B * 0510	100	φ80	φ81.6	B1	5	φ10	φ28	9	14	2-M4	4	233.0
S80SU 120B * 0508	120	φ96	φ97.6	B1	5	φ 8	φ30	9	14	2-M4	4	330.0
S80SU 120B * 0510	120	φ96	φ97.6	B1	5	φ10	φ30	9	14	2-M4	4	327.1

SUS304の商品にはセットスクリューは付いておりません。
 [*] : Gear with two threaded holes / without set screw.

許容伝達動力表 曲げ強さ (W)

Allowable transfer capability table (W) Bending Strength

商品記号 Catalogue Numbers	回転速度 (min ⁻¹) revolution/min						
	10	100	200	400	800	1,200	1,500
S80SU 54B * 0506	4.68	46.77	93.55	187.10	333.68	446.48	531.67
S80SU 56B * 0506	4.89	48.88	97.77	195.54	345.63	461.09	553.02
S80SU 60B * 0506	5.31	53.12	106.24	212.30	369.00	490.02	595.27
S80SU 64B * 0506	5.74	57.37	114.74	227.01	391.70	525.18	636.94
S80SU 70B * 0508	6.38	63.77	127.55	248.65	424.50	577.17	698.30
S80SU 72B * 0508	6.59	65.92	131.83	255.75	435.12	594.31	718.46
S80SU 80B * 0508	7.45	74.51	149.02	283.56	476.06	661.79	797.82
S80SU 80B * 0510	7.45	74.51	149.02	283.56	476.06	661.79	797.82
S80SU 90B * 0508	8.52	85.20	170.40	316.67	523.99	742.92	898.85
S80SU 100B * 0508	9.60	96.01	192.03	348.72	582.97	822.44	998.20
S80SU 100B * 0510	9.60	96.01	192.03	348.72	582.97	822.44	998.20
S80SU 120B * 0508	11.77	117.73	235.28	408.93	697.12	984.92	1,189.46
S80SU 120B * 0510	11.77	117.73	235.28	408.93	697.12	984.92	1,189.46

The above numerical values are equivalent to JGMA formulas as reference only.
 動力の換算式は P26 をご参照ください。
 Please refer to the conversion formulas of power on page P26.

Memo

目次
CONTENTS

インフォメーション
INFORMATION

ギヤボックス
GEAR BOXES

ノーバッキングギヤ
ANTI BACKLASH SPUR GEARS

歯研削平歯
GROUND SPUR GEARS

平歯
SPUR GEARS

内歯
INTERNAL GEARS

歯研削ラック
GROUND RACKS

ラック
RACKS

へりかた・スクリューギヤ
HELICAL GEARS AND SCREW GEARS

ワーム・ワームホイール
WORMS AND WORM WHEELS

かみ歯
BEVEL GEARS

スプロケット
SPROCKETS

技術資料
REFERENCE DATA

平歯車 SPUR GEARS

モジュール **0.8** 圧力角 20° (並歯)
MODULE 20° PRESSURE ANGLE FULL DEPTH TOOTH

JIS B 1702-1 (ISO) 9級
System of accuracy : JIS B 1702-1(ISO) class 9

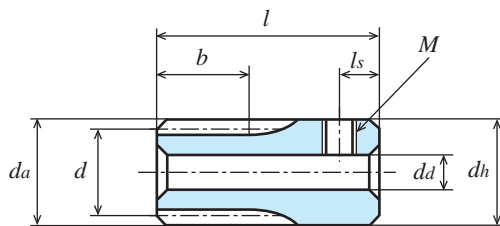

K2形
TYPE K2

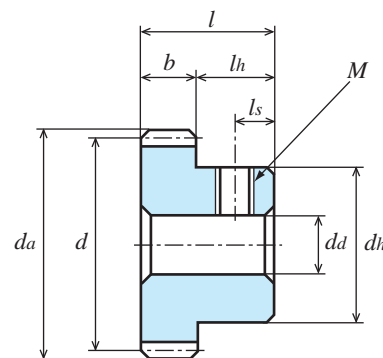

B1形
TYPE B1

C3604B 快削黄銅棒 (JIS H 3250) Material : Brass (ISO CuZn39Pb3)

単位 : mm
Dimensions : mm

商品記号 Catalogue Number	歯数 Number of Teeth z	基準円直径 Reference Diameter d	歯先円直径 Tip Diameter da	形 Type	歯幅 Face Width b	穴径 Bore Diameter da(H8)	ハブ外径 Hub Diameter dh	ハブ長さ Hub Projection lh	全長 Overall Length l	ねじ Set Screw		重量 Weight W(g)
										M	ls	
S80B 14K + 0704	14	φ11.2	φ12.8	K2	7	φ4	φ12.8	13	20	M3	3	17.8
S80B 15K + 0704	15	φ12	φ13.6	K2	7	φ4	φ13.6	13	20	M3	3	20.4
S80B 16B + 0504	16	φ12.8	φ14.4	B1	5	φ4	φ10	9	14	M3	3	9.8
S80B 16B + 0704	16	φ12.8	φ14.4	B1	7	φ4	φ10	7	14	M3	3	10.7
S80B 18B + 0504	18	φ14.4	φ16	B1	5	φ4	φ10	9	14	M3	3	11.3
S80B 18B + 0704	18	φ14.4	φ16	B1	7	φ4	φ10	7	14	M3	3	12.7
S80B 20B + 0504	20	φ16	φ17.6	B1	5	φ4	φ10	9	14	M3	3	12.9
S80B 20B + 0704	20	φ16	φ17.6	B1	7	φ4	φ10	7	14	M3	3	15.0
S80B 24B + 0505	24	φ19.2	φ20.8	B1	5	φ5	φ12.5	9	14	M3	3	19.2
S80B 24B + 0705	24	φ19.2	φ20.8	B1	7	φ5	φ12.5	7	14	M3	3	22.0
S80B 25B + 0505	25	φ20	φ21.6	B1	5	φ5	φ12.5	9	14	M3	3	20.2
S80B 25B + 0705	25	φ20	φ21.6	B1	7	φ5	φ12.5	7	14	M3	3	23.5
S80B 28B + 0505	28	φ22.4	φ24	B1	5	φ5	φ12.5	9	14	M3	3	23.6
S80B 28B + 0705	28	φ22.4	φ24	B1	7	φ5	φ12.5	7	14	M3	3	28.2
S80B 30B + 0505	30	φ24	φ25.6	B1	5	φ5	φ12.5	9	14	M3	3	26.1
S80B 30B + 0705	30	φ24	φ25.6	B1	7	φ5	φ12.5	7	14	M3	3	31.7
S80B 32B + 0505	32	φ25.6	φ27.2	B1	5	φ5	φ12.5	9	14	M3	4	28.8

【+】にはセットスクリューは付いております。
【+】: Gear with threaded hole / with set screw.

許容伝達動力表 曲げ強さ (W)

Allowable transfer capability table (W) Bending Strength

商品記号 Catalogue Numbers	回転速度 (min ⁻¹) revolution/min						
	10	100	200	400	800	1,200	1,500
S80B 14K + 0704	0.40	3.97	7.93	15.86	31.73	47.59	59.49
S80B 15K + 0704	0.44	4.44	8.89	17.78	35.56	53.33	66.67
S80B 16B + 0504	0.35	3.52	7.05	14.09	28.19	42.28	52.81
S80B 16B + 0704	0.49	4.93	9.86	19.73	39.46	59.19	73.93
S80B 18B + 0504	0.42	4.24	8.47	16.94	33.88	50.82	62.30
S80B 18B + 0704	0.59	5.93	11.86	23.72	47.43	71.15	87.23
S80B 20B + 0504	0.50	4.97	9.95	19.89	39.78	59.63	71.83
S80B 20B + 0704	0.70	6.96	13.92	27.85	55.70	83.48	100.56
S80B 24B + 0505	0.65	6.48	12.97	25.93	51.86	75.46	90.36
S80B 24B + 0705	0.91	9.08	18.15	36.30	72.61	105.64	126.50
S80B 25B + 0505	0.69	6.87	13.74	27.47	54.95	79.37	94.90
S80B 25B + 0705	0.96	9.62	19.23	38.46	76.93	111.12	132.87
S80B 28B + 0505	0.80	8.04	16.08	32.17	64.33	90.94	108.29
S80B 28B + 0705	1.13	11.26	22.52	45.03	90.06	127.31	151.60
S80B 30B + 0505	0.88	8.83	17.66	35.32	70.58	98.45	116.92
S80B 30B + 0705	1.24	12.36	24.72	49.45	98.81	137.88	163.69
S80B 32B + 0505	0.96	9.63	19.26	38.51	76.20	105.88	125.42

The above numerical values are equivalent to JGMA formulas as reference only.

動力の換算式は P26 をご参照ください。

Please refer to the conversion formulas of power on page P26.

RoHS 対応

2006年11月生産開始分より欧州 RoHS 指令に対応できる商品を提供しています。

We supplied the KG-products with RoHS compliance of EU to all our valued customers since November 2006

平歯車

SPUR GEARS

モジュール **0.8** 圧力角 20° (並歯)
 MODULE 20° PRESSURE ANGLE FULL DEPTH TOOTH

JIS B 1702-1 (ISO) 9 級
 System of accuracy : JIS B 1702-1(ISO) class 9



御注文には必ず “フルネームで商品記号” を明記してください。
 Please refer to the catalogue reference while ordering.

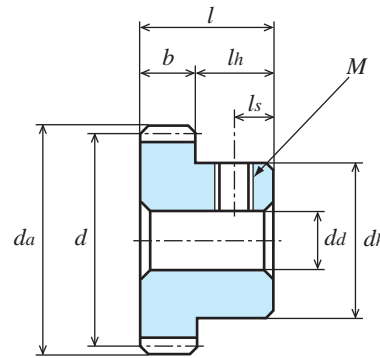

B1形
 TYPE B1

C3604B 快削黄銅棒、C3771B 鍛造用黄銅
 Material : Brass (ISO CuZn39Pb3, ISO CuZn38Pb2)

単位 : mm
 Dimensions : mm

商品記号 Catalogue Number	歯数 Number of Teeth z	基準円直径 Reference Diameter d	歯先円直径 Tip Diameter da	形 Type	歯幅 Face Width b	穴径 Bore Diameter da(H8)	ハブ外径 Hub Diameter dh	ハブ長さ Hub Projection lh	全長 Overall Length l	ねじ Set Screw		重量 Weight W(g)
										M	ls	
S80B 36B + 0506	36	φ28.8	φ30.4	B1	5	φ6	φ14	9	14	M4	4	35.8
S80B 40B + 0506	40	φ32	φ33.6	B1	5	φ6	φ14	9	14	M4	4	42.3
S80B 45B + 0506	45	φ36	φ37.6	B1	5	φ6	φ14	9	14	M4	4	51.4
S80B 48B + 0506	48	φ38.4	φ40	B1	5	φ6	φ14	9	14	M4	4	57.3
S80B 50B + 0506	50	φ40	φ41.6	B1	5	φ6	φ14	9	14	M4	4	61.5
S80B 56B + 0506	56	φ44.8	φ46.4	B1	5	φ6	φ14	9	14	M4	4	75.1
S80B 60B + 0506	60	φ48	φ49.6	B1	5	φ6	φ14	9	14	M4	4	85.0
S80B 64B + 0506	64	φ51.2	φ52.8	B1	5	φ6	φ16	9	14	M4	4	99.1
S80B 70B + 0508	70	φ56	φ57.6	B1	5	φ8	φ16	9	14	M4	4	113.8
S80B 72B + 0508	72	φ57.6	φ59.2	B1	5	φ8	φ16	9	14	M4	4	119.8
S80B 80B + 0508	80	φ64	φ65.6	B1	5	φ8	φ16	9	14	M4	4	145.8
S80B 90B + 0508	90	φ72	φ73.6	B1	5	φ8	φ20	9	14	M4	4	190.6
S80B 100B + 0508	100	φ80	φ81.6	B1	5	φ8	φ24	9	14	M4	4	241.6
S80B 120B + 0508	120	φ96	φ97.6	B1	5	φ8	φ30	9	14	M4	4	354.8

【+】 セットスクリューは付いております。【+】 : Gear with threaded hole / with set screw.

許容伝達動力表 曲げ強さ (W)

Allowable transfer capability table (W) Bending Strength

商品記号 Catalogue Numbers	回転速度 (min ⁻¹) revolution/min						
	10	100	200	400	800	1,200	1,500
S80B 36B + 0506	1.12	11.25	22.49	44.98	87.26	120.33	141.83
S80B 40B + 0506	1.28	12.88	25.77	51.53	98.05	134.24	157.49
S80B 45B + 0506	1.49	14.94	29.88	59.77	111.08	150.77	175.91
S80B 48B + 0506	1.61	16.19	32.38	64.77	118.70	160.33	186.72
S80B 50B + 0506	1.70	17.03	34.06	68.12	123.70	166.54	195.42
S80B 56B + 0506	1.96	19.55	39.11	78.21	138.25	184.44	221.21
S80B 60B + 0506	2.12	21.25	42.49	84.92	147.60	196.01	238.11
S80B 64B + 0506	2.29	22.95	45.90	90.81	156.68	210.07	254.77
S80B 70B + 0508	2.55	25.51	51.02	99.46	169.80	230.87	297.32
S80B 72B + 0508	2.64	26.37	52.73	102.30	174.05	237.72	287.38
S80B 80B + 0508	2.98	29.80	59.61	113.43	190.42	264.72	319.13
S80B 90B + 0508	3.41	34.08	68.16	126.67	209.60	297.17	359.54
S80B 100B + 0508	3.84	38.40	76.81	139.49	233.19	328.98	399.28
S80B 120B + 0508	4.71	47.09	94.11	163.57	278.85	393.97	475.79

The above numerical values are equivalent to JGMA formulas as reference only.

動力の換算式は P26 をご参照ください。

Please refer to the conversion formulas of power on page P26.

RoHS 対応
 2006年11月生産開始分より欧州 RoHS 指令に対応できる商品を提供しています。
 We supplied the KG-products with RoHS compliance of EU to all our valued customers since November 2006

目次 CONTENTS

インフォメーション INFORMATION

ギヤボックス GEAR BOXES

ノーバックラッシュギヤ ANTI BACKLASH SPUR GEARS

歯研平歯車 GROUND SPUR GEARS

平歯車 SPUR GEARS

内歯車 INTERNAL GEARS

歯研ラック GROUND RACKS

ラック RACKS

らせん歯車とスクリュー HEICAL GEARS AND SCREW GEARS

ワームとワームホイール WORMS AND WORM WHEELS

かさ歯車 BEVEL GEARS

スプロケット SPROCKETS

技術資料 REFERENCE DATA

平歯車 SPUR GEARS

モジュール
MODULE

1

圧力角 20° (並歯)

20° PRESSURE ANGLE FULL DEPTH TOOTH

JIS B 1702-1 (ISO) 9~10 級
System of accuracy : JIS B 1702-1(ISO) class 9-10



ねじを2箇所 (120°配) にしました。
New item with two threaded holes (120°)

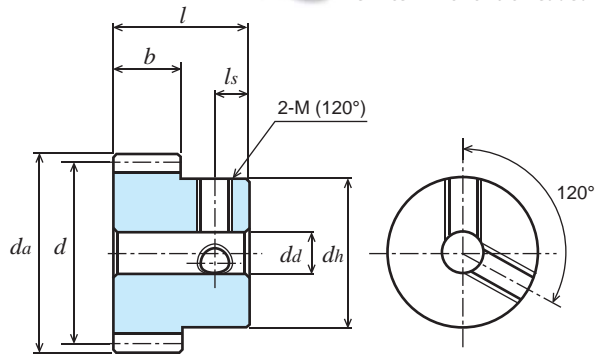

B1形
TYPE B1

ポリアセタール (白色)
Material : Poly Acetal (White)

単位 : mm
Dimensions : mm

商品記号 Catalogue Number	歯数 Number of Teeth z	基準円直径 Reference Diameter d	歯先円直径 Tip Diameter da	形 Type	歯幅 Face Width b	穴径 Bore Diameter da	ハブ外径 Hub Diameter dh	ハブ長さ Hub Projection lh	全長 Overall Length l	ねじ Set Screw		重量 Weight W(g)
										2-M(120°)	ls	
S1D 12A - 1206	12	φ12	φ14	A1	12	φ6	-	-	12			1.4
S1D 14A - 1206	14	φ14	φ16	A1	12	φ6	-	-	12			2.1
S1D 15A - 1206	15	φ15	φ17	A1	12	φ6	-	-	12			2.5
S1D 16A - 1206	16	φ16	φ18	A1	12	φ6	-	-	12			2.9
S1D 17B * 0804	17	φ17	φ19	B1	8	φ4	φ14	8	16	2-M4	4	4.0
S1D 18B * 0804	18	φ18	φ20	B1	8	φ4	φ15	8	16	2-M4	4	4.5
S1D 20B * 0805	20	φ20	φ22	B1	8	φ5	φ16	8	16	2-M4	4	5.3
S1D 22B * 0805	22	φ22	φ24	B1	8	φ5	φ18	8	16	2-M4	4	6.7
S1D 23B * 0805	23	φ23	φ25	B1	8	φ5	φ20	8	16	2-M4	4	7.7
S1D 24B * 0805	24	φ24	φ26	B1	8	φ5	φ20	8	16	2-M4	4	8.2
S1D 25B * 0805	25	φ25	φ27	B1	8	φ5	φ22	8	16	2-M4	4	9.3
S1D 26B * 0805	26	φ26	φ28	B1	8	φ5	φ22	8	16	2-M4	4	9.8
S1D 28B * 0805	28	φ28	φ30	B1	8	φ5	φ24	8	16	2-M4	4	11.6
S1D 30B * 0805	30	φ30	φ32	B1	8	φ5	φ24	8	16	2-M4	4	12.6

波形スプリングピン付き、歯数 12 ~ 16 呼び径は φ1 です。(ステンレス) No. of teeth from 12A to 16A gears with Corrugated spring (SUS) as dimension of φ1.0.
【*】(アスタ) にはセットスクリーが 2 個付いております。【*】: Gear with two threaded holes / with two set screws.

許容伝達動力表 曲げ強さ (W)

Allowable transfer capability table (W) Bending Strength

商品記号 Catalogue Numbers	回転速度 (min ⁻¹) revolution/min						
	10	100	200	400	800	1,200	1,500
S1D 12A - 1206	0.88	8.82	17.64	35.25	70.40	105.44	131.66
S1D 14A - 1206	1.03	10.29	20.57	41.11	82.09	122.93	153.47
S1D 15A - 1206	1.10	11.03	22.04	44.05	87.93	131.66	164.35
S1D 16A - 1206	1.18	11.76	23.51	46.98	93.77	140.39	175.23
S1D 17B * 0804	0.83	8.33	16.65	33.27	66.41	99.41	124.07
S1D 18B * 0804	0.88	8.82	17.63	35.22	70.30	105.22	131.31
S1D 20B * 0805	0.98	9.80	19.59	39.13	78.07	116.82	145.76
S1D 22B * 0805	1.08	10.78	21.54	43.03	85.83	128.41	160.19
S1D 23B * 0805	1.13	11.27	22.52	44.98	89.71	134.20	167.40
S1D 24B * 0805	1.18	11.76	23.50	46.93	93.59	139.98	174.60
S1D 25B * 0805	1.23	12.25	24.48	48.88	97.47	145.76	181.79
S1D 26B * 0805	1.27	12.74	25.45	50.83	101.34	151.54	188.98
S1D 28B * 0805	1.37	13.72	27.41	54.73	109.09	163.08	203.33
S1D 30B * 0805	1.47	14.70	29.36	58.62	116.82	174.60	217.65

The above numerical values are Lewis formulas as reference only.

動力の換算式は P26 をご参照ください。

Please refer to the conversion formula of power on page P26.

平歯車

SPUR GEARS

モジュール
MODULE

1

圧力角 20° (並歯)

20° PRESSURE ANGLE FULL DEPTH TOOTH

JIS B 1702-1 (ISO) 9~10 級
System of accuracy : JIS B 1702-1(ISO) class 9-10



御注文には必ず“フルネームで商品記号”を明記してください。
Please refer to the catalogue reference while ordering.

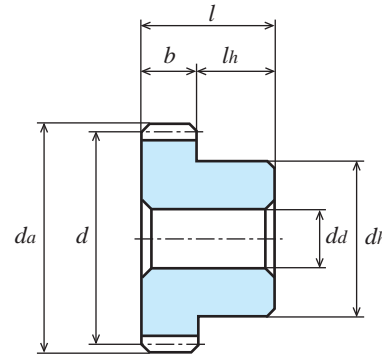

B1形
TYPE B1

ポリアセタール (白色)
Material : Poly Acetal (White)

単位 : mm
Dimensions : mm

商品記号 Catalogue Number	歯数 Number of Teeth <i>z</i>	基準円直径 Reference Diameter <i>d</i>	歯先円直径 Tip Diameter <i>da</i>	形 Type	歯幅 Face Width <i>b</i>	穴径 Bore Diameter <i>da</i>	ハブ外径 Hub Diameter <i>dh</i>	ハブ長さ Hub Projection <i>lh</i>	全長 Overall Length <i>l</i>	重量 Weight <i>W(g)</i>
S1D 17B - 0806	17	φ17	φ19	B1	8	φ6	φ14	8	16	3.7
S1D 18B - 0808	18	φ18	φ20	B1	8	φ8	φ15	8	16	3.7
S1D 20B - 0808	20	φ20	φ22	B1	8	φ8	φ16	8	16	4.7
S1D 22B - 0808	22	φ22	φ24	B1	8	φ8	φ18	8	16	6.0
S1D 23B - 0808	23	φ23	φ25	B1	8	φ8	φ18	8	16	6.4
S1D 24B - 0808	24	φ24	φ26	B1	8	φ8	φ18	8	16	6.8
S1D 25B - 0808	25	φ25	φ27	B1	8	φ8	φ18	8	16	7.3
S1D 26B - 0808	26	φ26	φ28	B1	8	φ8	φ20	8	16	8.4
S1D 28B - 0808	28	φ28	φ30	B1	8	φ8	φ20	8	16	9.4
S1D 30B - 0808	30	φ30	φ32	B1	8	φ8	φ20	8	16	10.4

波形スプリングピン付き、歯数 17 ~ 18 呼び径は φ1 です。(ステンレス)
歯数 20 ~ 80 呼び径は φ1.4 です。(ステンレス)

No. of teeth from 17B to 18B gears with Corrugated spring (SUS) as dimension of φ1.0.
No. of teeth from 20B to 80B gears with Corrugated spring (SUS) as dimension of φ1.4.

目次
CONTENTS

インフォメーション
INFORMATION

ギヤボックス
GEAR BOXES

ノーバッキングギヤ
ANTI BACKLASH SPUR GEARS

歯研削歯車
GROUND SPUR GEARS

平歯車
SPUR GEARS

内歯車
INTERNAL GEARS

歯研削ラック
GROUND RACKS

ラック
RACKS

ひかり・スチールギヤ
HELIICAL GEARS AND STEEL GEARS

ウォーム・ウォームホイール
WORMS AND WORM WHEELS

かさ歯車
BEVEL GEARS

スプロケット
SPROCKETS

技術資料
REFERENCE DATA

平歯車 SPUR GEARS

モジュール
MODULE

1

圧力角 20° (並歯)
20° PRESSURE ANGLE FULL DEPTH TOOTH

JIS B 1702-1 (ISO) 9~10 級
System of accuracy : JIS B 1702-1(ISO) class 9-10



New **ねじを2箇所 (120°配) にしました。**
New item with two threaded holes (120°)

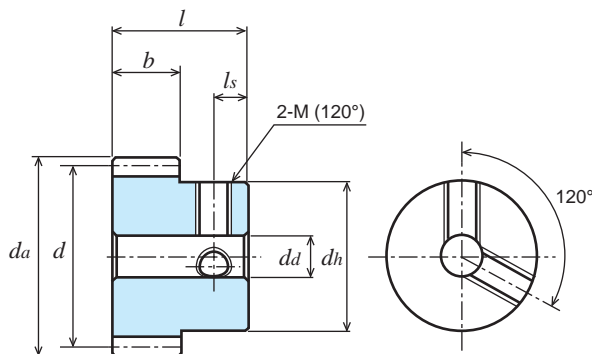

B1形
TYPE B1

ポリアセタール (白色)
Material : Poly Acetal (White)

単位 : mm
Dimensions : mm

商品記号 Catalogue Number	歯数 Number of Teeth z	基準円直径 Reference Diameter d	歯先円直径 Tip Diameter da	形 Type	歯幅 Face Width b	穴径 Bore Diameter da	ハブ外径 Hub Diameter dh	ハブ長さ Hub Projection lh	全長 Overall Length l	ねじ Set Screw		重量 Weight W(g)
										2-M(120°)	ls	
S1D 32B * 0605	32	φ32	φ34	B1	6	φ5	φ24	8	14	2-M4	4	11.5
S1D 34B * 0605	34	φ34	φ36	B1	6	φ5	φ24	8	14	2-M4	4	12.4
S1D 35B * 0605	35	φ35	φ37	B1	6	φ5	φ24	8	14	2-M4	4	12.8
S1D 36B * 0605	36	φ36	φ38	B1	6	φ5	φ24	8	14	2-M4	4	13.3
S1D 38B * 0605	38	φ38	φ40	B1	6	φ5	φ24	8	14	2-M4	4	14.3
S1D 40B * 0605	40	φ40	φ42	B1	6	φ5	φ24	8	14	2-M4	4	15.3
S1D 42B * 0605	42	φ42	φ44	B1	6	φ5	φ24	8	14	2-M4	4	16.4
S1D 44B * 0605	44	φ44	φ46	B1	6	φ5	φ24	8	14	2-M4	4	17.5
S1D 45B * 0605	45	φ45	φ47	B1	6	φ5	φ24	8	14	2-M4	4	18.1
S1D 48B * 0605	48	φ48	φ50	B1	6	φ5	φ24	8	14	2-M4	4	20.0
S1D 50B * 0605	50	φ50	φ52	B1	6	φ5	φ24	8	14	2-M4	4	21.3
S1D 52B * 0605	52	φ52	φ54	B1	6	φ5	φ24	8	14	2-M4	4	22.6
S1D 55B * 0605	55	φ55	φ57	B1	6	φ5	φ24	8	14	2-M4	4	24.8

【*】(アスタ)にはセットスクリーが2個付いております。

【*】: Gear with two threaded holes / with two set screws.

許容伝達動力表 曲げ強さ (W)

Allowable transfer capability table (W) Bending Strength

商品記号 Catalogue Numbers	回転速度 (min ⁻¹) revolution/min						
	10	100	200	400	800	1,200	1,500
S1D 32B * 0605	2.10	20.97	41.90	83.65	166.65	249.01	310.33
S1D 34B * 0605	2.23	22.28	44.52	88.85	176.98	264.39	328.97
S1D 35B * 0605	2.30	22.94	45.82	91.46	182.14	272.06	338.26
S1D 36B * 0605	2.36	23.59	47.13	94.06	187.30	279.73	347.53
S1D 38B * 0605	2.49	24.90	49.74	99.26	197.61	295.06	366.00
S1D 40B * 0605	2.62	26.21	52.36	104.46	207.91	310.33	384.38
S1D 42B * 0605	2.75	27.52	54.97	109.66	218.20	325.25	402.67
S1D 44B * 0605	2.89	28.83	57.58	114.85	228.48	340.12	420.87
S1D 48B * 0605	3.15	31.44	62.80	125.23	249.01	369.68	457.01
S1D 50B * 0605	3.28	32.75	65.40	130.42	259.26	384.38	474.95
S1D 52B * 0605	3.41	34.06	68.01	135.60	269.50	399.02	492.80
S1D 55B * 0605	3.61	36.02	71.92	143.37	284.84	420.87	519.41

The above numerical values are Lewis formulas as reference only.

動力の換算式は P26 をご参照ください。

Please refer to the conversion formula of power on page P26.

平歯車

SPUR GEARS

モジュール
MODULE

1

圧力角 20° (並歯)

20° PRESSURE ANGLE FULL DEPTH TOOTH

JIS B 1702-1 (ISO) 9~10 級
System of accuracy : JIS B 1702-1(ISO) class 9-10



御注文には必ず“フルネームで商品記号”を明記してください。
Please refer to the catalogue reference while ordering.

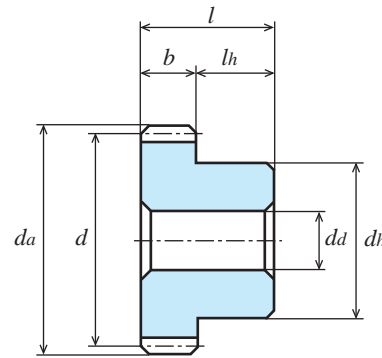

B1形
TYPE B1

ポリアセタール (白色)
Material : Poly Acetal (White)

単位 : mm
Dimensions : mm

商品記号 Catalogue Number	歯数 Number of Teeth <i>z</i>	基準円直径 Reference Diameter <i>d</i>	歯先円直径 Tip Diameter <i>da</i>	形 Type	歯幅 Face Width <i>b</i>	穴径 Bore Diameter <i>dd</i>	ハブ外径 Hub Diameter <i>dh</i>	ハブ長さ Hub Projection <i>lh</i>	全長 Overall Length <i>l</i>	重量 Weight <i>W(g)</i>
S1D 32B-0608	32	φ32	φ34	B1	6	φ8	φ20	8	14	9.4
S1D 34B-0608	34	φ34	φ36	B1	6	φ8	φ20	8	14	10.2
S1D 35B-0608	35	φ35	φ37	B1	6	φ8	φ20	8	14	10.7
S1D 36B-0608	36	φ36	φ38	B1	6	φ8	φ20	8	14	11.2
S1D 38B-0608	38	φ38	φ40	B1	6	φ8	φ20	8	14	12.2
S1D 40B-0608	40	φ40	φ42	B1	6	φ8	φ20	8	14	13.2
S1D 42B-0608	42	φ42	φ44	B1	6	φ8	φ20	8	14	14.3
S1D 44B-0608	44	φ44	φ46	B1	6	φ8	φ20	8	14	15.4
S1D 45B-0608	45	φ45	φ47	B1	6	φ8	φ20	8	14	16.0
S1D 48B-0608	48	φ48	φ50	B1	6	φ8	φ20	8	14	17.9
S1D 50B-0608	50	φ50	φ52	B1	6	φ8	φ20	8	14	19.2
S1D 52B-0608	52	φ52	φ54	B1	6	φ8	φ20	8	14	20.5
S1D 55B-0608	55	φ55	φ57	B1	6	φ8	φ20	8	14	22.7

波形スプリングピン付き、歯数 20 ~ 80 呼び径は φ1.4 です。(ステンレス) No. of teeth from 20B to 80B gears with Corrugated spring (SUS) as dimension of φ1.4.

目次
CONTENTS

インフォメーション
INFORMATION

ギヤボックス
GEAR BOXES

ノーバッキングバックラッシュギヤ
ANTI BACKLASH SPUR GEARS

歯研削歯車
GROUND SPUR GEARS

平歯車
SPUR GEARS

内歯車
INTERNAL GEARS

歯研削ラック
GROUND RACKS

ラック
RACKS

へリカル・スクリューギヤ
HELICAL GEARS AND SCREW GEARS

ウォーム・ウォームホイール
WORMS AND WORM WHEELS

かさ歯車
BEVEL GEARS

スプロケット
SPROCKETS

技術資料
REFERENCE DATA

平歯車 SPUR GEARS

モジュール
MODULE

1

圧力角 20° (並歯)

20° PRESSURE ANGLE FULL DEPTH TOOTH

JIS B 1702-1 (ISO) 9~10 級
System of accuracy : JIS B 1702-1(ISO) class 9-10



New **ねじを2箇所 (120°配) にしました。**
New item with two threaded holes (120°)

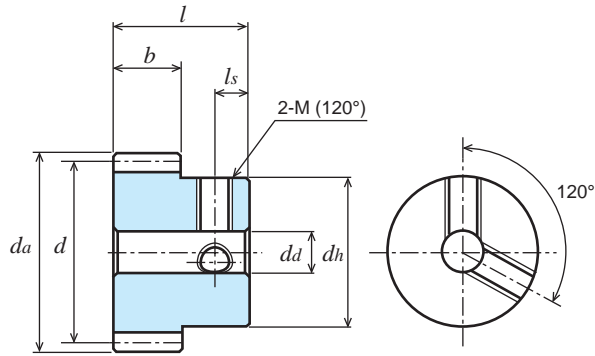

B1形
TYPE B1

ポリアセタール (白色)
Material : Poly Acetal (White)

単位 : mm
Dimensions : mm

商品記号 Catalogue Number	歯数 Number of Teeth z	基準円直径 Reference Diameter d	歯先円直径 Tip Diameter da	形 Type	歯幅 Face Width b	穴径 Bore Diameter da	ハブ外径 Hub Diameter dh	ハブ長さ Hub Projection lh	全長 Overall Length l	ねじ Set Screw		重量 Weight W(g)
										2-M(120°)	ls	
S1D 56B * 0605	56	φ 56	φ 58	B1	6	φ5	φ24	8	14	2-M4	4	25.5
S1D 60B * 0605	60	φ 60	φ 62	B1	6	φ5	φ24	8	14	2-M4	4	28.6
S1D 64B * 0605	64	φ 64	φ 66	B1	6	φ5	φ24	8	14	2-M4	4	31.9
S1D 70B * 0605	70	φ 70	φ 72	B1	6	φ5	φ24	8	14	2-M4	4	37.2
S1D 72B * 0605	72	φ 72	φ 74	B1	6	φ5	φ24	8	14	2-M4	4	39.1
S1D 80B * 0605	80	φ 80	φ 82	B1	6	φ5	φ24	8	14	2-M4	4	47.2
S1D 90B * 0605	90	φ 90	φ 92	B1	6	φ5	φ24	8	14	2-M4	4	58.5
S1D 100B * 0605	100	φ 100	φ 102	B1	6	φ5	φ24	8	14	2-M4	4	71.1
S1D 120B * 0605	120	φ 120	φ 122	B1	6	φ5	φ24	8	14	2-M4	4	100.4

【*】(アスタ)にはセットスクリーが2個付いております。
【*】: Gear with two threaded holes / with two set screws.

許容伝達動力表 曲げ強さ (W)

Allowable transfer capability table (W) Bending Strength

商品記号 Catalogue Numbers	回転速度 (min ⁻¹) revolution/min						
	10	100	200	400	800	1,200	1,500
S1D 56B * 0605	3.67	36.68	73.23	145.96	289.95	428.13	528.23
S1D 60B * 0605	3.94	39.29	78.44	156.31	310.33	457.01	563.31
S1D 64B * 0605	4.20	41.92	83.65	166.65	330.21	485.67	597.95
S1D 70B * 0605	4.59	45.82	91.46	182.14	359.85	528.23	647.51
S1D 72B * 0605	4.72	47.13	94.06	187.30	369.68	542.31	663.79
S1D 80B * 0605	5.25	52.36	104.46	207.91	408.74	597.95	727.65
S1D 90B * 0605	5.90	58.88	117.45	233.62	457.01	663.79	804.69
S1D 100B * 0605	6.56	65.40	130.42	259.26	504.65	727.65	875.66
S1D 120B * 0605	7.87	78.44	156.31	310.33	597.95	849.11	997.80

The above numerical values are Lewis formulas as reference only.
動力の換算式は P26 をご参照ください。
Please refer to the conversion formula of power on page P26.

JIS B 1702-1 (ISO) 9~10 級
System of accuracy: JIS B 1702-1(ISO) class 9-10



御注文には必ず“フルネームで商品記号”を明記してください。
Please refer to the catalogue reference while ordering.

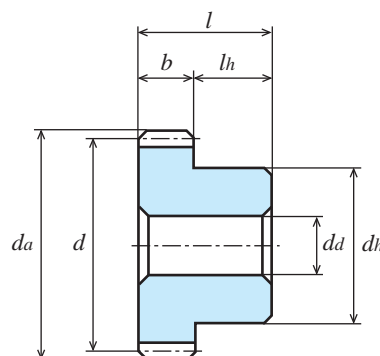

B1形
TYPE B1

ポリアセタール (白色)
Material: Poly Acetal (White)

単位: mm
Dimensions: mm

商品記号 Catalogue Number	歯数 Number of Teeth <i>z</i>	基準円直径 Reference Diameter <i>d</i>	歯先円直径 Tip Diameter <i>da</i>	形 Type	歯幅 Face Width <i>b</i>	穴径 Bore Diameter <i>dd</i>	ハブ外径 Hub Diameter <i>dh</i>	ハブ長さ Hub Projection <i>lh</i>	全長 Overall Length <i>l</i>	重量 Weight <i>W(g)</i>
S1D 56B-0608	56	φ 56	φ 58	B1	6	φ8	φ20	8	14	23.4
S1D 60B-0608	60	φ 60	φ 62	B1	6	φ8	φ20	8	14	26.5
S1D 64B-0608	64	φ 64	φ 66	B1	6	φ8	φ20	8	14	29.8
S1D 70B-0608	70	φ 70	φ 72	B1	6	φ8	φ20	8	14	35.1
S1D 72B-0608	72	φ 72	φ 74	B1	6	φ8	φ20	8	14	37.0
S1D 80B-0608	80	φ 80	φ 82	B1	6	φ8	φ20	8	14	45.1
S1D 90B-0608	90	φ 90	φ 92	B1	6	φ8	φ30	8	14	60.8
S1D 100B-0608	100	φ100	φ102	B1	6	φ8	φ30	8	14	73.4
S1D 120B-0608	120	φ120	φ122	B1	6	φ8	φ30	8	14	102.7

波形スプリングピン付き、歯数 20 ~ 80 呼び径は φ1.4 です。(ステンレス)
歯数 90 ~ 120 にはついておりません。

No. of teeth from 20B to 80B gears with Corrugated spring (SUS) as dimension of φ1.4.
No. of teeth from 90 to 120B gears without Corrugated spring.

平歯車 SPUR GEARS

モジュール
MODULE

1

圧力角 20° (並歯)

20° PRESSURE ANGLE FULL DEPTH TOOTH

JIS B 1702-1 (ISO) 9~10 級
System of accuracy : JIS B 1702-1(ISO) class 9-10

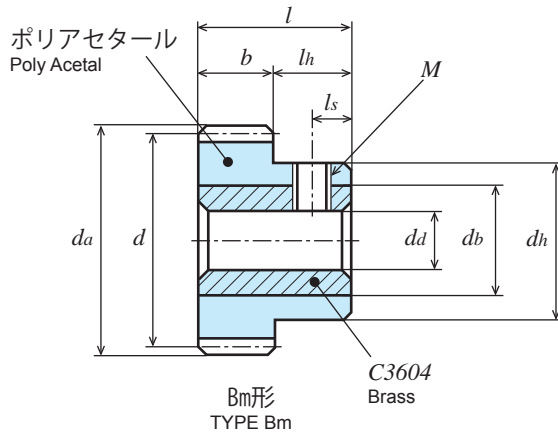

ポリアセタール (白色) 黄銅ブッシュ入り (C3604B) Material : Poly Acetal (White) with Brass Bushing

単位 : mm
Dimensions : mm

商品記号 Catalogue Number	歯数 Number of Teeth z	基準円直径 Reference Diameter d	歯先円直径 Tip Diameter da	形 Type	歯幅 Face Width b	穴径 Bore Diameter da(H8)	ハブ外径 Hub Diameter dh	ハブ長さ Hub Projection lh	全長 Overall Length l	ねじ Set Screw		ブッシュ外径 db	重量 Weight W(g)
										M	ls		
S1DB 20B + 1008	20	φ20	φ22	Bm	10	φ 8	φ16	10	20	M4	4	φ12	16.8
S1DB 24B + 1008	24	φ24	φ26	Bm	10	φ 8	φ20	10	20	M4	4	φ12	17.5
S1DB 25B + 1008	25	φ25	φ27	Bm	10	φ 8	φ20	10	20	M4	4	φ12	18.0
S1DB 28B + 1010	28	φ28	φ30	Bm	10	φ10	φ24	10	20	M4	4	φ16	35.0
S1DB 30B + 1010	30	φ30	φ32	Bm	10	φ10	φ24	10	20	M4	4	φ16	36.4
S1DB 32B + 1010	32	φ32	φ34	Bm	10	φ10	φ24	10	20	M4	4	φ16	37.8
S1DB 36B + 1010	36	φ36	φ38	Bm	10	φ10	φ30	10	20	M4	4	φ16	38.0
S1DB 40B + 1010	40	φ40	φ42	Bm	10	φ10	φ30	10	20	M4	4	φ16	41.4
S1DB 45B + 1010	45	φ45	φ47	Bm	10	φ10	φ30	10	20	M4	4	φ16	46.1
S1DB 48B + 1010	48	φ48	φ50	Bm	10	φ10	φ30	10	20	M4	4	φ16	49.2
S1DB 50B + 1010	50	φ50	φ52	Bm	10	φ10	φ30	10	20	M4	4	φ16	51.4

【+】にはセットスクリューが付いております。
[+] : Gear with threaded hole / with set screw.

許容伝達動力表 曲げ強さ (W)

Allowable transfer capability table (W) Bending Strength

商品記号 Catalogue Numbers	回転速度 (min ⁻¹) revolution/min						
	10	100	200	400	800	1,200	1,500
S1DB 20B + 1008	1.61	16.08	32.14	64.20	128.08	191.66	239.15
S1DB 24B + 1008	1.93	19.29	38.55	77.00	153.55	229.66	286.46
S1DB 25B + 1008	2.01	20.09	40.16	80.20	159.91	239.15	298.26
S1DB 28B + 1010	2.25	22.50	44.97	89.79	178.97	267.55	333.59
S1DB 30B + 1010	2.41	24.11	48.18	96.18	191.66	286.46	357.10
S1DB 32B + 1010	2.57	25.72	51.38	102.57	204.34	305.33	380.51
S1DB 36B + 1010	2.90	28.93	57.79	115.33	229.66	343.00	426.13
S1DB 40B + 1010	3.22	32.14	64.20	128.08	254.94	380.51	471.31
S1DB 45B + 1010	3.62	36.15	72.20	144.01	286.46	426.13	527.17
S1DB 48B + 1010	3.86	38.55	77.00	153.55	305.33	453.29	560.37
S1DB 50B + 1010	4.02	40.16	80.20	159.91	317.90	471.31	582.37

The above numerical values are Lewis formulas as reference only.
動力の換算式は P26 をご参照ください。
Please refer to the conversion formula of power on page P26.

RoHS 対応

2006年11月生産開始分より欧州 RoHS 指令に対応できる商品を提供しています。
We supplied the KG-products with RoHS compliance of EU to all our valued customers since November 2006

JIS B 1702-1 (ISO) 9~10 級
System of accuracy : JIS B 1702-1(ISO) class 9-10



御注文には必ず “フルネームで商品記号” を明記してください。
Please refer to the catalogue reference while ordering.

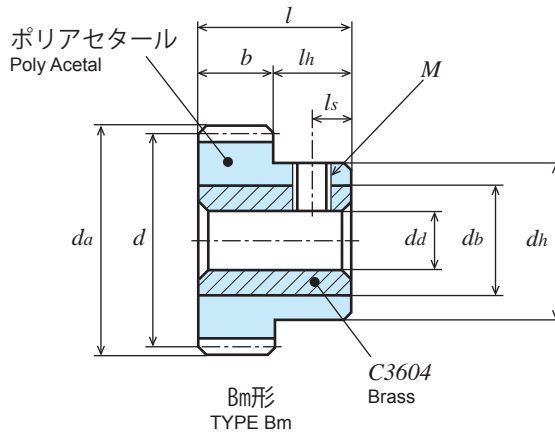

ポリアセタール (白色) 黄銅ブッシュ入り (C3604B)

Material : Poly Acetal (White) with Brass Bushing

単位 : mm
Dimensions : mm

商品記号 Catalogue Number	歯数 Number of Teeth z	基準円直径 Reference Diameter d	歯先円直径 Tip Diameter da	形 Type	歯幅 Face Width b	穴径 Bore Diameter da(H8)	ハブ外径 Hub Diameter dh	ハブ長さ Hub Projection lh	全長 Overall Length l	ねじ Set Screw		ブッシュ外径 Bushing Outer Diameter db	重量 Weight W(g)
										M	ls		
S1DB 56B + 1010	56	φ 56	φ 58	Bm	10	φ10	φ30	10	20	M4	4	φ16	58.5
S1DB 60B + 1010	60	φ 60	φ 62	Bm	10	φ10	φ30	10	20	M4	4	φ16	63.7
S1DB 64B + 1010	64	φ 64	φ 66	Bm	10	φ10	φ30	10	20	M4	4	φ16	69.2
S1DB 70B + 1010	70	φ 70	φ 72	Bm	10	φ10	φ30	10	20	M4	4	φ16	78.2
S1DB 72B + 1010	72	φ 72	φ 74	Bm	10	φ10	φ30	10	20	M4	4	φ16	81.4
S1DB 80B + 1010	80	φ 80	φ 82	Bm	10	φ10	φ30	10	20	M4	4	φ16	94.9
S1DB 90B + 1010	90	φ 90	φ 92	Bm	10	φ10	φ30	10	20	M4	4	φ16	113.9
S1DB 100B + 1010	100	φ100	φ102	Bm	10	φ10	φ30	10	20	M4	4	φ16	135.1
S1DB 120B + 1010	120	φ120	φ122	Bm	10	φ10	φ30	10	20	M4	4	φ16	184.1

【+】にはセットスクリューが付いております。
【+】: Gear with threaded hole / with set screw.

許容伝達動力表 曲げ強さ (W)

Allowable transfer capability table (W) Bending Strength

商品記号 Catalogue Numbers	回転速度 (min ⁻¹) revolution/min						
	10	100	200	400	800	1,200	1,500
S1DB 56B + 1010	4.50	44.97	89.79	178.97	355.53	524.95	647.70
S1DB 60B + 1010	4.83	48.18	96.18	191.66	380.51	560.37	690.72
S1DB 64B + 1010	5.15	51.38	102.57	204.34	404.89	595.51	733.18
S1DB 70B + 1010	5.63	56.19	112.14	223.34	441.23	647.70	793.96
S1DB 72B + 1010	5.79	57.79	115.33	229.66	453.29	664.96	813.91
S1DB 80B + 1010	6.43	64.20	128.08	254.94	501.19	733.18	892.22
S1DB 90B + 1010	7.24	72.20	144.01	286.46	560.37	813.91	986.69
S1DB 100B + 1010	8.04	80.20	159.91	317.90	618.78	892.22	1,073.70
S1DB 108B + 1010	8.68	86.59	172.62	343.00	664.96	953.11	1,136.21
S1DB 112B + 1010	9.01	89.79	178.97	355.53	687.86	982.98	1,166.16
S1DB 120B + 1010	9.65	96.18	191.66	380.51	733.18	1,041.15	1,223.46

The above numerical values are Lewis formulas as reference only.
動力の換算式は P26 をご参照ください。
Please refer to the conversion formula of power on page P26.

RoHS 対応

2006年11月生産開始分より欧州 RoHS 指令に対応できる商品を提供しています。
We supplied the KG-products with RoHS compliance of EU to all our valued customers since November 2006

- 目次 CONTENTS
- インフォメーション INFORMATION
- ギヤボックス GEAR BOXES
- ノーバッキングバックラッシュギヤ ANTI BACKLASH SPUR GEARS
- 歯研研歯車 GROUND SPUR GEARS
- 平歯車 SPUR GEARS
- 内歯車 INTERNAL GEARS
- 歯研ラック GROUND RACKS
- ラック RACKS
- へリカル・スクリューギヤ HELICAL GEARS AND SCREW GEARS
- ウォーム・ウォームホイール WORMS AND WORM WHEELS
- かさ歯車 BEVEL GEARS
- スプロケット SPROCKETS
- 技術資料 REFERENCE DATA

ステンレス平歯車

SPUR GEARS

モジュール
MODULE

1

圧力角 20° (並歯)
20° PRESSURE ANGLE FULL DEPTH TOOTH

JIS B 1702-1 (ISO) 9級
System of accuracy : JIS B 1702-1(ISO) class 9



New **ねじを2箇所 (120°配) にしました。**
締結力が**1.6倍**になりました。
New item with two threaded holes (120°)
Tightening power increased by 1.6 times.

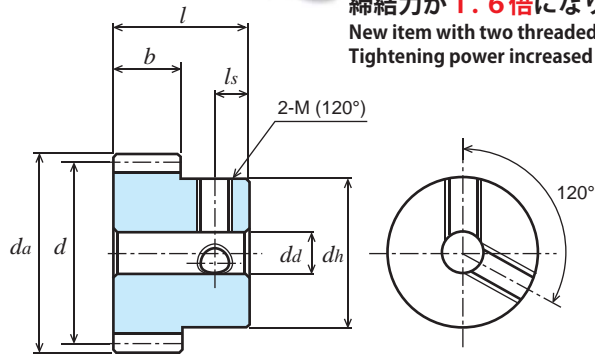

B1形
TYPE B1

SUS304 ステンレス鋼棒 (JIS G 4303)

Material : Stainless Steel SUS304 (JIS G 4303)

単位 : mm
Dimensions : mm

商品記号 Catalogue Number	歯数 Number of Teeth z	基準円直径 Reference Diameter d	歯先円直径 Tip Diameter da	形 Type	歯幅 Face Width b	穴径 Bore Diameter da(H8)	ハブ外径 Hub Diameter dh	ハブ長さ Hub Projection lh	全長 Overall Length l	ねじ Set Screw		重量 Weight W(g)
										2-M(120°)	ls	
S1SU 14K * 0806	14	φ14	φ16	K2	8	φ6	φ16	17	25	2-M4	4	30.4
S1SU 15K * 0806	15	φ15	φ17	K2	8	φ6	φ17	17	25	2-M4	4	35.3
S1SU 16K * 0806	16	φ16	φ18	K2	8	φ6	φ18	17	25	2-M4	4	40.5
S1SU 17B * 0806	17	φ17	φ19	B1	8	φ6	φ14	8	16	2-M4	4	19.9
S1SU 18B * 0806	18	φ18	φ20	B1	8	φ6	φ14	8	16	2-M4	4	21.7
S1SU 18B * 1006	18	φ18	φ20	B1	10	φ6	φ14	10	20	2-M4	4	27.2
S1SU 20B * 0806	20	φ20	φ22	B1	8	φ6	φ16	8	16	2-M4	4	28.3
S1SU 20B * 1006	20	φ20	φ22	B1	10	φ6	φ16	10	20	2-M4	4	35.5
S1SU 21B * 0806	21	φ21	φ23	B1	8	φ6	φ18	8	16	2-M4	4	33.5
S1SU 22B * 0806	22	φ22	φ24	B1	8	φ6	φ18	8	16	2-M4	4	35.7
S1SU 24B * 0806	24	φ24	φ26	B1	8	φ6	φ18	8	16	2-M4	4	40.3
S1SU 24B * 1006	24	φ24	φ26	B1	10	φ6	φ18	10	20	2-M4	4	50.6
S1SU 25B * 0806	25	φ25	φ27	B1	8	φ6	φ18	8	16	2-M4	4	42.7
S1SU 25B * 1006	25	φ25	φ27	B1	10	φ6	φ20	10	20	2-M4	4	58.2
S1SU 26B * 0806	26	φ26	φ28	B1	8	φ6	φ20	8	16	2-M4	4	48.9

SUS304 の商品にはセットスクリューは付いておりません。[*] : Gear with two threaded holes / without set screw.

許容伝達動力表 曲げ強さ (W)

Allowable transfer capability table (W) Bending Strength

商品記号 Catalogue Numbers	回転速度 (min ⁻¹) revolution/min						
	10	100	200	400	800	1,200	1,500
S1SU 14K * 0806	1.77	17.71	35.41	70.82	141.64	212.46	261.67
S1SU 15K * 0806	1.98	19.84	39.68	79.37	158.73	238.10	289.88
S1SU 16K * 0806	2.20	22.02	44.04	88.08	176.16	264.03	318.05
S1SU 17B * 0806	2.42	24.23	48.46	96.92	193.84	287.82	346.06
S1SU 18B * 0806	2.65	26.47	52.94	105.88	211.76	311.52	373.85
S1SU 18B * 1006	3.31	33.09	66.18	132.35	264.70	389.40	467.32
S1SU 20B * 0806	3.11	31.08	62.16	124.32	248.64	359.14	429.43
S1SU 20B * 1006	3.89	38.85	77.70	155.40	310.80	448.92	536.79
S1SU 21B * 0806	3.34	33.40	66.81	133.62	267.24	382.52	456.60
S1SU 22B * 0806	3.58	35.76	71.52	143.04	286.09	405.86	483.62
S1SU 24B * 0806	4.05	40.52	81.04	162.07	323.88	451.79	536.54
S1SU 24B * 1006	5.06	50.65	101.29	202.59	404.85	564.74	670.68
S1SU 25B * 0806	4.29	42.93	85.86	171.72	341.02	474.52	562.62
S1SU 25B * 1006	5.37	53.66	107.32	214.65	426.27	593.15	703.28
S1SU 26B * 0806	4.54	45.36	90.71	181.43	358.07	497.04	588.38

The above numerical values are equivalent to JGMA formulas as reference only.

動力の換算式は P26 をご参照ください。

Please refer to the conversion formula of power on page P26.

ステンレス平歯車

SPUR GEARS

モジュール
MODULE

1

圧力角 20° (並歯)
20° PRESSURE ANGLE FULL DEPTH TOOTH

JIS B 1702-1 (ISO) 9 級
System of accuracy : JIS B 1702-1(ISO) class 9



御注文には必ず “フルネームで商品記号” を明記してください。
Please refer to the catalogue reference while ordering.

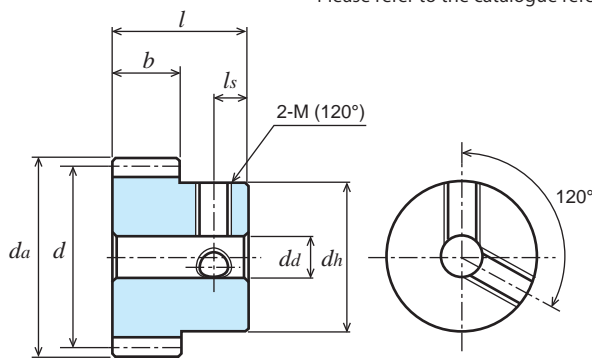

B1形
TYPE B1

SUS304 ステンレス鋼棒 (JIS G 4303)

Material : Stainless Steel SUS304 (JIS G 4303)

単位 : mm
Dimensions : mm

商品記号 Catalogue Number	歯数 Number of Teeth z	基準円直径 Reference Diameter d	歯先円直径 Tip Diameter da	形 Type	歯幅 Face Width b	穴径 Bore Diameter da(H8)	ハブ外径 Hub Diameter dh	ハブ長さ Hub Projection lh	全長 Overall Length l	ねじ Set Screw		重量 Weight W(g)
										2-M(120°)	ls	
S1SU 28B * 0806	28	φ28	φ30	B1	8	φ6	φ20	8	16	2-M4	4	54.2
S1SU 28B * 1006	28	φ28	φ30	B1	10	φ6	φ20	10	20	2-M4	4	68.1
S1SU 30B * 0806	30	φ30	φ32	B1	8	φ6	φ24	8	16	2-M4	4	68.5
S1SU 30B * 0806	30	φ30	φ32	B1	8	φ6	φ24	8	16	2-M4	4	68.5
S1SU 30B * 1006	30	φ30	φ32	B1	10	φ6	φ24	10	20	2-M4	4	86.0
S1SU 32B * 0606	32	φ32	φ34	B1	6	φ6	φ24	10	16	2-M4	4	69.1
S1SU 34B * 0606	34	φ34	φ36	B1	6	φ6	φ24	10	16	2-M4	4	74.0
S1SU 35B * 0606	35	φ35	φ37	B1	6	φ6	φ24	10	16	2-M4	4	76.6
S1SU 36B * 0608	36	φ36	φ38	B1	6	φ8	φ24	10	16	2-M4	4	76.6
S1SU 40B * 0608	40	φ40	φ42	B1	6	φ8	φ28	10	16	2-M4	4	100.6
S1SU 42B * 0608	42	φ42	φ44	B1	6	φ8	φ28	10	16	2-M4	4	106.7
S1SU 44B * 0608	44	φ44	φ46	B1	6	φ8	φ28	10	16	2-M4	4	113.1
S1SU 45B * 0608	45	φ45	φ47	B1	6	φ8	φ28	10	16	2-M4	4	116.5
S1SU 48B * 0608	48	φ48	φ50	B1	6	φ8	φ28	10	16	2-M4	4	126.9
S1SU 50B * 0608	50	φ50	φ52	B1	6	φ8	φ28	10	16	2-M4	4	134.2

SUS304 の商品にはセットスクリューは付いておりません。

[*] : Gear with two threaded holes / without set screw.

許容伝達動力表 曲げ強さ (W)

Allowable transfer capability table (W) Bending Strength

商品記号 Catalogue Numbers	回転速度 (min ⁻¹) revolution/min						
	10	100	200	400	800	1,200	1,500
S1SU 28B * 0806	5.03	50.26	100.52	201.03	391.90	541.43	638.95
S1SU 28B * 1006	6.28	62.82	125.65	251.29	489.88	676.79	798.68
S1SU 30B * 0806	5.52	55.18	110.37	220.74	425.11	584.61	687.84
S1SU 30B * 1006	6.90	68.98	137.96	275.92	531.39	730.76	859.80
S1SU 32B * 0606	4.51	45.13	90.27	180.53	343.53	470.31	551.76
S1SU 34B * 0606	4.89	48.91	97.82	195.64	367.87	501.44	586.65
S1SU 35B * 0606	5.08	50.81	101.61	203.23	379.90	516.74	603.73
S1SU 36B * 0608	5.27	52.71	105.42	210.85	391.84	531.86	620.57
S1SU 40B * 0608	6.04	60.39	120.78	241.55	438.65	590.59	693.00
S1SU 42B * 0608	6.43	64.26	128.51	257.02	461.49	618.92	733.00
S1SU 44B * 0608	6.81	68.10	136.19	272.39	483.61	646.13	772.19
S1SU 45B * 0608	7.00	70.04	140.08	280.17	494.67	659.68	791.90
S1SU 48B * 0608	7.59	75.90	151.80	303.36	527.27	700.19	850.59
S1SU 50B * 0608	7.98	79.82	159.65	317.05	548.54	732.84	889.33

The above numerical values are equivalent to JGMA formulas as reference only.

動力の換算式は P26 をご参照ください。

Please refer to the conversion formula of power on page P26.

目次
CONTENTS

インフォメーション
INFORMATION

ギヤボックス
GEAR BOXES

ノーバッキングギヤ
ANTI BACKLASH SPUR GEARS

歯研削歯車
GROUND SPUR GEARS

歯研削歯車
SPUR GEARS

内歯車
INTERNAL GEARS

歯研削ラック
GROUND RACKS

ラック
RACKS

（リ）カ・ス・コ・ニ・コ・キ
HELICAL GEARS AND SCREW GEARS

ワーム・マ・ニ・コ・キ
WORMS AND WORM WHEELS

かさ歯車
BEVEL GEARS

スプロケット
SPROCKETS

技術資料
REFERENCE DATA

ステンレス平歯車

SPUR GEARS

モジュール
MODULE

1

圧力角 20° (並歯)
20° PRESSURE ANGLE FULL DEPTH TOOTH

JIS B 1702-1 (ISO) 9 級
System of accuracy : JIS B 1702-1(ISO) class 9



New **ねじを2箇所 (120°配) にしました。**
締結力が **1.6倍** になりました。
New item with two threaded holes (120°)
Tightening power increased by 1.6 times.

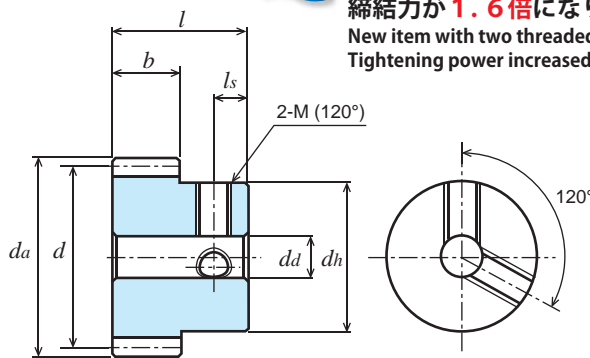

B1形
TYPE B1

SUS304 ステンレス鋼棒 (JIS G 4303)

Material : Stainless Steel SUS304 (JIS G 4303)

単位 : mm
Dimensions : mm

商品記号 Catalogue Number	歯数 Number of Teeth z	基準円直径 Reference Diameter d	歯先円直径 Tip Diameter da	形 Type	歯幅 Face Width b	穴径 Bore Diameter da(H8)	ハブ外径 Hub Diameter dh	ハブ長さ Hub Projection lh	全長 Overall Length l	ねじ Set Screw		重量 Weight W(g)
										2-M(120°)	ls	
S1SU 52B * 0608	52	φ 52	φ 54	B1	6	φ 8	φ28	10	16	2-M5	5	140.9
S1SU 54B * 0608	54	φ 54	φ 56	B1	6	φ 8	φ28	10	16	2-M5	5	148.8
S1SU 56B * 0610	56	φ 56	φ 58	B1	6	φ 10	φ30	10	16	2-M5	5	160.6
S1SU 60B * 0610	60	φ 60	φ 62	B1	6	φ 10	φ30	10	16	2-M5	5	178.0
S1SU 64B * 0610	64	φ 64	φ 66	B1	6	φ 10	φ30	10	16	2-M5	5	196.5
S1SU 70B * 0610	70	φ 70	φ 72	B1	6	φ 10	φ30	10	16	2-M5	5	226.6
S1SU 72B * 0610	72	φ 72	φ 74	B1	6	φ 10	φ30	10	16	2-M5	5	237.2
S1SU 80B * 0610	80	φ 80	φ 82	B1	6	φ 10	φ30	10	16	2-M5	5	282.6
S1SU 90B * 0610	90	φ 90	φ 92	B1	6	φ 10	φ30	10	16	2-M5	5	346.1
S1SU 100B * 0610	100	φ 100	φ 102	B1	6	φ 10	φ30	10	16	2-M5	5	417.1
S1SU 120B * 0610	120	φ 120	φ 122	B1	6	φ 10	φ30	10	16	2-M5	5	581.6

SUS304の商品にはセットスクリューは付いておりません。

[*] : Gear with two threaded holes / without set screw.

許容伝達動力表 曲げ強さ (W)

Allowable transfer capability table (W) Bending Strength

商品記号 Catalogue Numbers	回転速度 (min ⁻¹) revolution/min						
	10	100	200	400	800	1,200	1,500
S1SU 52B * 0608	8.38	83.76	167.51	330.61	569.42	765.27	927.74
S1SU 54B * 0608	8.77	87.70	175.40	344.05	589.94	797.50	965.84
S1SU 56B * 0610	9.17	91.66	183.32	357.37	610.11	829.53	1,003.62
S1SU 60B * 0610	9.96	99.60	199.19	383.62	649.37	892.91	1,078.17
S1SU 64B * 0610	10.76	107.57	215.14	409.37	687.26	955.40	1,151.78
S1SU 70B * 0610	11.96	119.58	239.15	447.06	741.67	1,047.46	1,266.18
S1SU 72B * 0610	12.36	123.59	247.19	459.37	760.11	1,077.69	1,303.88
S1SU 80B * 0610	13.97	139.71	279.42	507.42	848.29	1,196.75	1,452.49
S1SU 90B * 0610	15.98	159.75	319.50	564.12	954.81	1,348.27	1,631.26
S1SU 100B * 0610	18.00	180.02	357.51	618.54	1,059.38	1,497.28	1,806.04
S1SU 120B * 0610	22.07	220.74	425.12	719.62	1,260.58	1,784.16	2,207.42

The above numerical values are equivalent to JGMA formulas as reference only.

動力の換算式は P26 をご参照ください。

Please refer to the conversion formula of power on page P26.

Memo

目次
CONTENTS

インフォメーション
INFORMATION

ギヤボックス
GEAR BOXES

ノーバッキングギヤ
ANTI BACKLASH SPUR GEARS

歯研平歯車
GROUND SPUR GEARS

平歯車
SPUR GEARS

内歯車
INTERNAL GEARS

歯研ラック
GROUND RACKS

ラック
RACKS

へりかき・スクリューギヤ
HELICAL GEARS AND SCREW GEARS

ワーム・ワームホイール
WORMS AND WORM WHEELS

かさ歯車
BEVEL GEARS

スプロケット
SPROCKETS

技術資料
REFERENCE DATA

平歯車 SPUR GEARS

モジュール
MODULE

1

圧力角 20° (並歯) 歯数 8 ~ 14

20° PRESSURE ANGLE FULL DEPTH TOOTH Z 8 to Z 14

JIS B 1702-1 (ISO) 8 ~ 9 級
System of accuracy : JIS B 1702-1(ISO) class 8-9



New

ねじを2箇所 (120°配) にしました。
New item with two threaded holes (120°)

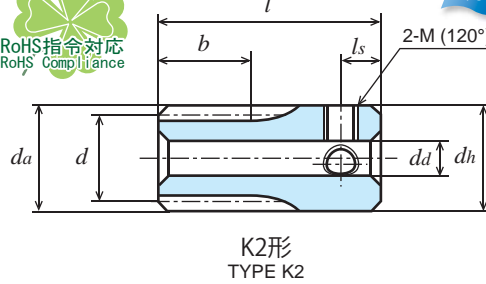

K2形
TYPE K2

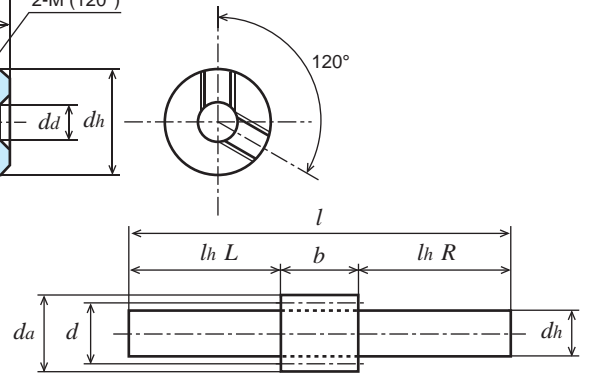

L1形
TYPE L1

S45C 機械構造用炭素鋼 (JIS G 4051) *印を付した商品は転位歯車です。転位係数 x は 0.5 です。
Material : Carbon Steel (ISO C45) * mark has been profile shifted gears. (Rack shift coefficient x = 0.5)

単位 : mm
Dimensions : mm

商品記号 Catalogue Number	歯数 Number of Teeth z	基準円直径 Reference Diameter d	歯先円直径 Tip Diameter da	形 Type	歯幅 Face Width b	穴径 Bore Diameter dd(H7)	ハブ外径 Hub Diameter dh	ハブ長さ Hub Projection lh	全長 Overall Length l	キミぞ Key Way b ₂ × t ₂	ねじ Set Screw		重量 Weight W(g)
											2-M(120°)	ls	
S1S 8L - 1206	8	*	φ10.64	L1	12	-	φ 6 (h9)	L16 R32	60	-	-	-	16.7
S1S 8L - 1210F	8	*	φ10.64	L2	12	-	φ10.64	L16 R32	60	-	-	-	39.5
S1S 10L - 1208	10	*	φ12.66	L1	12	-	φ 8 (h9)	L16 R32	60	-	-	-	27.9
S1S 10L - 1212F	10	*	φ12.66	L2	12	-	φ12.66	L16 R32	60	-	-	-	56.4
S1S 12K * 1206	12		φ12	K2	12	φ6(H8)	φ14	18	30	-	2-M4	5	25.1
S1S 13K * 1206	13		φ13	K2	12	φ6(H8)	φ15	18	30	-	2-M4	5	30.1
S1S 14A - 0805F	14		φ14	A1	8	φ5	-	-	8	-	-	-	8.4
S1S 14A - 0806	14		φ14	A1	8	φ6	-	-	8	-	-	-	7.9
S1S 14A - 1206	14		φ14	A1	12	φ6	-	-	12	-	-	-	11.8
S1S 14B - 0805	14		φ14	B1	8	φ5(H8)	φ11	8	16	-	-	-	13.0
S1S 14B - 1005	14		φ14	B1	10	φ5(H8)	φ11	10	20	-	-	-	16.47
S1S 14B - 1005H	14		φ14	B1	10	φ5(H※)	φ11	10	20	-	-	-	16.47
S1S 14K * 0806	14		φ14	K2	8	φ6(H8)	φ16	17	25	-	2-M4	4	30.1
S1S 14K * 1206	14		φ14	K2	12	φ6(H8)	φ16	18	30	-	2-M5	5	35.0

【*】(アスタ)にはセットスクリーが2個付いております。[*]: Gear with two threaded holes / with two set screws.

カタログ記号の末尾に【H】を付した商品は歯部高周波焼入済です。Gear tooth surface completed with induction hardening, Hardness HRC47 to 53.

※ 歯部高周波焼入後の穴修正は行っていません。Bore correcting after induction hardening is not completed.

追加加工の際は、追加加工時の注意をご参照ください。Please refer to Precaution for additional process when additional process.

許容伝達動力表 曲げ強さ (W)

Allowable transfer capability table (W) Bending Strength

歯数 z	歯幅 b	焼入 H	回転速度 (min ⁻¹) revolution/min						
			10	100	200	400	800	1,200	1,500
8	12	-	3.21	32.15	64.29	128.58	257.16	385.74	482.18
10	12	-	4.43	44.29	88.59	177.17	354.34	531.52	664.40
12	12	-	4.07	40.75	81.49	162.99	325.97	488.96	611.20
13	12	-	4.68	46.85	93.69	187.38	374.77	562.15	700.48
14	8	-	3.54	35.41	70.82	141.64	283.28	424.92	523.34
14	10	-	3.98	39.79	79.58	159.17	318.34	477.50	596.88
14	10	○	4.71	47.12	94.24	188.49	376.98	565.46	706.83
14	12	-	5.31	53.12	106.23	212.46	424.92	637.38	785.01

KG 規格は“並幅”(軽荷重用)と“広幅”(重荷重用)があります。ご用途に応じてお選び下さい。
動力の換算式は P26 をご参照ください。Please refer to the conversion formula of power on page P26.

許容伝達動力表 歯面強さ (W)

Allowable transfer capability table (W) Surface Durability

回転速度 (min ⁻¹) revolution/min							
10	100	200	400	800	1,200	1,500	
-	-	-	-	-	-	-	
-	-	-	-	-	-	-	
-	-	-	-	-	-	-	
-	-	-	-	-	-	-	
0.14	1.36	2.72	5.45	10.89	16.34	20.42	
0.71	7.91	16.34	33.51	67.02	100.53	125.66	
-	-	-	-	-	-	-	

平歯車

SPUR GEARS

モジュール
MODULE

1

圧力角 20° (並歯) 歯数 15 ~ 16
20° PRESSURE ANGLE FULL DEPTH TOOTH Z 15 to Z 16

JIS B 1702-1 (ISO) 8 ~ 9 級
System of accuracy : JIS B 1702-1(ISO) class 8-9



御注文には必ず “フルネームで商品記号” を明記してください。
Please refer to the catalogue reference while ordering.

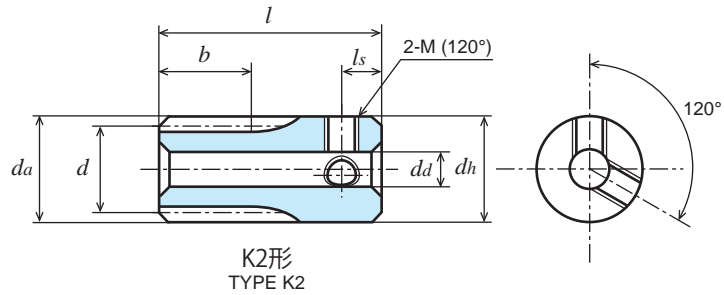

S45C 機械構造用炭素鋼 (JIS G 4051)

Material : Carbon Steel (ISO C45)

単位 : mm
Dimensions : mm

商品記号 Catalogue Number	歯数 Number of Teeth z	基準円直径 Reference Diameter d	歯先円直径 Tip Diameter da	形 Type	歯幅 Face Width b	穴径 Bore Diameter dd(H7)	ハブ外径 Hub Diameter dh	ハブ長さ Hub Projection lh	全長 Overall Length l	キ み ぞ Key Way b ₂ × t ₂	ねじ Set Screw		重量 Weight W(g)
											2-M(120°)	ls	
S1S 15A - 0805F	15	φ15	φ17	A1	8	φ5	-	-	8	-	-	-	9.9
S1S 15A - 0806	15	φ15	φ17	A1	8	φ6	-	-	8	-	-	-	9.3
S1S 15A - 1206	15	φ15	φ17	A1	12	φ6	-	-	12	-	-	-	14.0
S1S 15B - 0805	15	φ15	φ17	B1	8	φ5(H8)	φ12	8	16	-	-	-	15.7
S1S 15B - 1005	15	φ15	φ17	B1	10	φ5(H8)	φ12	10	20	-	-	-	19.68
S1S 15B - 1005H	15	φ15	φ17	B1	10	φ5(H※)	φ12	10	20	-	-	-	19.68
S1S 15K * 0806	15	φ15	φ17	K2	8	φ6(H8)	φ17	17	25	-	2-M4	4	35.0
S1S 15K * 1206	15	φ15	φ17	K2	12	φ6(H8)	φ17	18	30	-	2-M5	5	40.7
S1S 16A - 0805F	16	φ16	φ18	A1	8	φ5	-	-	8	-	-	-	11.4
S1S 16A - 0806	16	φ16	φ18	A1	8	φ6	-	-	8	-	-	-	10.9
S1S 16A - 1208	16	φ16	φ18	A1	12	φ8	-	-	12	-	-	-	14.2
S1S 16B - 0805	16	φ16	φ18	B1	8	φ5(H8)	φ13	8	16	-	-	-	18.5
S1S 16B - 1005	16	φ16	φ18	B1	10	φ5(H8)	φ13	10	20	-	-	-	23.13
S1S 16B - 1005H	16	φ16	φ18	B1	10	φ5(H※)	φ13	10	20	-	-	-	23.13
S1S 16K * 0806	16	φ16	φ18	K2	8	φ6(H8)	φ18	17	25	-	2-M4	4	40.0
S1S 16K * 0808	16	φ16	φ18	K2	8	φ8(H8)	φ18	17	25	-	2-M4	4	35.9
S1S 16K * 1208	16	φ16	φ18	K2	12	φ8(H8)	φ18	18	30	-	2-M5	5	41.8

【*】(アスタ)にはセットスクリューが2個付いております。【*】: Gear with two threaded holes / with two set screws.

カタログ記号の末尾に【H】を付した商品は歯部高周波焼入済です。Gear tooth surface completed with induction hardening, Hardness HRC47 to 53.
※

歯部高周波焼入後の穴修正は行っていません。Bore correcting after induction hardening is not completed.

追加加工の際は、追加加工時の注意をご参照ください。Please refer to Precaution for additional process when additional process.

許容伝達動力表 曲げ強さ (W)

Allowable transfer capability table (W) Bending Strength

歯数 z	歯幅 b	焼入 H	回転速度 (min ⁻¹) revolution/min						
			10	100	200	400	800	1,200	1,500
15	8	-	3.97	39.68	79.37	158.73	317.47	476.20	579.76
15	10	-	4.50	45.03	90.06	180.11	360.22	540.33	675.41
15	10	○	5.34	53.41	106.81	213.62	427.24	640.86	801.07
15	12	-	5.95	59.53	119.05	238.10	476.20	714.30	869.64
16	8	-	4.40	44.04	88.08	176.16	352.32	528.05	636.11
16	10	-	5.03	50.26	100.53	201.05	402.11	603.16	753.95
16	10	○	5.92	59.16	118.33	236.66	473.31	709.97	887.46
16	12	-	6.61	66.06	132.12	264.24	528.48	792.08	954.16

The above numerical values are equivalent to JGMA formulas as reference only.

動力の換算式は P26 をご参照ください。Please refer to the conversion formula of power on page P26.

許容伝達動力表 歯面強さ (W)

Allowable transfer capability table (W) Surface Durability

回転速度 (min ⁻¹) revolution/min							
10	100	200	400	800	1,200	1,500	
-	-	-	-	-	-	-	
0.16	1.57	3.14	6.28	12.57	20.11	23.56	
0.83	9.11	18.85	38.54	79.58	119.38	149.22	
-	-	-	-	-	-	-	
-	-	-	-	-	-	-	
0.19	1.88	3.77	7.54	15.08	22.62	28.27	
0.94	10.47	20.94	41.89	90.47	135.71	169.64	
-	-	-	-	-	-	-	

目次
CONTENTS

インフォメーション
INFORMATION

ギヤボックス
GEAR BOXES

ノーバッキングギヤ
ANTI BACKLASH SPUR GEAR

歯研削歯車
GROUND SPUR GEARS

歯研削歯車
SPUR GEARS

内歯車
INTERNAL GEARS

歯研削ラック
GROUND RACKS

ラック
RACKS

ハニカムギヤ
HEXAGONAL GEAR AND SCREW GEAR

ワーム
WORMS AND WORM WHEELS

かさ歯車
BEVEL GEARS

スプロケット
SPROCKETS

技術資料
REFERENCE DATA

平歯車 SPUR GEARS

モジュール
MODULE

1

圧力角 20° (並歯) 歯数 17 18
20° PRESSURE ANGLE FULL DEPTH TOOTH Z 17 to Z 18

JIS B 1702-1 (ISO) 8 ~ 9 級
System of accuracy : JIS B 1702-1(ISO) class 8-9



御注文には必ず “フルネームで商品記号” を明記してください。
Please refer to the catalogue reference while ordering.

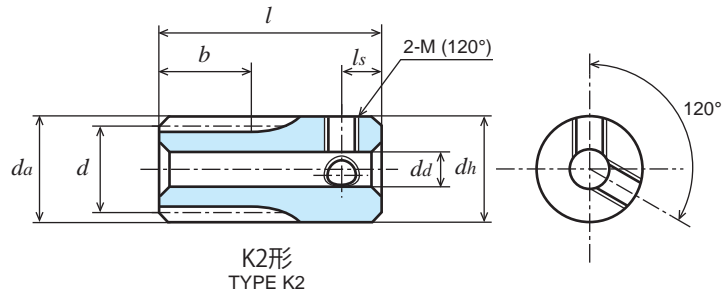

K2形
TYPE K2

S45C 機械構造用炭素鋼 (JIS G 4051) Material : Carbon Steel (ISO C45)

単位 : mm
Dimensions : mm

商品記号 Catalogue Number	歯数 Number of Teeth z	基準円直径 Reference Diameter d	歯先円直径 Tip Diameter da	形 Type	歯幅 Face Width b	穴径 Bore Diameter dd(H7)	ハブ外径 Hub Diameter dh	ハブ長さ Hub Projection lh	全長 Overall Length l	キ み ぞ Key Way b ₂ × t ₂	ねじ Set Screw		重量 Weight W(g)
											2-M(120°)	ls	
S1S 17A - 0805F	17	φ17	φ19	A1	8	φ5	-	-	8	-	-	-	13.0
S1S 17A - 1208F	17	φ17	φ19	A1	12	φ8	-	-	12	-	-	-	16.7
S1S 17B - 0805	17	φ17	φ19	B1	8	φ5(H8)	φ14	8	16	-	-	-	21.5
S1S 17B - 1005	17	φ17	φ19	B1	10	φ5(H8)	φ14	10	20	-	-	-	26.84
S1S 17B - 1005H	17	φ17	φ19	B1	10	φ5(H※)	φ14	10	20	-	-	-	26.84
S1S 17K * 0808	17	φ17	φ19	K2	8	φ8(H8)	φ19	17	25	-	2-M4	4	41.3
S1S 17K * 1208	17	φ17	φ19	K2	12	φ8(H8)	φ19	18	30	-	2-M5	5	48.2
S1S 18A - 0805F	18	φ18	φ20	A1	8	φ5	-	-	8	-	-	-	14.8
S1S 18A - 0806	18	φ18	φ20	A1	8	φ6	-	-	8	-	-	-	14.2
S1S 18A - 1208	18	φ18	φ20	A1	12	φ8	-	-	12	-	-	-	19.2
S1S 18B * 0806	18	φ18	φ20	B1	8	φ6	φ14	8	16	-	2-M4	4	21.5
S1S 18B - 1006	18	φ18	φ20	B1	10	φ6(H8)	φ15	10	20	-	-	-	29.43
S1S 18B - 1006H	18	φ18	φ20	B1	10	φ6(H※)	φ15	10	20	-	-	-	29.43
S1S 18B * 1008	18	φ18	φ20	B1	10	φ8	φ15	10	20	-	2-M5	5	25.1
S1S 18K * 0808	18	φ18	φ20	K2	8	φ8(H8)	φ20	17	25	-	2-M4	4	47.1
S1S 18K * 1208	18	φ18	φ20	K2	12	φ8(H8)	φ20	18	30	-	2-M4	4	55.6

【*】(アスタ)にはセットスクリューが2個付いております。[*]: Gear with two threaded holes / with two set screws.

カタログ記号の末尾に【H】を付した商品は歯部高周波焼入済です。Gear tooth surface completed with induction hardening, Hardness HRC47 to 53.

※
歯部高周波焼入後の穴修正は行っていません。Bore correcting after induction hardening is not completed.

追加加工の際は、追加加工時の注意をご参照ください。Please refer to Precaution for additional process when additional process.

許容伝達動力表 曲げ強さ (W)

Allowable transfer capability table (W) Bending Strength

歯数 z	歯幅 b	焼入 H	回転速度 (min ⁻¹) revolution/min						
			10	100	200	400	800	1,200	1,500
17	8	-	4.85	48.46	96.92	193.84	387.68	575.64	692.11
17	10	-	5.48	54.77	109.53	219.06	438.13	657.19	821.49
17	10	○	6.42	64.19	128.38	256.76	513.52	770.29	962.86
17	12	-	7.27	72.69	145.38	290.76	581.53	863.46	1,038.17
18	8	-	5.29	52.94	105.88	211.76	423.52	635.29	774.71
18	10	-	6.62	66.18	132.35	264.7	529.41	794.11	984.63
18	10	○	6.93	69.32	138.64	277.29	554.57	831.86	1,039.82
18	12	-	7.94	79.41	158.82	317.64	635.29	952.94	1,171.56

The above numerical values are equivalent to JGMA formulas as reference only.

動力の換算式はP26をご参照ください。Please refer to the conversion formula of power on page P26.

許容伝達動力表 歯面強さ (W)

Allowable transfer capability table (W) Surface Durability

回転速度 (min ⁻¹) revolution/min						
10	100	200	400	800	1,200	1,500
-	-	-	-	-	-	-
0.20	1.99	4.19	8.38	16.75	25.13	29.84
1.05	11.52	23.04	50.26	100.53	150.79	188.49
-	-	-	-	-	-	-
0.26	2.62	5.24	10.47	20.94	31.41	39.27
1.20	13.09	27.23	54.45	108.90	163.36	204.20
-	-	-	-	-	-	-

平歯車

SPUR GEARS

モジュール
MODULE

1

圧力角 20° (並歯) 歯数 19 20

20° PRESSURE ANGLE FULL DEPTH TOOTH Z 19 to Z 20

JIS B 1702-1 (ISO) 8級 (高周波焼入品: 9級)
System of accuracy: JIS B 1702-1(ISO) class 8
(Induction hardened products: class 9)



New **ねじを2箇所 (120°配) にしました。**
締結力が1.6倍になりました。
New item with two threaded holes (120°)
Tightening power increased by 1.6 times.

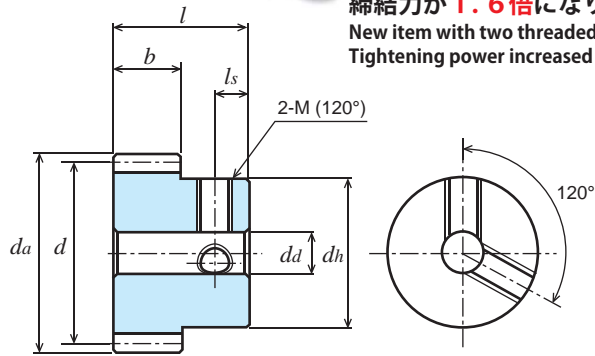

B1形
TYPE B1

S45C 機械構造用炭素鋼 (JIS G 4051)

Material: Carbon Steel (ISO C45)

単位: mm
Dimensions: mm

商品記号 Catalogue Number	歯数 Number of Teeth z	基準円直径 Reference Diameter d	歯先円直径 Tip Diameter da	形 Type	歯幅 Face Width b	穴径 Bore Diameter da(H7)	ハブ外径 Hub Diameter dh	ハブ長さ Hub Projection lh	全長 Overall Length l	キミぞ Key Way b ₂ × t ₂	ねじ Set Screw		重量 Weight W(g)
											2-M(120°)	ls	
S1S 19A - 0806F	19	φ19	φ21	A1	8	φ6	-	-	8	-	-	-	16.0
S1S 19A - 1208F	19	φ19	φ21	A1	12	φ8	-	-	12	-	-	-	22.0
S1S 19B - 0806F	19	φ19	φ21	B1	8	φ6	φ16	8	16	-	-	-	26.9
S1S 19B - 1208F	19	φ19	φ21	B1	12	φ8	φ16	8	20	-	-	-	31.4
S1S 20A - 0806F	20	φ20	φ22	A1	8	φ6	-	-	8	-	-	-	18.0
S1S 20A - 0808	20	φ20	φ22	A1	8	φ8	-	-	8	-	-	-	15.0
S1S 20A - 1208F	20	φ20	φ22	A1	12	φ8	-	-	12	-	-	-	24.9
S1S 20A = 1210	20	φ20	φ22	A1	12	φ10	-	-	12	3 × 1.4	-	-	19.2
S1S 20B - 0806F	20	φ20	φ22	B1	8	φ6	φ16	8	16	-	-	-	28.8
S1S 20B * 0806	20	φ20	φ22	B1	8	φ6	φ16	8	16	-	2-M4	4	28.0
S1S 20B * 0808	20	φ20	φ22	B1	8	φ8	φ16	8	16	-	2-M4	4	25.4
● S1S 20B - 1005	20	φ20	φ22	B1	10	φ5(H8)	φ16	10	20	-	-	-	37.0
● S1S 20B - 1005H	20	φ20	φ22	B1	10	φ5(H※)	φ16	10	20	-	-	-	37.0
● S1S 20B - 1006	20	φ20	φ22	B1	10	φ6(H8)	φ16	10	20	-	-	-	36.03
S1S 20B * 1008	20	φ20	φ22	B1	10	φ8	φ16	10	20	-	2-M5	5	31.5
S1S 20B - 1206F	20	φ20	φ22	B1	12	φ6	φ16	8	20	-	-	-	37.8
S1S 20B * 1206	20	φ20	φ22	B1	12	φ6	φ16	8	20	-	2-M4	4	37.0
S1S 20B * 1208	20	φ20	φ22	B1	12	φ8	φ16	8	20	-	2-M4	4	33.7

●の商品は新商品です。Products with ● marks are new item.

【=】(イコール)にはキー材が付いております。 [=]: Gear with key way / with key.

【*】(アスタ)にはセットスクリューが2個付いております。 [*]: Gear with two threaded holes / with two set screws.

カタログ記号の末尾に【H】を付した商品は歯部高周波焼入済です。Gear tooth surface completed with induction hardening, Hardness HRC47 to 53.

※

歯部高周波焼入後の穴修正は行っていません。Bore correcting after induction hardening is not completed.

追加加工の際は、追加加工時の注意をご参照ください。Please refer to Precaution for additional process when additional process.

許容伝達動力表 曲げ強さ (W)

Allowable transfer capability table (W) Bending Strength

歯数 z	歯幅 b	焼入 H	回転速度 (min ⁻¹) revolution/min						
			10	100	200	400	800	1,200	1,500
19	8	-	6.68	66.81	133.62	267.24	534.47	765.05	913.19
19	12	-	10.02	100.21	200.43	400.86	801.71	1,147.57	1,369.79
20	8	-	6.22	62.16	124.32	248.64	497.28	718.27	858.87
20	10	-	7.82	78.22	156.44	312.89	625.78	904.74	1,080.66
20	10	○	8.30	82.97	165.95	331.90	663.80	962.04	1,154.75
20	12	-	9.32	93.24	186.48	372.96	745.92	1,077.41	1,288.30

The above references are JGMA standard.

動力の換算式は P26 をご参照ください。Please refer to the conversion formula of power on page P26.

許容伝達動力表 歯面強さ (W)

Allowable transfer capability table (W) Surface Durability

回転速度 (min ⁻¹) revolution/min							
10	100	200	400	800	1,200	1,500	
-	-	-	-	-	-	-	
-	-	-	-	-	-	-	
-	-	-	-	-	-	-	
0.32	3.25	6.49	12.98	25.97	38.95	45.55	
1.45	16.05	33.11	68.24	140.74	207.61	251.67	
-	-	-	-	-	-	-	

目次
CONTENTS

インフォメーション
INFORMATION

ギヤボックス
GEAR BOXES

ノーバッキングバックラッシュギヤ
ANTI BACKLASH SPUR GEARS

歯研削歯車
GROUND SPUR GEARS

平歯車
SPUR GEARS

内歯車
INTERNAL GEARS

歯研削ラック
GROUND RACKS

ラック
RACKS

傾斜歯車とスクリューギヤ
HELICAL GEARS AND SCREW GEARS

ワームとワームホイール
WORMS AND WORM WHEELS

かさ歯車
BEVEL GEARS

スプロケット
SPROCKETS

技術資料
REFERENCE DATA

平歯車 SPUR GEARS

モジュール
MODULE

1

圧力角 20° (並歯) 歯数 21 ~ 23
20° PRESSURE ANGLE FULL DEPTH TOOTH Z 21 to Z 23

JIS B 1702-1 (ISO) 8 級
System of accuracy : JIS B 1702-1(ISO) class 8



御注文には必ず“フルネームで商品記号”を明記してください。
Please refer to the catalogue reference while ordering.

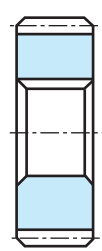

A1形
TYPE A1

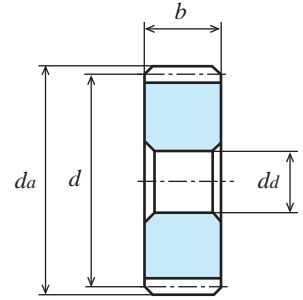
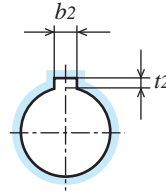

A1形
TYPE A1

S45C 機械構造用炭素鋼 (JIS G 4051) Material : Carbon Steel (ISO C45)

単位 : mm
Dimensions : mm

商品記号 Catalogue Number	歯数 Number of Teeth z	基準円直径 Reference Diameter d	歯先円直径 Tip Diameter da	形 Type	歯幅 Face Width b	穴径 Bore Diameter da(H7)	ハブ外径 Hub Diameter dh	ハブ長さ Hub Projection lh	全長 Overall Length l	キ み ぞ Key Way b ₂ × t ₂	ね じ Set Screw		重 量 Weight W(g)
											2-M(120°)	l _s	
S1S 21A - 0806F	21	φ21	φ23	A1	8	φ 6	-	-	8	-	-	-	19.1
S1S 21A - 1210F	21	φ21	φ23	A1	12	φ10	-	-	12	-	-	-	22.8
S1S 21B - 0806F	21	φ21	φ23	B1	8	φ 6	φ18	8	16	-	-	-	33.3
S1S 21B - 1208F	21	φ21	φ23	B1	12	φ 8	φ18	8	20	-	-	-	48.6
S1S 22A - 0806F	22	φ22	φ24	A1	8	φ 6	-	-	8	-	-	-	22.1
S1S 22A - 1210F	22	φ22	φ24	A1	12	φ10	-	-	12	-	-	-	28.4
S1S 22B - 0806F	22	φ22	φ24	B1	8	φ 6	φ18	8	16	-	-	-	36.3
S1S 22B - 1208F	22	φ22	φ24	B1	12	φ 8	φ18	8	20	-	-	-	43.9
S1S 23A - 0806F	23	φ23	φ25	A1	8	φ 6	-	-	8	-	-	-	24.3
S1S 23A - 1210F	23	φ23	φ25	A1	12	φ10	-	-	12	-	-	-	31.7
S1S 23B - 0806F	23	φ23	φ25	B1	8	φ 6	φ20	8	16	-	-	-	42.3
S1S 23B - 1208F	23	φ23	φ25	B1	12	φ 8	φ20	8	20	-	-	-	51.0

許容伝達動力表 曲げ強さ (W)

Allowable transfer capability table (W) Bending Strength

歯数 z	歯幅 b	焼入 H	回転速度 (min ⁻¹) revolution/min						
			10	100	200	400	800	1,200	1,500
21	8	-	6.68	66.81	133.62	267.24	534.47	765.05	913.19
21	12	-	10.02	100.21	200.43	400.86	801.71	1,147.57	1,369.79
22	8	-	7.15	71.52	143.04	286.09	572.18	811.72	967.23
22	12	-	10.73	107.28	214.57	429.13	858.27	1,217.58	1,450.84
23	8	-	7.63	76.28	152.56	305.11	610.23	858.05	1,020.71
23	12	-	11.44	114.42	228.84	457.67	915.34	1,287.07	1,531.06

The above numerical values are equivalent to JGMA formulas as reference only.

動力の換算式は P26 をご参照ください。Please refer to the conversion formula of power on page P26.

許容伝達動力表 歯面強さ (W)

Allowable transfer capability table (W) Surface Durability

回転速度 (min ⁻¹) revolution/min						
10	100	200	400	800	1,200	1,500
-	-	-	-	-	-	-
-	-	-	-	-	-	-
-	-	-	-	-	-	-
-	-	-	-	-	-	-
-	-	-	-	-	-	-
-	-	-	-	-	-	-

平歯車

SPUR GEARS

モジュール
MODULE

1

圧力角 20° (並歯) 歯数 24

20° PRESSURE ANGLE FULL DEPTH TOOTH Z 24

JIS B 1702-1 (ISO) 8 級
System of accuracy : JIS B 1702-1(ISO) class 8



御注文には必ず“フルネームで商品記号”を明記してください。
Please refer to the catalogue reference while ordering.

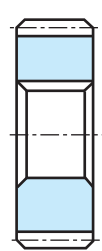

A1形
TYPE A1

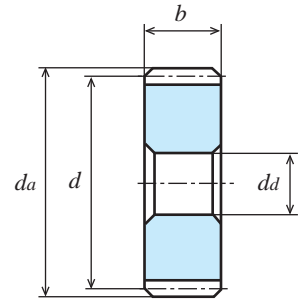
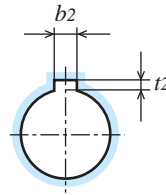

A1形
TYPE A1

S45C 機械構造用炭素鋼 (JIS G 4051)

Material : Carbon Steel (ISO C45)

単位 : mm
Dimensions : mm

商品記号 Catalogue Number	歯数 Number of Teeth z	基準円直径 Reference Diameter d	歯先円直径 Tip Diameter da	形 Type	歯幅 Face Width b	穴径 Bore Diameter da(H7)	ハブ外径 Hub Diameter dh	ハブ長さ Hub Projection lh	全長 Overall Length l	キ み ぞ Key Way b ₂ × t ₂	ねじ Set Screw		重量 Weight W(g)
											2-M(120°)	ls	
S1S 24A - 0806F	24	φ24	φ26	A1	8	φ 6	-	-	8	-	-	-	26.6
S1S 24A - 0808	24	φ24	φ26	A1	8	φ 8	-	-	8	-	-	-	25.3
S1S 24A - 1208F	24	φ24	φ26	A1	12	φ 8	-	-	12	-	-	-	37.9
S1S 24A = 1210	24	φ24	φ26	A1	12	φ10	-	-	12	3 × 1.4	-	-	34.8
S1S 24B - 0806	24	φ24	φ26	B1	8	φ 6	φ16	8	16	-	-	-	37.5
S1S 24B * 0806	24	φ24	φ26	B1	8	φ 6	φ16	8	16	-	2-M4	4	36.7
S1S 24B * 0808	24	φ24	φ26	B1	8	φ 8	φ16	8	16	-	2-M4	4	34.1
S1S 24B - 1006	24	φ24	φ26	B1	10	φ 6(H8)	φ20	10	20	-	-	-	55.77
S1S 24B - 1006H	24	φ24	φ26	B1	10	φ 6(H※)	φ20	10	20	-	-	-	55.77
S1S 24B * 1008	24	φ24	φ26	B1	10	φ 8	φ20	10	20	-	2-M5	5	50.7
S1S 24B - 1208F	24	φ24	φ26	B1	12	φ 8	φ20	8	20	-	-	-	54.5
S1S 24B * 1208	24	φ24	φ26	B1	12	φ 8	φ20	8	20	-	2-M4	4	53.5
S1S 24B * 1210	24	φ24	φ26	B1	12	φ10	φ20	8	20	-	2-M5	4	48.7

【=】(イコール)にはキー材が付いております。【=】: Gear with key way / with key.

【*】(アスタ)にはセットスクリューが2個付いております。【*】: Gear with two threaded holes / with two set screws.

カタログ記号の末尾に【H】を付した商品は歯部高周波焼入済です。Gear tooth surface completed with induction hardening, Hardness HRC47 to 53.

※ 歯部高周波焼入後の穴修正は行っていません。Bore correcting after induction hardening is not completed.

追加加工の際は、追加加工時の注意をご参照ください。Please refer to Precaution for additional process when additional process.

許容伝達動力表 曲げ強さ (W)

Allowable transfer capability table (W) Bending Strength

歯数 z	歯幅 b	焼入 H	回転速度 (min ⁻¹) revolution/min						
			10	100	200	400	800	1,200	1,500
24	8	-	8.10	81.04	162.07	324.14	647.77	903.58	1,073.09
24	10	-	10.13	101.29	202.59	405.18	809.71	1,129.47	1,341.36
24	10	○	11.21	112.05	224.09	448.18	896.36	1,187.47	1,484.34
24	12	-	12.16	121.55	243.11	486.21	971.65	1,355.36	1,609.63

The above numerical values are equivalent to JGMA formulas as reference only.

動力の換算式は P26 をご参照ください。Please refer to the conversion formula of power on page P26.

許容伝達動力表 歯面強さ (W)

Allowable transfer capability table (W) Surface Durability

回転速度 (min ⁻¹) revolution/min							
10	100	200	400	800	1,200	1,500	
-	-	-	-	-	-	-	-
0.47	4.71	9.63	19.27	38.54	54.03	65.97	
2.17	24.09	48.17	96.34	192.68	287.76	361.27	
-	-	-	-	-	-	-	-

目次
CONTENTS

インフォメーション
INFORMATION

ギヤボックス
GEAR BOXES

ノーバッキングギヤ
ANTI BACKLASH SPUR GEARS

歯研平歯車
GROUND SPUR GEARS

平歯車
SPUR GEARS

内歯車
INTERNAL GEARS

歯研ラック
GROUND RACKS

ラック
RACKS

ハニカムギヤ
HEXAGONAL GEAR AND SCREW GEARS

ウォーム
WORMS AND WORM WHEELS

かさ歯車
BEVEL GEARS

スプロケット
SPROCKETS

技術資料
REFERENCE DATA

平歯車

SPUR GEARS

モジュール
MODULE

1

圧力角 20° (並歯) 歯数 25 26

20° PRESSURE ANGLE FULL DEPTH TOOTH Z 25 to Z 26

JIS B 1702-1 (ISO) 8級 (高周波焼入品: 9級)
System of accuracy: JIS B 1702-1(ISO) class 8
(Induction hardened products: class 9)



New **ねじを2箇所 (120°配) にしました。**
締結力が**1.6倍**になりました。
New item with two threaded holes (120°)
Tightening power increased by 1.6 times.

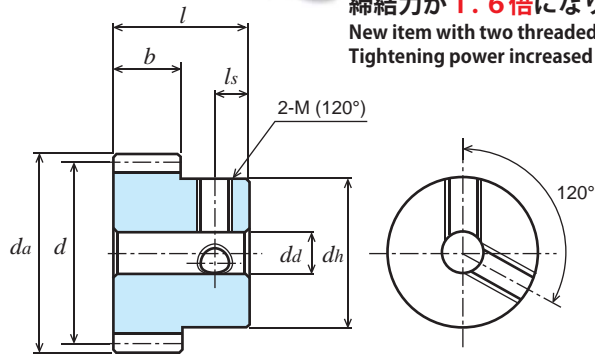

B1形
TYPE B1

S45C 機械構造用炭素鋼 (JIS G 4051)
Material: Carbon Steel (ISO C45)

単位: mm
Dimensions: mm

商品記号 Catalogue Number	歯数 Number of Teeth z	基準円直径 Reference Diameter d	歯先円直径 Tip Diameter da	形 Type	歯幅 Face Width b	穴径 Bore Diameter da(H7)	ハブ外径 Hub Diameter dh	ハブ長さ Hub Projection lh	全長 Overall Length l	キミぞ Key Way b ₂ × t ₂	ねじ Set Screw		重量 Weight W(g)
											2-M(120°)	ls	
S1S 25A - 0806F	25	φ25	φ27	A1	8	φ6	-	-	8	-	-	-	29.1
S1S 25A - 0808	25	φ25	φ27	A1	8	φ8	-	-	8	-	-	-	27.7
S1S 25A = 0810	25	φ25	φ27	A1	8	φ10	-	-	8	3 × 1.4	-	-	25.6
S1S 25A - 1208F	25	φ25	φ27	A1	12	φ8	-	-	12	-	-	-	41.5
S1S 25A = 1210	25	φ25	φ27	A1	12	φ10	-	-	12	3 × 1.4	-	-	38.5
S1S 25B - 0806	25	φ25	φ27	B1	8	φ6	φ16	8	16	-	-	-	39.9
S1S 25B * 0806	25	φ25	φ27	B1	8	φ6	φ16	8	16	-	2-M4	4	39.1
S1S 25B * 0808	25	φ25	φ27	B1	8	φ8	φ16	8	16	-	2-M4	4	36.5
S1S 25BF - 1005	25	φ25	φ27	B1	10	φ5(H8)	φ20	10	20	-	-	-	59.7
S1S 25B - 1006	25	φ25	φ27	B1	10	φ6(H8)	φ20	10	20	-	-	-	58.79
S1S 25B - 1005H	25	φ25	φ27	B1	10	φ5(H※)	φ20	10	20	-	-	-	59.7
S1S 25B * 1008	25	φ25	φ27	B1	10	φ8	φ20	10	20	-	2-M5	5	53.8
S1S 25B - 1208F	25	φ25	φ27	B1	12	φ8	φ20	8	20	-	-	-	58.1
S1S 25B * 1208	25	φ25	φ27	B1	12	φ8	φ20	8	20	-	2-M4	4	57.1
S1S 25B * 1210	25	φ25	φ27	B1	12	φ10	φ20	8	20	-	2-M5	4	52.4
S1S 26A - 0806F	26	φ26	φ28	A1	8	φ6	-	-	8	-	-	-	31.6
S1S 26A - 1208F	26	φ26	φ28	A1	12	φ8	-	-	12	-	-	-	45.3
S1S 26B - 0806F	26	φ26	φ28	B1	8	φ6	φ22	8	16	-	-	-	53.7
S1S 26B - 1208F	26	φ26	φ28	B1	12	φ8	φ22	8	20	-	-	-	66.0

●の商品は新商品です。Products with ● marks are new item.

【=】(イコール)にはキー材が付いております。 [=]: Gear with key way / with key.

【*】(アスタ)にはセットスクリューが2個付いております。[*]: Gear with two threaded holes / with two set screws.

カタログ記号の末尾に【H】を付した商品は歯部高周波焼入済です。Gear tooth surface completed with induction hardening, Hardness HRC47 to 53.

※
歯部高周波焼入後の穴修正は行っていません。Bore correcting after induction hardening is not completed.

追加加工の際は、追加加工時の注意をご参照ください。Please refer to Precaution for additional process when additional process.

許容伝達動力表 曲げ強さ (W)

Allowable transfer capability table (W) Bending Strength

歯数 z	歯幅 b	焼入 H	回転速度 (min ⁻¹) revolution/min						
			10	100	200	400	800	1,200	1,500
25	8	-	8.59	85.86	171.72	343.43	682.04	949.04	1,125.25
25	10	-	10.78	107.75	215.50	431.01	855.31	1,189.99	1,412.09
25	10	○	11.42	114.18	228.36	456.71	907.56	1,271.22	1,513.78
25	12	-	12.88	128.79	257.57	515.15	1,023.05	1,423.56	1,687.87
26	8	-	9.07	90.71	181.43	362.85	716.14	994.08	1,176.77
26	12	-	13.61	136.07	272.14	544.28	1,074.21	1,491.12	1,765.15

The above references are JGMA standard.

動力の換算式はP26をご参照ください。Please refer to the conversion formula of power on page P26.

許容伝達動力表 歯面強さ (W)

Allowable transfer capability table (W) Surface Durability

回転速度 (min ⁻¹) revolution/min						
10	100	200	400	800	1,200	1,500
-	-	-	-	-	-	-
0.51	5.13	10.47	20.94	41.89	59.06	70.68
2.32	25.62	52.84	108.93	223.17	318.11	382.55
-	-	-	-	-	-	-
-	-	-	-	-	-	-
-	-	-	-	-	-	-

平歯車

SPUR GEARS

モジュール
MODULE

1

圧力角 20° (並歯) 歯数 27 28
20° PRESSURE ANGLE FULL DEPTH TOOTH Z 27 to Z 28

JIS B 1702-1 (ISO) 8級
System of accuracy : JIS B 1702-1(ISO) class 8



御注文には必ず“フルネームで商品記号”を明記してください。

Please refer to the catalogue reference while ordering.

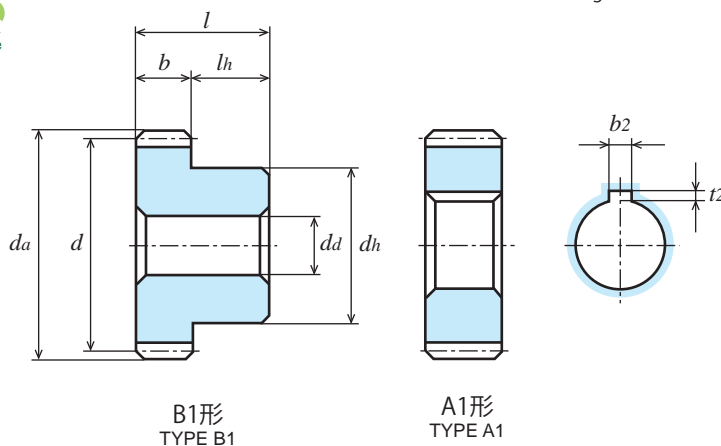

S45C 機械構造用炭素鋼 (JIS G 4051)

Material : Carbon Steel (ISO C45)

単位 : mm
Dimensions : mm

商品記号 Catalogue Number	歯数 Number of Teeth z	基準円直径 Reference Diameter d	歯先円直径 Tip Diameter da	形 Type	歯幅 Face Width b	穴径 Bore Diameter da(H7)	ハブ外径 Hub Diameter dh	ハブ長さ Hub Projection lh	全長 Overall Length l	キヤミぞ Key Way b ₂ × t ₂	ねじ Set Screw		重量 Weight W(g)
											2-M(120°)	ls	
S1S 27A - 0806F	27	φ27	φ29	A1	8	φ6	-	-	8	-	-	-	34.2
S1S 27A - 1208F	27	φ27	φ29	A1	12	φ8	-	-	12	-	-	-	49.2
S1S 27B - 0806F	27	φ27	φ29	B1	8	φ6	φ24	8	16	-	-	-	60.8
S1S 27B - 1208F	27	φ27	φ29	B1	12	φ8	φ24	8	20	-	-	-	74.5
S1S 28A - 0806F	28	φ28	φ30	A1	8	φ6	-	-	8	-	-	-	36.9
S1S 28A - 0808	28	φ28	φ30	A1	8	φ8	-	-	8	-	-	-	35.5
S1S 28A - 1208F	28	φ28	φ30	A1	12	φ8	-	-	12	-	-	-	55.3
S1S 28A = 1210	28	φ28	φ30	A1	12	φ10	-	-	12	3 × 1.4	-	-	50.2
S1S 28A = 1212	28	φ28	φ30	A1	12	φ12	-	-	12	4 × 1.8	-	-	46.7
S1S 28B - 0806	28	φ28	φ30	B1	8	φ6	φ20	8	16	-	-	-	54.9
S1S 28B * 0806	28	φ28	φ30	B1	8	φ6	φ20	8	16	-	2-M4	4	53.7
S1S 28B * 0808	28	φ28	φ30	B1	8	φ8	φ20	8	16	-	2-M4	4	51.1
S1S 28B * 0810	28	φ28	φ30	B1	8	φ10	φ20	8	16	-	2-M5	4	52.0
S1S 28B - 1008	28	φ28	φ30	B1	10	φ8(H7)	φ24	10	20	-	-	-	76.01
S1S 28B - 1008H	28	φ28	φ30	B1	10	φ8(H※)	φ24	10	20	-	-	-	76.01
S1S 28B * 1010	28	φ28	φ30	B1	10	φ10	φ24	10	20	-	2-M5	5	69.7
S1S 28B - 1210F	28	φ28	φ30	B1	12	φ10	φ24	8	20	-	-	-	74.1
S1S 28B * 1210	28	φ28	φ30	B1	12	φ10	φ24	8	20	-	2-M5	4	72.3
S1S 28B * 1212	28	φ28	φ30	B1	12	φ12	φ24	8	20	-	2-M5	4	67.1

[=] (イコール)にはキヤミが付いております。 [=]: Gear with Key Way / with Key.

[*] (アスタ)にはセットスクリューが2個付いております。 [*]: Gear with two threaded holes / with two set screws.

カタログ記号の末尾に【H】を付した商品は歯部高周波焼入済です。 Gear tooth surface completed with induction hardening, Hardness HRC47 to 53.

※
歯部高周波焼入後の穴修正は行っていません。 Bore correcting after induction hardening is not completed.

追加加工の際は、追加加工時の注意をご参照ください。 Please refer to Precaution for additional process when additional process.

許容伝達動力表 曲げ強さ (W)

Allowable transfer capability table (W) Bending Strength

歯数 z	歯幅 b	焼入 H	回転速度 (min ⁻¹) revolution/min						
			10	100	200	400	800	1,200	1,500
27	8	-	9.56	95.60	191.20	382.40	750.06	1,038.69	1,227.65
27	12	-	14.34	143.40	286.80	573.60	1,125.09	1,558.03	1,841.47
28	8	-	10.05	100.52	201.03	402.06	783.81	1,082.86	1,277.89
28	10	-	12.56	125.65	251.29	502.58	979.76	1,353.58	1,597.36
28	10	○	13.51	135.08	270.17	540.33	1,080.66	1,407.37	1,759.22
28	12	-	15.08	150.77	301.55	603.10	1,175.71	1,624.29	1,916.83

The above numerical values are equivalent to JGMA formulas as reference only.

動力の換算式は P26 をご参照ください。 Please refer to the conversion formula of power on page P26.

許容伝達動力表 歯面強さ (W)

Allowable transfer capability table (W) Surface Durability

回転速度 (min ⁻¹) revolution/min						
10	100	200	400	800	1,200	1,500
-	-	-	-	-	-	-
-	-	-	-	-	-	-
-	-	-	-	-	-	-
0.66	6.60	13.19	26.81	52.78	74.14	87.96
3.04	32.15	64.30	128.59	257.18	385.77	482.21
-	-	-	-	-	-	-

目次
CONTENTS

インフォメーション
INFORMATION

ギヤボックス
GEAR BOXES

ノーバッキングギヤ
ANTI BACKLASH SPUR GEARS

歯研削歯車
GROUND SPUR GEARS

歯研削歯車
SPUR GEARS

内歯車
INTERNAL GEARS

歯研削ラック
GROUND RACKS

ラック
RACKS

ハブ・スクリューギヤ
HEUCAL GEARS AND SCREW GEARS

ワーム・ワームギヤ
WORMS AND WORM GEARS

かさ歯車
BEVEL GEARS

スプロケット
SPROCKETS

技術資料
REFERENCE DATA

平歯車 SPUR GEARS

モジュール
MODULE

1

圧力角 20° (並歯) 歯数 30

20° PRESSURE ANGLE FULL DEPTH TOOTH Z30

JIS B 1702-1 (ISO) 8級 (高周波焼入品: 9級)
System of accuracy: JIS B 1702-1(ISO) class 8
(Induction hardened products: class 9)



New **ねじを2箇所 (120°配) にしました。**
締結力が1.6倍になりました。
New item with two threaded holes (120°)
Tightening power increased by 1.6 times.

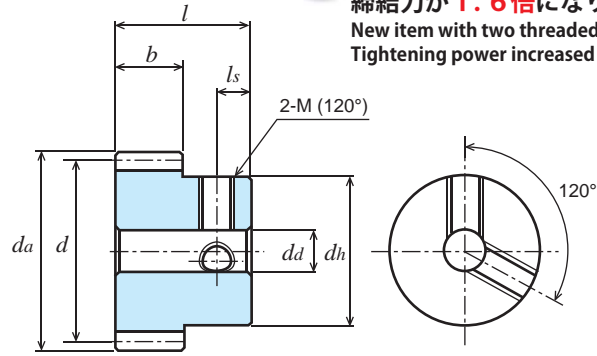

B1形
TYPE B1

S45C 機械構造用炭素鋼 (JIS G 4051) Material: Carbon Steel (ISO C45)

単位: mm
Dimensions: mm

商品記号 Catalogue Number	歯数 Number of Teeth z	基準円直径 Reference Diameter d	歯先円直径 Tip Diameter da	形 Type	歯幅 Face Width b	穴径 Bore Diameter da(H7)	ハブ外径 Hub Diameter dh	ハブ長さ Hub Projection lh	全長 Overall Length l	キミぞ Key Way b ₂ × t ₂	ねじ Set Screw		重量 Weight W(g)
											2-M(120°)	ls	
S1S 30A - 0808F	30	φ30	φ32	A1	8	φ8	-	-	8	-	-	-	41.2
S1S 30A = 0810	30	φ30	φ32	A1	8	φ10	-	-	8	3 × 1.4	-	-	39.2
S1S 30A = 1010	30	φ30	φ32	A1	10	φ10	-	-	10	3 × 1.4	-	-	49.0
S1S 30A - 1208F	30	φ30	φ32	A1	12	φ8	-	-	12	-	-	-	61.9
S1S 30A = 1210	30	φ30	φ32	A1	12	φ10	-	-	12	3 × 1.4	-	-	58.8
S1S 30A = 1212	30	φ30	φ32	A1	12	φ12	-	-	12	4 × 1.8	-	-	55.3
S1S 30B - 0806	30	φ30	φ32	B1	8	φ6	φ24	8	16	-	-	-	69.3
S1S 30B * 0806	30	φ30	φ32	B1	8	φ6	φ24	8	16	-	2-M4	4	67.8
S1S 30B * 0808	30	φ30	φ32	B1	8	φ8	φ24	8	16	-	2-M4	4	65.2
S1S 30B * 0810	30	φ30	φ32	B1	8	φ10	φ24	8	16	-	2-M5	4	61.1
S1S 30B * 0812	30	φ30	φ32	B1	8	φ12	φ24	8	16	-	2-M5	4	57.1
● S1S 30BF - 1006	30	φ30	φ32	B1	10	φ6(H8)	φ25	10	20	-	-	-	89.1
● S1S 30B - 1006H	30	φ30	φ32	B1	10	φ6(H※)	φ25	10	20	-	-	-	89.1
● S1S 30B - 1008	30	φ30	φ32	B1	10	φ8	φ25	10	20	-	-	-	86.19
S1S 30B * 1010	30	φ30	φ32	B1	10	φ10	φ25	10	20	-	2-M5	5	79.8
S1S 30B - 1210	30	φ30	φ32	B1	12	φ10	φ24	8	20	-	-	-	82.7
S1S 30B * 1210	30	φ30	φ32	B1	12	φ10	φ24	8	20	-	2-M5	4	80.9
S1S 30B * 1212	30	φ30	φ32	B1	12	φ12	φ24	8	20	-	2-M5	4	75.7

●の商品は新商品です。Products with ● marks are new item.

【=】(イコール)にはキマ材が付いております。[=]: Gear with key way / with key.

【*】(アスタ)にはセットスクリーが2個付いております。[*]: Gear with two threaded holes / with two set screws.

カタログ記号の末尾に【H】を付した商品は歯部高周波焼入済です。Gear tooth surface completed with induction hardening, Hardness HRC47 to 53.

※
歯部高周波焼入後の穴修正は行っていません。Bore correcting after induction hardening is not completed.

追加加工の際は、追加加工時の注意をご参照ください。Please refer to Precaution for additional process when additional process.

許容伝達動力表 曲げ強さ (W)

Allowable transfer capability table (W) Bending Strength

歯数 z	歯幅 b	焼入 H	回転速度 (min ⁻¹) revolution/min						
			10	100	200	400	800	1,200	1,500
30	8	-	11.04	110.37	220.74	441.48	850.22	1,169.22	1,375.68
30	10	-	13.81	138.12	276.24	552.48	1,063.91	1,462.66	1,721.52
30	10	○	14.64	146.41	292.81	585.63	1,131.61	1,567.73	1,853.36
30	12	-	16.56	165.55	331.11	662.22	1,275.33	1,753.83	2,063.52

The above references are JGMA standard.

動力の換算式は P26 をご参照ください。Please refer to the conversion formula of power on page P26.

許容伝達動力表 歯面強さ (W)

Allowable transfer capability table (W) Surface Durability

回転速度 (min ⁻¹) revolution/min						
10	100	200	400	800	1,200	1,500
0.75	-	-	-	-	-	-
0.75	7.64	15.29	30.58	60.32	84.19	100.53
3.39	37.55	77.41	159.60	317.91	448.27	535.15
-	-	-	-	-	-	-

平歯車

SPUR GEARS

モジュール
MODULE

1

圧力角 20° (並歯) 歯数 32 34

20° PRESSURE ANGLE FULL DEPTH TOOTH Z 32 to Z 34

JIS B 1702-1 (ISO) 8級
System of accuracy : JIS B 1702-1(ISO) class 8



御注文には必ず“フルネームで商品記号”を明記してください。

Please refer to the catalogue reference while ordering.

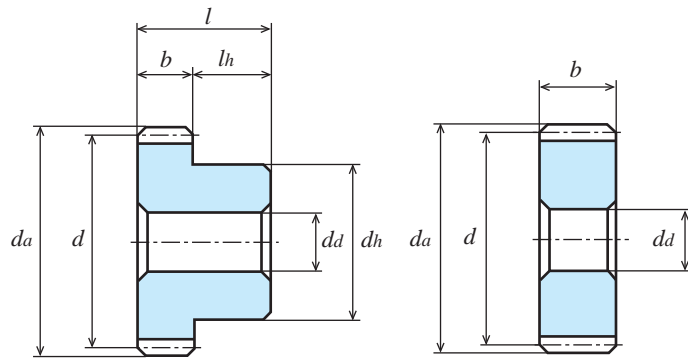

B1形
TYPE B1

A1形
TYPE A1

S45C 機械構造用炭素鋼 (JIS G 4051)

Material : Carbon Steel (ISO C45)

単位 : mm
Dimensions : mm

商品記号 Catalogue Number	歯数 Number of Teeth z	基準円直径 Reference Diameter d	歯先円直径 Tip Diameter da	形 Type	歯幅 Face Width b	穴径 Bore Diameter da(H7)	ハブ外 径 Hub Diameter dh	ハブ長 さ Hub Projection lh	全長 Overall Length l	キー みぞ Key Way b ₂ × t ₂	ねじ Set Screw		重量 Weight W(g)
											2-M(120°)	l _s	
S1S 32A - 0608F	32	φ32	φ34	A1	6	φ 8	-	-	6	-	-	-	35.5
S1S 32A = 0610	32	φ32	φ34	A1	6	φ10	-	-	6	3 × 1.4	-	-	34.0
S1S 32A = 0612	32	φ32	φ34	A1	6	φ12	-	-	6	4 × 1.8	-	-	32.2
S1S 32A - 1008F	32	φ32	φ34	A1	10	φ 8	-	-	10	-	-	-	59.2
S1S 32A = 1010	32	φ32	φ34	A1	10	φ10	-	-	10	3 × 1.4	-	-	56.6
S1S 32A = 1012	32	φ32	φ34	A1	10	φ12	-	-	10	4 × 1.8	-	-	53.7
S1S 32B - 0606	32	φ32	φ34	B1	6	φ 6	φ24	10	16	-	-	-	69.9
S1S 32B * 0606	32	φ32	φ34	B1	6	φ 6	φ24	10	16	-	2-M4	4	68.4
S1S 32B * 0608	32	φ32	φ34	B1	6	φ 8	φ24	10	16	-	2-M4	4	65.8
S1S 32B * 0610	32	φ32	φ34	B1	6	φ10	φ24	10	16	-	2-M5	5	61.7
S1S 32B * 0612	32	φ32	φ34	B1	6	φ12	φ24	10	16	-	2-M5	5	57.7
S1S 32B - 1010	32	φ32	φ34	B1	10	φ10	φ24	10	20	-	-	-	86.4
S1S 32B * 1010	32	φ32	φ34	B1	10	φ10	φ24	10	20	-	2-M5	5	84.5
S1S 32B * 1012	32	φ32	φ34	B1	10	φ12	φ24	10	20	-	2-M5	5	79.4
S1S 34A - 0608F	34	φ34	φ36	A1	6	φ 8	-	-	6	-	-	-	40.4
S1S 34A - 1008F	34	φ34	φ36	A1	10	φ 8	-	-	10	-	-	-	67.3
S1S 34B - 0606F	34	φ34	φ36	B1	6	φ 6	φ28	10	16	-	-	-	87.6
S1S 34B - 1010F	34	φ34	φ36	B1	10	φ10	φ28	10	20	-	-	-	107.3

[=] (イコール)にはキー材が付いております。 [=] : Gear with key way / with key.

[*] (アスタ)にはセットスクリーンが2個付いております。 [*] : Gear with two threaded holes / with two set screws.

許容伝達動力表 曲げ強さ (W)

Allowable transfer capability table (W) Bending Strength

歯数 z	歯幅 b	回転速度 (min ⁻¹) revolution/min							回転速度 (min ⁻¹) revolution/min
		10	100	200	400	800	1,200	1,500	
32	6	9.03	90.27	180.53	361.07	687.05	940.61	1,103.51	100
32	10	15.04	150.45	300.89	601.78	1,145.09	1,567.69	1,839.19	8.62
34	6	9.78	97.82	195.64	391.27	735.73	1,002.88	1,173.30	14.36
34	10	16.30	163.03	326.06	652.12	1,226.22	1,671.47	1,955.49	9.34
									15.56

The above numerical values are equivalent to JGMA formulas as reference only.

動力の換算式は P26 をご参照ください。 Please refer to the conversion formula of power on page P26.

目次
CONTENTS
インフォメーション
INFORMATION
ギヤボックス
GEAR BOXES
ノーバッキングギヤ
ANTI BACKLASH SPUR GEARS
歯研削歯車
GROUND SPUR GEARS
歯研削歯車
SPUR GEARS
内歯車
INTERNAL GEARS
歯研削ラック
GROUND RACKS
ラック
RACKS
へリカル・スクリューギヤ
HELICAL GEARS AND SCREW GEARS
ワーム・アンド・ウォームギヤ
WORMS AND WORM GEARS
かさ歯車
BEVEL GEARS
スプロケット
SPROCKETS
技術資料
REFERENCE DATA

平歯車 SPUR GEARS

モジュール
MODULE

1

圧力角 20° (並歯) 歯数 35
20° PRESSURE ANGLE FULL DEPTH TOOTH Z35

JIS B 1702-1 (ISO) 8級
System of accuracy : JIS B 1702-1(ISO) class 8



New ねじを2箇所 (120°配) にしました。
締結力が1.6倍になりました。
New item with two threaded holes (120°)
Tightening power increased by 1.6 times.

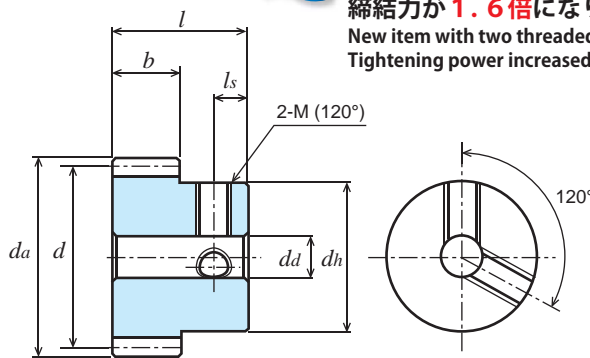

B1形
TYPE B1

S45C 機械構造用炭素鋼 (JIS G 4051)
Material : Carbon Steel (ISO C45)

単位 : mm
Dimensions : mm

商品記号 Catalogue Number	歯数 Number of Teeth z	基準円直径 Reference Diameter d	歯先円直径 Tip Diameter da	形 Type	歯幅 Face Width b	穴径 Bore Diameter da(H7)	ハブ外径 Hub Diameter dh	ハブ長さ Hub Projection lh	全長 Overall Length l	キミぞ Key Way b ₂ × t ₂	ねじ Set Screw		重量 Weight W(g)
											2-M(120°)	ls	
S1S 35A - 0608F	35	φ35	φ37	A1	6	φ8	-	-	6	-	-	-	43.0
S1S 35A = 0610	35	φ35	φ37	A1	6	φ10	-	-	6	3 × 1.4	-	-	41.4
S1S 35A = 0612	35	φ35	φ37	A1	6	φ12	-	-	6	4 × 1.8	-	-	39.7
S1S 35A - 1008F	35	φ35	φ37	A1	10	φ8	-	-	10	-	-	-	71.6
S1S 35A = 1010	35	φ35	φ37	A1	10	φ10	-	-	10	3 × 1.4	-	-	69.0
S1S 35A = 1012	35	φ35	φ37	A1	10	φ12	-	-	10	4 × 1.8	-	-	66.1
S1S 35A = 1015	35	φ35	φ37	A1	10	φ15	-	-	10	5 × 2.3	-	-	60.8
S1S 35B - 0606	35	φ35	φ37	B1	6	φ6	φ24	10	16	-	-	-	77.3
S1S 35B * 0606	35	φ35	φ37	B1	6	φ6	φ24	10	16	-	2-M4	4	75.8
S1S 35B * 0608	35	φ35	φ37	B1	6	φ8	φ24	10	16	-	2-M4	4	73.2
S1S 35B * 0610	35	φ35	φ37	B1	6	φ10	φ24	10	16	-	2-M5	5	69.2
S1S 35B * 0612	35	φ35	φ37	B1	6	φ12	φ24	10	16	-	2-M5	5	65.1
S1S 35B - 1010F	35	φ35	φ37	B1	10	φ10	φ30	10	20	-	-	-	118.7
S1S 35B * 1010	35	φ35	φ37	B1	10	φ10	φ30	10	20	-	2-M5	5	116.1
S1S 35B * 1012	35	φ35	φ37	B1	10	φ12	φ30	10	20	-	2-M5	5	111.0
S1S 35B * 1015	35	φ35	φ37	B1	10	φ15	φ30	10	20	-	2-M5	5	101.4

【=】(イコール)にはキー材が付いております。【=】: Gear with key way / with key.

【*】(アスタ)にはセットスクリューが2個付いております。【*】: Gear with two threaded holes / with two set screws.

許容伝達動力表 曲げ強さ (W)

T (N · m)

Allowable transfer capability table (W) Bending Strength

歯数 z	歯幅 b	回転速度 (min ⁻¹) revolution/min						回転速度 (min ⁻¹) revolution/min	
		10	100	200	400	800	1,200	1,500	100
35	6	10.16	101.61	203.23	406.46	759.80	1,033.48	1,207.46	9.70
35	10	16.94	169.36	338.72	677.43	1,266.33	1,722.47	2,012.43	16.17

KG規格は“並幅”(軽荷重用)と“広幅”(重荷重用)があります。ご用途に応じてお選び下さい。

KG STOCK GEARS has Wide-face width for Heavy load, and Standard-face width for Light load.

You are able to multiple choices for your suitable design from our wide range.

The above numerical values are equivalent to JGMA formulas as reference only.

動力の換算式はP26をご参照ください。Please refer to the conversion formula of power on page P26.

平歯車

SPUR GEARS

モジュール
MODULE

1

圧力角 20° (並歯) 歯数 36 38
20° PRESSURE ANGLE FULL DEPTH TOOTH Z36 to Z38

JIS B 1702-1 (ISO) 8級
System of accuracy : JIS B 1702-1(ISO) class 8



御注文には必ず“フルネームで商品記号”を明記してください。
Please refer to the catalogue reference while ordering.

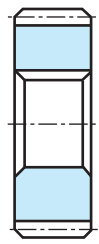

A1形
TYPE A1

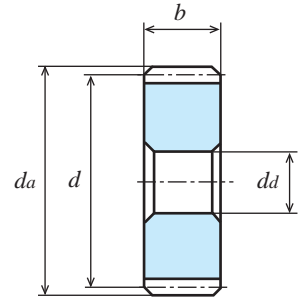
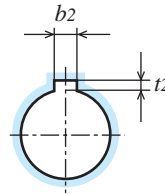

A1形
TYPE A1

S45C 機械構造用炭素鋼 (JIS G 4051)

Material : Carbon Steel (ISO C45)

単位 : mm
Dimensions : mm

商品記号 Catalogue Number	歯数 Number of Teeth z	基準円直径 Reference Diameter d	歯先円直径 Tip Diameter da	形 Type	歯幅 Face Width b	穴径 Bore Diameter da(H7)	ハブ外径 Hub Diameter dh	ハブ長さ Hub Projection lh	全長 Overall Length l	キミぞ Key Way b ₂ × t ₂	ねじ Set Screw		重量 Weight W(g)
											2-M(120°)	l _s	
S1S 36A - 0608F	36	φ36	φ38	A1	6	φ8	-	-	6	-	-	-	45.6
S1S 36A = 0610	36	φ36	φ38	A1	6	φ10	-	-	6	3 × 1.4	-	-	44.0
S1S 36A = 0612	36	φ36	φ38	A1	6	φ12	-	-	6	4 × 1.8	-	-	42.3
S1S 36A - 1008F	36	φ36	φ38	A1	10	φ8	-	-	10	-	-	-	76.0
S1S 36A = 1010	36	φ36	φ38	A1	10	φ10	-	-	10	3 × 1.4	-	-	73.4
S1S 36A = 1012	36	φ36	φ38	A1	10	φ12	-	-	10	4 × 1.8	-	-	70.5
S1S 36A = 1015	36	φ36	φ38	A1	10	φ15	-	-	10	5 × 2.3	-	-	65.1
S1S 36B - 0608	36	φ36	φ38	B1	6	φ8	φ24	10	16	-	-	-	77.2
S1S 36B * 0608	36	φ36	φ38	B1	6	φ8	φ24	10	16	-	2-M4	4	75.9
S1S 36B * 0610	36	φ36	φ38	B1	6	φ10	φ24	10	16	-	2-M5	5	71.8
S1S 36B * 0612	36	φ36	φ38	B1	6	φ12	φ24	10	16	-	2-M5	5	67.7
S1S 36B - 1010F	36	φ36	φ38	B1	10	φ10	φ30	10	20	-	-	-	123.1
S1S 36B * 1010	36	φ36	φ38	B1	10	φ10	φ30	10	20	-	2-M5	5	120.5
S1S 36B * 1012	36	φ36	φ38	B1	10	φ12	φ30	10	20	-	2-M5	5	115.4
S1S 36B * 1015	36	φ36	φ38	B1	10	φ15	φ30	10	20	-	2-M5	5	105.8
S1S 38A - 0608F	38	φ38	φ40	A1	6	φ8	-	-	6	-	-	-	51.1
S1S 38A - 1008F	38	φ38	φ40	A1	10	φ8	-	-	10	-	-	-	85.1
S1S 38B - 0608F	38	φ38	φ40	B1	6	φ8	φ25	10	16	-	-	-	85.6
S1S 38B - 1010F	38	φ38	φ40	B1	10	φ10	φ30	10	20	-	-	-	132.2

【=】(イコール)にはキー材が付いております。【=】: Gear with key way / with key.
【*】(アスタ)にはセットスクリューが2個付いております。【*】: Gear with two threaded holes / with two set screws.

許容伝達動力表 曲げ強さ (W)

T (N · m)

Allowable transfer capability table (W) Bending Strength

歯数 z	歯幅 b	回転速度 (min ⁻¹) revolution/min							回転速度 (min ⁻¹) revolution/min
		10	100	200	400	800	1,200	1,500	
36	6	10.54	105.42	210.85	421.69	783.68	1,063.73	1,241.14	100
36	10	17.57	175.71	351.41	702.82	1,306.12	1,772.88	2,068.56	10.06
38	6	11.31	113.08	226.15	452.31	830.87	1,123.15	1,307.07	16.77
38	10	18.85	188.46	376.92	753.85	1,384.78	1,871.91	2,178.45	10.79
									17.99

The above numerical values are equivalent to JGMA formulas as reference only.
動力の換算式は P26 をご参照ください。Please refer to the conversion formula of power on page P26.

目次
CONTENTS

インフォメーション
INFORMATION

ギヤボックス
GEAR BOXES

ノーバッキングギヤ
ANTI BACKLASH SPUR GEARS

歯研平歯車
GROUND SPUR GEARS

歯研ラック
GROUND RACKS

内歯車
INTERNAL GEARS

ラック
RACKS

ハニカムギヤ
HEXAGONAL GEAR AND SCREW GEARS

ワームとワームホイール
WORMS AND WORM WHEELS

かさ歯車
BEVEL GEARS

スプロケット
SPROCKETS

技術資料
REFERENCE DATA

平歯車 SPUR GEARS

モジュール
MODULE

1

圧力角 20° (並歯) 歯数 40

20° PRESSURE ANGLE FULL DEPTH TOOTH Z 40

JIS B 1702-1 (ISO) 8級 (高周波焼入品: 9級)
System of accuracy: JIS B 1702-1(ISO) class 8
(Induction hardened products: class 9)



New **ねじを2箇所 (120°配) にしました。**
締結力が**1.6倍**になりました。
New item with two threaded holes (120°)
Tightening power increased by 1.6 times.

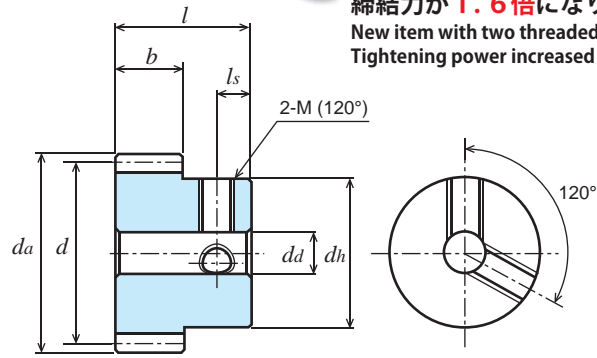

B1形
TYPE B1

S45C 機械構造用炭素鋼 (JIS G 4051)
Material: Carbon Steel (ISO C45)

単位: mm
Dimensions: mm

商品記号 Catalogue Number	歯数 Number of Teeth z	基準円直径 Reference Diameter d	歯先円直径 Tip Diameter da	形 Type	歯幅 Face Width b	穴径 Bore Diameter da(H7)	ハブ外径 Hub Diameter dh	ハブ長さ Hub Projection lh	全長 Overall Length l	キミぞ Key Way b ₂ × t ₂	ねじ Set Screw		重量 Weight W(g)
											2-M(120°)	ls	
S1S 40A - 0608F	40	φ40	φ42	A1	6	φ8	-	-	6	-	-	-	56.8
S1S 40A = 0610	40	φ40	φ42	A1	6	φ10	-	-	6	3 × 1.4	-	-	55.3
S1S 40A = 0612	40	φ40	φ42	A1	6	φ12	-	-	6	4 × 1.8	-	-	53.5
S1S 40A - 1008F	40	φ40	φ42	A1	10	φ8	-	-	10	-	-	-	94.7
S1S 40A = 1010	40	φ40	φ42	A1	10	φ10	-	-	10	3 × 1.4	-	-	92.2
S1S 40A = 1012	40	φ40	φ42	A1	10	φ12	-	-	10	4 × 1.8	-	-	89.2
S1S 40A = 1015	40	φ40	φ42	A1	10	φ15	-	-	10	5 × 2.3	-	-	83.9
S1S 40B - 0608	40	φ40	φ42	B1	6	φ8	φ24	10	16	-	-	-	88.4
S1S 40B * 0608	40	φ40	φ42	B1	6	φ8	φ24	10	16	-	2-M4	4	87.1
S1S 40B * 0610	40	φ40	φ42	B1	6	φ10	φ24	10	16	-	2-M5	5	83.1
S1S 40B * 0612	40	φ40	φ42	B1	6	φ12	φ24	10	16	-	2-M5	5	79.0
S1S 40BF - 1006	40	φ40	φ42	B1	10	φ6(H8)	φ30	10	20	-	-	-	149.1
S1S 40B - 1006H	40	φ40	φ42	B1	10	φ6(H※)	φ30	10	20	-	-	-	149.1
S1S 40B - 1010F	40	φ40	φ42	B1	10	φ10	φ30	10	20	-	-	-	141.8
S1S 40B * 1010	40	φ40	φ42	B1	10	φ10	φ30	10	20	-	2-M5	5	139.3
S1S 40B * 1012	40	φ40	φ42	B1	10	φ12	φ30	10	20	-	2-M5	5	134.1
S1S 40B * 1015	40	φ40	φ42	B1	10	φ15	φ30	10	20	-	2-M5	5	124.5

●の商品は新商品です。Products with ● marks are new item.

【=】(イコール)にはキー材が付いております。 [=]: Gear with key way / with key.

【*】(アスタ)にはセットスクリューが2個付いております。[*]: Gear with two threaded holes / with two set screws.

カタログ記号の末尾に【H】を付した商品は歯部高周波焼入済です。Gear tooth surface completed with induction hardening, Hardness HRC47 to 53.

※ 歯部高周波焼入後の穴修正は行っていません。Bore correcting after induction hardening is not completed.

追加加工の際は、追加加工時の注意をご参照ください。Please refer to Precaution for additional process when additional process.

許容伝達動力表 曲げ強さ (W)

Allowable transfer capability table (W) Bending Strength

歯数 z	歯幅 b	焼入 H	回転速度 (min ⁻¹) revolution/min						
			10	100	200	400	800	1,200	1,500
40	6	-	12.08	120.78	241.55	483.10	877.30	1,181.18	1,386.01
40	10	-	20.08	200.84	401.69	803.38	1,459.31	1,964.04	2,304.26
40	10	○	21.29	212.94	425.87	851.74	1,559.77	2,118.06	2,496.93

The above references are JGMA standard.

動力の換算式は P26 をご参照ください。Please refer to the conversion formula of power on page P26.

許容伝達動力表 歯面強さ (W)

Allowable transfer capability table (W) Surface Durability

回転速度 (min ⁻¹) revolution/min						
10	100	200	400	800	1,200	1,500
-	-	-	-	-	-	-
1.39	13.93	28.06	56.55	104.72	144.51	171.21
6.20	68.60	141.44	291.61	550.48	760.95	905.8

平歯車

SPUR GEARS

モジュール
MODULE

1

圧力角 20° (並歯) 歯数 42 ~ 45
20° PRESSURE ANGLE FULL DEPTH TOOTH Z 42 to Z 45

JIS B 1702-1 (ISO) 8級
System of accuracy : JIS B 1702-1(ISO) class 8



御注文には必ず“フルネームで商品記号”を明記してください。
Please refer to the catalogue reference while ordering.

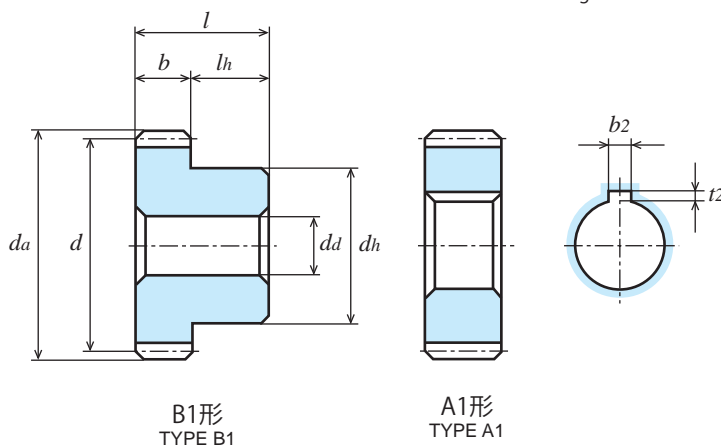

S45C 機械構造用炭素鋼 (JIS G 4051) Material : Carbon Steel (ISO C45)

単位 : mm
Dimensions : mm

商品記号 Catalogue Number	歯数 Number of Teeth z	基準円直径 Reference Diameter d	歯先円直径 Tip Diameter da	形 Type	歯幅 Face Width b	穴径 Bore Diameter dd(H7)	ハブ外径 Hub Diameter dh	ハブ長さ Hub Projection lh	全長 Overall Length l	キ み ぞ Key Way b ₂ × t ₂	ねじ Set Screw		重量 Weight W(g)
											2-M(120°)	ls	
S1S 42A - 0608F	42	φ42	φ44	A1	6	φ 8	-	-	6	-	-	-	62.9
S1S 42A - 1008F	42	φ42	φ44	A1	10	φ 8	-	-	10	-	-	-	104.8
S1S 42B - 0608F	42	φ42	φ44	B1	6	φ 8	φ28	10	16	-	-	-	107.3
S1S 42B - 1010F	42	φ42	φ44	B1	10	φ10	φ30	10	20	-	-	-	151.9
S1S 44A - 0608F	44	φ44	φ46	A1	6	φ 8	-	-	6	-	-	-	69.3
S1S 44A - 1008F	44	φ44	φ46	A1	10	φ 8	-	-	10	-	-	-	115.4
S1S 44B - 0608F	44	φ44	φ46	B1	6	φ 8	φ28	10	16	-	-	-	113.6
S1S 44B - 1010F	44	φ44	φ46	B1	10	φ10	φ30	10	20	-	-	-	162.5
S1S 45A - 0608F	45	φ45	φ47	A1	6	φ 8	-	-	6	-	-	-	72.5
S1S 45A = 0610	45	φ45	φ47	A1	6	φ10	-	-	6	3 × 1.4	-	-	71.0
S1S 45A = 0612	45	φ45	φ47	A1	6	φ12	-	-	6	4 × 1.8	-	-	69.2
S1S 45A - 1008F	45	φ45	φ47	A1	10	φ 8	-	-	10	-	-	-	120.9
S1S 45A = 1010	45	φ45	φ47	A1	10	φ10	-	-	10	3 × 1.4	-	-	118.4
S1S 45A = 1012	45	φ45	φ47	A1	10	φ12	-	-	10	4 × 1.8	-	-	115.4
S1S 45A = 1015	45	φ45	φ47	A1	10	φ15	-	-	10	5 × 2.3	-	-	110.1
S1S 45B - 0608	45	φ45	φ47	B1	6	φ 8	φ24	10	16	-	-	-	104.2
S1S 45B * 0608	45	φ45	φ47	B1	6	φ 8	φ24	10	16	-	2-M4	4	102.9
S1S 45B * 0610	45	φ45	φ47	B1	6	φ10	φ24	10	16	-	2-M5	5	98.8
S1S 45B * 0612	45	φ45	φ47	B1	6	φ12	φ24	10	16	-	2-M5	5	94.7
S1S 45B - 1010F	45	φ45	φ47	B1	10	φ10	φ30	10	20	-	-	-	168.0
S1S 45B * 1010	45	φ45	φ47	B1	10	φ10	φ30	10	20	-	2-M5	5	165.5
S1S 45B * 1012	45	φ45	φ47	B1	10	φ12	φ30	10	20	-	2-M5	5	160.3
S1S 45B * 1015	45	φ45	φ47	B1	10	φ15	φ30	10	20	-	2-M5	5	150.7

【=】(イコール)にはキー材が付いております。【=】: Gear with key way / with key.

【*】(アスタ)にはセットスクリューが2個付いております。【*】: Gear with two threaded holes / with two set screws.

許容伝達動力表 曲げ強さ (W)

Allowable transfer capability table (W) Bending Strength

歯数 z	歯幅 b	回転速度 (min ⁻¹) revolution/min							回転速度 (min ⁻¹) revolution/min
		10	100	200	400	800	1,200	1,500	
42	6	12.85	128.51	257.02	514.05	922.98	1,237.83	1,465.99	12.27
42	10	21.42	214.19	428.37	856.75	1,538.29	2,063.06	2,443.32	20.45
44	6	13.62	136.19	272.39	544.77	967.23	1,292.26	1,544.38	13.00
44	10	22.70	226.99	453.98	907.95	1,612.04	2,153.77	2,573.97	21.67
45	6	14.01	140.08	280.17	560.34	989.34	1,319.35	1,583.81	13.37
45	10	23.35	233.47	466.95	933.89	1,648.90	2,198.92	2,639.68	22.29

The above numerical values are equivalent to JGMA formulas as reference only.

動力の換算式は P26 をご参照ください。Please refer to the conversion formula of power on page P26.

目次 CONTENTS
インフォメーション INFORMATION
ギヤボックス GEAR BOXES
ノーバッキングギヤ ANTI BACKLASH SPUR GEARS
歯研削歯車 GROUND SPUR GEARS
歯車 SPUR GEARS
内歯車 INTERNAL GEARS
歯ラック GROUND RACKS
ラック RACKS
ワーム・スクリューギヤ HEILICAL GEARS AND SCREW GEARS
ワーム・ギヤ WORMS AND WORM WHEELS
かみ歯車 BEVEL GEARS
スプロケット SPROCKETS
技術データ REFERENCE DATA

平歯車

SPUR GEARS

モジュール
MODULE

1

圧力角 20° (並歯) 歯数 46 48
20° PRESSURE ANGLE FULL DEPTH TOOTH Z 46 to Z 48

JIS B 1702-1 (ISO) 8級
System of accuracy : JIS B 1702-1(ISO) class 8



New **ねじを2箇所 (120°配) にしました。**
締結力が1.6倍になりました。
New item with two threaded holes (120°)
Tightening power increased by 1.6 times.

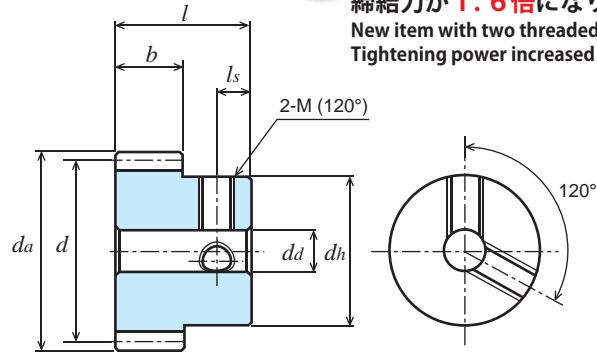

B1形
TYPE B1

S45C 機械構造用炭素鋼 (JIS G 4051)
Material : Carbon Steel (ISO C45)

単位 : mm
Dimensions : mm

商品記号 Catalogue Number	歯数 Number of Teeth z	基準円直径 Reference Diameter d	歯先円直径 Tip Diameter da	形 Type	歯幅 Face Width b	穴径 Bore Diameter da(H7)	ハブ外径 Hub Diameter dh	ハブ長さ Hub Projection lh	全長 Overall Length l	キミぞ Key Way b ₂ × t ₂	ねじ Set Screw		重量 Weight W(g)
											2-M(120°)	ls	
S1S 46A - 0608F	46	φ46	φ48	A1	6	φ 8	-	-	6	-	-	-	75.9
S1S 46A - 1010F	46	φ46	φ48	A1	10	φ10	-	-	10	-	-	-	124.3
S1S 46B - 0608F	46	φ46	φ48	B1	6	φ 8	φ30	10	16	-	-	-	127.5
S1S 46B - 1010F	46	φ46	φ48	B1	10	φ10	φ30	10	20	-	-	-	173.6
S1S 48A - 0608F	48	φ48	φ50	A1	6	φ 8	-	-	6	-	-	-	82.9
S1S 48A = 0610	48	φ48	φ50	A1	6	φ10	-	-	6	3 × 1.4	-	-	81.3
S1S 48A = 0612	48	φ48	φ50	A1	6	φ12	-	-	6	4 × 1.8	-	-	79.6
S1S 48A - 1010F	48	φ48	φ50	A1	10	φ10	-	-	10	-	-	-	135.9
S1S 48A = 1012	48	φ48	φ50	A1	10	φ12	-	-	10	4 × 1.8	-	-	132.6
S1S 48A = 1015	48	φ48	φ50	A1	10	φ15	-	-	10	5 × 2.3	-	-	127.3
S1S 48B - 0608	48	φ48	φ50	B1	6	φ 8	φ24	10	16	-	-	-	114.5
S1S 48B * 0608	48	φ48	φ50	B1	6	φ 8	φ24	10	16	-	2-M4	4	113.2
S1S 48B * 0610	48	φ48	φ50	B1	6	φ10	φ24	10	16	-	2-M5	5	109.1
S1S 48B * 0612	48	φ48	φ50	B1	6	φ12	φ24	10	16	-	2-M5	5	105.0
S1S 48B - 1010	48	φ48	φ50	B1	10	φ10	φ30	10	20	-	-	-	185.3
S1S 48B * 1010	48	φ48	φ50	B1	10	φ10	φ30	10	20	-	2-M5	5	182.7
S1S 48B * 1012	48	φ48	φ50	B1	10	φ12	φ30	10	20	-	2-M5	5	177.5
S1S 48B * 1015	48	φ48	φ50	B1	10	φ15	φ30	10	20	-	2-M5	5	167.9

【=】 (イコール) にはキー材が付いております。【=】: Gear with key way / with key.

【*】 (アスタ) にはセットスクリューが2個付いております。【*】: Gear with two threaded holes / with two set screws.

許容伝達動力表 曲げ強さ (W)

T (N · m)

Allowable transfer capability table (W) Bending Strength

歯数 z	歯幅 b	回転速度 (min ⁻¹) revolution/min							回転速度 (min ⁻¹) revolution/min
		10	100	200	400	800	1,200	1,500	
46	6	14.40	143.98	287.96	575.93	1,011.26	1,346.11	1,623.07	13.74
46	10	24.00	239.97	479.94	959.88	1,685.44	2,243.51	2,705.12	22.91
48	6	0.015(kW)	0.15(kW)	0.30(kW)	0.60(kW)	1.05(kW)	1.40(kW)	1.70(kW)	14.32
48	10	0.025(kW)	0.25(kW)	0.50(kW)	1.01(kW)	1.75(kW)	2.33(kW)	2.83(kW)	23.87

The above numerical values are equivalent to JGMA formulas as reference only.

動力の換算式は P26 をご参照ください。Please refer to the conversion formula of power on page P26.

平歯車

SPUR GEARS

モジュール
MODULE

1

圧力角 20° (並歯) 歯数 50

20° PRESSURE ANGLE FULL DEPTH TOOTH Z 50

JIS B 1702-1 (ISO) 8級 (高周波焼入品: 9級)
System of accuracy: JIS B 1702-1(ISO) class 8
(Induction hardened products: class 9)



御注文には必ず“フルネームで商品記号”を明記してください。
Please refer to the catalogue reference while ordering.

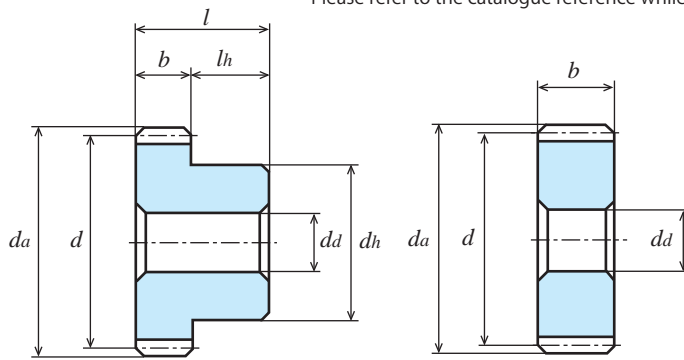

B1形
TYPE B1

A1形
TYPE A1

S45C 機械構造用炭素鋼 (JIS G 4051)

Material: Carbon Steel (ISO C45)

単位: mm
Dimensions: mm

商品記号 Catalogue Number	歯数 Number of Teeth z	基準円直径 Reference Diameter d	歯先円直径 Tip Diameter da	形 Type	歯幅 Face Width b	穴径 Bore Diameter dd(H7)	ハブ外径 Hub Diameter dh	ハブ長さ Hub Projection lh	全長 Overall Length l	キミぞ Key Way b ₂ × t ₂	ねじ Set Screw		重量 Weight W(g)
											2-M(120°)	ls	
S1S 50A - 0610F	50	φ50	φ52	A1	6	φ10	-	-	6	-	-	-	88.8
S1S 50A = 0612	50	φ50	φ52	A1	6	φ12	-	-	6	4 × 1.8	-	-	86.8
S1S 50A - 1008F	50	φ50	φ52	A1	10	φ8	-	-	10	-	-	-	150.2
S1S 50A = 1010	50	φ50	φ52	A1	10	φ10	-	-	10	3 × 1.4	-	-	147.6
S1S 50A = 1012	50	φ50	φ52	A1	10	φ12	-	-	10	4 × 1.8	-	-	144.7
S1S 50A = 1015	50	φ50	φ52	A1	10	φ15	-	-	10	5 × 2.3	-	-	139.4
S1S 50B - 0608	50	φ50	φ52	B1	6	φ8	φ24	10	16	-	-	-	121.8
S1S 50B * 0608	50	φ50	φ52	B1	6	φ8	φ24	10	16	-	2-M4	4	120.4
S1S 50B * 0610	50	φ50	φ52	B1	6	φ10	φ24	10	16	-	2-M5	5	116.4
S1S 50B * 0612	50	φ50	φ52	B1	6	φ12	φ24	10	16	-	2-M5	5	112.3
● S1S50BF - 1008	50	φ50	φ52	B1	10	φ8	φ35	10	20	-	-	-	221.0
● S1S50B - 1008H	50	φ50	φ52	B1	10	φ8(H※)	φ35	10	20	-	-	-	221.0
S1S 50B - 1010	50	φ50	φ52	B1	10	φ10	φ30	10	20	-	-	-	197.4
S1S 50B * 1010	50	φ50	φ52	B1	10	φ10	φ30	10	20	-	2-M5	5	194.8
S1S 50B * 1012	50	φ50	φ52	B1	10	φ12	φ30	10	20	-	2-M5	5	189.6
S1S 50B * 1015	50	φ50	φ52	B1	10	φ15	φ30	10	20	-	2-M5	5	180.0

●の商品は新商品です。Products with ● marks are new item.

【=】(イコール)にはキー材が付いております。【=】: Gear with key way / with key.

【*】(アスタ)にはセットスクリーが2個付いております。【*】: Gear with two threaded holes / with two set screws.

カタログ記号の末尾に【H】を付した商品は歯部高周波焼入済です。Gear tooth surface completed with induction hardening, Hardness HRC47 to 53.

※
歯部高周波焼入後の穴修正は行っていません。Bore correcting after induction hardening is not completed.

追加加工の際は、追加加工時の注意をご参照ください。Please refer to Precaution for additional process when additional process.

許容伝達動力表 曲げ強さ (kW)

Allowable transfer capability table (kW) Bending Strength

歯数 z	歯幅 b	焼入 H	回転速度 (min ⁻¹) revolution/min						
			10	100	200	400	800	1,200	1,500
50	6	-	0.015	0.15	0.31	0.63	1.09	1.46	1.77
50	10	-	0.026	0.260	0.530	1.050	1.820	2.430	2.950
50	10	○	0.028	0.281	0.562	1.116	1.955	2.635	3.205

The above references are JGMA standard.

動力の換算式はP26をご参照ください。Please refer to the conversion formula of power on page P26.

許容伝達動力表 歯面強さ (kW)

Allowable transfer capability table (kW) Surface Durability

回転速度 (min ⁻¹) revolution/min						
10	100	200	400	800	1,200	1,500
-	-	-	-	-	-	-
0.002	0.020	0.050	0.090	0.160	0.220	0.270
0.010	0.109	0.226	0.462	0.835	1.145	1.407

目次
CONTENTS
インフォメーション
INFORMATION
ギヤボックス
GEAR BOXES
ノーマンバックスパーギヤ
ANTI BACKLASH SPUR GEARS
歯研研歯車
GROUND SPUR GEARS
歯研研歯車
SPUR GEARS
内歯車
INTERNAL GEARS
歯研研歯車
GROUND RACKS
ラック
RACKS
（ハ）カハ・ス・シ・ユキ
HELICAL GEARS AND SCREW GEARS
ワーム・ワームホイール
WORMS AND WORM WHEELS
かさ歯車
BEVEL GEARS
スプロケット
SPROCKETS
技術データ
REFERENCE DATA

平歯車

SPUR GEARS

モジュール
MODULE

1

圧力角 20° (並歯) 歯数 52 ~ 55
20° PRESSURE ANGLE FULL DEPTH TOOTH Z 52 to Z 55

JIS B 1702-1 (ISO) 8 級
System of accuracy : JIS B 1702-1(ISO) class 8

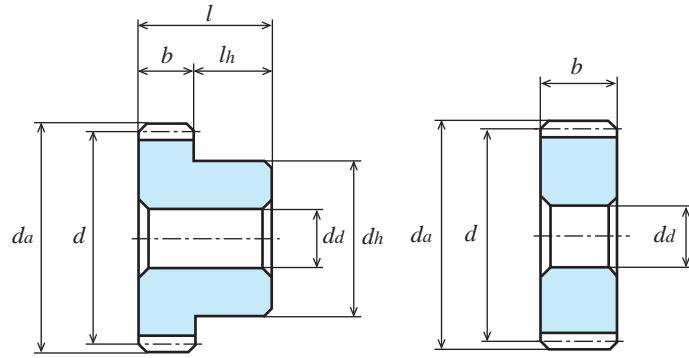

B1形
TYPE B1

A1形
TYPE A1

S45C 機械構造用炭素鋼 (JIS G 4051)

Material : Carbon Steel (ISO C45)

単位 : mm
Dimensions : mm

商品記号 Catalogue Number	歯数 Number of Teeth <i>z</i>	基準円直径 Reference Diameter <i>d</i>	歯先円直径 Tip Diameter <i>da</i>	形 Type	歯幅 Face Width <i>b</i>	穴径 Bore Diameter <i>da</i> (H7)	ハブ外径 Hub Diameter <i>dh</i>	ハブ長さ Hub Projection <i>lh</i>	全長 Overall Length <i>l</i>	キーマゾ Key Way <i>b₂ × t₂</i>	ねじ Set Screw		重量 Weight <i>W</i> (g)
											<i>M</i>	<i>l_s</i>	
S1S 52A - 0610F	52	φ52	φ54	A1	6	φ10	-	-	6	-	-	-	96.3
S1S 52A - 1010F	52	φ52	φ54	A1	10	φ10	-	-	10	-	-	-	160.5
S1S 52B - 0610F	52	φ52	φ54	B1	6	φ10	φ40	10	16	-	-	-	188.8
S1S 52B - 1010F	52	φ52	φ54	B1	10	φ10	φ46	10	20	-	-	-	284.8
S1S 54A - 0610F	54	φ54	φ56	A1	6	φ10	-	-	6	-	-	-	104.2
S1S 54A - 1010F	54	φ54	φ56	A1	10	φ10	-	-	10	-	-	-	173.6
S1S 54B - 0610F	54	φ54	φ56	B1	6	φ10	φ40	10	16	-	-	-	196.7
S1S 54B - 1010F	54	φ54	φ56	B1	10	φ10	φ46	10	20	-	-	-	297.9
S1S 55A - 0610F	55	φ55	φ57	A1	6	φ10	-	-	6	-	-	-	108.2
S1S 55A - 1010F	55	φ55	φ57	A1	10	φ10	-	-	10	-	-	-	180.3
S1S 55B - 0610F	55	φ55	φ57	B1	6	φ10	φ40	10	16	-	-	-	200.7
S1S 55B - 1010F	55	φ55	φ57	B1	10	φ10	φ46	10	20	-	-	-	304.6

許容伝達動力表 曲げ強さ (kW)

Allowable transfer capability table (kW) Bending Strength

歯数 <i>z</i>	歯幅 <i>b</i>	回転速度 (min ⁻¹) revolution/min							回転速度 (min ⁻¹) revolution/min
		10	100	200	400	800	1,200	1,500	
52	6	0.016	0.16	0.33	0.66	1.13	1.53	1.85	15.27
52	10	0.027	0.27	0.55	1.10	1.89	2.55	3.09	25.78
54	6	0.017	0.17	0.35	0.68	1.17	1.59	1.93	16.23
54	10	0.029	0.29	0.58	1.14	1.96	2.65	3.21	27.69
55	6	0.017	0.17	0.35	0.70	1.20	1.62	1.96	16.23
55	10	0.029	0.29	0.59	1.16	2.00	2.71	3.28	27.69

The above numerical values are equivalent to JGMA formulas as reference only.

動力の換算式は P26 をご参照ください。Please refer to the conversion formula of power on page P26.

JIS B 1702-1 (ISO) 8 級
System of accuracy : JIS B 1702-1(ISO) class 8



御注文には必ず“フルネームで商品記号”を明記してください。

Please refer to the catalogue reference while ordering.

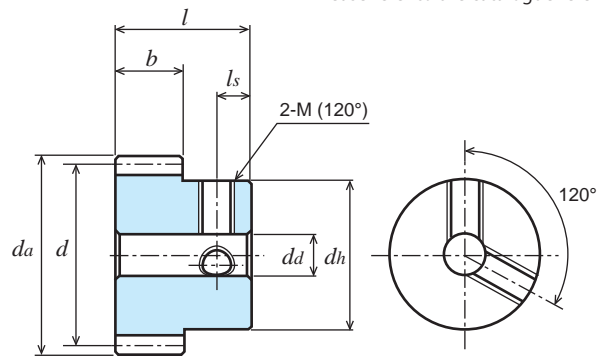

B1形
TYPE B1

S45C 機械構造用炭素鋼 (JIS G 4051)

Material : Carbon Steel (ISO C45)

単位 : mm
Dimensions : mm

商品記号 Catalogue Number	歯数 Number of Teeth z	基準円直径 Reference Diameter d	歯先円直径 Tip Diameter da	形 Type	歯幅 Face Width b	穴径 Bore Diameter dd(H7)	ハブ外径 Hub Diameter dh	ハブ長さ Hub Projection lh	全長 Overall Length l	キミぞ Key Way b ₂ × t ₂	ねじ Set Screw		重量 Weight W(g)
											2-M(120°)	ls	
S1S 56A - 0610F	56	φ56	φ58	A1	6	φ10	-	-	6	-	-	-	112.3
S1S 56A = 0612	56	φ56	φ58	A1	6	φ12	-	-	6	4 × 1.8	-	-	110.3
S1S 56A - 1010F	56	φ56	φ58	A1	10	φ10	-	-	10	-	-	-	187.2
S1S 56A = 1012	56	φ56	φ58	A1	10	φ12	-	-	10	4 × 1.8	-	-	183.9
S1S 56A = 1015	56	φ56	φ58	A1	10	φ15	-	-	10	5 × 2.3	-	-	178.6
S1S 56B - 0610	56	φ56	φ58	B1	6	φ10	φ24	10	16	-	-	-	141.7
S1S 56B * 0610	56	φ56	φ58	B1	6	φ10	φ24	10	16	-	2-M5	5	139.9
S1S 56B * 0612	56	φ56	φ58	B1	6	φ12	φ24	10	16	-	2-M5	5	135.8
S1S 56B - 1010	56	φ56	φ58	B1	10	φ10	φ30	10	20	-	-	-	236.7
S1S 56B * 1010	56	φ56	φ58	B1	10	φ10	φ30	10	20	-	2-M5	5	234.0
S1S 56B * 1012	56	φ56	φ58	B1	10	φ12	φ30	10	20	-	2-M5	5	228.9
S1S 56B * 1015	56	φ56	φ58	B1	10	φ15	φ30	10	20	-	2-M5	5	219.3
S1S 58A - 0610F	58	φ58	φ60	A1	6	φ10	-	-	6	-	-	-	114.6
S1S 58A - 1010F	58	φ58	φ60	A1	10	φ10	-	-	10	-	-	-	195.1
S1S 58B - 0610F	58	φ58	φ60	B1	6	φ10	φ40	10	16	-	-	-	213.2
S1S 58B - 1010F	58	φ58	φ60	B1	10	φ10	φ50	10	20	-	-	-	361.5

【=】(イコール)にはキー材が付いております。【=】: Gear with key way / with key.

【*】(アスタ)にはセットスクリューが2個付いております。【*】: Gear with two threaded holes / with two set screws.

許容伝達動力表 曲げ強さ (kW)

Allowable transfer capability table (kW) Bending Strength

歯数 z	歯幅 b	回転速度 (min ⁻¹) revolution/min							回転速度 (min ⁻¹) revolution/min
		10	100	200	400	800	1,200	1,500	
56	6	0.018	0.18	0.36	0.71	1.22	1.65	2.00	100
56	10	0.030	0.30	0.61	1.19	2.03	2.76	3.34	17.18
58	6	0.019	0.19	0.38	0.74	1.25	1.72	2.08	28.64
58	10	0.031	0.31	0.63	1.23	2.09	2.87	3.47	18.14
									29.60

KG 規格は“並幅”(軽荷重用)と“広幅”(重荷重用)があります。ご用途に応じてお選び下さい。

KG STOCK GEARS has Wide-face width for Heavy load, and Standard-face width for Light load.

You are able to multiple choices for your suitable design from our wide range.

The above numerical values are equivalent to JGMA formulas as reference only.

動力の換算式は P26 をご参照ください。Please refer to the conversion formula of power on page P26.

平歯車 SPUR GEARS

モジュール
MODULE

1

圧力角 20° (並歯) 歯数 60

20° PRESSURE ANGLE FULL DEPTH TOOTH Z 60

JIS B 1702-1 (ISO) 8 級 (高周波焼入品 : 9 級)
System of accuracy : JIS B 1702-1(ISO) class 8
(Induction hardened products : class 9)



New **ねじを2箇所 (120°配) にしました。**
締結力が1.6倍になりました。
New item with two threaded holes (120°)
Tightening power increased by 1.6 times.

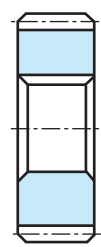

A1形
TYPE A1

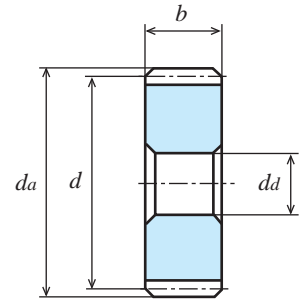
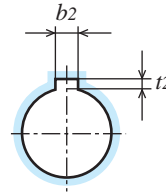

A1形
TYPE A1

S45C 機械構造用炭素鋼 (JIS G 4051)
Material : Carbon Steel (ISO C45)

単位 : mm
Dimensions : mm

商品記号 Catalogue Number	歯数 Number of Teeth z	基準円直径 Reference Diameter d	歯先円直径 Tip Diameter da	形 Type	歯幅 Face Width b	穴径 Bore Diameter da(H7)	ハブ外径 Hub Diameter dh	ハブ長さ Hub Projection lh	全長 Overall Length l	キミぞ Key Way b ₂ × t ₂	ねじ Set Screw		重量 Weight W(g)
											2-M(120°)	ls	
S1S 60A - 0610F	60	φ60	φ62	A1	6	φ10	-	-	6	-	-	-	129.5
S1S 60A = 0612	60	φ60	φ62	A1	6	φ12	-	-	6	4 × 1.8	-	-	127.5
S1S 60A - 1010F	60	φ60	φ62	A1	10	φ10	-	-	10	-	-	-	215.8
S1S 60A = 1010	60	φ60	φ62	A1	10	φ10	-	-	10	3 × 1.4	-	-	215.5
S1S 60A = 1012	60	φ60	φ62	A1	10	φ12	-	-	10	4 × 1.8	-	-	212.5
S1S 60A = 1015	60	φ60	φ62	A1	10	φ15	-	-	10	5 × 2.3	-	-	207.2
S1S 60B - 0610	60	φ60	φ62	B1	6	φ10	φ30	10	16	-	-	-	178.9
S1S 60B * 0610	60	φ60	φ62	B1	6	φ10	φ30	10	16	-	2-M5	5	176.3
S1S 60B * 0612	60	φ60	φ62	B1	6	φ12	φ30	10	16	-	2-M5	5	172.2
S1S 60B * 0615	60	φ60	φ62	B1	6	φ15	φ30	10	16	-	2-M5	5	164.6
S1S 60BF - 1008	60	φ60	φ62	B1	10	φ8	φ42	10	20	-	-	-	321.9
S1S 60B - 1008H	60	φ60	φ62	B1	10	φ8(H※)	φ42	10	20	-	-	-	321.9
S1S 60B - 1010	60	φ60	φ62	B1	10	φ10	φ30	10	20	-	-	-	265.3
S1S 60B * 1010	60	φ60	φ62	B1	10	φ10	φ30	10	20	-	2-M5	5	262.7
S1S 60B * 1012	60	φ60	φ62	B1	10	φ12	φ30	10	20	-	2-M5	5	257.5
S1S 60B * 1015	60	φ60	φ62	B1	10	φ15	φ30	10	20	-	2-M5	5	247.9

●の商品は新商品です。Products with ● marks are new item.

【=】(イコール)にはキー材が付いております。【=】: Gear with key way / with key.

【*】(アスタ)にはセットスクリーが2個付いております。【*】: Gear with two threaded holes / with two set screws.

カタログ記号の末尾に【H】を付した商品は歯部高周波焼入済です。Gear tooth surface completed with induction hardening, Hardness HRC47 to 53.

※
歯部高周波焼入後の穴修正は行っていません。Bore correcting after induction hardening is not completed.

追加加工の際は、追加加工時の注意をご参照ください。Please refer to Precaution for additional process when additional process.

許容伝達動力表 曲げ強さ (kW)

Allowable transfer capability table (kW) Bending Strength

歯数 z	歯幅 b	焼入 H	回転速度 (min ⁻¹) revolution/min						
			10	100	200	400	800	1,200	1,500
60	6	-	0.019	0.19	0.39	0.76	1.29	1.78	2.15
60	10	-	0.033	0.330	0.660	1.270	2.150	2.960	3.570
60	10	○	0.035	0.350	0.700	1.353	2.321	3.212	3.888

The above numerical values are equivalent to JGMA formulas as reference only.

動力の換算式はP26をご参照ください。Please refer to the conversion formula of power on page P26.

許容伝達動力表 歯面強さ (kW)

Allowable transfer capability table (kW) Surface Durability

回転速度 (min ⁻¹) revolution/min						
10	100	200	400	800	1,200	1,500
-	-	-	-	-	-	-
0.003	0.030	0.070	0.130	0.230	0.320	0.400
0.015	0.160	0.331	0.659	1.165	1.641	2.006

JIS B 1702-1 (ISO) 8 級
System of accuracy : JIS B 1702-1(ISO) class 8



御注文には必ず“フルネームで商品記号”を明記してください。

Please refer to the catalogue reference while ordering.

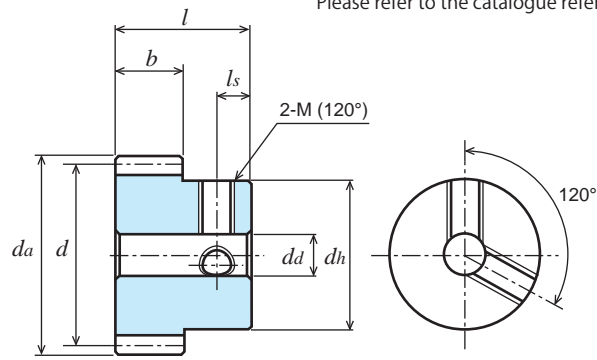

B1形
TYPE B1

S45C 機械構造用炭素鋼 (JIS G 4051)

Material : Carbon Steel (ISO C45)

単位 : mm
Dimensions : mm

商品記号 Catalogue Number	歯数 Number of Teeth z	基準円直径 Reference Diameter d	歯先円直径 Tip Diameter da	形 Type	歯幅 Face Width b	穴径 Bore Diameter da(H7)	ハブ外径 Hub Diameter dh	ハブ長さ Hub Projection lh	全長 Overall Length l	キミぞ Key Way b ₂ × t ₂	ねじ Set Screw		重量 Weight W(g)
											2-M(120°)	ls	
S1S 62A - 0610F	62	φ62	φ64	A1	6	φ10	-	-	6	-	-	-	138.5
S1S 62A - 1010F	62	φ62	φ64	A1	10	φ10	-	-	10	-	-	-	230.8
S1S 62B - 0610F	62	φ62	φ64	B1	6	φ10	φ40	10	16	-	-	-	231.0
S1S 62B - 1010F	62	φ62	φ64	B1	10	φ10	φ50	10	20	-	-	-	378.8
S1S 64A - 0610F	64	φ64	φ66	A1	6	φ10	-	-	6	-	-	-	147.8
S1S 64A = 0612	64	φ64	φ66	A1	6	φ12	-	-	6	4 × 1.8	-	-	145.9
S1S 64A - 1010F	64	φ64	φ66	A1	10	φ10	-	-	10	-	-	-	246.4
S1S 64A = 1012	64	φ64	φ66	A1	10	φ12	-	-	10	4 × 1.8	-	-	243.1
S1S 64A = 1015	64	φ64	φ66	A1	10	φ15	-	-	10	5 × 2.3	-	-	237.8
S1S 64B - 0610	64	φ64	φ66	B1	6	φ10	φ30	10	16	-	-	-	177.3
S1S 64B * 0610	64	φ64	φ66	B1	6	φ10	φ30	10	16	-	2-M5	5	175.5
S1S 64B * 0612	64	φ64	φ66	B1	6	φ12	φ30	10	16	-	2-M5	5	171.4
S1S 64B - 1010	64	φ64	φ66	B1	10	φ10	φ30	10	20	-	-	-	295.9
S1S 64B * 1010	64	φ64	φ66	B1	10	φ10	φ30	10	20	-	2-M5	5	293.3
S1S 64B * 1012	64	φ64	φ66	B1	10	φ12	φ30	10	20	-	2-M5	5	288.1
S1S 64B * 1015	64	φ64	φ66	B1	10	φ15	φ30	10	20	-	2-M5	5	278.5

[=] (イコール)にはキー材が付いております。 [=] : Gear with key way / with key.

[*] (アスタ)にはセットスクリューが2個付いております。 [*] : Gear with two threaded holes / with two set screws.

許容伝達動力表 曲げ強さ (kW)

Allowable transfer capability table (kW) Bending Strength

歯数 z	歯幅 b	回転速度 (min ⁻¹) revolution/min							回転速度 (min ⁻¹) revolution/min
		10	100	200	400	800	1,200	1,500	
62	6	0.020	0.20	0.41	0.79	1.33	1.84	2.22	100
62	10	0.034	0.34	0.69	1.32	2.22	3.08	3.71	19.09
64	6	0.021	0.21	0.43	0.81	1.37	1.91	2.30	100
64	10	0.035	0.35	0.71	1.36	2.29	3.18	3.83	19.09

KG 規格は“並幅” (軽荷重用) と“広幅” (重荷重用) があります。ご用途に応じてお選び下さい。

KG STOCK GEARS has Wide-face width for Heavy load, and Standard-face width for Light load.

You are able to multiple choices for your suitable design from our wide range.

The above numerical values are equivalent to JGMA formulas as reference only.

動力の換算式は P26 をご参照ください。 Please refer to the conversion formula of power on page P26.

平歯車

SPUR GEARS

モジュール
MODULE

1

圧力角 20° (並歯) 歯数 65 ~ 70

20° PRESSURE ANGLE FULL DEPTH TOOTH Z 65 to Z 70

JIS B 1702-1 (ISO) 8級 (高周波焼入品: 9級)
System of accuracy: JIS B 1702-1(ISO) class 8
(Induction hardened products: class 9)

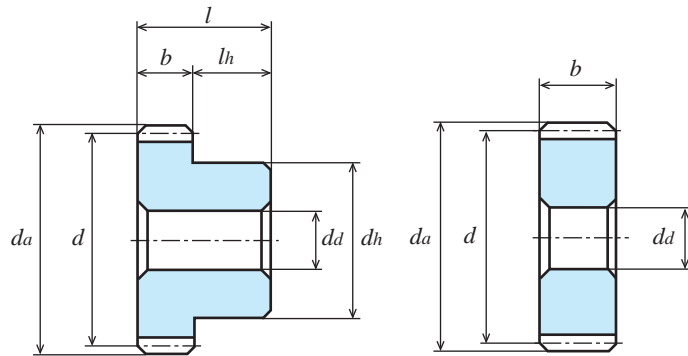

B1形
TYPE B1

A1形
TYPE A1

S45C 機械構造用炭素鋼 (JIS G 4051)

Material: Carbon Steel (ISO C45)

単位: mm
Dimensions: mm

商品記号 Catalogue Number	歯数 Number of Teeth z	基準円直径 Reference Diameter d	歯先円直径 Tip Diameter da	形 Type	歯幅 Face Width b	穴径 Bore Diameter da(H7)	ハブ外径 Hub Diameter dh	ハブ長さ Hub Projection lh	全長 Overall Length l	キミぞ Key Way b ₂ × t ₂	ねじ Set Screw		重量 Weight W(g)
											M	ls	
S1S 65A - 0610F	65	φ65	φ67	A1	6	φ10	-	-	6	-	-	-	152.6
S1S 65A - 1010F	65	φ65	φ67	A1	10	φ10	-	-	10	-	-	-	254.3
S1S 65B - 0610F	65	φ65	φ67	B1	6	φ10	φ40	10	16	-	-	-	245.1
S1S 65B - 1010F	65	φ65	φ67	B1	10	φ10	φ50	10	20	-	-	-	402.3
S1S 66A - 0610F	66	φ66	φ68	A1	6	φ10	-	-	6	-	-	-	157.4
S1S 66A - 1010F	66	φ66	φ68	A1	10	φ10	-	-	10	-	-	-	262.4
S1S 66B - 0610F	66	φ66	φ68	B1	6	φ10	φ40	10	16	-	-	-	249.9
S1S 66B - 1010F	66	φ66	φ68	B1	10	φ10	φ50	10	20	-	-	-	410.4
S1S 68A - 0610F	68	φ68	φ70	A1	6	φ10	-	-	6	-	-	-	167.4
S1S 68A - 1010F	68	φ68	φ70	A1	10	φ10	-	-	10	-	-	-	278.9
S1S 68B - 0610F	68	φ68	φ70	B1	6	φ10	φ40	10	16	-	-	-	259.8
S1S 68B - 1010F	68	φ68	φ70	B1	10	φ10	φ50	10	20	-	-	-	426.9
S1S 70A - 0610F	70	φ70	φ72	A1	6	φ10	-	-	6	-	-	-	177.6
S1S 70A - 1010F	70	φ70	φ72	A1	10	φ10	-	-	10	-	-	-	295.9
S1S 70B - 0610F	70	φ70	φ72	B1	6	φ10	φ40	10	16	-	-	-	270.0
S1S 70B - 1010F	70	φ70	φ72	B1	10	φ10	φ50	10	20	-	-	-	442.9
S1S 70BF - 1010	70	φ70	φ72	B1	10	φ10	φ55	10	20	-	-	-	442.9
S1S 70B - 1010H	70	φ70	φ72	B1	10	φ10(H※)	φ55	10	20	-	-	-	442.9

●の商品は新商品です。Products with ● marks are new item.

■の商品は仕様変更商品です。ご購入の際は寸法にご注意ください。

【=】(イコール)にはキー材が付いております。【-】: Gear with key way / with key.

Products with ■ marks are the changed specification.

【*】(アスタ)にはセットスクリューが2個付いております。

Beware of each dimension when choosing this product.

カタログ記号の末尾に【H】を付した商品は歯部高周波焼入済です。Gear tooth surface completed with induction hardening, Hardness HRC47 to 53.

※
歯部高周波焼入後の穴修正は行っていません。Bore correcting after induction hardening is not completed.

追加加工の際は、追加加工時の注意をご参照ください。Please refer to Precaution for additional process when additional process.

許容伝達動力表 曲げ強さ (kW)

Allowable transfer capability table (kW) Bending Strength

歯数 z	歯幅 b	焼入 H	回転速度 (min ⁻¹) revolution/min						
			10	100	200	400	800	1,200	1,500
65	6	-	0.021	0.21	0.43	0.83	1.39	1.94	2.34
65	10	-	0.036	0.36	0.73	1.38	2.32	3.23	3.90
66	6	-	0.022	0.22	0.44	0.84	1.41	1.97	2.38
66	10	-	0.037	0.37	0.74	1.40	2.35	3.28	3.96
68	6	-	0.023	0.23	0.46	0.86	1.44	2.03	2.45
68	10	-	0.038	0.38	0.77	1.44	2.41	3.38	4.09
70	6	-	0.023	0.23	0.47	0.94	1.48	2.09	2.53
70	10	-	0.040	0.400	0.790	1.480	2.460	3.470	4.190
70	10	○	0.042	0.420	0.840	1.579	2.658	3.770	4.618

The above references are JGMA standard.

動力の換算式はP26をご参照ください。Please refer to the conversion formula of power on page P26.

許容伝達動力表 歯面強さ (kW)

Allowable transfer capability table (kW) Surface Durability

回転速度 (min ⁻¹) revolution/min						
10	100	200	400	800	1,200	1,500
-	-	-	-	-	-	-
-	-	-	-	-	-	-
-	-	-	-	-	-	-
-	-	-	-	-	-	-
-	-	-	-	-	-	-
-	-	-	-	-	-	-
0.005	0.050	0.090	0.170	0.300	0.440	0.550
0.020	0.222	0.457	0.886	1.537	2.219	2.745

JIS B 1702-1 (ISO) 8 級
System of accuracy : JIS B 1702-1(ISO) class 8



御注文には必ず“フルネームで商品記号”を明記してください。

Please refer to the catalogue reference while ordering.

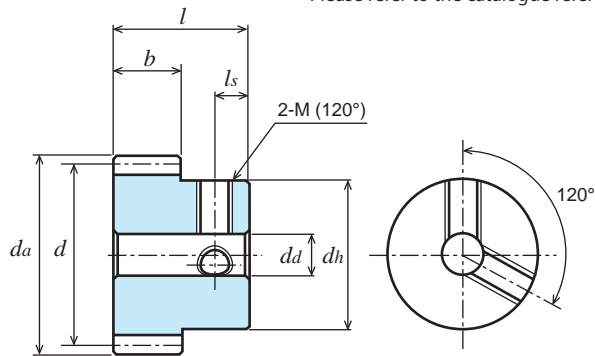

B1形
TYPE B1

S45C 機械構造用炭素鋼 (JIS G 4051)

Material : Carbon Steel (ISO C45)

単位 : mm
Dimensions : mm

商品記号 Catalogue Number	歯数 Number of Teeth z	基準円直径 Reference Diameter d	歯先円直径 Tip Diameter da	形 Type	歯幅 Face Width b	穴径 Bore Diameter da(H7)	ハブ外径 Hub Diameter dh	ハブ長さ Hub Projection lh	全長 Overall Length l	キミぞ Key Way b ₂ × t ₂	ねじ Set Screw		重量 Weight W(g)
											2-M(120°)	ls	
S1S 72A - 0610F	72	φ72	φ74	A1	6	φ10	-	-	6	-	-	-	188.1
S1S 72A = 0612	72	φ72	φ74	A1	6	φ12	-	-	6	4 × 1.8	-	-	186.1
S1S 72A - 1010F	72	φ72	φ74	A1	10	φ10	-	-	10	-	-	-	313.4
S1S 72A = 1012	72	φ72	φ74	A1	10	φ12	-	-	10	4 × 1.8	-	-	310.2
S1S 72A = 1015	72	φ72	φ74	A1	10	φ15	-	-	10	5 × 2.3	-	-	304.8
S1S 72B - 0610	72	φ72	φ74	B1	6	φ10	φ30	10	16	-	-	-	217.6
S1S 72B * 0610	72	φ72	φ74	B1	6	φ10	φ30	10	16	-	2-M5	5	215.7
S1S 72B * 0612	72	φ72	φ74	B1	6	φ12	φ30	10	16	-	2-M5	5	211.6
S1S 72B - 1010	72	φ72	φ74	B1	10	φ10	φ30	10	20	-	-	-	363.0
S1S 72B * 1010	72	φ72	φ74	B1	10	φ10	φ30	10	20	-	2-M5	5	360.4
S1S 72B * 1012	72	φ72	φ74	B1	10	φ12	φ30	10	20	-	2-M5	5	355.2
S1S 72B * 1015	72	φ72	φ74	B1	10	φ15	φ30	10	20	-	2-M5	5	345.6
S1S 75A - 0610F	75	φ75	φ77	A1	6	φ10	-	-	6	-	-	-	204.4
S1S 75A - 1010F	75	φ75	φ77	A1	10	φ10	-	-	10	-	-	-	340.6
S1S 75B - 0610F	75	φ75	φ77	B1	6	φ10	φ40	10	16	-	-	-	296.9
S1S 75B - 1010F	75	φ75	φ77	B1	10	φ10	φ50	10	20	-	-	-	488.6

[=] (イコール)にはキー材が付いております。 [=] : Gear with key way / with key.

[*] (アスタ)にはセットスクリューが2個付いております。 [*] : Gear with two threaded holes / with two set screws.

許容伝達動力表 曲げ強さ (kW)

Allowable transfer capability table (kW) Bending Strength

歯数 z	歯幅 b	回転速度 (min ⁻¹) revolution/min							回転速度 (min ⁻¹) revolution/min	
		10	100	200	400	800	1,200	1,500		
72	6	0.024	0.24	0.49	0.91	1.52	2.15	2.60	100	22.91
72	10	0.041	0.41	0.82	1.53	2.53	3.59	4.34	100	39.15
75	6	0.025	0.25	0.51	0.95	1.58	2.24	2.72	100	23.87
75	10	0.043	0.43	0.86	1.59	2.64	3.74	4.53	100	41.06

KG 規格は (JIS 1721) “並幅” (軽荷重用) と “広幅” (重荷重用) があります。ご用途に応じてお選び下さい。

KG STOCK GEARS has Wide-face width for Heavy load, and Standard-face width for Light load.

You are able to multiple choices for your suitable design from our wide range.

The above numerical values are equivalent to JGMA formulas as reference only.

動力の換算式は P26 をご参照ください。 Please refer to the conversion formula of power on page P26.

平歯車 SPUR GEARS

モジュール
MODULE

1

圧力角 20° (並歯) 歯数 80
20° PRESSURE ANGLE FULL DEPTH TOOTH Z 80

JIS B 1702-1 (ISO) 8級 (高周波焼入品: 9級)
System of accuracy: JIS B 1702-1(ISO) class 8
(Induction hardened products: class 9)



New **ねじを2箇所 (120°配) にしました。**
締結力が1.6倍になりました。
New item with two threaded holes (120°)
Tightening power increased by 1.6 times.

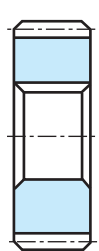

A1形
TYPE A1

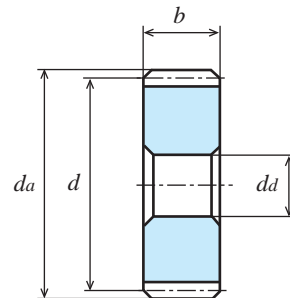
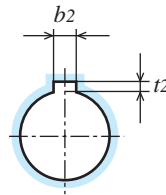

A1形
TYPE A1

S45C 機械構造用炭素鋼 (JIS G 4051) Material: Carbon Steel (ISO C45)

単位: mm
Dimensions: mm

商品記号 Catalogue Number	歯数 Number of Teeth z	基準円直径 Reference Diameter d	歯先円直径 Tip Diameter da	形 Type	歯幅 Face Width b	穴径 Bore Diameter da(H7)	ハブ外径 Hub Diameter dh	ハブ長さ Hub Projection lh	全長 Overall Length l	キミぞ Key Way b ₂ × t ₂	ねじ Set Screw		重量 Weight W(g)
											2-M(120°)	ls	
S1S 80A - 0610F	80	φ80	φ82	A1	6	φ10	-	-	6	-	-	-	233.1
S1S 80A = 0612	80	φ80	φ82	A1	6	φ12	-	-	6	4 × 1.8	-	-	231.1
S1S 80A = 0615	80	φ80	φ82	A1	6	φ15	-	-	6	5 × 2.3	-	-	227.9
S1S 80A - 1010F	80	φ80	φ82	A1	10	φ10	-	-	10	-	-	-	388.4
S1S 80A = 1010	80	φ80	φ82	A1	10	φ10	-	-	10	3 × 1.4	-	-	388.1
S1S 80A = 1012	80	φ80	φ82	A1	10	φ12	-	-	10	4 × 1.8	-	-	385.1
S1S 80A = 1015	80	φ80	φ82	A1	10	φ15	-	-	10	5 × 2.3	-	-	379.8
S1S 80A = 1016	80	φ80	φ82	A1	10	φ16	-	-	10	5 × 2.3	-	-	377.9
S1S 80B - 0610	80	φ80	φ82	B1	6	φ10	φ30	10	16	-	-	-	282.6
S1S 80B * 0610	80	φ80	φ82	B1	6	φ10	φ30	10	16	-	2-M5	5	279.9
S1S 80B * 0612	80	φ80	φ82	B1	6	φ12	φ30	10	16	-	2-M5	5	275.9
S1S 80B * 0615	80	φ80	φ82	B1	6	φ15	φ30	10	16	-	2-M5	5	268.3
S1S 80BF - 1010	80	φ80	φ82	B1	10	φ10	φ60	10	20	-	-	-	603.1
S1S 80B - 1010H	80	φ80	φ82	B1	10	φ10(H※)	φ60	10	20	-	-	-	603.1
S1S 80B - 1010	80	φ80	φ82	B1	10	φ10	φ32	10	20	-	-	-	445.7
S1S 80B * 1010	80	φ80	φ82	B1	10	φ10	φ32	10	20	-	2-M5	5	442.8
S1S 80B * 1012	80	φ80	φ82	B1	10	φ12	φ32	10	20	-	2-M5	5	437.6
S1S 80B * 1015	80	φ80	φ82	B1	10	φ15	φ32	10	20	-	2-M5	5	428.0
S1S 80B * 1016	80	φ80	φ82	B1	10	φ16	φ32	10	20	-	2-M5	5	424.3

●の商品は新商品です。Products with ● marks are new item.

■の商品は仕様変更商品です。ご選定の際は寸法にご注意ください。
Products with ■ marks are the changed specification.
Beware of each dimension when choosing this product.

[=] (イコール)にはキマ材が付いております。 [=]: Gear with key way / with key.

[*] (アスタ)にはセットスクリーが2個付いております。 [*]: Gear with two threaded holes / with two set screws.

カタログ記号の末尾に【H】を付した商品は歯部高周波焼入済です。 Gear tooth surface completed with induction hardening, Hardness HRC47 to 53.

※ 歯部高周波焼入後の穴修正は行っていません。 Bore correcting after induction hardening is not completed.

追加加工の際は、追加加工時の注意をご参照ください。 Please refer to Precaution for additional process when additional process.

許容伝達動力表 曲げ強さ (kW)

Allowable transfer capability table (kW) Bending Strength

歯数 z	歯幅 b	焼入 H	回転速度 (min ⁻¹) revolution/min						
			10	100	200	400	800	1,200	1,500
80	6	-	0.027	0.27	0.55	1.01	1.69	2.39	2.90
80	10	-	0.046	0.460	0.920	1.680	2.810	3.960	4.810
80	10	○	0.049	0.490	0.980	1.795	3.043	4.313	5.392

The above numerical values are equivalent to JGMA formulas as reference only.

動力の換算式はP26をご参照ください。 Please refer to the conversion formula of power on page P26.

許容伝達動力表 歯面強さ (kW)

Allowable transfer capability table (kW) Surface Durability

回転速度 (min ⁻¹) revolution/min						
10	100	200	400	800	1,200	1,500
0.006	-	-	-	-	-	-
0.006	0.060	0.120	0.220	0.390	0.580	0.730
0.026	0.293	0.604	1.141	1.993	2.876	3.631

平歯車

SPUR GEARS

モジュール
MODULE

1

圧力角 20° (並歯) 歯数 84 ~ 96

20° PRESSURE ANGLE FULL DEPTH TOOTH Z 84 to Z 96

JIS B 1702-1 (ISO) 8級 (高周波焼入品: 9級)
System of accuracy: JIS B 1702-1(ISO) class 8
(Induction hardened products: class 9)



御注文には必ず“フルネームで商品記号”を明記してください。
Please refer to the catalogue reference while ordering.

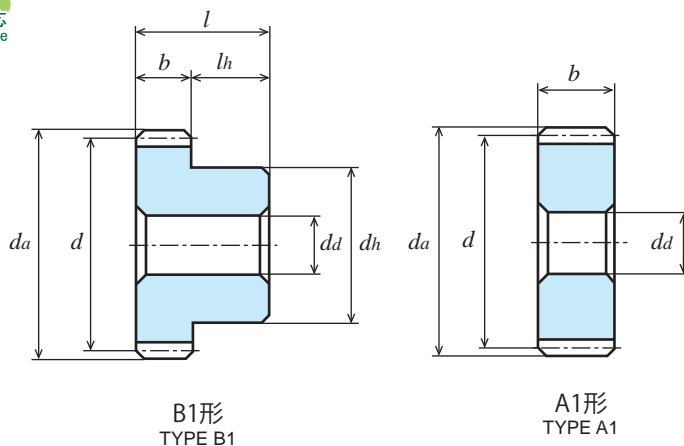

S45C 機械構造用炭素鋼 (JIS G 4051)

Material: Carbon Steel (ISO C45)

単位: mm
Dimensions: mm

商品記号 Catalogue Number	歯数 Number of Teeth z	基準円直径 Reference Diameter d	歯先円直径 Tip Diameter da	形 Type	歯幅 Face Width b	穴径 Bore Diameter da(H7)	ハブ外直径 Hub Diameter dh	ハブ長さ Hub Projection lh	全長 Overall Length l	キミぞ Key Way b ₂ × t ₂	ねじ Set Screw		重量 Weight W(g)
											M	ls	
S1S 84A - 0610F	84	φ84	φ86	A1	6	φ10	-	-	6	-	-	-	257.3
S1S 84A - 1010F	84	φ84	φ86	A1	10	φ10	-	-	10	-	-	-	428.9
S1S 84B - 0610F	84	φ84	φ86	B1	6	φ10	φ50	10	16	-	-	-	405.3
S1S 84B - 1010F	84	φ84	φ86	B1	10	φ10	φ50	10	20	-	-	-	576.8
S1S 85A - 0610F	85	φ85	φ87	A1	6	φ10	-	-	6	-	-	-	263.6
S1S 85A - 1010F	85	φ85	φ87	A1	10	φ10	-	-	10	-	-	-	439.3
S1S 85B - 0610F	85	φ85	φ87	B1	6	φ10	φ50	10	16	-	-	-	411.5
S1S 85B - 1010F	85	φ85	φ87	B1	10	φ10	φ50	10	20	-	-	-	587.3
S1S 90A - 0610F	90	φ90	φ92	A1	6	φ10	-	-	6	-	-	-	295.9
S1S 90A - 1010F	90	φ90	φ92	A1	10	φ10	-	-	10	-	-	-	493.2
S1S 90B - 0610F	90	φ90	φ92	B1	6	φ10	φ50	10	16	-	-	-	443.9
S1S 90B - 1010F	90	φ90	φ92	B1	10	φ10	φ50	10	20	-	-	-	641.2
● S1S 90BF - 1010	90	φ90	φ92	B1	10	φ10	φ65	10	20	-	-	-	746.3
■ S1S 90B - 1010H	90	φ90	φ92	B1	10	φ10(H※)	φ65	10	20	-	-	-	746.3
S1S 96A - 0610F	96	φ96	φ98	A1	6	φ10	-	-	6	-	-	-	337.2
S1S 96A - 1010F	96	φ96	φ98	A1	10	φ10	-	-	10	-	-	-	562.0
S1S 96B - 0610F	96	φ96	φ98	B1	6	φ10	φ50	10	16	-	-	-	485.2
S1S 96B - 1010F	96	φ96	φ98	B1	10	φ10	φ50	10	20	-	-	-	710.0

●の商品は新商品です。Products with ● marks are new item.

■の商品は仕様変更商品です。ご選定の際は寸法にご注意ください。

【=】(イコール)にはキー材が付いております。【=】: Gear with key way / with key.

Products with ■ marks are the changed specification. Beware of each dimension when choosing this product.

【*】(アスタ)にはセットスクリューが2個付いております。

カタログ記号の末尾に【H】を付した商品は歯部高周波焼入済です。Gear tooth surface completed with induction hardening, Hardness HRC47 to 53.

※ 歯部高周波焼入後の穴修正は行っていません。Bore correcting after induction hardening is not completed.

追加加工の際は、追加加工時の注意をご参照ください。Please refer to Precaution for additional process when additional process.

許容伝達動力表 曲げ強さ (kW)

Allowable transfer capability table (kW) Bending Strength

歯数 z	歯幅 b	焼入 H	回転速度 (min ⁻¹) revolution/min						
			10	100	200	400	800	1,200	1,500
84	6		0.029	0.29	0.59	1.06	1.78	2.51	3.04
84	10		0.049	0.49	0.98	1.76	2.96	4.19	5.07
85	6		0.029	0.29	0.59	1.07	1.80	2.54	3.08
85	10		0.049	0.49	0.99	1.78	3.00	4.24	5.13
90	6		0.031	0.31	0.63	1.12	1.90	2.69	3.26
90	10		0.053	0.530	1.060	1.870	3.160	4.460	5.400
90	10	○	0.056	0.560	1.120	1.999	3.427	4.929	6.162
96	6		0.034	0.34	0.68	1.19	2.03	2.87	3.47
96	10		0.057	0.57	1.14	1.99	3.39	4.79	5.78

The above references are JGMA standard.

動力の換算式はP26をご参照ください。Please refer to the conversion formula of power on page P26.

許容伝達動力表 歯面強さ (kW)

Allowable transfer capability table (kW) Surface Durability

回転速度 (min ⁻¹) revolution/min						
10	100	200	400	800	1,200	1,500
-	-	-	-	-	-	-
-	-	-	-	-	-	-
-	-	-	-	-	-	-
-	-	-	-	-	-	-
0.008	0.080	0.160	0.280	0.500	0.740	0.930
0.034	0.375	0.773	1.423	2.514	3.681	4.647
-	-	-	-	-	-	-
-	-	-	-	-	-	-

目次 CONTENTS
インフォメーション INFORMATION
ギヤボックス GEAR BOXES
ノーバッキングバックラッシュギヤ NO BACKLASH SPUR GEARS
歯車 SPUR GEARS
歯車 SPUR GEARS
歯車 SPUR GEARS
内歯車 INTERNAL GEARS
歯車 GROUND RACKS
歯車 RACKS
歯車 HEICAL GEARS AND SCREW GEARS
ワームとワームホイール WORMS AND WORM WHEELS
かみ歯車 BEVEL GEARS
スプロケット SPROCKETS
技術データ REFERENCE DATA

平歯車

SPUR GEARS

モジュール
MODULE

1

圧力角 20° (並歯) 歯数 100

20° PRESSURE ANGLE FULL DEPTH TOOTH Z 100

JIS B 1702-1 (ISO) 8級 (高周波焼入品: 9級)
System of accuracy: JIS B 1702-1(ISO) class 8
(Induction hardened products: class 9)



New **ねじを2箇所 (120°配) にしました。**
締結力が**1.6倍**になりました。
New item with two threaded holes (120°)
Tightening power increased by 1.6 times.

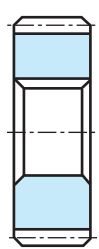

A1形
TYPE A1

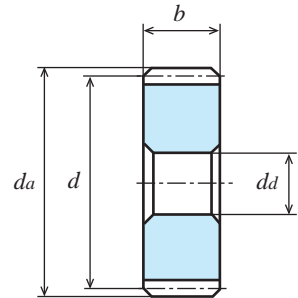
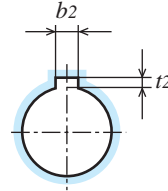

A1形
TYPE A1

S45C 機械構造用炭素鋼 (JIS G 4051)
Material: Carbon Steel (ISO C45)

単位: mm
Dimensions: mm

商品記号 Catalogue Number	歯数 Number of Teeth z	基準円直径 Reference Diameter d	歯先円直径 Tip Diameter da	形 Type	歯幅 Face Width b	穴径 Bore Diameter da(H7)	ハブ外径 Hub Diameter dh	ハブ長さ Hub Projection lh	全長 Overall Length l	キミぞ Key Way b ₂ × t ₂	ねじ Set Screw		重量 Weight W(g)
											2-M(120°)	ls	
S1S 100A - 0610F	100	φ100	φ102	A1	6	φ10	-	-	6	-	-	-	366.2
S1S 100A = 0612	100	φ100	φ102	A1	6	φ12	-	-	6	4 × 1.8	-	-	364.3
S1S 100A = 0615	100	φ100	φ102	A1	6	φ15	-	-	6	5 × 2.3	-	-	361.1
S1S 100A - 1010F	100	φ100	φ102	A1	10	φ10	-	-	10	-	-	-	610.4
S1S 100A = 1010	100	φ100	φ102	A1	10	φ10	-	-	10	3 × 1.4	-	-	610.0
S1S 100A = 1012	100	φ100	φ102	A1	10	φ12	-	-	10	4 × 1.8	-	-	607.1
S1S 100A = 1015	100	φ100	φ102	A1	10	φ15	-	-	10	5 × 2.3	-	-	601.8
S1S 100A = 1016	100	φ100	φ102	A1	10	φ16	-	-	10	5 × 2.3	-	-	599.9
S1S 100A = 1018	100	φ100	φ102	A1	10	φ18	-	-	10	6 × 2.8	-	-	595.2
S1S 100B - 0610	100	φ100	φ102	B1	6	φ10	φ30	10	16	-	-	-	415.8
S1S 100B * 0610	100	φ100	φ102	B1	6	φ10	φ30	10	16	-	2-M5	5	413.2
S1S 100B * 0612	100	φ100	φ102	B1	6	φ12	φ30	10	16	-	2-M5	5	409.1
S1S 100B * 0615	100	φ100	φ102	B1	6	φ15	φ30	10	16	-	2-M5	5	401.5
S1S 100BF - 1010	100	φ100	φ102	B1	10	φ10	φ70	10	20	-	-	-	904.9
S1S 100B - 1010H	100	φ100	φ102	B1	10	φ10(H※)	φ70	10	20	-	-	-	904.9
S1S 100B - 1012	100	φ100	φ102	B1	10	φ12	φ36	10	20	-	-	-	679.1
S1S 100B * 1012	100	φ100	φ102	B1	10	φ12	φ36	10	20	-	2-M5	5	676.0
S1S 100B * 1015	100	φ100	φ102	B1	10	φ15	φ36	10	20	-	2-M5	5	666.4
S1S 100B * 1016	100	φ100	φ102	B1	10	φ16	φ36	10	20	-	2-M5	5	662.7
S1S 100B * 1018	100	φ100	φ102	B1	10	φ18	φ36	10	20	-	2-M5	5	654.6

●の商品は新商品です。Products with ● marks are new item.

【=】(イコール)にはキー材が付いております。【=】: Gear with key way / with key.

【*】(アスタ)にはセットスクリューが2個付いております。【*】: Gear with two threaded holes / with two set screws.

カタログ記号の末尾に【H】を付した商品は歯部高周波焼入済です。Gear tooth surface completed with induction hardening, Hardness HRC47 to 53.

※ 歯部高周波焼入後の穴修正は行っていません。Bore correcting after induction hardening is not completed.

追加加工の際は、追加加工時の注意をご参照ください。Please refer to Precaution for additional process when additional process.

許容伝達動力表 曲げ強さ (kW)

Allowable transfer capability table (kW) Bending Strength

歯数 z	歯幅 b	焼入 H	回転速度 (min ⁻¹) revolution/min						
			10	100	200	400	800	1,200	1,500
100	6	-	0.036	0.36	0.71	1.23	2.11	2.99	3.61
100	10	-	0.060	0.600	1.180	2.040	3.500	4.950	5.970
100	10	○	0.063	0.631	1.254	2.196	3.804	5.552	6.940

The above references are JGMA standard.

動力の換算式は P26 をご参照ください。Please refer to the conversion formula of power on page P26.

許容伝達動力表 歯面強さ (kW)

Allowable transfer capability table (kW) Surface Durability

回転速度 (min ⁻¹) revolution/min						
10	100	200	400	800	1,200	1,500
-	-	-	-	-	-	-
0.010	0.100	0.190	0.340	0.620	0.930	1.160
0.042	0.468	0.958	1.730	3.090	4.590	5.794

JIS B 1702-1 (ISO) 8 級
System of accuracy : JIS B 1702-1(ISO) class 8



御注文には必ず “フルネームで商品記号” を明記してください。
Please refer to the catalogue reference while ordering.

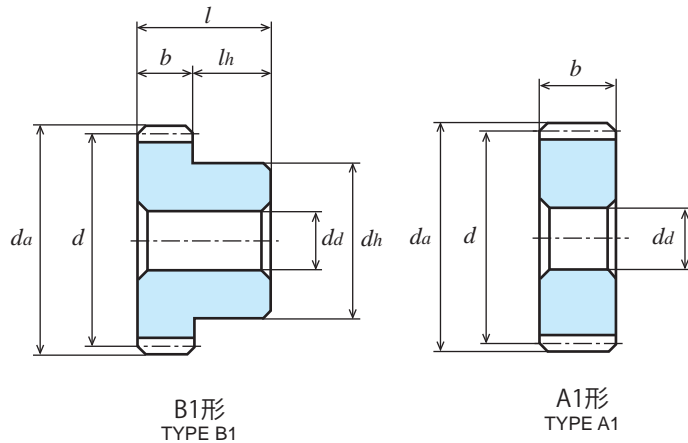

S45C 機械構造用炭素鋼 (JIS G 4051)

Material : Carbon Steel (ISO C45)

単位 : mm
Dimensions : mm

商品記号 Catalogue Number	歯数 Number of Teeth z	基準円直径 Reference Diameter d	歯先円直径 Tip Diameter da	形 Type	歯幅 Face Width b	穴径 Bore Diameter da(H7)	ハブ外径 Hub Diameter dh	ハブ長さ Hub Projection lh	全長 Overall Length l	キミぞ Key Way b ₂ × t ₂	ねじ Set Screw		重量 Weight W(g)
											M	ls	
S1S 105A - 0610F	105	φ105	φ107	A1	6	φ10	-	-	6	-	-	-	404.1
S1S 105A - 1010F	105	φ105	φ107	A1	10	φ10	-	-	10	-	-	-	673.6
S1S 105B - 0610F	105	φ105	φ107	B1	6	φ10	φ50	10	16	-	-	-	552.1
S1S 105B - 1012F	105	φ105	φ107	B1	10	φ12	φ50	10	20	-	-	-	816.1
S1S 110A - 0610F	110	φ110	φ112	A1	6	φ10	-	-	6	-	-	-	443.9
S1S 110A - 1010F	110	φ110	φ112	A1	10	φ10	-	-	10	-	-	-	739.8
S1S 110B - 0610F	110	φ110	φ112	B1	6	φ10	φ50	10	16	-	-	-	591.9
S1S 110B - 1012F	110	φ110	φ112	B1	10	φ12	φ50	10	20	-	-	-	882.4
S1S 115A - 0610F	115	φ115	φ117	A1	6	φ10	-	-	6	-	-	-	485.5
S1S 115A - 1010F	115	φ115	φ117	A1	10	φ10	-	-	10	-	-	-	809.2
S1S 115B - 0610F	115	φ115	φ117	B1	6	φ10	φ50	10	16	-	-	-	633.5
S1S 115B - 1012F	115	φ115	φ117	B1	10	φ12	φ50	10	20	-	-	-	951.7

許容伝達動力表 曲げ強さ (kW)

Allowable transfer capability table (kW) Bending Strength

歯数 z	歯幅 b	回転速度 (min ⁻¹) revolution/min								回転速度 (min ⁻¹) revolution/min
		10	100	200	400	800	1,200	1,500		
105	6	0.038	0.38	0.74	1.28	2.22	3.14	3.80	100	36.28
105	10	0.063	0.63	1.24	2.14	3.70	5.23	6.33	100	60.16
110	6	0.040	0.40	0.78	1.34	2.32	3.28	4.00	100	38.19
110	10	0.066	0.66	1.30	2.23	3.87	5.47	6.67	100	63.02
115	6	0.042	0.42	0.81	1.39	2.42	3.42	4.21	100	40.10
115	10	0.070	0.70	1.36	2.31	4.03	5.71	7.01	100	66.84

KG 規格は “並幅” (軽荷重用) と “広幅” (重荷重用) があります。ご用途に応じてお選び下さい。

KG STOCK GEARS has Wide-face width for Heavy load, and Standard-face width for Light load.

You are able to multiple choices for your suitable design from our wide range.

The above numerical values are equivalent to JGMA formulas as reference only.

動力の換算式は P26 をご参照ください。Please refer to the conversion formula of power on page P26.

平歯車 SPUR GEARS

モジュール
MODULE

1

圧力角 20° (並歯) 歯数 120

20° PRESSURE ANGLE FULL DEPTH TOOTH Z 120

JIS B 1702-1 (ISO) 8級 (高周波焼入品: 9級)
System of accuracy: JIS B 1702-1(ISO) class 8
(Induction hardened products: class 9)



New **ねじを2箇所 (120°配) にしました。**
締結力が**1.6倍**になりました。
New item with two threaded holes (120°)
Tightening power increased by 1.6 times.

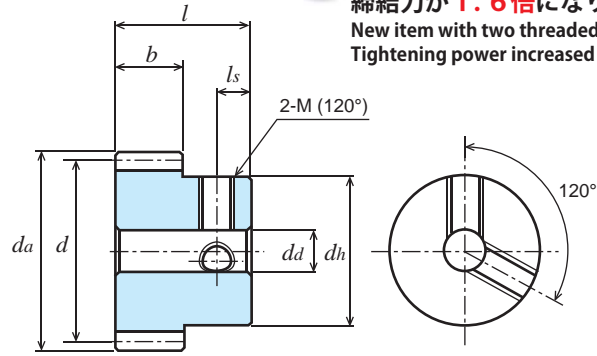

B1形
TYPE B1

S45C 機械構造用炭素鋼 (JIS G 4051)
Material: Carbon Steel (ISO C45)

単位: mm
Dimensions: mm

商品記号 Catalogue Number	歯数 Number of Teeth z	基準円直径 Reference Diameter d	歯先円直径 Tip Diameter da	形 Type	歯幅 Face Width b	穴径 Bore Diameter da(H7)	ハブ外径 Hub Diameter dh	ハブ長さ Hub Projection lh	全長 Overall Length l	キミぞ Key Way b ₂ × l ₂	ねじ Set Screw		重量 Weight W(g)
											2-M(120°)	ls	
S1S 120A - 0610F	120	φ120	φ122	A1	6	φ10	-	-	6	-	-	-	529.0
S1S 120A = 0612	120	φ120	φ122	A1	6	φ12	-	-	6	4 × 1.8	-	-	527.0
S1S 120A = 0615	120	φ120	φ122	A1	6	φ15	-	-	6	5 × 2.3	-	-	523.8
S1S 120A = 0616	120	φ120	φ122	A1	6	φ16	-	-	6	5 × 2.3	-	-	522.7
S1S 120A - 1010F	120	φ120	φ122	A1	10	φ10	-	-	10	-	-	-	881.6
S1S 120A = 1010	120	φ120	φ122	A1	10	φ10	-	-	10	3 × 1.4	-	-	881.3
S1S 120A = 1012	120	φ120	φ122	A1	10	φ12	-	-	10	4 × 1.8	-	-	878.4
S1S 120A = 1015	120	φ120	φ122	A1	10	φ15	-	-	10	5 × 2.3	-	-	873.0
S1S 120A = 1016	120	φ120	φ122	A1	10	φ16	-	-	10	5 × 2.3	-	-	871.1
S1S 120A = 1018	120	φ120	φ122	A1	10	φ18	-	-	10	6 × 2.8	-	-	866.5
S1S 120B - 0610	120	φ120	φ122	B1	6	φ10	φ30	10	16	-	-	-	578.7
S1S 120B * 0610	120	φ120	φ122	B1	6	φ10	φ30	10	16	-	2-M5	5	576.1
S1S 120B * 0612	120	φ120	φ122	B1	6	φ12	φ30	10	16	-	2-M5	5	572.0
S1S 120B * 0615	120	φ120	φ122	B1	6	φ15	φ30	10	16	-	2-M5	5	564.4
S1S 120BF - 1010	120	φ120	φ122	B1	10	φ10	φ90	10	20	-	-	-	1373.2
S1S 120B - 1010H	120	φ120	φ122	B1	10	φ10(H※)	φ90	10	20	-	-	-	1373.2
S1S 120B - 1012	120	φ120	φ122	B1	10	φ12	φ36	10	20	-	-	-	950.6
S1S 120B * 1012	120	φ120	φ122	B1	10	φ12	φ36	10	20	-	2-M5	5	947.4
S1S 120B * 1015	120	φ120	φ122	B1	10	φ15	φ36	10	20	-	2-M5	5	937.8
S1S 120B * 1016	120	φ120	φ122	B1	10	φ16	φ36	10	20	-	2-M5	5	934.1
S1S 120B * 1018	120	φ120	φ122	B1	10	φ18	φ36	10	20	-	2-M5	5	926.0

●の商品は新商品です。Products with ● marks are new item.

【=】(イコール)にはキー材が付いております。【=】: Gear with key way / with key.

【*】(アスタ)にはセットスクリーンが2個付いております。【*】: Gear with two threaded holes / with two set screws.

カタログ記号の末尾に【H】を付した商品は歯部高周波焼入済です。Gear tooth surface completed with induction hardening, Hardness HRC47 to 53.

※ 歯部高周波焼入後の穴修正は行っていません。Bore correcting after induction hardening is not completed.

追加加工の際は、追加加工時の注意をご参照ください。Please refer to Precaution for additional process when additional process.

許容伝達動力表 曲げ強さ (kW)

Allowable transfer capability table (kW) Bending Strength

歯数 z	歯幅 b	焼入 H	回転速度 (min ⁻¹) revolution/min						
			10	100	200	400	800	1,200	1,500
120	6	-	0.044	0.44	0.85	1.43	2.52	3.56	4.41
120	10	-	0.073	0.730	1.400	2.380	4.160	5.890	7.290
120	10	○	0.077	0.773	1.494	2.563	4.535	6.803	8.504

The above references are JGMA standard.

動力の換算式はP26をご参照ください。Please refer to the conversion formula of power on page P26.

許容伝達動力表 歯面強さ (kW)

Allowable transfer capability table (kW) Surface Durability

回転速度 (min ⁻¹) revolution/min						
10	100	200	400	800	1,200	1,500
-	-	-	-	-	-	-
0.014	0.140	0.280	0.480	0.910	1.360	1.740
0.062	0.685	1.365	2.415	4.405	6.726	8.490

Memo

目次
CONTENTS

インフォメーション
INFORMATION

ギヤボックス
GEAR BOXES

ノーバッキングギヤ
ANTI BACKLASH SPUR GEARS

歯研平歯
GROUND SPUR GEARS

平歯
SPUR GEARS

内歯
INTERNAL GEARS

歯ラック
GROUND RACKS

ラック
RACKS

へりかき・スクリューギヤ
HELICAL GEARS AND SCREW GEARS

ワーム・ワームホイール
WORMS AND WORM WHEELS

かみ歯
BEVEL GEARS

スプロケット
SPROCKETS

技術資料
REFERENCE DATA

平歯車 SPUR GEARS

モジュール **1.25** 圧力角 20° (並歯) 歯数 8 ~ 17
 MODULE 20° PRESSURE ANGLE FULL DEPTH TOOTH Z 8 to Z 17

JIS B 1702-1 (ISO) 8級~9級
 System of accuracy: JIS B 1702-1(ISO) class 8-9

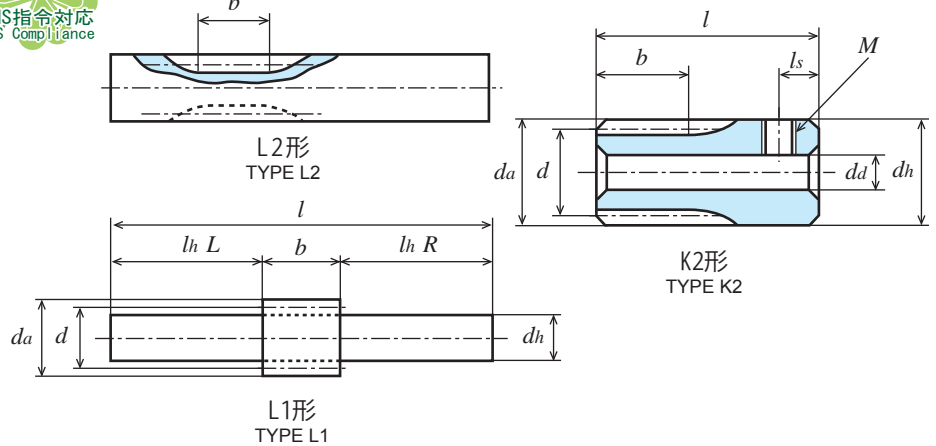

S45C 機械構造用炭素鋼 (JIS G 4051)

Material: Carbon Steel (ISO C45) * mark has been profile shifted gears. (Rack shift coefficient $x = 0.5$)

単位: mm
 Dimensions: mm

商品記号 Catalogue Number	歯数 Number of Teeth z	基準円直径 Reference Diameter d	歯先円直径 Tip Diameter d_a	形 Type	歯幅 Face Width b	穴径 Bore Diameter $d_a(H7)$	ハブ外径 Hub Diameter d_h	ハブ長さ Hub Projection l_h	全長 Overall Length l	重量 Weight $W(g)$
S1.25S 8L - 1507	8	*	$\phi 13.3$	L1	15	-	$\phi 7 (h9)$	L20 R40	75	29.8
S1.25S 8L - 1513F	8	*	$\phi 13.3$	L2	15	-	$\phi 13.3$	L20 R40	75	77.1
S1.25S 9L - 1514F	9	*	$\phi 14.56$	L2	15	-	$\phi 14.56$	L20 R40	75	92.9
S1.25S 10L - 1510	10	*	$\phi 15.83$	L1	15	-	$\phi 10 (h9)$	L20 R40	75	54.5
S1.25S 10L - 1515F	10	*	$\phi 15.83$	L2	15	-	$\phi 15.83$	L20 R40	75	110.2
S1.25S 11L - 1517F	11	*	$\phi 17.1$	L2	15	-	$\phi 17.1$	L20 R40	75	129.0
S1.25S 12K - 1508	12	$\phi 15$	$\phi 17.5$	K2	15	$\phi 8(H8)$	$\phi 17.5$	22.5	37.5	48.5
S1.25S 13K - 1508	13	$\phi 16.25$	$\phi 18.75$	K2	15	$\phi 8(H8)$	$\phi 18.75$	22.5	37.5	58.4
S1.25S 14A - 1506	14	$\phi 17.5$	$\phi 20$	A1	15	$\phi 6$	-	-	15	25.0
S1.25S 14K - 1508	14	$\phi 17.5$	$\phi 20$	K2	15	$\phi 8(H8)$	$\phi 20$	22.5	37.5	69.0
S1.25S 15A - 1506	15	$\phi 18.75$	$\phi 21.25$	A1	15	$\phi 6$	-	-	15	29.2
S1.25S 15K - 1508	15	$\phi 18.75$	$\phi 21.25$	K2	15	$\phi 8(H8)$	$\phi 21.25$	22.5	37.5	80.4
S1.25S 16A - 1506	16	$\phi 20$	$\phi 22.5$	A1	15	$\phi 6$	-	-	15	33.7
S1.25S 16K - 1508	16	$\phi 20$	$\phi 22.5$	K2	15	$\phi 8(H8)$	$\phi 22.5$	22.5	37.5	92.4
S1.25S 17A - 1506	17	$\phi 21.25$	$\phi 23.75$	A1	15	$\phi 6$	-	-	15	38.4
S1.25S 17K - 1508	17	$\phi 21.25$	$\phi 23.75$	K2	15	$\phi 8(H8)$	$\phi 23.75$	22.5	37.5	105.2

許容伝達動力表 曲げ強さ (W)

T (N · m)

Allowable transfer capability table (W) Bending Strength

歯数 z	歯幅 b	回転速度 (min ⁻¹) revolution/min							回転速度 (min ⁻¹) revolution/min
		10	100	200	400	800	1,200	1,500	
8	15	6.28	62.78	125.57	251.14	502.27	753.41	941.76	5.99
9	15	7.45	74.50	149.01	298.02	596.04	894.06	1,117.57	7.11
10	15	8.66	86.57	173.14	346.28	692.56	1,038.85	1,286.84	8.26
11	15	9.89	98.90	197.79	395.59	791.18	1,186.76	1,448.70	9.44
12	15	7.96	79.58	159.17	318.33	636.66	954.99	1,162.68	7.59
13	15	9.15	91.50	182.99	365.98	731.97	1,094.50	1,317.82	8.73
14	15	10.37	103.74	207.48	414.96	829.93	1,226.57	1,473.36	9.90
15	15	11.63	116.26	232.52	465.04	930.08	1,358.82	1,628.45	11.10
16	15	12.90	129.02	258.04	516.09	1,032.18	1,490.87	1,782.70	12.32
17	15	14.20	141.97	283.95	567.90	1,135.79	1,622.13	1,935.40	13.55

KG規格は“並幅”(軽荷重用)と“広幅”(重荷重用)があります。ご用途に応じてお選び下さい。

KG STOCK GEARS has Wide-face width for Heavy load, and Standard-face width for Light load.

You are able to multiple choices for your suitable design from our wide range.

The above numerical values are equivalent to JGMA formulas as reference only.

動力の換算式は P26 をご参照ください。Please refer to the conversion fomulas of power on page P26.

平歯車

SPUR GEARS

モジュール 1.25 圧力角 20° (並歯) 歯数 18 ~ 22
 MODULE 1.25 20° PRESSURE ANGLE FULL DEPTH TOOTH Z 18 to Z 22

JIS B 1702-1 (ISO) 8級
 System of accuracy : JIS B 1702-1(ISO) class 8



御注文には必ず“フルネームで商品記号”を明記してください。
 Please refer to the catalogue reference while ordering.

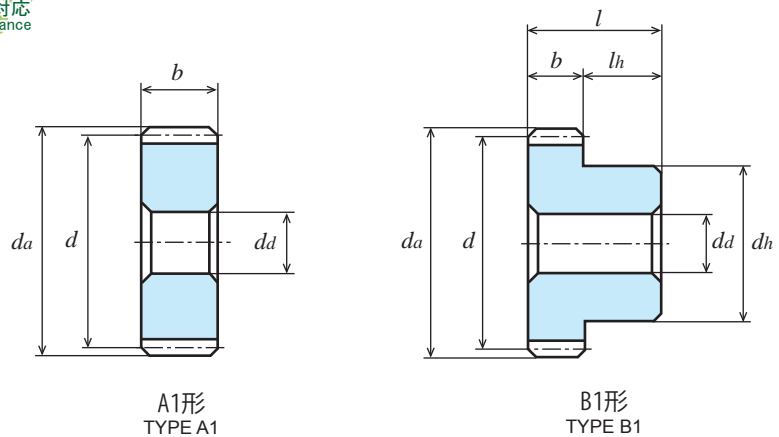

S45C 機械構造用炭素鋼 (JIS G 4051)

Material : Carbon Steel (ISO C45)

単位 : mm
 Dimensions : mm

商品記号 Catalogue Number	歯数 Number of Teeth z	基準円直径 Reference Diameter d	歯先円直径 Tip Diameter da	形 Type	歯幅 Face Width b	穴径 Bore Diameter da(H7)	ハブ外径 Hub Diameter dh	ハブ長さ Hub Projection lh	全長 Overall Length l	重量 Weight W(g)
S1.25S 18A - 1006F	18	φ22.5	φ25	A1	10	φ 6	-	-	10	29.0
S1.25S 18A - 1508F	18	φ22.5	φ25	A1	15	φ 8	-	-	15	40.9
S1.25S 18B - 1006F	18	φ22.5	φ25	B1	10	φ 6(H8)	φ16	15	25	48.5
S1.25S 18B - 1508F	18	φ22.5	φ25	B1	15	φ 8(H8)	φ16	15	30	58.7
S1.25S 19A - 1006F	19	φ23.75	φ26.25	A1	10	φ 6	-	-	10	32.6
S1.25S 19A - 1508F	19	φ23.75	φ26.25	A1	15	φ 8	-	-	15	46.3
S1.25S 19B - 1006F	19	φ23.75	φ26.25	B1	10	φ 6(H8)	φ16	15	25	52.9
S1.25S 19B - 1508F	19	φ23.75	φ26.25	B1	15	φ 8(H8)	φ16	15	30	64.0
S1.25S 20A - 1008F	20	φ25	φ27.5	A1	10	φ 8	-	-	10	34.6
S1.25S 20A - 1510F	20	φ25	φ27.5	A1	15	φ10	-	-	15	48.6
S1.25S 20B - 1008F	20	φ25	φ27.5	B1	10	φ 8(H8)	φ20	15	25	65.7
S1.25S 20B - 1510F	20	φ25	φ27.5	B1	15	φ10(H8)	φ20	15	30	76.3
S1.25S 21A - 1008F	21	φ26.25	φ28.75	A1	10	φ 8	-	-	10	38.5
S1.25S 21A - 1510F	21	φ26.25	φ28.75	A1	15	φ10	-	-	15	54.5
S1.25S 21B - 1008F	21	φ26.25	φ28.75	B1	10	φ 8(H8)	φ20	15	25	69.6
S1.25S 21B - 1510F	21	φ26.25	φ28.75	B1	15	φ10(H8)	φ20	15	30	82.2
S1.25S 22A - 1008F	22	φ27.5	φ30	A1	10	φ 8	-	-	10	42.7
S1.25S 22A - 1510F	22	φ27.5	φ30	A1	15	φ10	-	-	15	60.7
S1.25S 22B - 1008F	22	φ27.5	φ30	B1	10	φ 8(H8)	φ20	15	25	73.8
S1.25S 22B - 1510F	22	φ27.5	φ30	B1	15	φ10(H8)	φ20	15	30	88.4

許容伝達動力表 曲げ強さ (W)

T (N · m)

Allowable transfer capability table (W) Bending Strength

歯数 z	歯幅 b	回転速度 (min ⁻¹) revolution/min							回転速度 (min ⁻¹) revolution/min
		10	100	200	400	800	1,200	1,500	
18	10	10.34	103.40	206.80	413.60	827.19	1,168.29	1,390.93	9.87
18	15	15.51	155.10	310.20	620.40	1,240.79	1,752.43	2,086.40	14.81
19	10	11.24	112.40	224.79	449.59	899.18	1,256.02	1,492.27	10.73
19	15	16.86	168.60	337.19	674.38	1,348.77	1,884.04	2,238.40	16.10
20	10	12.14	121.41	242.81	485.63	964.43	1,341.98	1,591.14	11.59
20	15	18.21	182.11	364.22	728.44	1,446.64	2,012.97	2,386.72	17.39
21	10	13.05	130.49	260.97	521.95	1,028.53	1,426.86	1,688.42	12.46
21	15	19.57	195.73	391.46	782.92	1,542.80	2,140.29	2,532.63	18.69
22	10	13.97	139.69	279.38	558.77	1,092.64	1,511.30	1,784.85	13.33
22	15	20.95	209.54	419.08	838.15	1,638.95	2,266.94	2,677.28	20.01

The above numerical values are equivalent to JGMA formulas as reference only.

動力の換算式は P26 をご参照ください。Please refer to the conversion fomulas of power on page P26.

平歯車 SPUR GEARS

モジュール 1.25 圧力角 20° (並歯) 歯数 23 ~ 27
MODULE 1.25 20° PRESSURE ANGLE FULL DEPTH TOOTH Z 23 to Z 27

JIS B 1702-1 (ISO) 8級
System of accuracy : JIS B 1702-1(ISO) class 8

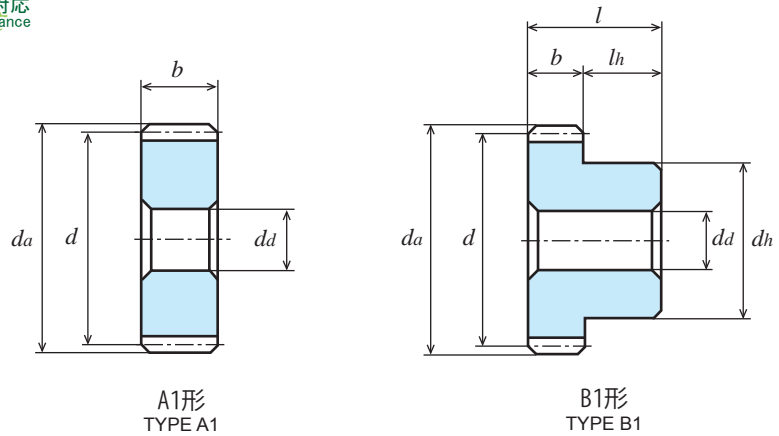

S45C 機械構造用炭素鋼 (JIS G 4051) Material : Carbon Steel (ISO C45)

単位 : mm
Dimensions : mm

商品記号 Catalogue Number	歯数 Number of Teeth <i>z</i>	基準円直径 Reference Diameter <i>d</i>	歯先円直径 Tip Diameter <i>da</i>	形 Type	歯幅 Face Width <i>b</i>	穴径 Bore Diameter <i>da(H7)</i>	ハブ外径 Hub Diameter <i>dh</i>	ハブ長さ Hub Projection <i>lh</i>	全長 Overall Length <i>l</i>	重量 Weight <i>W(g)</i>
S1.25S 23A - 1008F	23	φ28.75	φ31.25	A1	10	φ 8	-	-	10	47.0
S1.25S 23A - 1510F	23	φ28.75	φ31.25	A1	15	φ10	-	-	15	67.2
S1.25S 23B - 1008F	23	φ28.75	φ31.25	B1	10	φ 8(H8)	φ24	15	25	94.4
S1.25S 23B - 1510F	23	φ28.75	φ31.25	B1	15	φ10(H8)	φ24	15	30	111.2
S1.25S 24A - 1008F	24	φ30	φ32.5	A1	10	φ 8	-	-	10	51.5
S1.25S 24A - 1510F	24	φ30	φ32.5	A1	15	φ10	-	-	15	74.0
S1.25S 24B - 1008F	24	φ30	φ32.5	B1	10	φ 8(H8)	φ24	15	25	98.9
S1.25S 24B - 1510F	24	φ30	φ32.5	B1	15	φ10(H8)	φ24	15	30	118.0
S1.25S 25A - 1008F	25	φ31.25	φ33.75	A1	10	φ 8	-	-	10	56.3
S1.25S 25A - 1510F	25	φ31.25	φ33.75	A1	15	φ10	-	-	15	81.1
S1.25S 25B - 1008F	25	φ31.25	φ33.75	B1	10	φ 8(H8)	φ24	15	25	103.6
S1.25S 25B - 1510F	25	φ31.25	φ33.75	B1	15	φ10(H8)	φ24	15	30	125.1
S1.25S 26A - 1008F	26	φ32.5	φ35	A1	10	φ 8	-	-	10	61.2
S1.25S 26A - 1510F	26	φ32.5	φ35	A1	15	φ10	-	-	15	88.4
S1.25S 26B - 1008F	26	φ32.5	φ35	B1	10	φ 8(H8)	φ28	15	25	127.8
S1.25S 26B - 1510F	26	φ32.5	φ35	B1	15	φ10(H8)	φ28	15	30	151.7
S1.25S 27A - 1008F	27	φ33.75	φ36.25	A1	10	φ 8	-	-	10	66.3
S1.25S 27A - 1510F	27	φ33.75	φ36.25	A1	15	φ10	-	-	15	96.1
S1.25S 27B - 1008F	27	φ33.75	φ36.25	B1	10	φ 8(H8)	φ28	15	25	132.9
S1.25S 27B - 1510F	27	φ33.75	φ36.25	B1	15	φ10(H8)	φ28	15	30	159.3

許容伝達動力表 曲げ強さ (W) T (N・m)

歯数 <i>z</i>	歯幅 <i>b</i>	回転速度 (min ⁻¹) revolution/min							回転速度 (min ⁻¹) revolution/min
		10	100	200	400	800	1,200	1,500	
23	10	14.90	148.98	297.96	595.92	1,156.41	1,594.85	1,879.96	14.22
23	15	22.35	223.47	446.94	893.89	1,734.62	2,392.28	2,819.94	21.34
24	10	15.83	158.27	316.55	633.09	1,219.25	1,676.71	1,972.78	15.11
24	15	23.74	237.41	474.82	949.64	1,828.87	2,515.06	2,959.16	22.67
25	10	16.77	167.69	335.38	670.77	1,282.11	1,758.20	2,064.90	16.01
25	15	25.15	251.54	503.07	1,006.15	1,923.16	2,637.29	3,097.35	24.02
26	10	17.72	177.18	354.35	708.70	1,344.52	1,838.70	2,155.62	16.92
26	15	26.58	265.76	531.53	1,063.05	2,016.78	2,758.05	3,233.43	25.37
27	10	18.67	186.72	373.44	746.88	1,406.47	1,918.21	2,244.93	17.83
27	15	28.01	280.08	560.16	1,120.31	2,109.71	2,877.31	3,367.39	26.74

KG規格は“並幅”(軽荷重用)と“広幅”(重荷重用)があります。ご用途に応じてお選び下さい。

KG STOCK GEARS has Wide-face width for Heavy load, and Standard-face width for Light load.

You are able to multiple choices for your suitable design from our wide range.

The above numerical values are equivalent to JGMA formulas as reference only.

動力の換算式は P26 をご参照ください。Please refer to the conversion fomulas of power on page P26.

平歯車

SPUR GEARS

モジュール **1.25** 圧力角 20° (並歯) 歯数 28 ~ 34
 MODULE 20° PRESSURE ANGLE FULL DEPTH TOOTH Z 28 to Z 34

JIS B 1702-1 (ISO) 8級
 System of accuracy : JIS B 1702-1(ISO) class 8



御注文には必ず“フルネームで商品記号”を明記してください。
 Please refer to the catalogue reference while ordering.

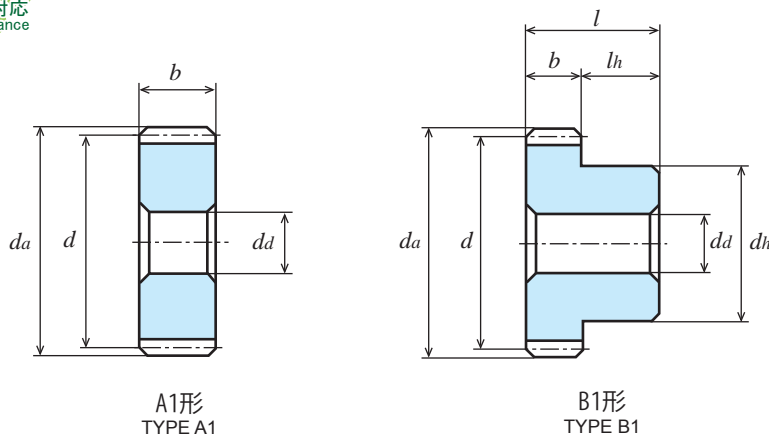

S45C 機械構造用炭素鋼 (JIS G 4051)

Material : Carbon Steel (ISO C45)

単位 : mm
 Dimensions : mm

商品記号 Catalogue Number	歯数 Number of Teeth z	基準円直径 Reference Diameter d	歯先円直径 Tip Diameter da	形 Type	歯幅 Face Width b	穴径 Bore Diameter da(H7)	ハブ外径 Hub Diameter dh	ハブ長さ Hub Projection lh	全長 Overall Length l	重量 Weight W(g)
S1.25S 28A - 1008F	28	φ35	φ37.5	A1	10	φ 8	-	-	10	71.6
S1.25S 28A - 1510F	28	φ35	φ37.5	A1	15	φ10	-	-	15	104.0
S1.25S 28B - 1008F	28	φ35	φ37.5	B1	10	φ 8(H8)	φ28	15	25	138.2
S1.25S 28B - 1510F	28	φ35	φ37.5	B1	15	φ10(H8)	φ28	15	30	167.3
S1.25S 29A - 1008F	29	φ36.25	φ38.75	A1	10	φ 8	-	-	10	77.1
S1.25S 29A - 1510F	29	φ36.25	φ38.75	A1	15	φ10	-	-	15	112.3
S1.25S 29B - 1008F	29	φ36.25	φ38.75	B1	10	φ 8(H8)	φ28	15	25	143.7
S1.25S 29B - 1510F	29	φ36.25	φ38.75	B1	15	φ10(H8)	φ28	15	30	175.5
S1.25S 30A - 1008F	30	φ37.5	φ40	A1	10	φ 8	-	-	10	82.8
S1.25S 30A - 1510F	30	φ37.5	φ40	A1	15	φ10	-	-	15	120.8
S1.25S 30B - 1008F	30	φ37.5	φ40	B1	10	φ 8(H8)	φ30	15	25	160.1
S1.25S 30B - 1510F	30	φ37.5	φ40	B1	15	φ10(H8)	φ30	15	30	194.8
S1.25S 32A - 0810F	32	φ40	φ42.5	A1	8	φ10	-	-	8	74.0
S1.25S 32A - 1312F	32	φ40	φ42.5	A1	13	φ12	-	-	13	116.7
S1.25S 32B - 0810F	32	φ40	φ42.5	B1	8	φ10	φ30	10	18	123.3
S1.25S 32B - 1312F	32	φ40	φ42.5	B1	13	φ12	φ30	12	25	172.6
S1.25S 34A - 0810F	34	φ42.5	φ45	A1	8	φ10	-	-	8	84.2
S1.25S 34A - 1312F	34	φ42.5	φ45	A1	13	φ12	-	-	13	133.2
S1.25S 34B - 0810F	34	φ42.5	φ45	B1	8	φ10	φ30	10	18	133.5
S1.25S 34B - 1312F	34	φ42.5	φ45	B1	13	φ12	φ30	12	25	189.2

許容伝達動力表 曲げ強さ (kW) T (N・m)

Allowable transfer capability table (kW) Bending Strength

歯数 z	歯幅 b	回転速度 (min ⁻¹) revolution/min							回転速度 (min ⁻¹) revolution/min
		10	100	200	400	800	1,200	1,500	
28	10	0.019	0.19	0.39	0.78	1.46	1.99	2.33	18.14
28	15	0.029	0.29	0.58	1.17	2.20	2.99	3.49	27.69
29	10	0.020	0.20	0.41	0.82	1.52	2.07	2.41	19.09
29	15	0.030	0.30	0.61	1.23	2.29	3.11	3.62	28.64
30	10	0.021	0.21	0.43	0.86	1.58	2.14	2.50	20.05
30	15	0.032	0.32	0.64	1.29	2.38	3.22	3.75	30.55
32	8	0.018	0.18	0.37	0.75	1.36	1.83	2.15	17.18
32	13	0.030	0.30	0.61	1.22	2.21	2.98	3.50	28.64
34	8	0.020	0.20	0.40	0.81	1.45	1.95	2.32	19.09
34	13	0.033	0.33	0.66	1.32	2.37	3.17	3.77	31.51

The above numerical values are equivalent to JGMA formulas as reference only.

動力の換算式は P26 をご参照ください。Please refer to the conversion fomulas of power on page P26.

目次
CONTENTS

インフォメーション
INFORMATION

ギヤボックス
GEAR BOXES

ノーバッキングギヤ
ANTI BACKLASH SPUR GEARS

歯研削歯車
GROUND SPUR GEARS

平歯車
SPUR GEARS

内歯車
INTERNAL GEARS

歯研削ラック
GROUND RACKS

ラック
RACKS

ねじり歯車
HEXICAL GEARS AND SCREW GEARS

ワーム
WORMS AND WORM WHEELS

かさ歯車
BEVEL GEARS

スプロケット
SPROCKETS

技術仕様
REFERENCE DATA

平歯車

SPUR GEARS

モジュール **1.25** 圧力角 20° (並歯) 歯数 35 ~ 42
 MODULE 20° PRESSURE ANGLE FULL DEPTH TOOTH Z 35 to Z 42

JIS B 1702-1 (ISO) 8級
 System of accuracy : JIS B 1702-1(ISO) class 8

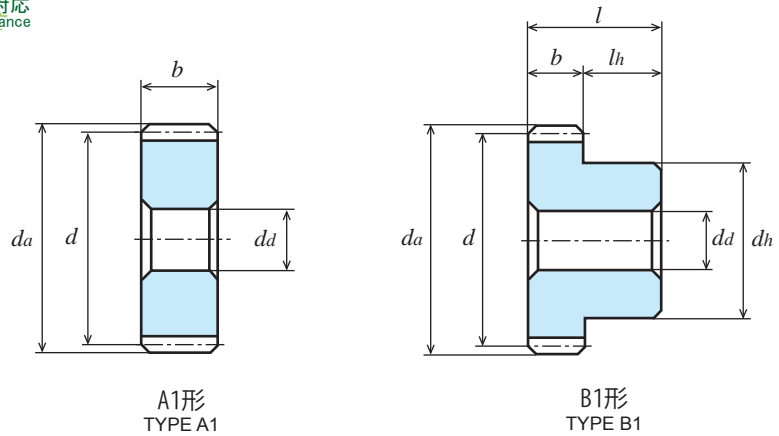

S45C 機械構造用炭素鋼 (JIS G 4051)

Material : Carbon Steel (ISO C45)

単位 : mm
 Dimensions : mm

商品記号 Catalogue Number	歯数 Number of Teeth <i>z</i>	基準円直径 Reference Diameter <i>d</i>	歯先円直径 Tip Diameter <i>da</i>	形 Type	歯幅 Face Width <i>b</i>	穴径 Bore Diameter <i>da</i> (H7)	ハブ外径 Hub Diameter <i>dh</i>	ハブ長さ Hub Projection <i>lh</i>	全長 Overall Length <i>l</i>	重量 Weight <i>W</i> (g)
S1.25S 35A - 0810F	35	φ43.75	φ46.25	A1	8	φ10	-	-	8	89.5
S1.25S 35A - 1312F	35	φ43.75	φ46.25	A1	13	φ12	-	-	13	141.9
S1.25S 35B - 0810F	35	φ43.75	φ46.25	B1	8	φ10	φ36	10	18	163.2
S1.25S 35B - 1312F	35	φ43.75	φ46.25	B1	13	φ12	φ36	12	25	227.1
S1.25S 36A - 0810F	36	φ45	φ47.5	A1	8	φ10	-	-	8	95.0
S1.25S 36A - 1312F	36	φ45	φ47.5	A1	13	φ12	-	-	13	150.8
S1.25S 36B - 0810F	36	φ45	φ47.5	B1	8	φ10	φ36	10	18	168.7
S1.25S 36B - 1312F	36	φ45	φ47.5	B1	13	φ12	φ36	12	25	236.0
S1.25S 38A - 0810F	38	φ47.5	φ50	A1	8	φ10	-	-	8	106.4
S1.25S 38A - 1312F	38	φ47.5	φ50	A1	13	φ12	-	-	13	169.3
S1.25S 38B - 0810F	38	φ47.5	φ50	B1	8	φ10	φ36	10	18	180.1
S1.25S 38B - 1312F	38	φ47.5	φ50	B1	13	φ12	φ36	12	25	254.5
S1.25S 40A - 0810F	40	φ50	φ52.5	A1	8	φ10	-	-	8	118.4
S1.25S 40A - 1312F	40	φ50	φ52.5	A1	13	φ12	-	-	13	188.8
S1.25S 40B - 0810F	40	φ50	φ52.5	B1	8	φ10	φ40	10	18	210.9
S1.25S 40B - 1312F	40	φ50	φ52.5	B1	13	φ12	φ40	12	25	296.6
S1.25S 42A - 0810F	42	φ52.5	φ55	A1	8	φ10	-	-	8	131.0
S1.25S 42A - 1312F	42	φ52.5	φ55	A1	13	φ12	-	-	13	209.4
S1.25S 42B - 0810F	42	φ52.5	φ55	B1	8	φ10	φ40	10	18	223.5
S1.25S 42B - 1312F	42	φ52.5	φ55	B1	13	φ12	φ40	12	25	317.1

許容伝達動力表 曲げ強さ (kW)

T (N・m)

Allowable transfer capability table (kW) Bending Strength

歯数 <i>z</i>	歯幅 <i>b</i>	回転速度 (min ⁻¹) revolution/min							回転速度 (min ⁻¹) revolution/min
		10	100	200	400	800	1,200	1,500	100
35	8	0.021	0.21	0.42	0.84	1.50	2.01	2.40	20.05
35	13	0.034	0.34	0.68	1.37	2.44	3.27	3.90	32.46
36	8	0.021	0.21	0.43	0.87	1.55	2.06	2.48	20.05
36	13	0.035	0.35	0.71	1.42	2.52	3.36	4.03	33.42
38	8	0.023	0.23	0.47	0.94	1.64	2.17	2.64	21.96
38	13	0.038	0.38	0.76	1.53	2.66	3.53	4.29	36.28
40	8	0.025	0.25	0.50	0.99	1.72	2.31	2.80	23.87
40	13	0.040	0.40	0.81	1.62	2.80	3.75	4.55	38.19
42	8	0.026	0.26	0.53	1.05	1.81	2.44	2.96	34.82
42	13	0.043	0.43	0.87	1.71	2.94	3.97	4.81	41.06

KG規格は“並幅”(軽荷重用)と“広幅”(重荷重用)があります。ご用途に応じてお選び下さい。

KG STOCK GEARS has Wide-face width for Heavy load, and Standard-face width for Light load.

You are able to multiple choices for your suitable design from our wide range.

The above numerical values are equivalent to JGMA formulas as reference only.

動力の換算式はP26をご参照ください。Please refer to the conversion fomulas of power on page P26.

平歯車 SPUR GEARS

モジュール **1.25** 圧力角 20° (並歯) 歯数 44 ~ 50
 MODULE 20° PRESSURE ANGLE FULL DEPTH TOOTH Z 44 to Z 50

JIS B 1702-1 (ISO) 8級
 System of accuracy : JIS B 1702-1(ISO) class 8



御注文には必ず “フルネームで商品記号” を明記してください。
 Please refer to the catalogue reference while ordering.

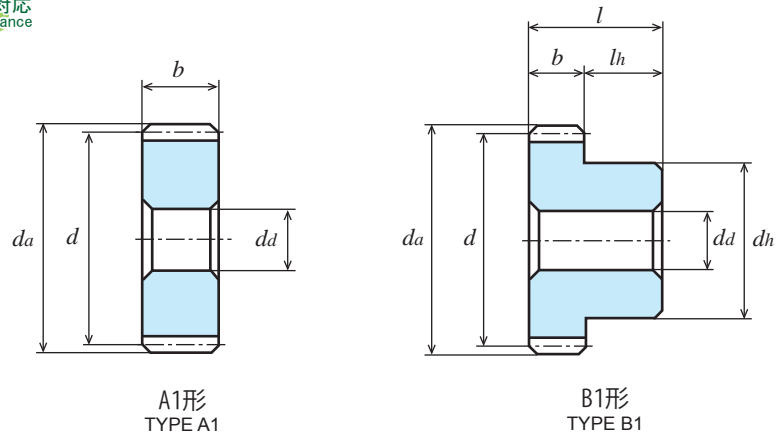

S45C 機械構造用炭素鋼 (JIS G 4051) Material : Carbon Steel (ISO C45)

単位 : mm
 Dimensions : mm

商品記号 Catalogue Number	歯数 Number of Teeth z	基準円直径 Reference Diameter d	歯先円直径 Tip Diameter da	形 Type	歯幅 Face Width b	穴径 Bore Diameter da(H7)	ハブ外径 Hub Diameter dh	ハブ長さ Hub Projection lh	全長 Overall Length l	重量 Weight W(g)
S1.25S 44A - 0810F	44	φ55	φ57.5	A1	8	φ10	-	-	8	144.3
S1.25S 44A - 1312F	44	φ55	φ57.5	A1	13	φ12	-	-	13	230.9
S1.25S 44B - 0810F	44	φ55	φ57.5	B1	8	φ10	φ40	10	18	236.8
S1.25S 44B - 1312F	44	φ55	φ57.5	B1	13	φ12	φ40	12	25	338.6
S1.25S 45A - 0810F	45	φ56.25	φ58.75	A1	8	φ10	-	-	8	151.1
S1.25S 45A - 1312F	45	φ56.25	φ58.75	A1	13	φ12	-	-	13	242.1
S1.25S 45B - 0810F	45	φ56.25	φ58.75	B1	8	φ10	φ40	10	18	243.6
S1.25S 45B - 1312F	45	φ56.25	φ58.75	B1	13	φ12	φ40	12	25	349.8
S1.25S 46A - 0810F	46	φ57.5	φ60	A1	8	φ10	-	-	8	158.1
S1.25S 46A - 1312F	46	φ57.5	φ60	A1	13	φ12	-	-	13	253.5
S1.25S 46B - 0810F	46	φ57.5	φ60	B1	8	φ10	φ40	10	18	250.6
S1.25S 46B - 1312F	46	φ57.5	φ60	B1	13	φ12	φ40	12	25	361.2
S1.25S 48A - 0810F	48	φ60	φ62.5	A1	8	φ10	-	-	8	172.6
S1.25S 48A - 1312F	48	φ60	φ62.5	A1	13	φ12	-	-	13	277.0
S1.25S 48B - 0810F	48	φ60	φ62.5	B1	8	φ10	φ40	10	18	265.1
S1.25S 48B - 1312F	48	φ60	φ62.5	B1	13	φ12	φ40	12	25	384.7
S1.25S 50A - 0812F	50	φ62.5	φ65	A1	8	φ12	-	-	8	185.6
S1.25S 50A - 1314F	50	φ62.5	φ65	A1	13	φ14	-	-	13	297.4
S1.25S 50B - 0812F	50	φ62.5	φ65	B1	8	φ12	φ45	10	18	301.5
S1.25S 50B - 1314F	50	φ62.5	φ65	B1	13	φ14	φ45	12	25	432.7

許容伝達動力表 曲げ強さ (kW) T (N・m)

Allowable transfer capability table (kW) Bending Strength

歯数 z	歯幅 b	回転速度 (min ⁻¹) revolution/min							回転速度 (min ⁻¹) revolution/min
		10	100	200	400	800	1,200	1,500	
44	8	0.028	0.28	0.56	1.10	1.89	2.57	3.11	100
44	13	0.046	0.46	0.92	1.80	3.08	4.18	5.06	100
45	8	0.029	0.29	0.58	1.13	1.94	2.63	3.19	100
45	13	0.047	0.47	0.94	1.84	3.15	4.28	5.18	100
46	8	0.030	0.29	0.59	1.16	1.98	2.70	3.27	100
46	13	0.048	0.48	0.97	1.89	3.21	4.39	5.31	100
48	8	0.031	0.31	0.63	1.21	2.06	2.83	3.42	100
48	13	0.051	0.51	1.02	1.97	3.35	4.60	5.56	100
50	8	0.033	0.33	0.66	1.27	2.14	2.96	3.57	100
50	13	0.054	0.54	1.08	2.06	3.47	4.81	5.80	100

The above numerical values are equivalent to JGMA formulas as reference only.

動力の換算式は P26 をご参照ください。Please refer to the conversion fomulas of power on page P26.

平歯車 SPUR GEARS

モジュール 1.25 圧力角 20° (並歯) 歯数 52 ~ 58
MODULE 1.25 20° PRESSURE ANGLE FULL DEPTH TOOTH Z 52 to Z 58

JIS B 1702-1 (ISO) 8 級
System of accuracy : JIS B 1702-1(ISO) class 8

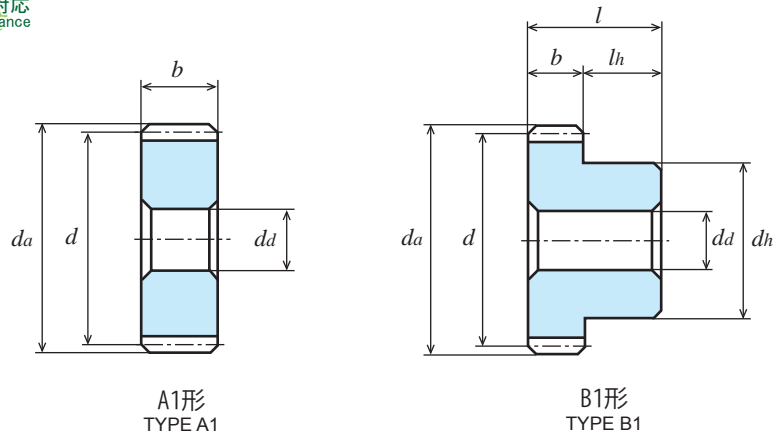

S45C 機械構造用炭素鋼 (JIS G 4051) Material : Carbon Steel (ISO C45)

単位 : mm
Dimensions : mm

商品記号 Catalogue Number	歯数 Number of Teeth z	基準円直径 Reference Diameter d	歯先円直径 Tip Diameter d_a	形 Type	歯幅 Face Width b	穴径 Bore Diameter $d_a(H7)$	ハブ外径 Hub Diameter d_h	ハブ長さ Hub Projection l_h	全長 Overall Length l	重量 Weight $W(g)$
S1.25S 52A - 0812F	52	φ65	φ67.5	A1	8	φ12	-	-	8	201.3
S1.25S 52A - 1314F	52	φ65	φ67.5	A1	13	φ14	-	-	13	322.9
S1.25S 52B - 0812F	52	φ65	φ67.5	B1	8	φ12	φ45	10	18	317.3
S1.25S 52B - 1314F	52	φ65	φ67.5	B1	13	φ14	φ45	12	25	458.2
S1.25S 54A - 0812F	54	φ67.5	φ70	A1	8	φ12	-	-	8	217.6
S1.25S 54A - 1314F	54	φ67.5	φ70	A1	13	φ14	-	-	13	349.5
S1.25S 54B - 0812F	54	φ67.5	φ70	B1	8	φ12	φ45	10	18	333.6
S1.25S 54B - 1314F	54	φ67.5	φ70	B1	13	φ14	φ45	12	25	484.8
S1.25S 55A - 0812F	55	φ68.75	φ71.25	A1	8	φ12	-	-	8	226.0
S1.25S 55A - 1314F	55	φ68.75	φ71.25	A1	13	φ14	-	-	13	363.1
S1.25S 55B - 0812F	55	φ68.75	φ71.25	B1	8	φ12	φ45	10	18	342.1
S1.25S 55B - 1314F	55	φ68.75	φ71.25	B1	13	φ14	φ45	12	25	498.4
S1.25S 56A - 0812F	56	φ70	φ72.5	A1	8	φ12	-	-	8	234.6
S1.25S 56A - 1314F	56	φ70	φ72.5	A1	13	φ14	-	-	13	377.0
S1.25S 56B - 0812F	56	φ70	φ72.5	B1	8	φ12	φ45	10	18	350.6
S1.25S 56B - 1314F	56	φ70	φ72.5	B1	13	φ14	φ45	12	25	512.3
S1.25S 58A - 0812F	58	φ72.5	φ75	A1	8	φ12	-	-	8	252.2
S1.25S 58A - 1314F	58	φ72.5	φ75	A1	13	φ14	-	-	13	405.6
S1.25S 58B - 0812F	58	φ72.5	φ75	B1	8	φ12	φ45	10	18	368.1
S1.25S 58B - 1314F	58	φ72.5	φ75	B1	13	φ14	φ45	12	25	540.9

許容伝達動力表 曲げ強さ (kW)

T (N · m)

Allowable transfer capability table (kW) Bending Strength

歯数 z	歯幅 b	回転速度 (min ⁻¹) revolution/min							回転速度 (min ⁻¹) revolution/min
		10	100	200	400	800	1,200	1,500	
52	8	0.034	0.34	0.69	1.32	2.21	3.09	3.72	32.46
52	13	0.056	0.56	1.13	2.15	3.60	5.02	6.06	53.47
54	8	0.036	0.36	0.73	1.37	2.29	3.21	3.88	34.37
54	13	0.059	0.59	1.18	2.23	3.72	5.23	6.31	56.34
55	8	0.037	0.37	0.74	1.40	2.33	3.28	3.96	35.33
55	13	0.060	0.60	1.21	2.27	3.78	5.33	6.44	57.29
56	8	0.038	0.38	0.76	1.42	2.36	3.34	4.04	36.28
56	13	0.062	0.62	1.24	2.32	3.84	5.43	6.57	59.20
58	8	0.039	0.39	0.79	1.47	2.44	3.47	4.19	37.24
58	13	0.064	0.64	1.29	2.40	3.97	5.63	6.82	61.11

KG 規格は“並幅” (軽荷重用) と“広幅” (重荷重用) があります。ご用途に応じてお選び下さい。

KG STOCK GEARS has Wide-face width for Heavy load, and Standard-face width for Light load.

You are able to multiple choices for your suitable design from our wide range.

The above numerical values are equivalent to JGMA formulas as reference only.

動力の換算式は P26 をご参照ください。Please refer to the conversion fomulas of power on page P26.

JIS B 1702-1 (ISO) 8 級
 System of accuracy : JIS B 1702-1(ISO) class 8



御注文には必ず “フルネームで商品記号” を明記してください。
 Please refer to the catalogue reference while ordering.

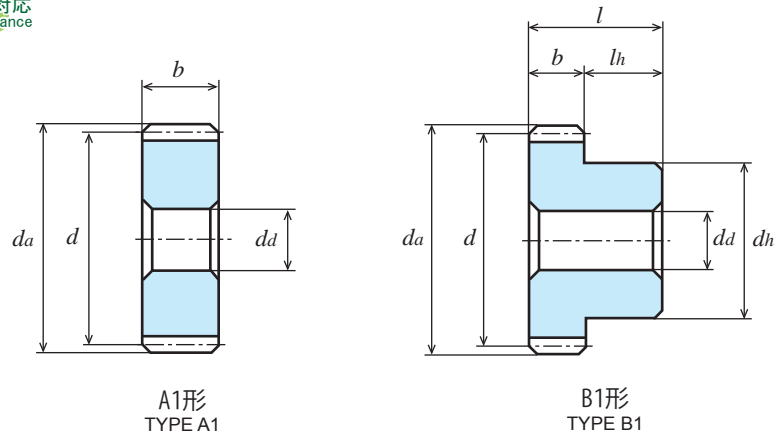

S45C 機械構造用炭素鋼 (JIS G 4051)

Material : Carbon Steel (ISO C45)

単位 : mm
 Dimensions : mm

商品記号 Catalogue Number	歯数 Number of Teeth z	基準円直径 Reference Diameter d	歯先円直径 Tip Diameter da	形 Type	歯幅 Face Width b	穴径 Bore Diameter da(H7)	ハブ外径 Hub Diameter dh	ハブ長さ Hub Projection lh	全長 Overall Length l	重量 Weight W(g)
S1.25S 60A - 0812F	60	φ75	φ77.5	A1	8	φ12	-	-	8	270.3
S1.25S 60A - 1314F	60	φ75	φ77.5	A1	13	φ14	-	-	13	435.1
S1.25S 60B - 0812F	60	φ75	φ77.5	B1	8	φ12	φ50	10	18	415.6
S1.25S 60B - 1314F	60	φ75	φ77.5	B1	13	φ14	φ50	12	25	605.6
S1.25S 62A - 0812F	62	φ77.5	φ80	A1	8	φ12	-	-	8	289.1
S1.25S 62A - 1314F	62	φ77.5	φ80	A1	13	φ14	-	-	13	465.7
S1.25S 62B - 0812F	62	φ77.5	φ80	B1	8	φ12	φ50	10	18	434.4
S1.25S 62B - 1314F	62	φ77.5	φ80	B1	13	φ14	φ50	12	25	636.2
S1.25S 64A - 0812F	64	φ80	φ82.5	A1	8	φ12	-	-	8	308.6
S1.25S 64A - 1314F	64	φ80	φ82.5	A1	13	φ14	-	-	13	497.2
S1.25S 64B - 0812F	64	φ80	φ82.5	B1	8	φ12	φ50	10	18	453.8
S1.25S 64B - 1314F	64	φ80	φ82.5	B1	13	φ14	φ50	12	25	667.7
S1.25S 65A - 0812F	65	φ81.25	φ83.75	A1	8	φ12	-	-	8	318.5
S1.25S 65A - 1314F	65	φ81.25	φ83.75	A1	13	φ14	-	-	13	513.4
S1.25S 65B - 0812F	65	φ81.25	φ83.75	B1	8	φ12	φ50	10	18	463.8
S1.25S 65B - 1314F	65	φ81.25	φ83.75	B1	13	φ14	φ50	12	25	683.9
S1.25S 66A - 0812F	66	φ82.5	φ85	A1	8	φ12	-	-	8	328.6
S1.25S 66A - 1314F	66	φ82.5	φ85	A1	13	φ14	-	-	13	529.8
S1.25S 66B - 0812F	66	φ82.5	φ85	B1	8	φ12	φ50	10	18	473.9
S1.25S 66B - 1314F	66	φ82.5	φ85	B1	13	φ14	φ50	12	25	700.3

許容伝達動力表 曲げ強さ (kW) T (N・m)

Allowable transfer capability table (kW) Bending Strength

歯数 z	歯幅 b	回転速度 (min ⁻¹) revolution/min							回転速度 (min ⁻¹) revolution/min
		10	100	200	400	800	1,200	1,500	
60	8	0.041	0.41	0.82	1.52	2.53	3.59	4.35	39.15
60	13	0.067	0.67	1.34	2.48	4.12	5.84	7.07	63.98
62	8	0.043	0.43	0.86	1.57	2.63	3.71	4.50	41.06
62	13	0.070	0.70	1.40	2.56	4.27	6.03	7.32	66.84
64	8	0.044	0.44	0.89	1.62	2.72	3.83	4.65	42.01
64	13	0.072	0.72	1.45	2.64	4.42	6.23	7.57	68.75
65	8	0.045	0.45	0.91	1.65	2.76	3.90	4.73	42.97
65	13	0.074	0.74	1.48	2.68	4.49	6.34	7.69	70.66
66	8	0.046	0.46	0.92	1.67	2.81	3.96	4.81	43.92
66	13	0.075	0.75	1.51	2.72	4.56	6.44	7.81	71.62

The above numerical values are equivalent to JGMA formulas as reference only.

動力の換算式は P26 をご参照ください。Please refer to the conversion fomulas of power on page P26.

平歯車 SPUR GEARS

モジュール **1.25** 圧力角 20° (並歯) 歯数 68 ~ 80
 MODULE 20° PRESSURE ANGLE FULL DEPTH TOOTH Z 68 to Z 80

JIS B 1702-1 (ISO) 8級
 System of accuracy : JIS B 1702-1(ISO) class 8

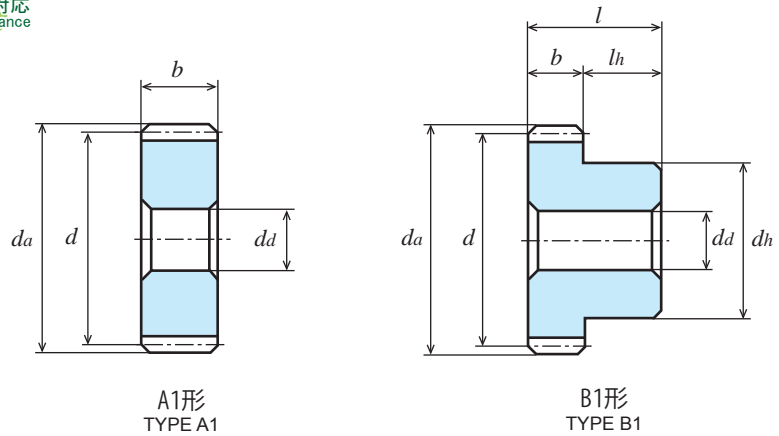

S45C 機械構造用炭素鋼 (JIS G 4051) Material : Carbon Steel (ISO C45)

単位 : mm
 Dimensions : mm

商品記号 Catalogue Number	歯数 Number of Teeth z	基準円直径 Reference Diameter d	歯先円直径 Tip Diameter da	形 Type	歯幅 Face Width b	穴径 Bore Diameter da(H7)	ハブ外径 Hub Diameter dh	ハブ長さ Hub Projection lh	全長 Overall Length l	重量 Weight W(g)
S1.25S 68A - 0812F	68	φ 85	φ 87.5	A1	8	φ12	-	-	8	349.3
S1.25S 68A - 1314F	68	φ 85	φ 87.5	A1	13	φ14	-	-	13	563.4
S1.25S 68B - 0812F	68	φ 85	φ 87.5	B1	8	φ12	φ50	10	18	494.5
S1.25S 68B - 1314F	68	φ 85	φ 87.5	B1	13	φ14	φ50	12	25	733.8
S1.25S 70A - 0814F	70	φ 87.5	φ 90	A1	8	φ14	-	-	8	368.0
S1.25S 70A - 1316F	70	φ 87.5	φ 90	A1	13	φ16	-	-	13	593.1
S1.25S 70B - 0814F	70	φ 87.5	φ 90	B1	8	φ14	φ55	10	18	542.4
S1.25S 70B - 1316F	70	φ 87.5	φ 90	B1	13	φ16	φ55	12	25	798.0
S1.25S 72A - 0814F	72	φ 90	φ 92.5	A1	8	φ14	-	-	8	389.8
S1.25S 72A - 1316F	72	φ 90	φ 92.5	A1	13	φ16	-	-	13	628.7
S1.25S 72B - 0814F	72	φ 90	φ 92.5	B1	8	φ14	φ55	10	18	564.3
S1.25S 72B - 1316F	72	φ 90	φ 92.5	B1	13	φ16	φ55	12	25	833.6
S1.25S 75A - 0814F	75	φ 93.75	φ 96.25	A1	8	φ14	-	-	8	423.8
S1.25S 75A - 1316F	75	φ 93.75	φ 96.25	A1	13	φ16	-	-	13	683.9
S1.25S 75B - 0814F	75	φ 93.75	φ 96.25	B1	8	φ14	φ55	10	18	598.3
S1.25S 75B - 1316F	75	φ 93.75	φ 96.25	B1	13	φ16	φ55	12	25	888.8
S1.25S 80A - 0814F	80	φ100	φ102.5	A1	8	φ14	-	-	8	483.6
S1.25S 80A - 1316F	80	φ100	φ102.5	A1	13	φ16	-	-	13	781.0
S1.25S 80B - 0814F	80	φ100	φ102.5	B1	8	φ14	φ60	10	18	693.4
S1.25S 80B - 1316F	80	φ100	φ102.5	B1	13	φ16	φ60	12	25	1,028.0

許容伝達動力表 曲げ強さ (kW) T (N・m)

歯数 z	歯幅 b	回転速度 (min ⁻¹) revolution/min							回転速度 (min ⁻¹) revolution/min
		10	100	200	400	800	1,200	1,500	
68	8	0.048	0.48	0.96	1.72	2.90	4.09	4.96	45.83
68	13	0.078	0.78	1.56	2.80	4.71	6.65	8.06	74.48
70	8	0.049	0.49	0.99	1.77	2.98	4.22	5.11	46.79
70	13	0.080	0.80	1.61	2.87	4.85	6.85	8.30	76.39
72	8	0.051	0.51	1.02	1.81	3.07	4.34	5.25	48.70
72	13	0.083	0.84	1.67	2.96	5.00	7.06	8.55	80.21
75	8	0.054	0.54	1.08	1.88	3.20	4.53	5.47	51.56
75	13	0.087	0.88	1.76	3.07	5.22	7.37	8.90	84.03
80	8	0.058	0.58	1.15	2.00	3.42	4.84	5.84	55.38
80	13	0.094	0.95	1.88	3.25	5.57	7.87	9.49	90.72

KG規格は“並幅”(軽荷重用)と“広幅”(重荷重用)があります。ご用途に応じてお選び下さい。

KG STOCK GEARS has Wide-face width for Heavy load, and Standard-face width for Light load.

You are able to multiple choices for your suitable design from our wide range.

The above numerical values are equivalent to JGMA formulas as reference only.

動力の換算式は P26 をご参照ください。Please refer to the conversion fomulas of power on page P26.

平歯車

SPUR GEARS

モジュール **1.25** 圧力角 20° (並歯) 歯数 84 ~ 96
 MODULE 20° PRESSURE ANGLE FULL DEPTH TOOTH Z 84 to Z 96

JIS B 1702-1 (ISO) 8 級
 System of accuracy : JIS B 1702-1(ISO) class 8



御注文には必ず “フルネームで商品記号” を明記してください。
 Please refer to the catalogue reference while ordering.

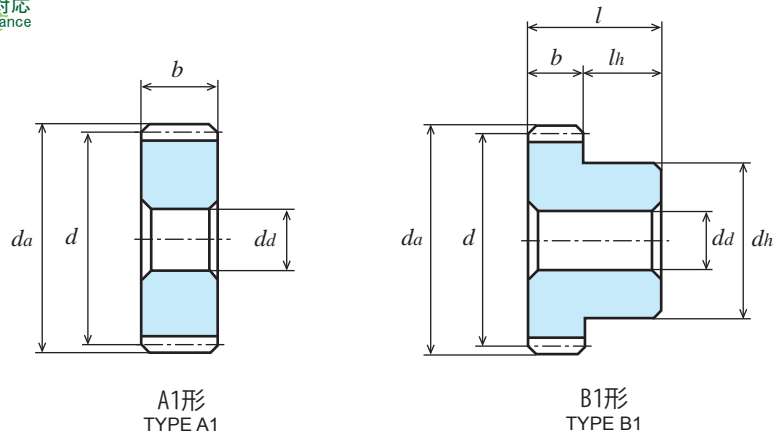

S45C 機械構造用炭素鋼 (JIS G 4051)

Material : Carbon Steel (ISO C45)

単位 : mm
 Dimensions : mm

商品記号 Catalogue Number	歯数 Number of Teeth z	基準円直径 Reference Diameter d	歯先円直径 Tip Diameter da	形 Type	歯幅 Face Width b	穴径 Bore Diameter da(H7)	ハブ外径 Hub Diameter dh	ハブ長さ Hub Projection lh	全長 Overall Length l	重量 Weight W(kg)
S1.25S 84A - 0814F	84	φ105	φ107.5	A1	8	φ14	-	-	8	0.53
S1.25S 84A - 1316F	84	φ105	φ107.5	A1	13	φ16	-	-	13	0.86
S1.25S 84B - 0814F	84	φ105	φ107.5	B1	8	φ14	φ60	10	18	0.74
S1.25S 84B - 1316F	84	φ105	φ107.5	B1	13	φ16	φ60	12	25	1.11
S1.25S 85A - 0814F	85	φ106.25	φ108.75	A1	8	φ14	-	-	8	0.55
S1.25S 85A - 1316F	85	φ106.25	φ108.75	A1	13	φ16	-	-	13	0.88
S1.25S 85B - 0814F	85	φ106.25	φ108.75	B1	8	φ14	φ60	10	18	0.76
S1.25S 85B - 1316F	85	φ106.25	φ108.75	B1	13	φ16	φ60	12	25	1.13
S1.25S 90A - 0816F	90	φ112.5	φ115	A1	8	φ16	-	-	8	0.61
S1.25S 90A - 1318F	90	φ112.5	φ115	A1	13	φ18	-	-	13	0.99
S1.25S 90B - 0816F	90	φ112.5	φ115	B1	8	φ16	φ65	10	18	0.86
S1.25S 90B - 1318F	90	φ112.5	φ115	B1	13	φ18	φ65	12	25	1.28
S1.25S 95A - 0816F	95	φ118.75	φ121.25	A1	8	φ16	-	-	8	0.68
S1.25S 95A - 1318F	95	φ118.75	φ121.25	A1	13	φ18	-	-	13	1.10
S1.25S 95B - 0816F	95	φ118.75	φ121.25	B1	8	φ16	φ65	10	18	0.93
S1.25S 95B - 1318F	95	φ118.75	φ121.25	B1	13	φ18	φ65	12	25	1.39
S1.25S 96A - 0816F	96	φ120	φ122.5	A1	8	φ16	-	-	8	0.70
S1.25S 96A - 1318F	96	φ120	φ122.5	A1	13	φ18	-	-	13	1.13
S1.25S 96B - 0816F	96	φ120	φ122.5	B1	8	φ16	φ65	10	18	0.94
S1.25S 96B - 1318F	96	φ120	φ122.5	B1	13	φ18	φ65	12	25	1.42

許容伝達動力表 曲げ強さ (kW)

T (N・m)

Allowable transfer capability table (kW) Bending Strength

歯数 z	歯幅 b	回転速度 (min ⁻¹) revolution/min							回転速度 (min ⁻¹) revolution/min
		10	100	200	400	800	1,200	1,500	
84	8	0.061	0.61	1.21	2.08	3.59	5.07	6.15	58.25
84	13	0.099	1.00	1.97	3.39	5.84	8.25	10.00	95.49
85	8	0.062	0.62	1.22	2.10	3.63	5.13	6.23	59.20
85	13	0.101	1.01	1.99	3.42	5.91	8.35	10.13	96.45
90	8	0.066	0.66	1.29	2.21	3.84	5.43	6.65	63.02
90	13	0.108	1.08	2.11	3.60	6.25	8.84	10.82	103.13
95	8	0.070	0.70	1.36	2.31	4.04	5.73	7.07	66.84
95	13	0.115	1.15	2.22	3.76	6.58	9.31	11.50	109.82
96	8	0.071	0.71	1.37	2.33	4.09	5.78	7.16	67.80
96	13	0.116	1.16	2.24	3.79	6.65	9.41	11.64	110.77

The above numerical values are equivalent to JGMA formulas as reference only.

動力の換算式は P26 をご参照ください。Please refer to the conversion fomulas of power on page P26.

平歯車 SPUR GEARS

モジュール 1.25 圧力角 20° (並歯) 歯数 100 ~ 120
MODULE 1.25 20° PRESSURE ANGLE FULL DEPTH TOOTH Z 100 to Z 120

JIS B 1702-1 (ISO) 8級
System of accuracy : JIS B 1702-1(ISO) class 8

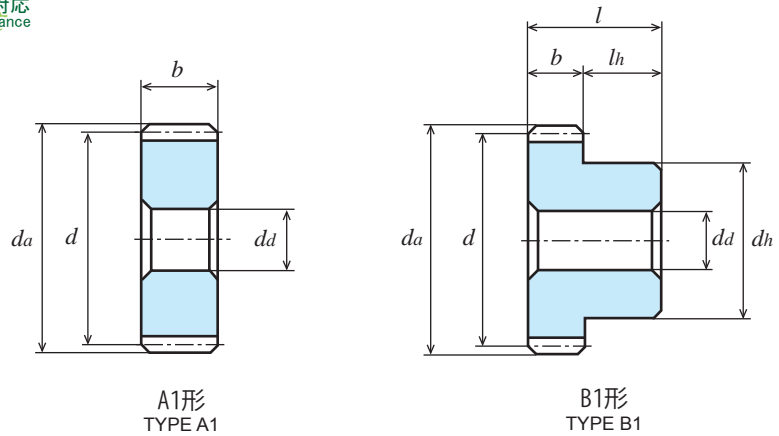

S45C 機械構造用炭素鋼 (JIS G 4051) Material : Carbon Steel (ISO C45)

単位 : mm
Dimensions : mm

商品記号 Catalogue Number	歯数 Number of Teeth <i>z</i>	基準円直径 Reference Diameter <i>d</i>	歯先円直径 Tip Diameter <i>da</i>	形 Type	歯幅 Face Width <i>b</i>	穴径 Bore Diameter <i>da</i> (H7)	ハブ外径 Hub Diameter <i>dh</i>	ハブ長さ Hub Projection <i>lh</i>	全長 Overall Length <i>l</i>	重量 Weight <i>W</i> (kg)
S1.25S 100A - 0816F	100	φ125	φ127.5	A1	8	φ16	-	-	8	0.76
S1.25S 100A - 1318F	100	φ125	φ127.5	A1	13	φ18	-	-	13	1.23
S1.25S 100B - 0816F	100	φ125	φ127.5	B1	8	φ16	φ65	10	18	1.00
S1.25S 100B - 1318F	100	φ125	φ127.5	B1	13	φ18	φ65	12	25	1.52
S1.25S 105A - 0816F	105	φ131.25	φ133.75	A1	8	φ16	-	-	8	0.84
S1.25S 105A - 1318F	105	φ131.25	φ133.75	A1	13	φ18	-	-	13	1.35
S1.25S 105B - 0816F	105	φ131.25	φ133.75	B1	8	φ16	φ70	10	18	1.12
S1.25S 105B - 1318F	105	φ131.25	φ133.75	B1	13	φ18	φ70	12	25	1.69
S1.25S 110A - 0818F	110	φ137.5	φ140	A1	8	φ18	-	-	8	0.92
S1.25S 110A - 1320F	110	φ137.5	φ140	A1	13	φ20	-	-	13	1.48
S1.25S 110B - 0818F	110	φ137.5	φ140	B1	8	φ18	φ75	10	18	1.24
S1.25S 110B - 1320F	110	φ137.5	φ140	B1	13	φ20	φ75	12	25	1.87
S1.25S 115A - 0818F	115	φ143.75	φ146.25	A1	8	φ18	-	-	8	1.00
S1.25S 115A - 1320F	115	φ143.75	φ146.25	A1	13	φ20	-	-	13	1.62
S1.25S 115B - 0818F	115	φ143.75	φ146.25	B1	8	φ18	φ75	10	18	1.33
S1.25S 115B - 1320F	115	φ143.75	φ146.25	B1	13	φ20	φ75	12	25	2.01
S1.25S 120A - 0818F	120	φ150	φ152.5	A1	8	φ18	-	-	8	1.09
S1.25S 120A - 1320F	120	φ150	φ152.5	A1	13	φ20	-	-	13	1.77
S1.25S 120B - 0818F	120	φ150	φ152.5	B1	8	φ18	φ80	10	18	1.47
S1.25S 120B - 1320F	120	φ150	φ152.5	B1	13	φ20	φ80	12	25	2.22

許容伝達動力表 曲げ強さ (kW)

T (N・m)

Allowable transfer capability table (kW) Bending Strength

歯数 <i>z</i>	歯幅 <i>b</i>	回転速度 (min ⁻¹) revolution/min							回転速度 (min ⁻¹) revolution/min
		10	100	200	400	800	1,200	1,500	100
100	8	0.075	0.75	1.43	2.41	4.26	6.02	7.50	71.62
100	13	0.122	1.22	2.33	3.92	6.93	9.78	12.19	116.50
105	8	0.079	0.79	1.50	2.51	4.47	6.33	-	75.44
105	13	0.129	1.29	2.44	4.08	7.27	10.30	-	123.19
110	8	0.083	0.83	1.57	2.60	4.69	6.68	-	79.26
110	13	0.136	1.36	2.55	4.23	7.61	10.85	-	129.87
115	8	0.087	0.88	1.63	2.70	4.89	7.02	-	84.03
115	13	0.143	1.43	2.65	4.38	7.95	11.40	-	136.56
120	8	0.091	0.92	1.69	2.81	5.10	7.36	-	87.85
120	13	0.149	1.49	2.75	4.57	8.29	11.96	-	142.29

KG 規格は“並幅” (軽荷重用) と“広幅” (重荷重用) があります。ご用途に応じてお選び下さい。

KG STOCK GEARS has Wide-face width for Heavy load, and Standard-face width for Light load.

You are able to multiple choices for your suitable design from our wide range.

The above numerical values are equivalent to JGMA formulas as reference only.

動力の換算式は P26 をご参照ください。Please refer to the conversion fomulas of power on page P26.

Memo

目次
CONTENTS

インフォメーション
INFORMATION

ギヤボックス
GEAR BOXES

ノーバッキングギヤ
ANTI BACKLASH SPUR GEARS

歯研平歯
GROUND SPUR GEARS

平歯
SPUR GEARS

内歯
INTERNAL GEARS

歯ラック
GROUND RACKS

ラック
RACKS

へりかき・スクリューギヤ
HELICAL GEARS AND SCREW GEARS

ワーム・ワームホイール
WORMS AND WORM WHEELS

かみ歯
BEVEL GEARS

sprockets
sprockets

技術資料
REFERENCE DATA

平歯車 SPUR GEARS

モジュール 1.5 圧力角 20° (並歯)
MODULE 1.5 20° PRESSURE ANGLE FULL DEPTH TOOTH

JIS B 1702-1 (ISO) 9~10 級
System of accuracy : JIS B 1702-1(ISO) class 9-10



New 仕様変更 省スペース・軽量化。
Specification change Space-saving and weight saving.

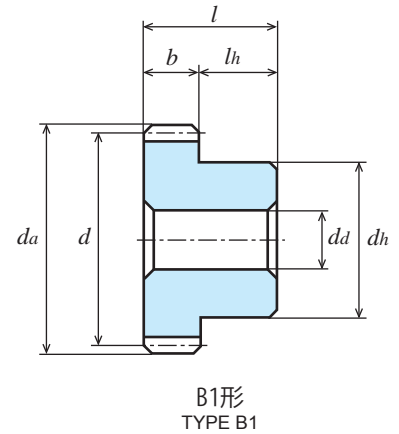
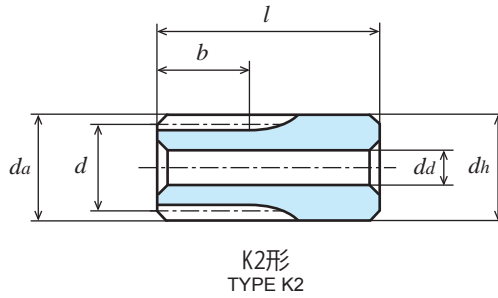

ポリアセタール (黒色)
Material : Poly Acetal (Black)

単位 : mm
Dimensions : mm

商品記号 Catalogue Number	歯数 Number of Teeth z	基準円直径 Reference Diameter d	歯先円直径 Tip Diameter da	形 Type	歯幅 Face Width b	穴径 Bore Diameter da	ハブ外径 Hub Diameter dh	ハブ長さ Hub Projection lh	全長 Overall Length l	重量 Weight $W(g)$
▲ S1.5D 14K - 1808	14	φ21	φ24	K2	18	φ 8	φ24	22	40	20.0
▲ S1.5D 15B - 1808N	15	φ22.5	φ25.5	B1	18	φ 8	φ18	10	28	11.7
▲ S1.5D 16B - 1808N	16	φ24	φ27	B1	18	φ 8	φ20	10	28	13.9
▲ S1.5D 18B - 1810N	18	φ27	φ30	B1	18	φ10	φ22	10	28	16.8
▲ S1.5D 20B - 1810N	20	φ30	φ33	B1	18	φ10	φ22	10	28	20.2
▲ S1.5D 24B - 1814N	24	φ36	φ39	B1	18	φ14	φ32	10	28	31.1
▲ S1.5D 25B - 1814N	25	φ37.5	φ40.5	B1	18	φ14	φ32	10	28	33.3
▲ S1.5D 28B - 1814N	28	φ42	φ45	B1	18	φ14	φ32	10	28	40.4
▲ S1.5D 30B - 1814N	30	φ45	φ48	B1	18	φ14	φ32	10	28	45.6
▲ S1.5D 32B - 1814N	32	φ48	φ51	B1	18	φ14	φ32	10	28	51.2
▲ S1.5D 35B - 1814N	35	φ52.5	φ55.5	B1	18	φ14	φ42	10	28	68.4
▲ S1.5D 36B - 1814N	36	φ54	φ57	B1	18	φ14	φ42	10	28	71.6

▲の商品は2017年5月20日をもってカタログ商品(規格品)としての生産を中止とします。米国・EU市場の食品接触用途・規制に適合した青 POM® ギヤシリーズをご利用ください。Products with ▲ mark will be terminated with effective 20th May 2017. Alternative products are indicated on separate catalogue of Blue Poly Acetal gears which adapted to relevant regulations for the food industries in the US and EU markets.

許容伝達動力表 曲げ強さ (W)

Allowable transfer capability table (W) Bending Strength

商品記号 Catalogue Numbers	回転速度 (min ⁻¹) revolution/min						
	10	100	200	400	800	1,200	1,500
S1.5D 14K - 1808	2.24	22.35	44.68	89.24	178.03	266.37	332.32
S1.5D 15B - 1808N	2.40	23.95	47.86	95.60	190.67	285.24	355.82
S1.5D 16B - 1808N	2.56	25.54	51.05	101.95	203.31	304.09	379.28
S1.5D 18B - 1810N	2.88	28.73	57.42	114.65	228.56	341.73	426.11
S1.5D 20B - 1810N	3.19	31.92	63.79	127.35	253.77	379.28	472.81
S1.5D 24B - 1814N	3.83	38.30	76.52	152.70	304.09	454.15	564.21
S1.5D 25B - 1814N	3.99	39.89	79.70	159.04	316.64	472.81	586.71
S1.5D 28B - 1814N	4.47	44.68	89.24	178.03	354.25	528.04	653.73
S1.5D 30B - 1814N	4.79	47.86	95.60	190.67	379.28	564.21	698.01
S1.5D 32B - 1814N	5.11	51.05	101.95	203.31	404.28	601.18	741.96
S1.5D 35B - 1814N	5.59	55.83	111.48	222.25	441.69	653.73	807.28
S1.5D 36B - 1814N	5.75	57.42	114.65	228.56	454.15	671.48	828.90

The above numerical values are Lewis formulas as reference only.

動力の換算式は P26 をご参照ください。

Please refer to the conversion formulas of power on page P26.

平歯車 SPUR GEARS

モジュール 1.5 圧力角 20° (並歯)
MODULE 1.5 20° PRESSURE ANGLE FULL DEPTH TOOTH

JIS B 1702-1 (ISO) 9~10 級
System of accuracy: JIS B 1702-1(ISO) class 9-10



御注文には必ず“フルネームで商品記号”を明記してください。
Please refer to the catalogue reference while ordering.

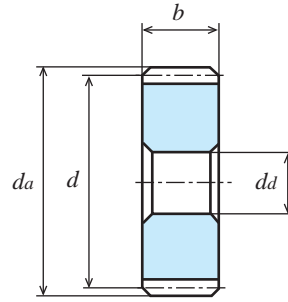

A1形
TYPE A1

ポリアセタール (黒色)
Material: Poly Acetal (Black)

単位: mm
Dimensions: mm

商品記号 Catalogue Number	歯数 Number of Teeth <i>z</i>	基準円直径 Reference Diameter <i>d</i>	歯先円直径 Tip Diameter <i>da</i>	形 Type	歯幅 Face Width <i>b</i>	穴径 Bore Diameter <i>da</i>	ハブ外径 Hub Diameter <i>dh</i>	ハブ長さ Hub Projection <i>lh</i>	全長 Overall Length <i>l</i>	重量 Weight <i>W(g)</i>
▲ S1.5D 40A - 1814	40	φ 60	φ 63	A1	18	φ14	-	-	18	67.9
▲ S1.5D 45A - 1814	45	φ 67.5	φ 70.5	A1	18	φ14	-	-	18	86.9
▲ S1.5D 48A - 1814	48	φ 72	φ 75	A1	18	φ14	-	-	18	99.4
▲ S1.5D 50A - 1814	50	φ 75	φ 78	A1	18	φ14	-	-	18	108.2
▲ S1.5D 56A - 1814	56	φ 84	φ 87	A1	18	φ14	-	-	18	136.7
▲ S1.5D 60A - 1814	60	φ 90	φ 93	A1	18	φ14	-	-	18	157.6
▲ S1.5D 64A - 1814	64	φ 96	φ 99	A1	18	φ14	-	-	18	179.8
▲ S1.5D 70A - 1814	70	φ105	φ108	A1	18	φ14	-	-	18	215.9
▲ S1.5D 72A - 1814	72	φ108	φ111	A1	18	φ14	-	-	18	228.6
▲ S1.5D 80A - 1816	80	φ120	φ123	A1	18	φ16	-	-	18	281.9
▲ S1.5D 90A - 1816	90	φ135	φ138	A1	18	φ16	-	-	18	358.2
▲ S1.5D 100A - 1816	100	φ150	φ153	A1	18	φ16	-	-	18	443.4

▲の商品は2017年5月20日をもってカタログ商品(規格品)としての生産を中止とします。米国・EU市場の食品接触用途・規制に適合した青 POM® ギヤシリーズをご利用ください。Products with ▲ mark will be terminated with effective 20th May 2017. Alternative products are indicated on separate catalogue of Blue Poly Acetal gears which adapted to relevant regulations for the food industries in the US and EU markets.

許容伝達動力表 曲げ強さ (W)

Allowable transfer capability table (W) Bending Strength

商品記号 Catalogue Numbers	回転速度 (min ⁻¹) revolution/min						
	10	100	200	400	800	1,200	1,500
S1.5D 40A - 1814	6.39	63.79	127.35	253.77	503.82	741.96	914.54
S1.5D 45A - 1814	7.19	71.74	143.20	285.24	564.21	828.90	1,017.93
S1.5D 48A - 1814	7.67	76.52	152.70	304.09	600.18	880.44	1,077.66
S1.5D 50A - 1814	7.99	79.70	159.04	316.64	624.04	914.54	1,116.92
S1.5D 56A - 1814	8.94	89.24	178.03	354.25	695.07	1,013.91	1,231.98
S1.5D 60A - 1814	9.58	95.60	190.67	379.28	741.96	1,077.66	1,306.42
S1.5D 64A - 1814	10.22	101.95	203.31	404.28	788.49	1,140.25	1,378.54
S1.5D 70A - 1814	11.18	111.48	222.25	441.69	857.59	1,231.98	1,473.90
S1.5D 72A - 1814	11.50	114.65	228.56	454.15	880.44	1,261.97	1,504.40
S1.5D 80A - 1816	12.78	127.35	253.77	503.82	970.77	1,378.54	1,619.93
S1.5D 90A - 1816	14.37	143.20	285.24	564.21	1,077.66	1,504.40	-
S1.5D 100A - 1816	15.97	159.04	316.64	624.04	1,181.34	1,619.93	-

The above numerical values are Lewis formulas as reference only.
動力の換算式は P26 をご参照ください。
Please refer to the conversion formulas of power on page P26.

目次
CONTENTS

インフォメーション
INFORMATION

ギヤボックス
GEAR BOXES

ノーバクシスギヤ
ANTI BACKLASH SPUR GEARS

歯研平歯車
GROUND SPUR GEARS

平歯車
SPUR GEARS

内歯車
INTERNAL GEARS

歯研ラック
GROUND RACKS

ラック
RACKS

ひかりスクリューギヤ
HELICAL GEARS AND SCREW GEARS

ウォーム
WORMS AND WORM WHEELS

かさ歯車
BEVEL GEARS

スプロケット
SPROCKETS

技術仕様
REFERENCE DATA

ステンレス平歯車

SPUR GEARS

モジュール **1.5** 圧力角 20° (並歯)
 MODULE 20° PRESSURE ANGLE FULL DEPTH TOOTH

JIS B 1702-1 (ISO) 9級
 System of accuracy: JIS B 1702-1(ISO) class 9



御注文には必ず“フルネームで商品記号”を明記してください。
 Please refer to the catalogue reference while ordering.

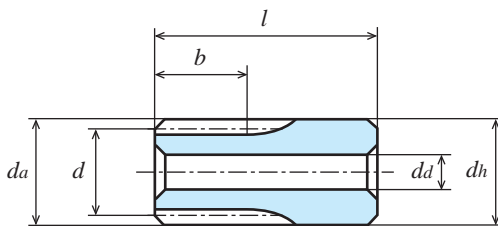

K2形
TYPE K2

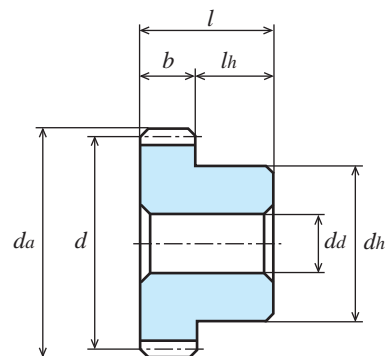

B1形
TYPE B1

SUS304 ステンレス鋼棒 (JIS G 4303)

Material: Stainless Steel SUS304 (JIS G 4303)

単位: mm
 Dimensions: mm

商品記号 Catalogue Number	歯数 Number of Teeth <i>z</i>	基準円直径 Reference Diameter <i>d</i>	歯先円直径 Tip Diameter <i>da</i>	形 Type	歯幅 Face Width <i>b</i>	穴径 Bore Diameter <i>da(H8)</i>	ハブ外径 Hub Diameter <i>dh</i>	ハブ長さ Hub Projection <i>lh</i>	全長 Overall Length <i>l</i>	重量 Weight <i>W(g)</i>
S1.5SU 14K - 1208	14	φ21	φ24	K2	12	φ 8	φ24	24	36	104.7
S1.5SU 15B - 1208	15	φ22.5	φ25.5	B1	12	φ 8	φ18	10	22	49.3
S1.5SU 15B - 1608N	15	φ22.5	φ25.5	B1	16	φ 8	φ18	10	26	60.3
S1.5SU 16B - 1208	16	φ24	φ27	B1	12	φ 8	φ20	10	22	59.2
S1.5SU 16B - 1608N	16	φ24	φ27	B1	16	φ 8	φ20	10	26	72.0
S1.5SU 18B - 1210	18	φ27	φ30	B1	12	φ10	φ22	10	22	70.9
S1.5SU 18B - 1610N	18	φ27	φ30	B1	16	φ10	φ22	10	26	86.6
S1.5SU 20B - 1210	20	φ30	φ33	B1	12	φ10	φ25	10	22	92.5
S1.5SU 20B - 1610N	20	φ30	φ33	B1	16	φ10	φ25	10	26	112.4
S1.5SU 24B - 1210	24	φ36	φ39	B1	12	φ10	φ30	10	22	139.2
S1.5SU 25B - 1210	25	φ37.5	φ40.5	B1	12	φ10	φ30	10	22	147.5
S1.5SU 25B - 1610N	25	φ37.5	φ40.5	B1	16	φ10	φ30	10	26	180.0
S1.5SU 28B - 1210	28	φ42	φ45	B1	12	φ10	φ30	10	22	174.2
S1.5SU 30B - 1210	30	φ45	φ48	B1	12	φ10	φ30	10	22	193.7
S1.5SU 30B - 1610N	30	φ45	φ48	B1	16	φ10	φ30	10	26	241.7

許容伝達動力表 曲げ強さ (W)

Allowable transfer capability table (W) Bending Strength

商品記号 Catalogue Numbers	回転速度 (min ⁻¹) revolution/min						
	10	100	200	400	800	1,200	1,500
S1.5SU 14K - 1208	5.98	59.75	119.51	239.02	478.04	684.27	816.77
S1.5SU 15B - 1208	6.70	66.97	133.93	267.86	535.73	756.63	900.82
S1.5SU 15B - 1608N	8.93	89.29	178.58	357.15	714.30	1,008.84	1,201.10
S1.5SU 16B - 1208	7.43	74.32	148.63	297.27	594.06	828.66	984.12
S1.5SU 16B - 1608N	9.91	99.09	198.18	396.36	792.08	1,104.88	1,312.16
S1.5SU 18B - 1210	8.93	89.34	178.67	357.35	700.93	970.64	1,147.22
S1.5SU 18B - 1610N	11.91	119.12	238.23	476.46	952.91	1,294.19	1,529.63
S1.5SU 20B - 1210	10.49	104.90	209.79	419.58	839.16	1,111.24	1,307.46
S1.5SU 20B - 1610N	13.99	139.86	279.72	559.44	1,077.41	1,481.65	1,743.28
S1.5SU 24B - 1210	13.67	136.75	273.50	546.99	1,016.53	1,379.79	1,609.91
S1.5SU 25B - 1210	14.49	144.89	289.77	579.54	1,067.67	1,444.72	1,682.38
S1.5SU 25B - 1610N	19.32	193.18	386.36	772.72	1,423.55	1,926.29	2,243.17
S1.5SU 28B - 1210	16.96	169.62	339.24	678.48	1,218.22	1,633.80	1,934.94
S1.5SU 30B - 1210	18.62	186.25	372.50	744.99	1,315.37	1,754.13	2,105.74
S1.5SU 30B - 1610N	24.83	248.33	496.66	993.32	1,753.83	2,338.85	2,807.65

The above numerical values are equivalent to JGMA formulas as reference only.

動力の換算式は P26 をご参照ください。

Please refer to the conversion formulas of power on page P26.

ステンレス平歯車

SPUR GEARS

モジュール **1.5** 圧力角 20° (並歯)
 MODULE 20° PRESSURE ANGLE FULL DEPTH TOOTH

JIS B 1702-1 (ISO) 9 級
 System of accuracy : JIS B 1702-1(ISO) class 9



御注文には必ず“フルネームで商品記号”を明記してください。
 Please refer to the catalogue reference while ordering.

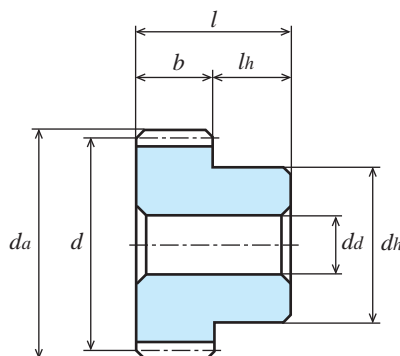

B1形
TYPE B1

SUS304 ステンレス鋼棒 (JIS G 4303)

Material : Stainless Steel SUS304 (JIS G 4303)

単位 : mm
 Dimensions : mm

商品記号 Catalogue Number	歯数 Number of Teeth <i>z</i>	基準円直径 Reference Diameter <i>d</i>	歯先円直径 Tip Diameter <i>da</i>	形 Type	歯幅 Face Width <i>b</i>	穴径 Bore Diameter <i>da</i> (H8)	ハブ外径 Hub Diameter <i>dh</i>	ハブ長さ Hub Projection <i>lh</i>	全長 Overall Length <i>l</i>	重量 Weight <i>W</i> (g)
S1.5SU 32B - 1010	32	φ 48	φ 51	B1	10	φ10	φ30	10	20	187.1
S1.5SU 36B - 1010	36	φ 54	φ 57	B1	10	φ10	φ30	10	20	225.2
S1.5SU 40B - 1012	40	φ 60	φ 63	B1	10	φ12	φ36	10	20	287.0
S1.5SU 45B - 1012	45	φ 67.5	φ 70.5	B1	10	φ12	φ36	10	20	346.6
S1.5SU 48B - 1012	48	φ 72	φ 75	B1	10	φ12	φ36	10	20	385.7
S1.5SU 50B - 1012	50	φ 75	φ 78	B1	10	φ12	φ42	10	20	442.3
S1.5SU 60B - 1014	60	φ 90	φ 93	B1	10	φ14	φ50	10	20	635.8
S1.5SU 80B - 1016	80	φ120	φ123	B1	10	φ16	φ60	10	20	1,089.0
S1.5SU 90B - 1016	90	φ135	φ138	B1	10	φ16	φ60	10	20	1,327.0
S1.5SU 100B - 1016	100	φ150	φ153	B1	10	φ16	φ60	10	20	1,594.0

許容伝達動力表 曲げ強さ (W)

Allowable transfer capability table (W) Bending Strength

商品記号 Catalogue Numbers	回転速度 (min ⁻¹) revolution/min						
	10	100	200	400	800	1,200	1,500
S1.5SU 32B - 1010	16.93	169.25	338.50	676.46	1,175.77	1,561.35	1,896.72
S1.5SU 36B - 1010	19.77	197.67	395.34	775.44	1,329.66	1,797.47	2,176.88
S1.5SU 40B - 1012	22.65	226.45	452.91	872.24	1,476.48	2,030.22	2,451.46
S1.5SU 45B - 1012	26.27	262.66	525.31	989.24	1,649.19	2,314.06	2,794.13
S1.5SU 48B - 1012	28.46	284.63	569.25	1,057.90	1,750.48	2,481.86	3,002.75
S1.5SU 50B - 1012	29.93	299.34	598.67	1,102.91	1,832.09	2,592.36	3,140.56
S1.5SU 60B - 1014	37.35	373.48	746.97	1,318.86	2,232.26	3,152.13	3,813.74
S1.5SU 80B - 1016	52.39	523.90	1,008.96	1,707.93	2,991.84	4,234.47	5,239.02
S1.5SU 90B - 1016	59.91	599.07	1,128.12	1,880.73	3,370.67	4,792.53	-
S1.5SU 100B - 1016	67.51	675.07	1,243.66	2,065.89	3,743.17	5,400.57	-

The above numerical values are equivalent to JGMA formulas as reference only.

動力の換算式は P26 をご参照ください。

Please refer to the conversion formulas of power on page P26.

目次
CONTENTS

インフォメーション
INFORMATION

ギヤボックス
GEAR BOXES

ノーバッキングギヤ
ANTI BACKLASH SPUR GEARS

歯研平歯車
GROUND SPUR GEARS

平歯車
SPUR GEARS

内歯車
INTERNAL GEARS

歯研ラック
GROUND RACKS

ラック
RACKS

へリカル・スクリューギヤ
HELICAL GEARS AND SCREW GEARS

ウォーム・ウォームギヤ
WORMS AND WORM GEARS

かさ歯車
BEVEL GEARS

スプロケット
SPROCKETS

技術資料
REFERENCE DATA

平歯車 SPUR GEARS

モジュール 1.5 圧力角 20° (並歯) 歯数 8 ~ 16
 MODULE 20° PRESSURE ANGLE FULL DEPTH TOOTH Z 8 to Z 16

JIS B 1702-1 (ISO) 8~9 級
 System of accuracy : JIS B 1702-1(ISO) class 8 - 9



New 仕様変更 省スペース・軽量化。
 Specification change Space-saving and weight saving.

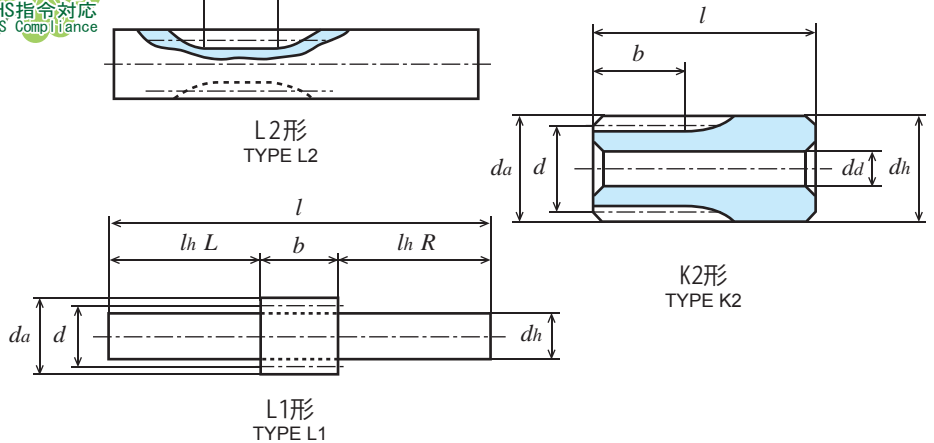

S45C 機械構造用炭素鋼 (JIS G 4051) *印を付した商品は転位歯車です。転位係数 x は 0.5 です。
 Material : Carbon Steel (ISO C45) * mark has been profile shifted gears. (Rack shift coefficient $x = 0.5$)

単位 : mm
 Dimensions : mm

商品記号 Catalogue Number	歯数 Number of Teeth z	基準円直径 Reference Diameter d	歯先円直径 Tip Diameter d_a	形 Type	歯幅 Face Width b	穴径 Bore Diameter $d_a(H7)$	ハブ外径 Hub Diameter d_h	ハブ長さ Hub Projection l_h	全長 Overall Length l	重量 Weight $W(g)$
S1.5S 8L-1809	8	*	$\phi 15.96$	L1	18	-	$\phi 9(h9)$	L24 R48	90	56.2
S1.5S 8L-1816F	8	*	$\phi 15.96$	L2	18	-	$\phi 15.96$	L24 R48	90	133.3
S1.5S 10L-1812	10	*	$\phi 19$	L1	18	-	$\phi 12(h9)$	L24 R48	90	94.1
S1.5S 10L-1819F	10	*	$\phi 19$	L2	18	-	$\phi 19$	L24 R48	90	190.5
S1.5S 12K-1808	12	$\phi 18$	$\phi 21$	K2	18	$\phi 8(H8)$	$\phi 21$	22	40	80.0
S1.5S 13K-1808	13	$\phi 19.5$	$\phi 22.5$	K2	18	$\phi 8(H8)$	$\phi 22.5$	22	40	95.1
S1.5S 14K-1808	14	$\phi 21$	$\phi 24$	K2	18	$\phi 8(H8)$	$\phi 24$	22	40	111.3
S1.5S 15A-1208	15	$\phi 22.5$	$\phi 25.5$	A1	12	$\phi 8$	-	-	12	32.7
S1.5S 15A-1808	15	$\phi 22.5$	$\phi 25.5$	A1	18	$\phi 8$	-	-	18	49.1
S1.5S 15B-1208	15	$\phi 22.5$	$\phi 25.5$	B1	12	$\phi 8$	$\phi 18$	10	22	48.8
S1.5S 15B-1608N	15	$\phi 22.5$	$\phi 25.5$	B1	16	$\phi 8(H8)$	$\phi 17$	10	26	57.5
S1.5S 15B-1808N	15	$\phi 22.5$	$\phi 25.5$	B1	18	$\phi 8(H8)$	$\phi 18$	10	28	65.2
S1.5S 16A-1208	16	$\phi 24$	$\phi 27$	A1	12	$\phi 8$	-	-	12	37.9
S1.5S 16A-1608	16	$\phi 24$	$\phi 27$	A1	16	$\phi 8$	-	-	16	50.5
S1.5S 16A-1808	16	$\phi 24$	$\phi 27$	A1	18	$\phi 8$	-	-	18	56.8
S1.5S 16B-1208	16	$\phi 24$	$\phi 27$	B1	12	$\phi 8$	$\phi 20$	10	22	58.6
S1.5S 16B-1608N	16	$\phi 24$	$\phi 27$	B1	16	$\phi 8(H8)$	$\phi 18$	10	26	66.6
S1.5S 16B-1808N	16	$\phi 24$	$\phi 27$	B1	18	$\phi 8(H8)$	$\phi 20$	10	28	77.6

許容伝達動力表 曲げ強さ (kW)

T (N · m)

Allowable transfer capability table (kW) Bending Strength

歯数 z	歯幅 b	回転速度 (min ⁻¹) revolution/min							回転速度 (min ⁻¹) revolution/min
		10	100	200	400	800	1,200	1,500	
8	18	0.010	0.108	0.216	0.433	0.867	1.301	1.619	10.31
10	18	0.014	0.149	0.299	0.598	1.197	1.791	2.156	14.22
12	18	0.013	0.137	0.275	0.550	1.100	1.618	1.942	13.08
13	18	0.015	0.158	0.316	0.632	1.264	1.835	2.196	15.08
14	18	0.017	0.179	0.358	0.717	1.434	2.052	2.450	17.09
15	12	0.013	0.133	0.267	0.535	1.071	1.513	1.801	12.70
15	16	0.017	0.178	0.357	0.714	1.428	2.017	2.402	16.99
15	18	0.020	0.200	0.401	0.803	1.607	2.269	2.702	19.09
16	12	0.014	0.148	0.297	0.594	1.188	1.657	1.968	14.13
16	16	0.019	0.198	0.396	0.792	1.584	2.209	2.624	18.90
16	18	0.022	0.222	0.445	0.891	1.782	2.485	2.952	21.20

The above numerical values are equivalent to JGMA formulas as reference only.

動力の換算式は P26 をご参照ください。Please refer to the conversion fomulas of power on page P26.

平歯車

SPUR GEARS

モジュール
MODULE

1.5

圧力角 20° (並歯) 歯数 17 ~ 19
20° PRESSURE ANGLE FULL DEPTH TOOTH Z 17 to Z 19

JIS B 1702-1 (ISO) 8 級
System of accuracy : JIS B 1702-1(ISO) class 8



御注文には必ず“フルネームで商品記号”を明記してください。
Please refer to the catalogue reference while ordering.

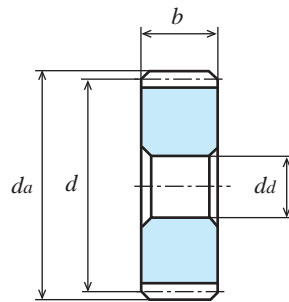

A1形
TYPE A1

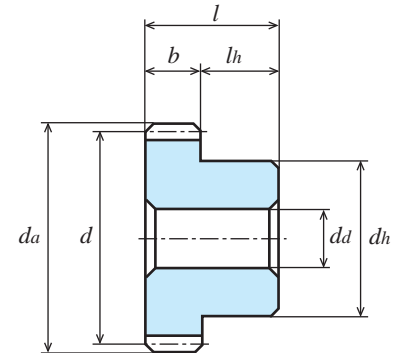

B1形
TYPE B1

S45C 機械構造用炭素鋼 (JIS G 4051)

Material : Carbon Steel (ISO C45)

単位 : mm
Dimensions : mm

商品記号 Catalogue Number	歯数 Number of Teeth z	基準円直径 Reference Diameter d	歯先円直径 Tip Diameter da	形 Type	歯幅 Face Width b	穴径 Bore Diameter da(H7)	ハブ外径 Hub Diameter dh	ハブ長さ Hub Projection lh	全長 Overall Length l	キーマイ Key Way b ₂ × t ₂	重量 Weight W(g)
S1.5S 17B - 1208F	17	φ25.5	φ28.5	B1	12	φ 8	φ20	10	22	-	64.1
S1.5S 17B - 1808	17	φ25.5	φ28.5	B1	18	φ 8(H8)	φ20	10	28	-	85.8
S1.5S 18A - 1210F	18	φ27	φ30	A1	12	φ10	-	-	12	-	46.5
S1.5S 18A - 1610F	18	φ27	φ30	A1	16	φ10	-	-	16	-	62.1
S1.5S 18A - 1810F	18	φ27	φ30	A1	18	φ10	-	-	18	-	69.8
S1.5S 18B - 1210F	18	φ27	φ30	B1	12	φ10	φ22	10	22	-	70.2
S1.5S 18B - 1610	18	φ27	φ30	B1	16	φ10	φ21	10	26	-	83.1
S1.5S 18B - 1810	18	φ27	φ30	B1	18	φ10	φ22	10	28	-	93.5
S1.5S 19A - 1210F	19	φ28.5	φ31.5	A1	12	φ10	-	-	12	-	52.7
S1.5S 19A - 1810F	19	φ28.5	φ31.5	A1	18	φ10	-	-	18	-	79.0
S1.5S 19B - 1210F	19	φ28.5	φ31.5	B1	12	φ10	φ24	10	22	-	82.0
S1.5S 19B - 1810	19	φ28.5	φ31.5	B1	18	φ10	φ24	10	28	-	108.5

許容伝達動力表 曲げ強さ (kW)

Allowable transfer capability table (kW) Bending Strength

T (N · m)

歯数 z	歯幅 b	回転速度 (min ⁻¹) revolution/min							回転速度 (min ⁻¹) revolution/min
		10	100	200	400	800	1,200	1,500	
17	12	0.016	0.164	0.327	0.654	1.295	1.800	2.133	15.66
17	18	0.024	0.245	0.490	0.981	1.942	2.700	3.198	23.39
18	12	0.017	0.178	0.357	0.714	1.401	1.941	2.294	16.99
18	16	0.023	0.238	0.476	0.952	1.869	2.588	3.059	22.72
18	18	0.026	0.268	0.536	1.072	2.102	2.911	3.441	25.59
19	12	0.019	0.194	0.388	0.776	1.509	2.083	2.456	18.52
19	18	0.029	0.291	0.582	1.165	2.264	3.125	3.685	27.78

KG 規格は“並幅” (軽荷重用) と“広幅” (重荷重用) があります。ご用途に応じてお選び下さい。

KG STOCK GEARS has Wide-face width for Heavy load, and Standard-face width for Light load.

You are able to multiple choices for your suitable design from our wide range.

The above numerical values are equivalent to JGMA formulas as reference only.

動力の換算式は P26 をご参照ください。Please refer to the conversion fomulas of power on page P26.

目次
CONTENTS

インフォメーション
INFORMATION

ギヤボックス
GEAR BOXES

ノーバッキングギヤ
ANTI BACKLASH SPUR GEARS

歯研平歯車
GROUND SPUR GEARS

平歯車
SPUR GEARS

内歯車
INTERNAL GEARS

歯研ラック
GROUND RACKS

ラック
RACKS

へリカル・スクリューギヤ
HELICAL GEARS AND SCREW GEARS

ウォーム・ウォームギヤ
WORMS AND WORM GEARS

かさ歯車
BEVEL GEARS

スプロケット
SPROCKETS

技術資料
REFERENCE DATA

平歯車 SPUR GEARS

モジュール 1.5 圧力角 20° (並歯) 歯数 20
MODULE 20° PRESSURE ANGLE FULL DEPTH TOOTH Z 20

JIS B 1702-1 (ISO) 8級 (高周波焼入品: 9級)
System of accuracy: JIS B 1702-1(ISO) class 8
(Induction hardened products: class 9)



New 仕様変更 省スペース・軽量化、締結加工不要。
Specification change Space-saving and weight saving.
Additional machining on tightening is not necessary.

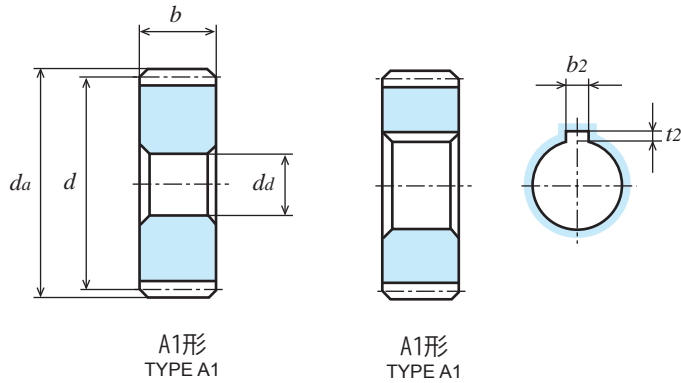

S45C 機械構造用炭素鋼 (JIS G 4051) Material: Carbon Steel (ISO C45)

単位: mm
Dimensions: mm

商品記号 Catalogue Number	歯数 Number of Teeth z	基準円直径 Reference Diameter d	歯先円直径 Outside Diameter da	形 Type	歯幅 Face Width b	穴径 Bore Diameter da(H7)	ハブ外径 Hub Diameter dh	ハブ長さ Hub Projection lh	全長 Overall Length l	キミぞ Key Way b2 × t2	ねじ Set Screw		リム内径 Dimension of Rim di	ウェブ厚さ Thickness of Web bw	重量 Weight W(g)
											M	ls			
S1.5S 20A - 1010F	20	φ30	φ33	A1	10	φ10	-	-	10	-	-	-	-	49.3	
S1.5S 20A - 1210F	20	φ30	φ33	A1	12	φ10	-	-	12	-	-	-	-	59.2	
S1.5S 20A = 1212	20	φ30	φ33	A1	12	φ12	-	-	12	4 × 1.8	-	-	-	55.3	
S1.5S 20A = 1215	20	φ30	φ33	A1	12	φ15	-	-	12	5 × 2.3	-	-	-	48.9	
S1.5S 20A - 1610F	20	φ30	φ33	A1	16	φ10	-	-	16	-	-	-	-	78.9	
S1.5S 20A - 1810F	20	φ30	φ33	A1	18	φ10	-	-	18	-	-	-	-	88.8	
S1.5S 20A = 1812	20	φ30	φ33	A1	18	φ12	-	-	18	4 × 1.8	-	-	-	82.9	
S1.5S 20A = 1815	20	φ30	φ33	A1	18	φ15	-	-	18	5 × 2.3	-	-	-	73.3	
S1.5S 20B - 1010F	20	φ30	φ33	B1	10	φ10	φ24	10	20	-	-	-	-	78.7	
S1.5S 20B - 1210F	20	φ30	φ33	B1	12	φ10	φ25	10	22	-	-	-	-	91.6	
S1.5S 20B # 1212	20	φ30	φ33	B1	12	φ12	φ25	10	22	4 × 1.8	M3	5	-	84.2	
S1.5S 20B # 1215	20	φ30	φ33	B1	12	φ15	φ25	10	22	5 × 2.3	M3	5	-	72.5	
S1.5S 20BF - 1506	20	φ30	φ33	B1	15	φ 6(H8)	φ25	15	30	-	-	-	-	113.1	
S1.5S 20B - 1506H	20	φ30	φ33	B1	15	φ 6(H※)	φ25	15	30	-	-	-	-	113.1	
S1.5S 20B - 1610	20	φ30	φ33	B1	16	φ10	φ24	10	26	-	-	-	-	111.4	
S1.5S 20B - 1810	20	φ30	φ33	B1	18	φ10	φ25	10	28	-	-	-	-	121.2	
S1.5S 20B # 1812	20	φ30	φ33	B1	18	φ12	φ25	10	28	4 × 1.8	M3	5	-	111.8	
S1.5S 20B # 1815	20	φ30	φ33	B1	18	φ15	φ25	10	28	5 × 2.3	M3	5	-	96.9	

●の商品は新商品です。Products with ● marks are new item.

【=】(イコール)にはキー材が付いております。 [=]: Gear with key way / with key

【#】(シャープ)にはキー材とセットスクリューが付いております。 [#]: Gear with key way and threaded hole / with key and screw.

カタログ記号の末尾に【H】を付した商品は歯部高周波焼入済です。 Gear tooth surface completed with induction hardening, Hardness HRC47 to 53.

※ 歯部高周波焼入後の穴修正は行っていません。 Bore correcting after induction hardening is not completed.

追加加工の際は、追加加工時の注意をご参照ください。 Please refer to Precaution for additional process when additional process.

許容伝達動力表 曲げ強さ (kW)

Allowable transfer capability table (kW) Bending Strength

歯数 z	歯幅 b	焼入 H	回転速度 (min ⁻¹) revolution/min						
			10	100	200	400	800	1,200	1,500
20	10	-	0.017	0.174	0.349	0.699	1.346	1.852	2.179
20	12	-	0.020	0.209	0.419	0.839	1.616	2.222	2.614
20	15	-	0.026	0.260	0.530	1.060	2.030	2.800	3.290
20	15	○	0.028	0.280	0.560	1.120	2.165	2.999	3.545
20	16	-	0.027	0.279	0.559	1.118	2.154	2.963	3.486
20	18	-	0.031	0.314	0.629	1.258	2.424	3.333	3.922

The above numerical values are equivalent to JGMA formulas as reference only.

動力の換算式はP26をご参照ください。 Please refer to the conversion formulas of power on page P26.

許容伝達動力表 歯面強さ (kW)

Allowable transfer capability table (kW) Surface Durability

回転速度 (min ⁻¹) revolution/min						
10	100	200	400	800	1,200	1,500
-	-	-	-	-	-	-
-	-	-	-	-	-	-
0.001	0.010	0.020	0.050	0.090	0.130	0.150
0.056	0.116	0.239	0.477	0.673	0.803	-
-	-	-	-	-	-	-
-	-	-	-	-	-	-

平歯車

SPUR GEARS

モジュール **1.5** 圧力角 20° (並歯) 歯数 21 ~ 23
 MODULE 20° PRESSURE ANGLE FULL DEPTH TOOTH Z 21 to Z 23

JIS B 1702-1 (ISO) 8 級
 System of accuracy : JIS B 1702-1(ISO) class 8



御注文には必ず“フルネームで商品記号”を明記してください。
 Please refer to the catalogue reference while ordering.

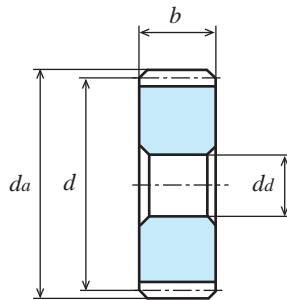

A1形
TYPE A1

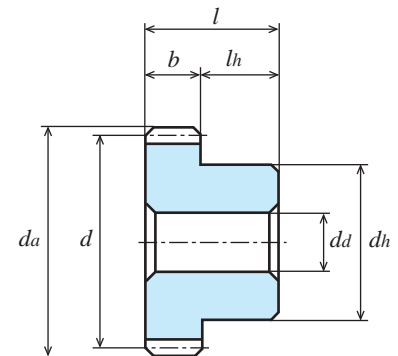

B1形
TYPE B1

S45C 機械構造用炭素鋼 (JIS G 4051)

Material : Carbon Steel (ISO C45)

単位 : mm
 Dimensions : mm

商品記号 Catalogue Number	歯数 Number of Teeth z	基準円直径 Reference Diameter d	歯先円直径 Tip Diameter da	形 Type	歯幅 Face Width b	穴径 Bore Diameter da(H7)	ハブ外径 Hub Diameter dh	ハブ長さ Hub Projection lh	全長 Overall Length l	キミぞ Key Way b ₂ × t ₂	重量 Weight W(g)
S1.5S 21A - 1210F	21	φ31.5	φ34.5	A1	12	φ10	-	-	12	-	66.0
S1.5S 21A - 1810F	21	φ31.5	φ34.5	A1	18	φ10	-	-	18	-	99.0
S1.5S 21B - 1210F	21	φ31.5	φ34.5	B1	12	φ10	φ26	10	22	-	101.5
S1.5S 21B - 1810	21	φ31.5	φ34.5	B1	18	φ10	φ26	10	28	-	134.6
S1.5S 22A - 1210F	22	φ33	φ36	A1	12	φ10	-	-	12	-	73.2
S1.5S 22A - 1810F	22	φ33	φ36	A1	18	φ10	-	-	18	-	109.8
S1.5S 22B - 1210F	22	φ33	φ36	B1	12	φ10	φ26	10	22	-	108.7
S1.5S 22B - 1810	22	φ33	φ36	B1	18	φ10	φ26	10	28	-	145.4
S1.5S 23A - 1210F	23	φ34.5	φ37.5	A1	12	φ10	-	-	12	-	80.7
S1.5S 23A - 1810F	23	φ34.5	φ37.5	A1	18	φ10	-	-	18	-	121.0
S1.5S 23B - 1210F	23	φ34.5	φ37.5	B1	12	φ10	φ26	10	22	-	116.2
S1.5S 23B - 1810	23	φ34.5	φ37.5	B1	18	φ10	φ28	10	28	-	163.3

許容伝達動力表 曲げ強さ (kW)

Allowable transfer capability table (kW) Bending Strength

T (N · m)

歯数 z	歯幅 b	回転速度 (min ⁻¹) revolution/min							回転速度 (min ⁻¹) revolution/min
		10	100	200	400	800	1,200	1,500	
21	12	0.022	0.225	0.450	0.901	1.781	2.359	2.769	100
21	18	0.033	0.338	0.676	1.352	2.582	3.538	4.154	21.48
22	12	0.024	0.241	0.482	0.965	1.826	2.494	2.922	32.27
22	18	0.036	0.362	0.724	1.448	2.739	3.742	4.384	23.01
23	12	0.025	0.257	0.514	1.029	1.930	2.628	3.073	34.56
23	18	0.038	0.386	0.772	1.544	2.895	3.943	4.610	24.54
									36.86

KG 規格は“並幅” (軽荷重用) と“広幅” (重荷重用) があります。ご用途に応じてお選び下さい。

KG STOCK GEARS has Wide-face width for Heavy load, and Standard-face width for Light load.

You are able to multiple choices for your suitable design from our wide range.

The above numerical values are equivalent to JGMA formulas as reference only.

動力の換算式は P26 をご参照ください。Please refer to the conversion fomulas of power on page P26.

平歯車 SPUR GEARS

モジュール **1.5** 圧力角 20° (並歯) 歯数 24
 MODULE 20° PRESSURE ANGLE FULL DEPTH TOOTH Z 24

JIS B 1702-1 (ISO) 8級
 System of accuracy : JIS B 1702-1(ISO) class 8



New 仕様変更 省スペース・軽量化、締結加工不要。
 Specification change Space-saving and weight saving.
 Additional machining on tightening is not necessary.

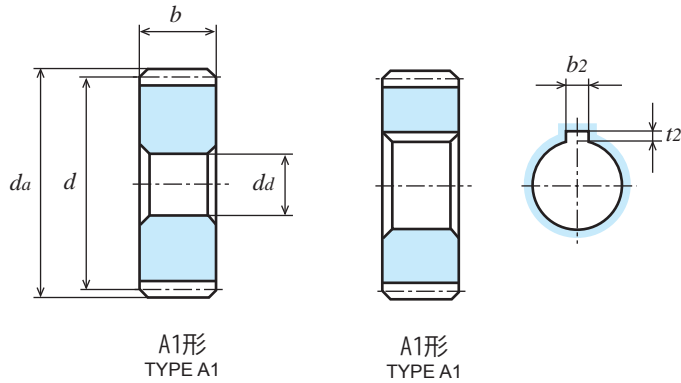

S45C 機械構造用炭素鋼 (JIS G 4051) Material : Carbon Steel (ISO C45)

単位 : mm
 Dimensions : mm

商品記号 Catalogue Number	歯数 Number of Teeth z	基準円直径 Reference Diameter d	歯先円直径 Outside Diameter da	形 Type	歯幅 Face Width b	穴径 Bore Diameter da(H7)	ハブ外径 Hub Diameter dh	ハブ長さ Hub Projection lh	全長 Overall Length l	キミぞ Key Way b ₂ × t ₂	ねじ Set Screw		リム内径 Dimension of Rim di	ウェブ厚さ Thickness of Web bw	重量 Weight W(g)
											M	ls			
S1.5S 24A - 1010F	24	φ36	φ39	A1	10	φ10	-	-	10	-	-	-	-	-	73.7
S1.5S 24A - 1210F	24	φ36	φ39	A1	12	φ10	-	-	12	-	-	-	-	-	88.5
S1.5S 24A = 1212	24	φ36	φ39	A1	12	φ12	-	-	12	4 × 1.8	-	-	-	-	84.6
S1.5S 24A = 1215	24	φ36	φ39	A1	12	φ15	-	-	12	5 × 2.3	-	-	-	-	78.2
S1.5S 24A - 1610F	24	φ36	φ39	A1	16	φ10	-	-	16	-	-	-	-	-	118.0
S1.5S 24A - 1812F	24	φ36	φ39	A1	18	φ12	-	-	18	-	-	-	-	-	127.8
S1.5S 24A = 1815	24	φ36	φ39	A1	18	φ15	-	-	18	5 × 2.3	-	-	-	-	117.2
S1.5S 24A = 1816	24	φ36	φ39	A1	18	φ16	-	-	18	5 × 2.3	-	-	-	-	113.8
S1.5S 24B - 1010F	24	φ36	φ39	B1	10	φ10	φ30	10	20	-	-	-	-	-	123.1
S1.5S 24B - 1210F	24	φ36	φ39	B1	12	φ10	φ30	10	22	-	-	-	-	-	137.8
S1.5S 24B # 1212	24	φ36	φ39	B1	12	φ12	φ30	10	22	4 × 1.8	M3	5	-	-	130.4
S1.5S 24B # 1215	24	φ36	φ39	B1	12	φ15	φ30	10	22	5 × 2.3	M4	5	-	-	118.5
S1.5S 24B - 1612	24	φ36	φ39	B1	16	φ12	φ30	10	26	-	-	-	-	-	160.4
S1.5S 24B - 1812	24	φ36	φ39	B1	18	φ12	φ30	10	28	-	-	-	-	-	174.6
S1.5S 24B # 1815	24	φ36	φ39	B1	18	φ15	φ30	10	28	5 × 2.3	M4	5	-	-	157.6
S1.5S 24B # 1816	24	φ36	φ39	B1	18	φ16	φ30	10	28	5 × 2.3	M4	5	-	-	152.3

[=] (イコール) にはキヤ材が付いております。 [=] : Gear with key way / with key
 [#] (シャープ) にはキヤ材とセットスクリューが付いております。 [#] : Gear with key way and threaded hole / with key and screw.

許容伝達動力表 曲げ強さ (kW)

Allowable transfer capability table (kW) Bending Strength

歯数 z	歯幅 b	回転速度 (min ⁻¹) revolution/min							回転速度 (min ⁻¹) revolution/min
		10	100	200	400	800	1,200	1,500	
24	10	0.022	0.227	0.455	0.911	1.694	2.299	2.683	100
24	12	0.027	0.273	0.546	1.093	2.033	2.759	3.219	21.67
24	16	0.036	0.364	0.729	1.458	2.710	3.679	4.293	26.07
24	18	0.041	0.410	0.820	1.640	3.049	4.139	4.829	34.76
									39.15

The above numerical values are equivalent to JGMA formulas as reference only.
 動力の換算式は P26 をご参照ください。 Please refer to the conversion fomulas of power on page P26.

平歯車

SPUR GEARS

モジュール **1.5** 圧力角 20° (並歯) 歯数 25
 MODULE 20° PRESSURE ANGLE FULL DEPTH TOOTH Z 25

JIS B 1702-1 (ISO) 8級 (高周波焼入品: 9級)
 System of accuracy: JIS B 1702-1(ISO) class 8
 (Induction hardened products: class 9)



御注文には必ず“フルネームで商品記号”を明記してください。

Please refer to the catalogue reference while ordering.

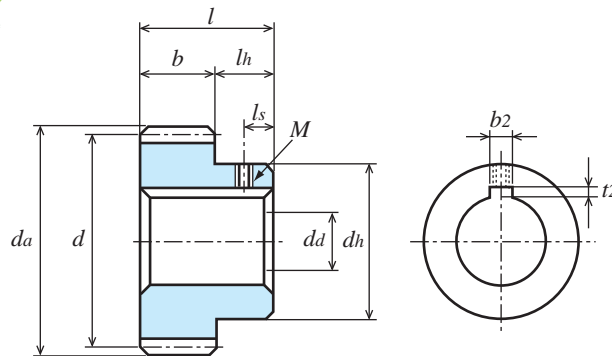

B1形
TYPE B1

S45C 機械構造用炭素鋼 (JIS G 4051) Material: Carbon Steel (ISO C45)

単位: mm
 Dimensions: mm

商品記号 Catalogue Number	歯数 Number of Teeth z	基準円直径 Reference Diameter d	歯先円直径 Outside Diameter da	形 Type	歯幅 Face Width b	穴径 Bore Diameter da(H7)	ハブ外径 Hub Diameter dh	ハブ長さ Hub Projection lh	全長 Overall Length l	キミぞ Key Way b2 × t2	ねじ Set Screw		リム内径 Dimension of Rim di	ウェブ厚さ Thickness of Web bw	重量 Weight W(g)
											M	ls			
S1.5S 25A - 1010F	25	φ37.5	φ40.5	A1	10	φ10	-	-	10	-	-	-	-	80.5	
S1.5S 25A - 1210F	25	φ37.5	φ40.5	A1	12	φ10	-	-	12	-	-	-	-	96.6	
S1.5S 25A = 1212	25	φ37.5	φ40.5	A1	12	φ12	-	-	12	4 × 1.8	-	-	-	92.7	
S1.5S 25A = 1215	25	φ37.5	φ40.5	A1	12	φ15	-	-	12	5 × 2.3	-	-	-	86.3	
S1.5S 25A - 1612F	25	φ37.5	φ40.5	A1	16	φ12	-	-	16	-	-	-	-	124.5	
S1.5S 25A - 1812F	25	φ37.5	φ40.5	A1	18	φ12	-	-	18	-	-	-	-	140.1	
S1.5S 25A = 1815	25	φ37.5	φ40.5	A1	18	φ15	-	-	18	5 × 2.3	-	-	-	129.5	
S1.5S 25A = 1816	25	φ37.5	φ40.5	A1	18	φ16	-	-	18	5 × 2.3	-	-	-	126.0	
S1.5S 25B - 1010F	25	φ37.5	φ40.5	B1	10	φ10	φ30	10	20	-	-	-	-	129.9	
S1.5S 25B - 1210	25	φ37.5	φ40.5	B1	12	φ10	φ30	10	22	-	-	-	-	146.1	
S1.5S 25B # 1212	25	φ37.5	φ40.5	B1	12	φ12	φ30	10	22	4 × 1.8	M3	5	-	138.5	
S1.5S 25B # 1215	25	φ37.5	φ40.5	B1	12	φ15	φ30	10	22	5 × 2.3	M4	5	-	126.7	
● S1.5S 25BF - 1508	25	φ37.5	φ40.5	B1	15	φ 8(H8)	φ30	15	30	-	-	-	-	200.0	
● S1.5S 25B - 1508H	25	φ37.5	φ40.5	B1	15	φ 8(H※)	φ30	15	30	-	-	-	-	200.0	
S1.5S 25B - 1612	25	φ37.5	φ40.5	B1	16	φ12	φ30	10	26	-	-	-	-	171.2	
S1.5S 25B - 1812	25	φ37.5	φ40.5	B1	18	φ12	φ32	10	28	-	-	-	-	194.5	
S1.5S 25B # 1815	25	φ37.5	φ40.5	B1	18	φ15	φ32	10	28	5 × 2.3	M4	5	-	177.4	
S1.5S 25B # 1816	25	φ37.5	φ40.5	B1	18	φ16	φ32	10	28	5 × 2.3	M4	5	-	172.1	
S1.5S 25B # 1818	25	φ37.5	φ40.5	B1	18	φ18	φ32	10	28	6 × 2.8	M4	5	-	159.3	

●の商品は新商品です。Products with ● marks are new item.

【=】(イコール)にはキー材が付いております。 [=]: Gear with key way / with key

【#】(シャープ)にはキー材とセットスクリューが付いております。[#]: Gear with key way and threaded hole / with key and screw.

カタログ記号の末尾に【H】を付した商品は歯部高周波焼入済です。Gear tooth surface completed with induction hardening, Hardness HRC47 to 53.

※

歯部高周波焼入後の穴修正は行っていません。Bore correcting after induction hardening is not completed.

追加加工の際は、追加加工時の注意をご参照ください。Please refer to Precaution for additional process when additional process.

許容伝達動力表 曲げ強さ (kW)

Allowable transfer capability table (kW) Bending Strength

歯数 z	歯幅 b	焼入 H	回転速度 (min ⁻¹) revolution/min						
			10	100	200	400	800	1,200	1,500
25	10	-	0.024	0.241	0.482	0.965	1.779	2.407	2.803
25	12	-	0.028	0.289	0.579	1.159	2.135	2.889	3.364
25	15	-	0.036	0.360	0.730	1.450	2.680	3.620	4.220
25	15	○	0.039	0.385	0.771	1.541	2.860	3.903	4.568
25	16	-	0.038	0.386	0.772	1.545	2.847	3.852	4.486
25	18	-	0.043	0.434	0.869	1.738	3.203	4.334	4.047

The above references are JGMA standard.

動力の換算式はP26をご参照ください。Please refer to the conversion formulas of power on page P26.

許容伝達動力表 歯面強さ (kW)

Allowable transfer capability table (kW) Surface Durability

回転速度 (min ⁻¹) revolution/min						
10	100	200	400	800	1,200	1,500
-	-	-	-	-	-	-
-	-	-	-	-	-	-
0.002	0.020	0.040	0.070	0.140	0.190	0.230
0.008	0.090	0.185	0.382	0.731	1.015	1.200
-	-	-	-	-	-	-
-	-	-	-	-	-	-

目次
CONTENTS

インフォメーション
INFORMATION

ギヤボックス
GEAR BOXES

ノーバッキングギヤ
ANTI BACKLASH SPUR GEARS

歯研削歯車
GROUND SPUR GEARS

平歯車
SPUR GEARS

内歯車
INTERNAL GEARS

歯ラック
GROUND RACKS

ラック
RACKS

ワーム・スクリューギヤ
HELIICAL GEARS AND SCREW GEARS

ウォーム・ウォームホイール
WORMS AND WORM WHEELS

かさ歯車
BEVEL GEARS

スプロケット
SPROCKETS

技術資料
REFERENCE DATA

平歯車 SPUR GEARS

モジュール 1.5 圧力角 20° (並歯) 歯数 26 27
 MODULE 20° PRESSURE ANGLE FULL DEPTH TOOTH Z 26 to Z 27

JIS B 1702-1 (ISO) 8級
 System of accuracy : JIS B 1702-1(ISO) class 8



New 仕様変更 省スペース・軽量化。
 Specification change Space-saving and weight saving.

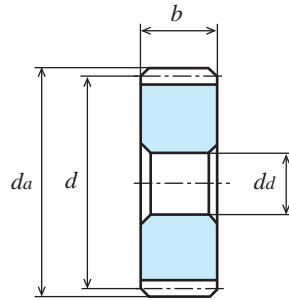

A1形
TYPE A1

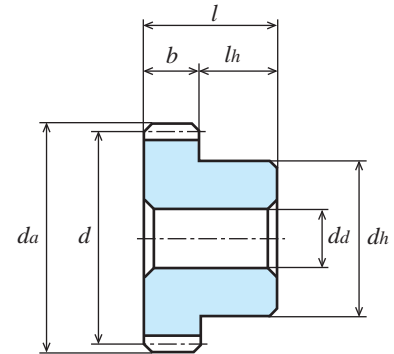

B1形
TYPE B1

S45C 機械構造用炭素鋼 (JIS G 4051) Material : Carbon Steel (ISO C45)

単位 : mm
 Dimensions : mm

商品記号 Catalogue Number	歯数 Number of Teeth z	基準円直径 Reference Diameter d	歯先円直径 Tip Diameter da	形 Type	歯幅 Face Width b	穴径 Bore Diameter da(H7)	ハブ外径 Hub Diameter dh	ハブ長さ Hub Projection lh	全長 Overall Length l	キミぞ Key Way b ₂ × t ₂	重量 Weight W(g)
S1.5S 26A - 1210F	26	φ39	φ42	A1	12	φ10	-	-	12	-	105.1
S1.5S 26A - 1812F	26	φ39	φ42	A1	18	φ12	-	-	18	-	152.8
S1.5S 26B - 1210F	26	φ39	φ42	B1	12	φ10	φ32	10	22	-	162.1
S1.5S 26B - 1812	26	φ39	φ42	B1	18	φ12	φ32	10	28	-	207.2
S1.5S 27A - 1210F	27	φ40.5	φ43.5	A1	12	φ10	-	-	12	-	114.0
S1.5S 27A - 1812F	27	φ40.5	φ43.5	A1	18	φ12	-	-	18	-	166.0
S1.5S 27B - 1210F	27	φ40.5	φ43.5	B1	12	φ10	φ32	10	22	-	170.9
S1.5S 27B - 1812	27	φ40.5	φ43.5	B1	18	φ12	φ36	10	28	-	237.2

許容伝達動力表 曲げ強さ (kW)

T (N · m)

Allowable transfer capability table (kW) Bending Strength

歯数 z	歯幅 b	回転速度 (min ⁻¹) revolution/min							回転速度 (min ⁻¹) revolution/min
		10	100	200	400	800	1,200	1,500	
26	12	0.030	0.306	0.612	1.224	2.236	3.017	3.524	29.22
26	18	0.045	0.459	0.918	1.836	3.355	4.526	5.286	43.83
27	12	0.032	0.322	0.645	1.290	2.337	3.143	3.697	30.75
27	18	0.048	0.483	0.967	1.935	3.505	4.715	5.545	46.12

The above numerical values are equivalent to JGMA formulas as reference only.

動力の換算式は P26 をご参照ください。Please refer to the conversion fomulas of power on page P26.

平歯車

SPUR GEARS

モジュール
MODULE

1.5

圧力角 20° (並歯)
20° PRESSURE ANGLE FULL DEPTH TOOTH

歯数 28 29

Z 28 to Z 29

JIS B 1702-1 (ISO) 8 級
System of accuracy : JIS B 1702-1(ISO) class 8



御注文には必ず“フルネームで商品記号”を明記してください。

Please refer to the catalogue reference while ordering.

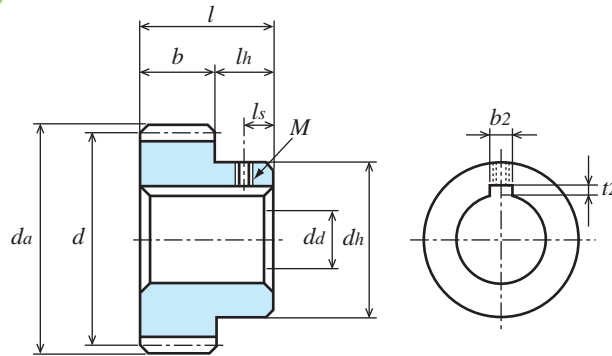

B1形
TYPE B1

S45C 機械構造用炭素鋼 (JIS G 4051) Material : Carbon Steel (ISO C45)

単位 : mm
Dimensions : mm

商品記号 Catalogue Number	歯数 Number of Teeth z	基準円直径 Reference Diameter d	歯先円直径 Outside Diameter da	形 Type	歯幅 Face Width b	穴径 Bore Diameter da(H7)	ハブ外径 Hub Diameter dh	ハブ長さ Hub Projection lh	全長 Overall Length l	キミぞ Key Way b2 × t2	ねじ Set Screw		リム内径 Dimension of Rim di	ウエブ厚さ Thickness of Web bw	重量 Weight W(g)
											M	ls			
S1.5S 28A - 1012F	28	φ42	φ45	A1	10	φ12	-	-	10	-	-	-	-	99.9	
S1.5S 28A - 1210F	28	φ42	φ45	A1	12	φ10	-	-	12	-	-	-	-	123.1	
S1.5S 28A = 1212	28	φ42	φ45	A1	12	φ12	-	-	12	4 × 1.8	-	-	-	119.2	
S1.5S 28A = 1215	28	φ42	φ45	A1	12	φ15	-	-	12	5 × 2.3	-	-	-	112.8	
S1.5S 28A - 1612F	28	φ42	φ45	A1	16	φ12	-	-	16	-	-	-	-	159.8	
S1.5S 28A - 1812F	28	φ42	φ45	A1	18	φ12	-	-	18	-	-	-	-	179.8	
S1.5S 28A = 1815	28	φ42	φ45	A1	18	φ15	-	-	18	5 × 2.3	-	-	-	169.2	
S1.5S 28A = 1820	28	φ42	φ45	A1	18	φ20	-	-	18	6 × 2.8	-	-	-	149.0	
S1.5S 28B - 1010F	28	φ42	φ45	B1	10	φ10	φ36	10	20	-	-	-	-	176.3	
S1.5S 28B - 1210	28	φ42	φ45	B1	12	φ10	φ30	10	22	-	-	-	-	172.5	
S1.5S 28B # 1212	28	φ42	φ45	B1	12	φ12	φ30	10	22	4 × 1.8	M3	5	-	165.0	
S1.5S 28B # 1215	28	φ42	φ45	B1	12	φ15	φ30	10	22	5 × 2.3	M3	5	-	154.1	
S1.5S 28B - 1612	28	φ42	φ45	B1	16	φ12	φ36	10	26	-	-	-	-	231.0	
S1.5S 28B - 1812	28	φ42	φ45	B1	18	φ12	φ36	10	28	-	-	-	-	251.0	
S1.5S 28B # 1815	28	φ42	φ45	B1	18	φ15	φ36	10	28	5 × 2.3	M4	5	-	233.8	
S1.5S 28B # 1818	28	φ42	φ45	B1	18	φ18	φ36	10	28	6 × 2.8	M5	5	-	215.4	
S1.5S 28B # 1820	28	φ42	φ45	B1	18	φ20	φ36	10	28	6 × 2.8	M5	5	-	202.4	
S1.5S 29A - 1210F	29	φ43.5	φ46.5	A1	12	φ10	-	-	12	-	-	-	-	132.6	
S1.5S 29A - 1812F	29	φ43.5	φ46.5	A1	18	φ12	-	-	18	-	-	-	-	194.0	
S1.5S 29B - 1210F	29	φ43.5	φ46.5	B1	12	φ10	φ38	10	22	-	-	-	-	215.5	
S1.5S 29B - 1812	29	φ43.5	φ46.5	B1	18	φ12	φ38	10	28	-	-	-	-	274.3	

【=】(イコール)にはキー材が付いております。【=】: Gear with key way / with key

【#】(シャープ)にはキー材とセットスクリューが付いております。【#】: Gear with key way and threaded hole / with key and screw.

許容伝達動力表 曲げ強さ (kW)

T (N · m)

Allowable transfer capability table (kW) Bending Strength

歯数 z	歯幅 b	回転速度 (min ⁻¹) revolution/min							回転速度 (min ⁻¹) revolution/min
		10	100	200	400	800	1,200	1,500	
28	10	0.028	0.282	0.565	1.130	2.030	2.722	3.224	100
28	12	0.033	0.339	0.678	1.356	2.436	3.267	3.869	100
28	16	0.045	0.452	0.904	1.809	3.248	4.356	5.159	100
28	18	0.050	0.508	1.017	2.035	3.654	4.901	5.804	100
29	12	0.035	0.355	0.711	1.423	2.534	3.389	4.042	100
29	18	0.053	0.533	1.067	2.135	3.802	5.084	6.063	100

KG 規格は“並幅”(軽荷重用)と“広幅”(重荷重用)があります。ご用途に応じてお選び下さい。

KG STOCK GEARS has Wide-face width for Heavy load, and Standard-face width for Light load.

You are able to multiple choices for your suitable design from our wide range.

The above numerical values are equivalent to JGMA formulas as reference only.

動力の換算式は P26 をご参照ください。Please refer to the conversion fomulas of power on page P26.

目次

インフォメーション

ギヤボックス

ノーバッキングギヤ

歯研削歯車

平歯車

内歯車

歯ラック

ラック

メカニカルギヤ

ワーム

かさ歯車

スプロケット

技術資料

平歯車

SPUR GEARS

モジュール **1.5** 圧力角 20° (並歯) 歯数 30
 MODULE 20° PRESSURE ANGLE FULL DEPTH TOOTH Z30

JIS B 1702-1 (ISO) 8級 (高周波焼入品: 9級)
 System of accuracy: JIS B 1702-1(ISO) class 8
 (Induction hardened products: class 9)



New 仕様変更 省スペース・軽量化、締結加工不要。
 Specification change Space-saving and weight saving.
 Additional machining on tightening is not necessary.

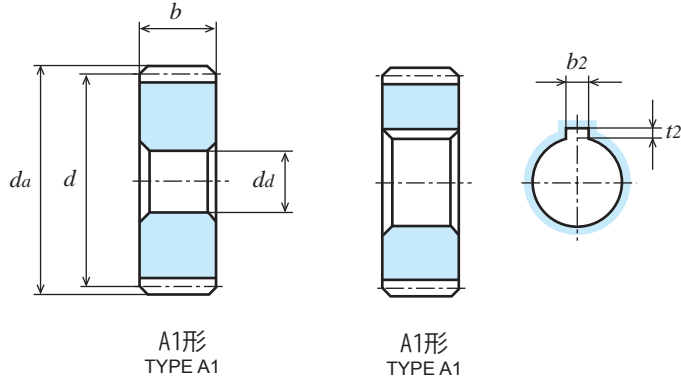

S45C 機械構造用炭素鋼 (JIS G 4051)

Material: Carbon Steel (ISO C45)

単位: mm
 Dimensions: mm

商品記号 Catalogue Number	歯数 Number of Teeth z	基準円直径 Reference Diameter d	歯先円直径 Outside Diameter da	形 Type	歯幅 Face Width b	穴径 Bore Diameter da(H7)	ハブ外径 Hub Diameter dh	ハブ長さ Hub Projection lh	全長 Overall Length l	キミぞ Key Way b2 × t2	ねじ Set Screw		リム内径 Dimension of Rim di	ウェブ厚さ Thickness of Web bw	重量 Weight W(g)
											M	ls			
S1.5S 30A - 1012F	30	φ45	φ48	A1	10	φ12	-	-	10	-	-	-	-	116.0	
S1.5S 30A - 1210F	30	φ45	φ48	A1	12	φ10	-	-	12	-	-	-	-	142.4	
S1.5S 30A = 1212	30	φ45	φ48	A1	12	φ12	-	-	12	4 × 1.8	-	-	-	138.5	
S1.5S 30A = 1215	30	φ45	φ48	A1	12	φ15	-	-	12	5 × 2.3	-	-	-	132.1	
S1.5S 30A - 1614F	30	φ45	φ48	A1	16	φ14	-	-	16	-	-	-	-	180.4	
S1.5S 30A - 1814F	30	φ45	φ48	A1	18	φ14	-	-	18	-	-	-	-	203.0	
S1.5S 30A = 1815	30	φ45	φ48	A1	18	φ15	-	-	18	5 × 2.3	-	-	-	198.1	
S1.5S 30A = 1818	30	φ45	φ48	A1	18	φ18	-	-	18	6 × 2.8	-	-	-	186.4	
S1.5S 30A = 1820	30	φ45	φ48	A1	18	φ20	-	-	18	6 × 2.8	-	-	-	178.0	
S1.5S 30B - 1010F	30	φ45	φ48	B1	10	φ10	φ38	10	20	-	-	-	-	201.5	
S1.5S 30B - 1210	30	φ45	φ48	B1	12	φ10	φ30	10	22	-	-	-	-	191.9	
S1.5S 30B # 1212	30	φ45	φ48	B1	12	φ12	φ30	10	22	4 × 1.8	M3	5	-	184.3	
S1.5S 30B # 1215	30	φ45	φ48	B1	12	φ15	φ30	10	22	5 × 2.3	M4	5	-	172.5	
S1.5S 30BF - 1508	30	φ45	φ48	B1	15	φ8(H8)	φ38	15	30	-	-	-	-	307.3	
S1.5S 30B - 1508H	30	φ45	φ48	B1	15	φ8(H※)	φ38	15	30	-	-	-	-	307.3	
S1.5S 30B - 1612	30	φ45	φ48	B1	16	φ12	φ38	10	26	-	-	-	-	265.9	
S1.5S 30B - 1812	30	φ45	φ48	B1	18	φ12	φ40	10	28	-	-	-	-	298.7	
S1.5S 30B # 1815	30	φ45	φ48	B1	18	φ15	φ40	10	28	5 × 2.3	M4	5	-	281.4	
S1.5S 30B # 1818	30	φ45	φ48	B1	18	φ18	φ40	10	28	6 × 2.8	M5	5	-	262.9	
S1.5S 30B # 1820	30	φ45	φ48	B1	18	φ20	φ40	10	28	6 × 2.8	M5	5	-	249.9	

●の商品は新商品です。Products with ● marks are new item.

【=】(イコール)にはキー材が付いております。 [=]: Gear with key way / with key

【#】(シャープ)にはキー材とセットスクリューが付いております。 [#]: Gear with key way and threaded hole / with key and screw.

カタログ記号の末尾に【H】を付した商品は歯部高周波焼入済です。 Gear tooth surface completed with induction hardening, Hardness HRC47 to 53.
 ※

歯部高周波焼入後の穴修正は行っていません。 Bore correcting after induction hardening is not completed.

追加加工の際は、追加加工時の注意をご参照ください。 Please refer to Precaution for additional process when additional process.

許容伝達動力表 曲げ強さ (kW)

Allowable transfer capability table (kW) Bending Strength

歯数 z	歯幅 b	焼入 H	回転速度 (min ⁻¹) revolution/min						
			10	100	200	400	800	1,200	1,500
30	10	-	0.031	0.310	0.620	1.241	2.192	2.923	3.509
30	12	-	0.037	0.372	0.744	1.489	2.630	3.508	4.211
30	15	-	0.047	0.470	0.930	1.860	3.290	4.390	5.270
30	15	○	0.049	0.494	0.988	1.976	3.527	4.747	5.714
30	16	-	0.049	0.496	0.993	1.986	3.507	4.677	5.615
30	18	-	0.055	0.558	1.117	2.234	3.946	5.262	6.317

The above references are JGMA standard.

動力の換算式は P26 をご参照ください。 Please refer to the conversion formulas of power on page P26.

許容伝達動力表 歯面強さ (kW)

Allowable transfer capability table (kW) Surface Durability

回転速度 (min ⁻¹) revolution/min						
10	100	200	400	800	1,200	1,500
-	-	-	-	-	-	-
-	-	-	-	-	-	-
0.003	0.030	0.050	0.110	0.200	0.270	0.330
0.012	0.132	0.272	0.560	1.030	1.411	1.715
-	-	-	-	-	-	-
-	-	-	-	-	-	-

平歯車

SPUR GEARS

モジュール **1.5** 圧力角 20° (並歯) 歯数 32
 MODULE 20° PRESSURE ANGLE FULL DEPTH TOOTH Z32

JIS B 1702-1 (ISO) 8級
 System of accuracy: JIS B 1702-1(ISO) class 8



御注文には必ず“フルネームで商品記号”を明記してください。
 Please refer to the catalogue reference while ordering.

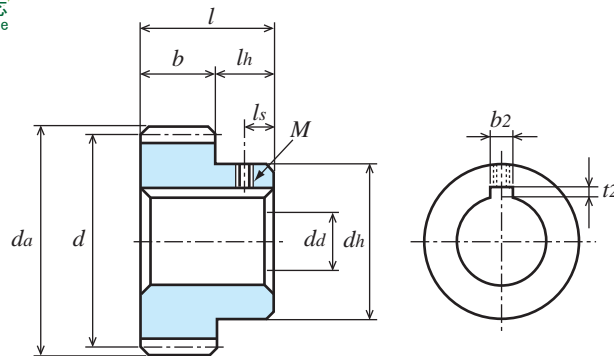

B1形
TYPE B1

S45C 機械構造用炭素鋼 (JIS G 4051) Material: Carbon Steel (ISO C45)

単位: mm
 Dimensions: mm

商品記号 Catalogue Number	歯数 Number of Teeth z	基準円直径 Reference Diameter d	歯先円直径 Outside Diameter da	形 Type	歯幅 Face Width b	穴径 Bore Diameter da(H7)	ハブ外径 Hub Diameter dh	ハブ長さ Hub Projection lh	全長 Overall Length l	キ み ぞ Key Way b2 × t2	ねじ Set Screw		リム内径 Dimension of Rim di	ウェブ厚さ Thickness of Web bw	重量 Weight W(g)
											M	ls			
S1.5S 32A - 1010F	32	φ48	φ51	A1	10	φ10	-	-	10	-	-	-	-	135.9	
S1.5S 32A = 1012	32	φ48	φ51	A1	10	φ12	-	-	10	4 × 1.8	-	-	-	132.6	
S1.5S 32A = 1015	32	φ48	φ51	A1	10	φ15	-	-	10	5 × 2.3	-	-	-	127.3	
S1.5S 32A - 1614F	32	φ48	φ51	A1	16	φ14	-	-	16	-	-	-	-	207.9	
S1.5S 32A = 1615	32	φ48	φ51	A1	16	φ15	-	-	16	5 × 2.3	-	-	-	203.6	
S1.5S 32A = 1618	32	φ48	φ51	A1	16	φ18	-	-	16	6 × 2.8	-	-	-	193.2	
S1.5S 32A = 1620	32	φ48	φ51	A1	16	φ20	-	-	16	6 × 2.8	-	-	-	185.7	
S1.5S 32B - 1010	32	φ48	φ51	B1	10	φ10	φ30	10	20	-	-	-	-	185.3	
S1.5S 32B # 1012	32	φ48	φ51	B1	10	φ12	φ30	10	20	4 × 1.8	M3	5	-	178.4	
S1.5S 32B # 1015	32	φ48	φ51	B1	10	φ15	φ30	10	20	5 × 2.3	M4	5	-	167.7	
S1.5S 32B - 1612	32	φ48	φ51	B1	16	φ12	φ40	10	26	-	-	-	-	303.0	
S1.5S 32B # 1615	32	φ48	φ51	B1	16	φ15	φ40	10	26	5 × 2.3	M4	5	-	286.9	
S1.5S 32B # 1618	32	φ48	φ51	B1	16	φ18	φ40	10	26	6 × 2.8	M5	5	-	269.7	
S1.5S 32B # 1620	32	φ48	φ51	B1	16	φ20	φ40	10	26	6 × 2.8	M5	5	-	257.6	

【=】 (イコール) にはキー材が付いております。 [=]: Gear with key way / with key

【#】 (シャープ) にはキー材とセットスクリューが付いております。 [#]: Gear with key way and threaded hole / with key and screw.

許容伝達動力表 曲げ強さ (kW)

Allowable transfer capability table (kW) Bending Strength

歯数 z	歯幅 b	回転速度 (min ⁻¹) revolution/min							回転速度 (min ⁻¹) revolution/min
		10	100	200	400	800	1,200	1,500	100
32	10	0.033	0.338	0.677	1.352	2.351	3.122	3.793	32.27
32	16	0.054	0.541	1.083	2.164	3.762	4.996	6.069	51.66

KG規格は“並幅”(軽荷重用)と“広幅”(重荷重用)があります。ご用途に応じてお選び下さい。

KG STOCK GEARS has Wide-face width for Heavy load, and Standard-face width for Light load.

You are able to multiple choices for your suitable design from our wide range.

The above numerical values are equivalent to JGMA formulas as reference only.

動力の換算式は P26 をご参照ください。Please refer to the conversion formulas of power on page P26.

平歯車 SPUR GEARS

モジュール **1.5** 圧力角 20° (並歯) 歯数 34 35
 MODULE 20° PRESSURE ANGLE FULL DEPTH TOOTH Z 34 to Z 35

JIS B 1702-1 (ISO) 8級
 System of accuracy : JIS B 1702-1(ISO) class 8



New 仕様変更 省スペース・軽量化。
 Specification change Space-saving and weight saving.

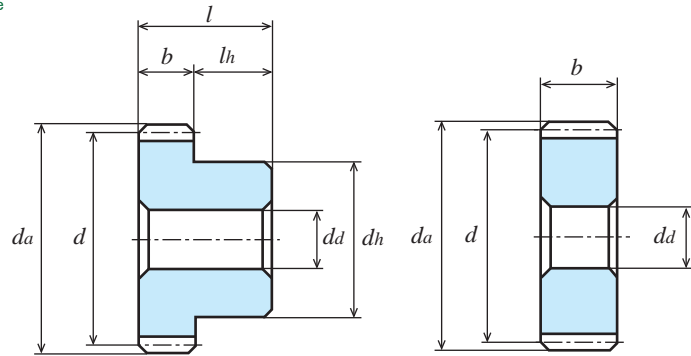

R1形

A1形

S45C 機械構造用炭素鋼 (JIS G 4051) Material : Carbon Steel (ISO C45)

単位 : mm
 Dimensions : mm

商品記号 Catalogue Number	歯数 Number of Teeth z	基準円直径 Reference Diameter d	歯先円直径 Tip Diameter da	形 Type	歯幅 Face Width b	穴径 Bore Diameter da(H7)	ハブ外径 Hub Diameter dh	ハブ長さ Hub Projection lh	全長 Overall Length l	キーみぞ Key Way b ₂ × t ₂	重量 Weight W(g)
S1.5S 34A - 1012F	34	φ51	φ54	A1	10	φ12	-	-	10	-	151.5
S1.5S 34A - 1614F	34	φ51	φ54	A1	16	φ14	-	-	16	-	237.2
S1.5S 34B - 1010F	34	φ51	φ54	B1	10	φ10	φ44	10	20	-	267.4
S1.5S 34B - 1612	34	φ51	φ54	B1	16	φ12	φ44	10	26	-	353.1
S1.5S 35A - 1012F	35	φ52.5	φ55.5	A1	10	φ12	-	-	10	-	161.1
S1.5S 35A - 1614F	35	φ52.5	φ55.5	A1	16	φ14	-	-	16	-	252.6
S1.5S 35B - 1010F	35	φ52.5	φ55.5	B1	10	φ10	φ44	10	20	-	277.0
S1.5S 35B - 1612	35	φ52.5	φ55.5	B1	16	φ12	φ44	10	26	-	368.4

許容伝達動力表 曲げ強さ (kW)

T (N · m)

Allowable transfer capability table (kW) Bending Strength

歯数 z	歯幅 b	回転速度 (min ⁻¹) revolution/min							回転速度 (min ⁻¹) revolution/min
		10	100	200	400	800	1,200	1,500	
34	10	0.036	0.366	0.733	1.452	2.507	3.359	4.074	34.95
34	16	0.058	0.586	1.173	2.323	4.011	5.375	6.519	55.96
35	10	0.038	0.381	0.762	1.501	2.583	3.477	4.214	36.38
35	16	0.060	0.609	1.219	2.402	4.133	5.563	6.743	58.15

The above numerical values are equivalent to JGMA formulas as reference only.

動力の換算式は P26 をご参照ください。Please refer to the conversion fomulas of power on page P26.

平歯車

SPUR GEARS

モジュール
MODULE

1.5

圧力角 20° (並歯)

歯数 36 38

20° PRESSURE ANGLE FULL DEPTH TOOTH Z36 to Z38

JIS B 1702-1 (ISO) 8級
System of accuracy : JIS B 1702-1(ISO) class 8



御注文には必ず“フルネームで商品記号”を明記してください。
Please refer to the catalogue reference while ordering.

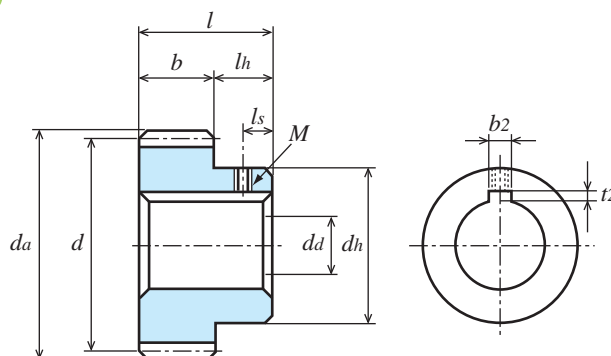

B1形
TYPE B1

S45C 機械構造用炭素鋼 (JIS G 4051)

Material : Carbon Steel (ISO C45)

単位 : mm
Dimensions : mm

商品記号 Catalogue Number	歯数 Number of Teeth z	基準円直径 Reference Diameter d	歯先円直径 Outside Diameter da	形 Type	歯幅 Face Width b	穴径 Bore Diameter da(H7)	ハブ外径 Hub Diameter dh	ハブ長さ Hub Projection lh	全長 Overall Length l	キミぞ Key Way b2 × t2	ねじ Set Screw		リム内径 Dimension of Rim di	ウエブ厚さ Thickness of Web bw	重量 Weight W(g)
											M	ls			
S1.5S 36A - 1012F	36	φ54	φ57	A1	10	φ12	-	-	10	-	-	-	-	170.9	
S1.5S 36A = 1015	36	φ54	φ57	A1	10	φ15	-	-	10	5 × 2.3	-	-	-	165.0	
S1.5S 36A = 1016	36	φ54	φ57	A1	10	φ16	-	-	10	5 × 2.3	-	-	-	163.1	
S1.5S 36A - 1614F	36	φ54	φ57	A1	16	φ14	-	-	16	-	-	-	-	268.3	
S1.5S 36A = 1615	36	φ54	φ57	A1	16	φ15	-	-	16	5 × 2.3	-	-	-	264.0	
S1.5S 36A = 1618	36	φ54	φ57	A1	16	φ18	-	-	16	6 × 2.8	-	-	-	253.6	
S1.5S 36A = 1620	36	φ54	φ57	A1	16	φ20	-	-	16	6 × 2.8	-	-	-	246.1	
S1.5S 36B - 1010	36	φ54	φ57	B1	10	φ10	φ32	10	20	-	-	-	-	230.7	
S1.5S 36B # 1012	36	φ54	φ57	B1	10	φ12	φ32	10	20	4 × 1.8	M3	5	-	223.8	
S1.5S 36B # 1015	36	φ54	φ57	B1	10	φ15	φ32	10	20	5 × 2.3	M4	5	-	213.0	
S1.5S 36B # 1016	36	φ54	φ57	B1	10	φ16	φ32	10	20	5 × 2.3	M4	5	-	209.2	
S1.5S 36B - 1612	36	φ54	φ57	B1	16	φ12	φ40	10	26	-	-	-	-	363.5	
S1.5S 36B # 1615	36	φ54	φ57	B1	16	φ15	φ40	10	26	5 × 2.3	M4	5	-	347.3	
S1.5S 36B # 1618	36	φ54	φ57	B1	16	φ18	φ40	10	26	6 × 2.8	M5	5	-	330.1	
S1.5S 36B # 1620	36	φ54	φ57	B1	16	φ20	φ40	10	26	6 × 2.8	M5	5	-	318.0	
S1.5S 38A - 1012F	38	φ57	φ60	A1	10	φ12	-	-	10	-	-	-	-	191.4	
S1.5S 38A - 1614F	38	φ57	φ60	A1	16	φ14	-	-	16	-	-	-	-	301.2	
S1.5S 38B - 1012F	38	φ57	φ60	B1	10	φ12	φ50	10	20	-	-	-	-	336.7	
S1.5S 38B - 1612	38	φ57	φ60	B1	16	φ12	φ50	10	26	-	-	-	-	451.8	

【=】(イコール)にはキー材が付いております。【#】: Gear with key way / with key
【#】(シャープ)にはキー材とセットスクリューが付いております。【#】: Gear with key way and threaded hole / with key and screw.

許容伝達動力表 曲げ強さ (kW)

Allowable transfer capability table (kW) Bending Strength

歯数 z	歯幅 b	回転速度 (min ⁻¹) revolution/min							回転速度 (min ⁻¹) revolution/min
		10	100	200	400	800	1,200	1,500	
36	10	0.039	0.395	0.790	1.550	2.659	3.594	4.353	100
36	16	0.063	0.632	1.265	2.481	4.254	5.751	6.966	60.35
38	10	0.042	0.424	0.848	1.648	2.807	3.828	4.629	40.49
38	16	0.067	0.678	1.356	2.637	4.492	6.125	7.407	64.74

KG規格は“並幅”(軽荷重用)と“広幅”(重荷重用)があります。ご用途に応じてお選び下さい。

KG STOCK GEARS has Wide-face width for Heavy load, and Standard-face width for Light load.

You are able to multiple choices for your suitable design from our wide range.

The above numerical values are equivalent to JGMA formulas as reference only.

動力の換算式はP26をご参照ください。Please refer to the conversion fomulas of power on page P26.

目次
CONTENTS

インフォメーション
INFORMATION

ギヤボックス
GEAR BOXES

ノーバッキングギヤ
ANTI BACKLASH SPUR GEARS

歯研削歯車
GROUND SPUR GEARS

歯研削歯車
SPUR GEARS

内歯車
INTERNAL GEARS

歯研削ラック
GROUND RACKS

ラック
RACKS

ハニカム・スクリューギヤ
HELICAL GEARS AND SCREW GEARS

ウォーム・ウォームギヤ
WORMS AND WORM GEARS

かさ歯車
BEVEL GEARS

スプロケット
SPROCKETS

技術仕様書
REFERENCE DATA

平歯車

SPUR GEARS

モジュール **1.5** 圧力角 20° (並歯) 歯数 40
 MODULE 20° PRESSURE ANGLE FULL DEPTH TOOTH Z 40

JIS B 1702-1 (ISO) 8級 (高周波焼入品: 9級)
 System of accuracy: JIS B 1702-1(ISO) class 8
 (Induction hardened products: class 9)



New 仕様変更 省スペース・軽量化、締結加工不要。
 Specification change Space-saving and weight saving.
 Additional machining on tightening is not necessary.

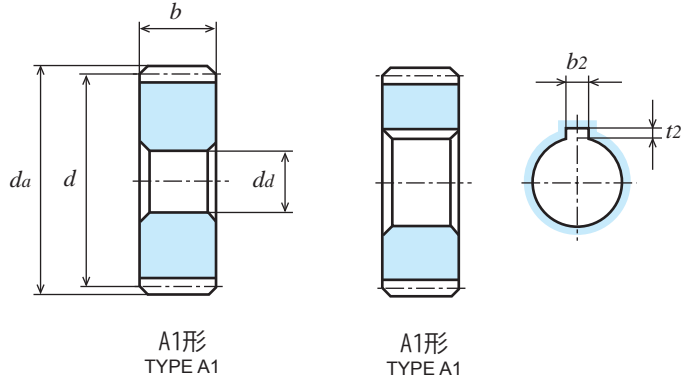

S45C 機械構造用炭素鋼 (JIS G 4051)

Material: Carbon Steel (ISO C45)

単位: mm
 Dimensions: mm

商品記号 Catalogue Number	歯数 Number of Teeth z	基準円直径 Reference Diameter d	歯先円直径 Outside Diameter da	形 Type	歯幅 Face Width b	穴径 Bore Diameter da(H7)	ハブ外径 Hub Diameter dh	ハブ長さ Hub Projection lh	全長 Overall Length l	キミぞ Key Way b2 × t2	ねじ Set Screw		リム内径 Dimension of Rim di	ウェブ厚さ Thickness of Web bw	重量 Weight W(g)
											M	ls			
S1.5S 40A - 1012F	40	φ60	φ63	A1	10	φ12	-	-	10	-	-	-	-	213.1	
S1.5S 40A = 1015	40	φ60	φ63	A1	10	φ15	-	-	10	5 × 2.3	-	-	-	207.2	
S1.5S 40A = 1016	40	φ60	φ63	A1	10	φ16	-	-	10	5 × 2.3	-	-	-	205.3	
S1.5S 40A = 1018	40	φ60	φ63	A1	10	φ18	-	-	10	6 × 2.8	-	-	-	200.7	
S1.5S 40A - 1614F	40	φ60	φ63	A1	16	φ14	-	-	16	-	-	-	-	335.8	
S1.5S 40A = 1615	40	φ60	φ63	A1	16	φ15	-	-	16	5 × 2.3	-	-	-	331.5	
S1.5S 40A = 1618	40	φ60	φ63	A1	16	φ18	-	-	16	6 × 2.8	-	-	-	321.1	
S1.5S 40A = 1620	40	φ60	φ63	A1	16	φ20	-	-	16	6 × 2.8	-	-	-	313.6	
S1.5S 40B - 1012	40	φ60	φ63	B1	10	φ12	φ36	10	20	-	-	-	-	284.3	
S1.5S 40B # 1015	40	φ60	φ63	B1	10	φ15	φ36	10	20	5 × 2.3	M4	5	-	271.8	
S1.5S 40B # 1016	40	φ60	φ63	B1	10	φ16	φ36	10	20	5 × 2.3	M4	5	-	268.0	
S1.5S 40B # 1018	40	φ60	φ63	B1	10	φ18	φ36	10	20	6 × 2.8	M5	5	-	258.6	
S1.5S 40BF - 1508	40	φ60	φ63	B1	15	φ 8(H8)	φ50	15	30	-	-	-	-	550.2	
S1.5S 40B - 1508H	40	φ60	φ63	B1	15	φ 8(H※)	φ50	15	30	-	-	-	-	550.2	
S1.5S 40B - 1612	40	φ60	φ63	B1	16	φ12	φ40	10	26	-	-	-	-	431.0	
S1.5S 40B # 1615	40	φ60	φ63	B1	16	φ15	φ40	10	26	5 × 2.3	M4	5	-	414.8	
S1.5S 40B # 1618	40	φ60	φ63	B1	16	φ18	φ40	10	26	6 × 2.8	M5	5	-	397.6	
S1.5S 40B # 1620	40	φ60	φ63	B1	16	φ20	φ40	10	26	6 × 2.8	M5	5	-	385.6	

●の商品は新商品です。Products with ● marks are new item.

【=】(イコール)にはキー材が付いております。 [=]: Gear with key way / with key

【#】(シャープ)にはキー材とセットスクリューが付いております。 [#]: Gear with key way and threaded hole / with key and screw.

カタログ記号の末尾に【H】を付した商品は歯部高周波焼入済です。 Gear tooth surface completed with induction hardening, Hardness HRC47 to 53.

※
 歯部高周波焼入後の穴修正は行っていません。 Bore correcting after induction hardening is not completed.

追加加工の際は、追加加工時の注意をご参照ください。 Please refer to Precaution for additional process when additional process.

許容伝達動力表 曲げ強さ (kW)

Allowable transfer capability table (kW) Bending Strength

歯数 z	歯幅 b	焼入 H	回転速度 (min ⁻¹) revolution/min						
			10	100	200	400	800	1,200	1,500
40	10	-	0.045	0.452	0.905	1.744	2.952	4.060	4.902
40	15	-	0.068	0.680	1.360	2.610	4.420	6.080	7.340
40	15	○	0.072	0.719	1.437	2.777	4.766	6.594	7.982
40	16	-	0.072	0.724	1.449	2.791	4.724	6.496	7.844

The above references are JGMA standard.

動力の換算式は P26 をご参照ください。 Please refer to the conversion formulas of power on page P26.

許容伝達動力表 歯面強さ (kW)

Allowable transfer capability table (kW) Surface Durability

回転速度 (min ⁻¹) revolution/min						
10	100	200	400	800	1,200	1,500
-	-	-	-	-	-	-
0.005	0.050	0.100	0.190	0.340	0.480	0.590
0.022	0.241	0.496	0.988	1.748	2.462	3.009
-	-	-	-	-	-	-

平歯車

SPUR GEARS

モジュール
MODULE

1.5

圧力角 20° (並歯)

歯数 42 ~ 46

20° PRESSURE ANGLE FULL DEPTH TOOTH Z 42 to Z 46

JIS B 1702-1 (ISO) 8 級
System of accuracy : JIS B 1702-1(ISO) class 8



御注文には必ず“フルネームで商品記号”を明記してください。

Please refer to the catalogue reference while ordering.

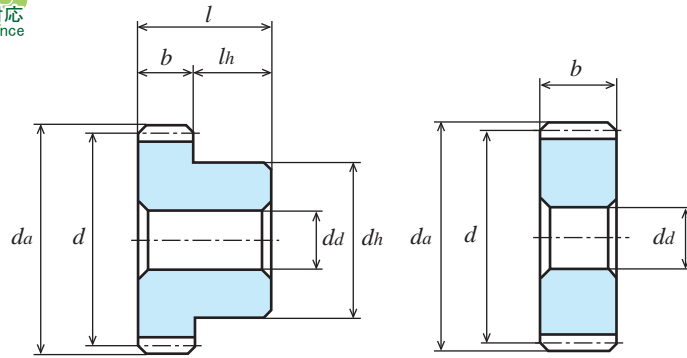

B1形
TYPE B1

A1形
TYPE A1

S45C 機械構造用炭素鋼 (JIS G 4051)

Material : Carbon Steel (ISO C45)

単位 : mm
Dimensions : mm

商品記号 Catalogue Number	歯数 Number of Teeth z	基準円直径 Reference Diameter d	歯先円直径 Tip Diameter da	形 Type	歯幅 Face Width b	穴径 Bore Diameter da(H7)	ハブ外径 Hub Diameter dh	ハブ長さ Hub Projection lh	全長 Overall Length l	キミぞ Key Way b ₂ × t ₂	重量 Weight W(g)
S1.5S 42A - 1012F	42	φ63	φ66	A1	10	φ12	-	-	10	-	235.8
S1.5S 42A - 1612F	42	φ63	φ66	A1	16	φ12	-	-	16	-	377.3
S1.5S 42B - 1012F	42	φ63	φ66	B1	10	φ12	φ50	10	20	-	381.1
S1.5S 42B - 1612	42	φ63	φ66	B1	16	φ12	φ50	10	26	-	522.9
S1.5S 44A - 1012F	44	φ66	φ69	A1	10	φ12	-	-	10	-	259.7
S1.5S 44A - 1612F	44	φ66	φ69	A1	16	φ12	-	-	16	-	415.5
S1.5S 44B - 1012F	44	φ66	φ69	B1	10	φ12	φ50	10	20	-	404.9
S1.5S 44B - 1612	44	φ66	φ69	B1	16	φ12	φ50	10	26	-	561.1
S1.5S 45A - 1012F	45	φ67.5	φ70.5	A1	10	φ12	-	-	10	-	272.0
S1.5S 45A - 1612F	45	φ67.5	φ70.5	A1	16	φ12	-	-	16	-	435.3
S1.5S 45B - 1012F	45	φ67.5	φ70.5	B1	10	φ12	φ50	10	20	-	417.3
S1.5S 45B - 1612	45	φ67.5	φ70.5	B1	16	φ12	φ50	10	26	-	580.9
S1.5S 46A - 1012F	46	φ69	φ72	A1	10	φ12	-	-	10	-	284.7
S1.5S 46A - 1612F	46	φ69	φ72	A1	16	φ12	-	-	16	-	455.4
S1.5S 46B - 1012F	46	φ69	φ72	B1	10	φ12	φ50	10	20	-	429.9
S1.5S 46B - 1612	46	φ69	φ72	B1	16	φ12	φ50	10	26	-	601.1

許容伝達動力表 曲げ強さ (kW)

T (N · m)

Allowable transfer capability table (kW) Bending Strength

歯数 z	歯幅 b	回転速度 (min ⁻¹) revolution/min							回転速度 (min ⁻¹) revolution/min
		10	100	200	400	800	1,200	1,500	
42	10	0.048	0.481	0.963	1.839	3.094	4.290	5.173	45.93
42	16	0.077	0.771	1.542	2.943	4.951	6.864	8.276	73.62
44	10	0.051	0.510	1.021	1.932	3.230	4.515	5.448	48.70
44	16	0.080	0.820	1.630	3.090	5.170	7.220	8.720	78.30
45	10	0.052	0.525	1.050	1.978	3.298	4.628	5.588	50.13
45	16	0.080	0.840	1.680	3.170	5.280	7.410	8.940	80.21
46	10	0.053	0.539	1.079	2.024	3.365	4.740	5.727	51.47
46	16	0.090	0.860	1.730	3.240	5.380	7.580	9.160	82.12

KG 規格は“並幅” (軽荷重用) と“広幅” (重荷重用) があります。ご用途に応じてお選び下さい。

KG STOCK GEARS has Wide-face width for Heavy load, and Standard-face width for Light load.

You are able to multiple choices for your suitable design from our wide range.

The above numerical values are equivalent to JGMA formulas as reference only.

動力の換算式は P26 をご参照ください。Please refer to the conversion fomulas of power on page P26.

目次
CONTENTS

インフォメーション
INFORMATION

ギヤボックス
GEAR BOXES

ノーバッキングギヤ
ANTI BACKLASH SPUR GEARS

歯研削歯車
GROUND SPUR GEARS

平歯車
SPUR GEARS

内歯車
INTERNAL GEARS

歯研削歯車
GROUND RACKS

ラック
RACKS

ハニカムギヤ
HELIICAL GEARS AND SCREW GEARS

ワーム
WORMS AND WORM WHEELS

かさ歯車
BEVEL GEARS

スプロケット
SPROCKETS

技術仕様
REFERENCE DATA

平歯車 SPUR GEARS

モジュール **1.5** 圧力角 20° (並歯) 歯数 48
 MODULE 20° PRESSURE ANGLE FULL DEPTH TOOTH Z 48

JIS B 1702-1 (ISO) 8級
 System of accuracy : JIS B 1702-1(ISO) class 8



New 仕様変更 省スペース・軽量化、締結加工不要。
 Specification change Space-saving and weight saving.
 Additional machining on tightening is not necessary.

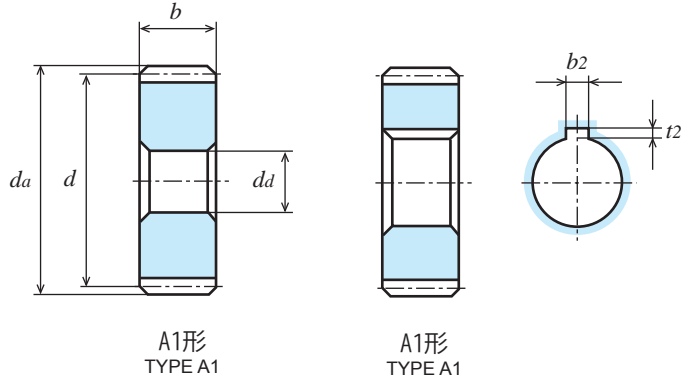

S45C 機械構造用炭素鋼 (JIS G 4051) Material : Carbon Steel (ISO C45)

単位 : mm
 Dimensions : mm

商品記号 Catalogue Number	歯数 Number of Teeth <i>z</i>	基準円直径 Reference Diameter <i>d</i>	歯先円直径 Outside Diameter <i>da</i>	形 Type	歯幅 Face Width <i>b</i>	穴径 Bore Diameter <i>da</i> (H7)	ハブ外径 Hub Diameter <i>dh</i>	ハブ長さ Hub Projection <i>lh</i>	全長 Overall Length <i>l</i>	キーマイぞ Key Way <i>b2 × t2</i>	ねじ Set Screw		リム内径 Dimension of Rim <i>di</i>	ウェブ厚さ Thickness of Web <i>bw</i>	重量 Weight <i>W</i> (g)
											<i>M</i>	<i>ls</i>			
S1.5S 48A - 1014F	48	φ72	φ75	A1	10	φ14	-	-	10	-	-	-	-	307.5	
S1.5S 48A = 1015	48	φ72	φ75	A1	10	φ15	-	-	10	5 × 2.3	-	-	-	304.8	
S1.5S 48A = 1016	48	φ72	φ75	A1	10	φ16	-	-	10	5 × 2.3	-	-	-	302.9	
S1.5S 48A = 1018	48	φ72	φ75	A1	10	φ18	-	-	10	6 × 2.8	-	-	-	298.3	
S1.5S 48A - 1616F	48	φ72	φ75	A1	16	φ16	-	-	16	-	-	-	-	486.1	
S1.5S 48A = 1620	48	φ72	φ75	A1	16	φ20	-	-	16	6 × 2.8	-	-	-	469.8	
S1.5S 48B - 1012	48	φ72	φ75	B1	10	φ12	φ36	10	20	-	-	-	-	382.0	
S1.5S 48B # 1015	48	φ72	φ75	B1	10	φ15	φ36	10	20	5 × 2.3	M4	5	-	369.5	
S1.5S 48B # 1016	48	φ72	φ75	B1	10	φ16	φ36	10	20	5 × 2.3	M4	5	-	365.8	
S1.5S 48B # 1018	48	φ72	φ75	B1	10	φ18	φ36	10	20	6 × 2.8	M5	5	-	356.4	
S1.5S 48B - 1612	48	φ72	φ75	B1	16	φ12	φ40	10	26	-	-	-	-	587.3	
S1.5S 48B # 1615	48	φ72	φ75	B1	16	φ15	φ40	10	26	5 × 2.3	M4	5	-	571.1	
S1.5S 48B # 1620	48	φ72	φ75	B1	16	φ20	φ40	10	26	6 × 2.8	M5	5	-	541.9	

[=] (イコール) にはキー材が付いております。[=]: Gear with key way / with key
 [#] (シャープ) にはキー材とセットスクリューが付いております。[#]: Gear with key way and threaded hole / with key and screw.

許容伝達動力表 曲げ強さ (kW)

Allowable transfer capability table (kW) Bending Strength

歯数 <i>z</i>	歯幅 <i>b</i>	回転速度 (min ⁻¹) revolution/min							回転速度 (min ⁻¹) revolution/min
		10	100	200	400	800	1,200	1,500	
48	10	0.05	0.56	1.13	2.11	3.50	4.96	6.00	100
48	16	0.09	0.91	1.82	3.39	5.60	7.94	9.61	86.90

The above numerical values are equivalent to JGMA formulas as reference only.
 動力の換算式は P26 をご参照ください。Please refer to the conversion fomulas of power on page P26.

平歯車

SPUR GEARS

モジュール **1.5** 圧力角 20° (並歯) 歯数 50
 MODULE 20° PRESSURE ANGLE FULL DEPTH TOOTH Z 50

JIS B 1702-1 (ISO) 8級 (高周波焼入品: 9級)
 System of accuracy: JIS B 1702-1(ISO) class 8
 (Induction hardened products: class 9)



御注文には必ず“フルネームで商品記号”を明記してください。
 Please refer to the catalogue reference while ordering.

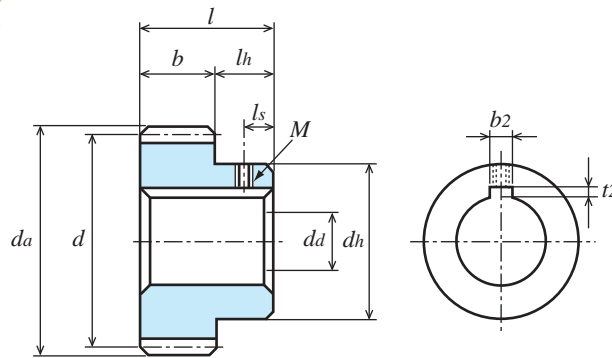

B1形
TYPE B1

S45C 機械構造用炭素鋼 (JIS G 4051) Material: Carbon Steel (ISO C45)

単位: mm
 Dimensions: mm

商品記号 Catalogue Number	歯数 Number of Teeth z	基準円直径 Reference Diameter d	歯先円直径 Outside Diameter da	形 Type	歯幅 Face Width b	穴径 Bore Diameter da(H7)	ハブ外径 Hub Diameter dh	ハブ長さ Hub Projection lh	全長 Overall Length l	キミぞ Key Way b2 × t2	ねじ Set Screw		リム内径 Dimension of Rim di	ウェブ厚さ Thickness of Web bw	重量 Weight W(g)
											M	ls			
S1.5S 50A - 1014F	50	φ75	φ78	A1	10	φ14	-	-	10	-	-	-	-	334.7	
S1.5S 50A = 1015	50	φ75	φ78	A1	10	φ15	-	-	10	5 × 2.3	-	-	-	332.0	
S1.5S 50A = 1018	50	φ75	φ78	A1	10	φ18	-	-	10	6 × 2.8	-	-	-	325.5	
S1.5S 50A = 1020	50	φ75	φ78	A1	10	φ20	-	-	10	6 × 2.8	-	-	-	320.8	
S1.5S 50A - 1616F	50	φ75	φ78	A1	16	φ16	-	-	16	-	-	-	-	529.6	
S1.5S 50A = 1620	50	φ75	φ78	A1	16	φ20	-	-	16	6 × 2.8	-	-	-	513.3	
S1.5S 50A = 1625	50	φ75	φ78	A1	16	φ25	-	-	16	8 × 3.3	-	-	-	489.9	
S1.5S 50B - 1012	50	φ75	φ78	B1	10	φ12	φ40	10	20	-	-	-	-	428.0	
S1.5S 50B # 1015	50	φ75	φ78	B1	10	φ15	φ40	10	20	5 × 2.3	M4	5	-	415.3	
S1.5S 50B # 1018	50	φ75	φ78	B1	10	φ18	φ40	10	20	6 × 2.8	M5	5	-	402.1	
S1.5S 50B # 1020	50	φ75	φ78	B1	10	φ20	φ40	10	20	6 × 2.8	M5	5	-	392.8	
● S1.5S 50BF - 1510	50	φ75	φ78	B1	15	φ10(H8)	φ60	15	30	-	-	-	-	832.2	
● S1.5S 50B - 1510H	50	φ75	φ78	B1	15	φ10(H※)	φ60	15	30	-	-	-	-	832.2	
S1.5S 50B - 1615	50	φ75	φ78	B1	16	φ15	φ50	10	26	-	-	-	-	673.4	
S1.5S 50B # 1620	50	φ75	φ78	B1	16	φ20	φ50	10	26	6 × 2.8	M5	5	-	640.3	
S1.5S 50B # 1625	50	φ75	φ78	B1	16	φ25	φ50	10	26	8 × 3.3	M6	5	-	602.1	

●の商品は新商品です。Products with ● marks are new item.

【=】(イコール)にはキー材が付いております。 [=]: Gear with key way / with key

【#】(シャープ)にはキー材とセットスクリューが付いております。 [#]: Gear with key way and threaded hole / with key and screw.

カタログ記号の末尾に【H】を付した商品は歯部高周波焼入済です。Gear tooth surface completed with induction hardening, Hardness HRC47 to 53.

※
 歯部高周波焼入後の穴修正は行っていません。Bore correcting after induction hardening is not completed.

追加加工の際は、追加加工時の注意をご参照ください。Please refer to Precaution for additional process when additional process.

許容伝達動力表 曲げ強さ (kW)

Allowable transfer capability table (kW) Bending Strength

歯数 z	歯幅 b	焼入 H	回転速度 (min ⁻¹) revolution/min						
			10	100	200	400	800	1,200	1,500
50	10	-	0.059	0.59	1.19	2.20	3.66	5.18	6.28
50	15	-	0.090	0.890	1.790	3.290	5.470	7.740	9.380
50	15	○	0.095	0.948	1.896	3.518	5.929	8.424	10.429
50	16	-	0.096	0.96	1.92	3.53	5.86	8.30	10.05

The above references are JGMA standard.

動力の換算式は P26 をご参照ください。Please refer to the conversion formulas of power on page P26.

許容伝達動力表 歯面強さ (kW)

Allowable transfer capability table (kW) Surface Durability

回転速度 (min ⁻¹) revolution/min						
10	100	200	400	800	1,200	1,500
-	-	-	-	-	-	-
0.008	0.080	0.160	0.300	0.520	0.760	0.950
0.035	0.384	0.792	1.515	2.631	3.805	4.757
-	-	-	-	-	-	-

平歯車

SPUR GEARS

モジュール
MODULE

1.5

圧力角 20° (並歯) 歯数 52 ~ 55
20° PRESSURE ANGLE FULL DEPTH TOOTH Z 52 to Z 55

JIS B 1702-1 (ISO) 8 級
System of accuracy : JIS B 1702-1(ISO) class 8



New 仕様変更 省スペース・軽量化。
Specification change Space-saving and weight saving.

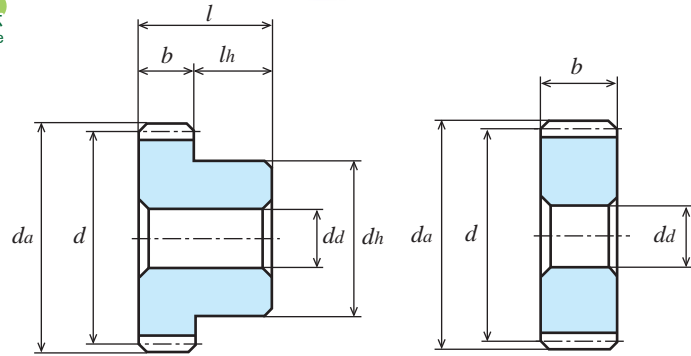

B1形
TYPE B1

A1形
TYPE A1

S45C 機械構造用炭素鋼 (JIS G 4051) Material : Carbon Steel (ISO C45)

単位 : mm
Dimensions : mm

商品記号 Catalogue Number	歯数 Number of Teeth z	基準円直径 Reference Diameter d	歯先円直径 Tip Diameter d_a	形 Type	歯幅 Face Width b	穴径 Bore Diameter $d_a(H7)$	ハブ外径 Hub Diameter d_h	ハブ長さ Hub Projection l_h	全長 Overall Length l	キミぞ Key Way $b_2 \times t_2$	重量 Weight $W(g)$
S1.5S 52A - 1014F	52	$\phi 78$	$\phi 81$	A1	10	$\phi 14$	-	-	10	-	363.0
S1.5S 52A - 1616F	52	$\phi 78$	$\phi 81$	A1	16	$\phi 16$	-	-	16	-	574.9
S1.5S 52B - 1014F	52	$\phi 78$	$\phi 81$	B1	10	$\phi 14$	$\phi 50$	10	20	-	505.1
S1.5S 52B - 1616	52	$\phi 78$	$\phi 81$	B1	16	$\phi 16$	$\phi 60$	10	26	-	781.6
S1.5S 54A - 1014F	54	$\phi 81$	$\phi 84$	A1	10	$\phi 14$	-	-	10	-	392.4
S1.5S 54A - 1616F	54	$\phi 81$	$\phi 84$	A1	16	$\phi 16$	-	-	16	-	622.0
S1.5S 54B - 1014F	54	$\phi 81$	$\phi 84$	B1	10	$\phi 14$	$\phi 50$	10	20	-	534.5
S1.5S 54B - 1616	54	$\phi 81$	$\phi 84$	B1	16	$\phi 16$	$\phi 60$	10	26	-	828.7
S1.5S 55A - 1014F	55	$\phi 82.5$	$\phi 85.5$	A1	10	$\phi 14$	-	-	10	-	407.5
S1.5S 55A - 1616F	55	$\phi 82.5$	$\phi 85.5$	A1	16	$\phi 16$	-	-	16	-	646.2
S1.5S 55B - 1014F	55	$\phi 82.5$	$\phi 85.5$	B1	10	$\phi 14$	$\phi 50$	10	20	-	549.6
S1.5S 55B - 1616	55	$\phi 82.5$	$\phi 85.5$	B1	16	$\phi 16$	$\phi 60$	10	26	-	852.9

許容伝達動力表 曲げ強さ (kW)

Allowable transfer capability table (kW) Bending Strength

歯数 z	歯幅 b	回転速度 (min ⁻¹) revolution/min							回転速度 (min ⁻¹) revolution/min
		10	100	200	400	800	1,200	1,500	100
52	10	0.062	0.62	1.25	2.29	3.82	5.40	6.55	59.20
52	16	0.101	1.01	2.01	3.67	6.12	8.65	10.49	96.45
54	10	0.065	0.65	1.31	2.38	3.98	5.62	6.82	62.07
54	16	0.105	1.05	2.10	3.81	6.38	9.00	10.92	100.27
55	10	0.067	0.67	1.34	2.42	4.06	5.73	6.96	63.98
55	16	0.108	1.08	2.15	3.88	6.51	9.18	11.14	103.13

The above numerical values are equivalent to JGMA formulas as reference only.

動力の換算式は P26 をご参照ください。Please refer to the conversion fomulas of power on page P26.

平歯車 SPUR GEARS

モジュール
MODULE

1.5

圧力角 20° (並歯) 歯数 56 58

20° PRESSURE ANGLE FULL DEPTH TOOTH Z 56 to Z 58

JIS B 1702-1 (ISO) 8 級
System of accuracy : JIS B 1702-1(ISO) class 8



御注文には必ず“フルネームで商品記号”を明記してください。

Please refer to the catalogue reference while ordering.

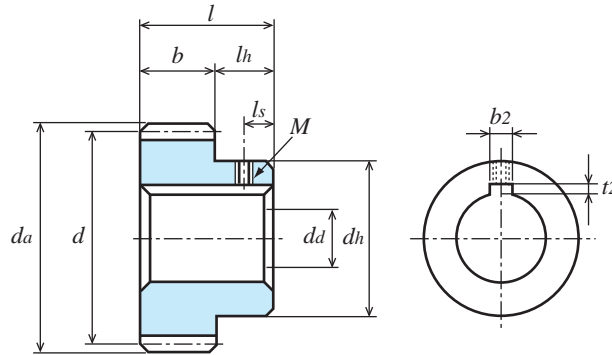

B1形
TYPE B1

S45C 機械構造用炭素鋼 (JIS G 4051) Material : Carbon Steel (ISO C45)

単位 : mm
Dimensions : mm

商品記号 Catalogue Number	歯数 Number of Teeth z	基準円直径 Reference Diameter d	歯先円直径 Outside Diameter da	形 Type	歯幅 Face Width b	穴径 Bore Diameter da(H7)	ハブ 外径 Hub Diameter dh	ハブ 長さ Hub Projection lh	全長 Overall Length l	キ み ぞ Key Way b ₂ × t ₂	ねじ Set Screw		リム内径 Dimension of Rim di	ウェブ 厚さ Thickness of Web b _w	重量 Weight W(g)
											M	ls			
S1.5S 56A - 1014F	56	φ84	φ87	A1	10	φ14	-	-	10	-	-	-	-	422.9	
S1.5S 56A = 1015	56	φ84	φ87	A1	10	φ15	-	-	10	5 × 2.3	-	-	-	420.3	
S1.5S 56A = 1018	56	φ84	φ87	A1	10	φ18	-	-	10	6 × 2.8	-	-	-	413.7	
S1.5S 56A - 1616F	56	φ84	φ87	A1	16	φ16	-	-	16	-	-	-	-	670.8	
S1.5S 56A = 1620	56	φ84	φ87	A1	16	φ20	-	-	16	6 × 2.8	-	-	-	654.5	
S1.5S 56B - 1014	56	φ84	φ87	B1	10	φ14	φ40	10	20	-	-	-	-	509.8	
S1.5S 56B # 1015	56	φ84	φ87	B1	10	φ15	φ40	10	20	5 × 2.3	M4	5	-	503.6	
S1.5S 56B - 1616	56	φ84	φ87	B1	16	φ16	φ50	10	26	-	-	-	-	809.7	
S1.5S 56B # 1620	56	φ84	φ87	B1	16	φ20	φ50	10	26	6 × 2.8	M5	5	-	781.6	
S1.5S 58A - 1014F	58	φ87	φ90	A1	10	φ14	-	-	10	-	-	-	-	454.6	
S1.5S 58A - 1616F	58	φ87	φ90	A1	16	φ16	-	-	16	-	-	-	-	721.4	
S1.5S 58B - 1014F	58	φ87	φ90	B1	10	φ14	φ50	10	20	-	-	-	-	596.6	
S1.5S 58B - 1616	58	φ87	φ90	B1	16	φ16	φ60	10	26	-	-	-	-	928.2	

【=】 (イコール) にはキー材が付いております。 [=] : Gear with key way / with key

【#】 (シャープ) にはキー材とセットスクリューが付いております。 [#] : Gear with key way and threaded hole / with key and screw.

許容伝達動力表 曲げ強さ (kW)

Allowable transfer capability table (kW) Bending Strength

歯数 z	歯幅 b	回転速度 (min ⁻¹) revolution/min							回転速度 (min ⁻¹) revolution/min
		10	100	200	400	800	1,200	1,500	
56	10	0.068	0.68	1.37	2.46	4.14	5.85	7.09	100
56	16	0.110	1.10	2.20	3.95	6.64	9.37	11.35	105.04
58	10	0.071	0.71	1.43	2.55	4.30	6.07	7.36	67.80
58	16	0.115	1.15	2.29	4.09	6.89	9.73	11.78	109.82

KG 規格は“並幅” (軽荷重用) と“広幅” (重荷重用) があります。ご用途に応じてお選び下さい。

KG STOCK GEARS has Wide-face width for Heavy load, and Standard-face width for Light load.

You are able to multiple choices for your suitable design from our wide range.

The above numerical values are equivalent to JGMA formulas as reference only.

動力の換算式は P26 をご参照ください。 Please refer to the conversion fomulas of power on page P26.

目次
CONTENTS

インフォメーション
INFORMATION

ギヤボックス
GEAR BOXES

ノーバッキングギヤ
ANTI BACKLASH SPUR GEARS

歯研平歯車
GROUND SPUR GEARS

歯研平歯車
SPUR GEARS

内歯車
INTERNAL GEARS

歯研ラック
GROUND RACKS

ラック
RACKS

へリカル・スクリューギヤ
HELICAL GEARS AND SCREW GEARS

ウォーム・ウォームギヤ
WORMS AND WORM GEARS

かさ歯車
BEVEL GEARS

スプロケット
SPROCKETS

技術資料
REFERENCE DATA

平歯車 SPUR GEARS

モジュール **1.5** 圧力角 20° (並歯) 歯数 60
 MODULE 20° PRESSURE ANGLE FULL DEPTH TOOTH Z 60

JIS B 1702-1 (ISO) 8級 (高周波焼入品: 9級)
 System of accuracy: JIS B 1702-1(ISO) class 8
 (Induction hardened products: class 9)



New 仕様変更 省スペース・軽量化、締結加工不要。
 Specification change Space-saving and weight saving.
 Additional machining on tightening is not necessary.

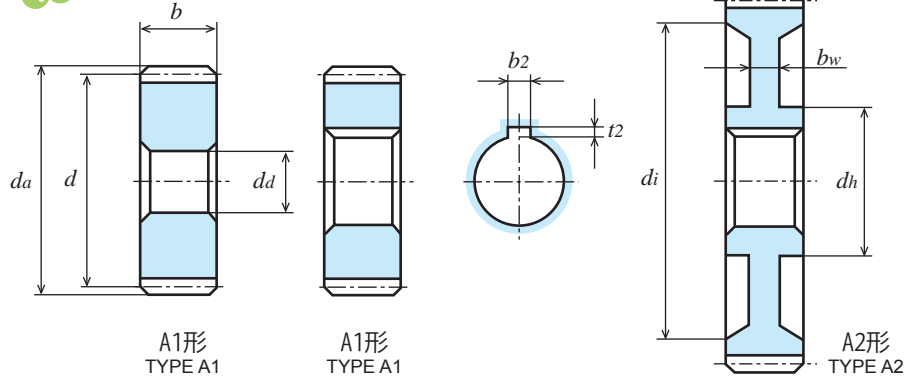

S45C 機械構造用炭素鋼 (JIS G 4051) Material: Carbon Steel (ISO C45)

単位: mm
 Dimensions: mm

商品記号 Catalogue Number	歯数 Number of Teeth z	基準円直径 Reference Diameter d	歯先円直径 Outside Diameter da	形 Type	歯幅 Face Width b	穴径 Bore Diameter da(H7)	ハブ外径 Hub Diameter dh	ハブ長さ Hub Projection lh	全長 Overall Length l	キミぞ Key Way b2 × t2	ねじ Set Screw		リム内径 Dimension of Rim di	ウェブ厚さ Thickness of Web bw	重量 Weight W(g)
											M	ls			
S1.5S 60A - 1014F	60	φ90	φ93	A1	10	φ14	-	-	10	-	-	-	-	487.3	
S1.5S 60A = 1015	60	φ90	φ93	A1	10	φ15	-	-	10	5 × 2.3	-	-	-	484.6	
S1.5S 60A = 1018	60	φ90	φ93	A1	10	φ18	-	-	10	6 × 2.8	-	-	-	478.1	
S1.5S 60A = 1020	60	φ90	φ93	A1	10	φ20	-	-	10	6 × 2.8	-	-	-	473.4	
S1.5S 60A - 1616F	60	φ90	φ93	A1	16	φ16	-	-	16	-	-	-	-	773.8	
S1.5S 60A = 1620	60	φ90	φ93	A2	16	φ20	φ40	-	16	6 × 2.8	-	-	φ76	8	568.5
S1.5S 60A = 1625	60	φ90	φ93	A2	16	φ25	φ50	-	16	8 × 3.3	-	-	φ76	8	589.4
S1.5S 60B - 1014	60	φ90	φ93	B1	10	φ14	φ40	10	20	-	-	-	-	572.2	
S1.5S 60B # 1015	60	φ90	φ93	B1	10	φ15	φ40	10	20	5 × 2.3	M4	5	-	568.0	
S1.5S 60B # 1018	60	φ90	φ93	B1	10	φ18	φ40	10	20	6 × 2.8	M5	5	-	554.8	
S1.5S 60B # 1020	60	φ90	φ93	B1	10	φ20	φ40	10	20	6 × 2.8	M5	5	-	545.5	
● S1.5S 60BF - 1510	60	φ90	φ93	B1	15	φ10(H8)	φ65	15	30	-	-	-	-	1,118.4	
● S1.5S 60B - 1510H	60	φ90	φ93	B1	15	φ10(H※)	φ65	15	30	-	-	-	-	1,118.4	
S1.5S 60B - 1616	60	φ90	φ93	B1	16	φ16	φ50	10	26	-	-	-	-	912.7	
S1.5S 60B # 1620	60	φ90	φ93	B3	16	φ20	φ50	10	26	6 × 2.8	M5	5	φ76	8	739.6
S1.5S 60B # 1625	60	φ90	φ93	B3	16	φ25	φ50	10	26	8 × 3.3	M6	5	φ76	8	701.4

● の商品は新商品です。Products with ● marks are new item.

【=】(イコール)にはキー材が付いております。 [=]: Gear with key way / with key

【#】(シャープ)にはキー材とセットスクリューが付いております。 [#]: Gear with key way and threaded hole / with key and screw.

カタログ記号の末尾に【H】を付した商品は歯部高周波焼入済です。 Gear tooth surface completed with induction hardening, Hardness HRC47 to 53.

※ 歯部高周波焼入後の穴修正は行っていません。 Bore correcting after induction hardening is not completed.

追加加工の際は、追加加工時の注意をご参照ください。 Please refer to Precaution for additional process when additional process.

許容伝達動力表 曲げ強さ (kW)

Allowable transfer capability table (kW) Bending Strength

歯数 z	歯幅 b	焼入 H	回転速度 (min ⁻¹) revolution/min						
			10	100	200	400	800	1,200	1,500
60	10	-	0.074	0.74	1.49	2.63	4.46	6.30	7.62
60	15	-	0.110	1.110	2.230	3.930	6.660	9.400	11.380
60	15	○	0.118	1.181	2.363	4.217	7.227	10.396	12.995
60	16	-	0.120	1.20	2.39	4.22	7.14	10.09	12.20

The above references are JGMA standard.

動力の換算式は P26 をご参照ください。 Please refer to the conversion formulas of power on page P26.

許容伝達動力表 歯面強さ (kW)

Allowable transfer capability table (kW) Surface Durability

回転速度 (min ⁻¹) revolution/min						
10	100	200	400	800	1,200	1,500
-	-	-	-	-	-	-
0.011	0.120	0.230	0.420	0.750	1.120	1.400
0.051	0.563	1.160	2.134	3.771	5.522	6.970
-	-	-	-	-	-	-

平歯車 SPUR GEARS

モジュール **1.5** 圧力角 20° (並歯) 歯数 64 ~ 68
 MODULE 20° PRESSURE ANGLE FULL DEPTH TOOTH Z 64 to Z 68

JIS B 1702-1 (ISO) 8 級
 System of accuracy : JIS B 1702-1(ISO) class 8



御注文には必ず“フルネームで商品記号”を明記してください。
 Please refer to the catalogue reference while ordering.

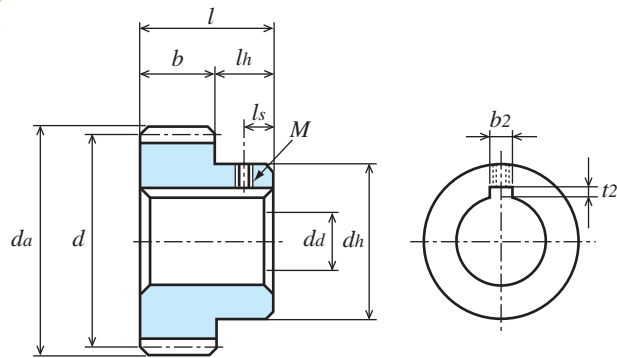

B1形
TYPE B1

S45C 機械構造用炭素鋼 (JIS G 4051) Material : Carbon Steel (ISO C45)

単位 : mm
 Dimensions : mm

商品記号 Catalogue Number	歯数 Number of Teeth z	基準円直径 Reference Diameter d	歯先円直径 Outside Diameter da	形 Type	歯幅 Face Width b	穴径 Bore Diameter da(H7)	ハブ外径 Hub Diameter dh	ハブ長さ Hub Projection lh	全長 Overall Length l	キミぞ Key Way b2 × t2	ねじ Set Screw		リム内径 Dimension of Rim di	ウエブ厚さ Thickness of Web bw	重量 Weight W(kg)
											M	ls			
S1.5S 64A - 1014F	64	φ 96	φ 99	A1	10	φ14	-	-	10	-	-	-	-	0.56	
S1.5S 64A = 1015	64	φ 96	φ 99	A1	10	φ15	-	-	10	5 × 2.3	-	-	-	0.55	
S1.5S 64A = 1018	64	φ 96	φ 99	A1	10	φ18	-	-	10	6 × 2.8	-	-	-	0.55	
S1.5S 64A - 1616F	64	φ 96	φ 99	A1	16	φ16	-	-	16	-	-	-	-	0.88	
S1.5S 64A = 1620	64	φ 96	φ 99	A2	16	φ20	φ40	-	16	6 × 2.8	-	-	φ82	8	0.63
S1.5S 64B - 1014	64	φ 96	φ 99	B1	10	φ14	φ40	10	20	-	-	-	-	0.64	
S1.5S 64B # 1015	64	φ 96	φ 99	B1	10	φ15	φ40	10	20	5 × 2.3	M4	5	-	0.64	
S1.5S 64B - 1616	64	φ 96	φ 99	B1	16	φ16	φ50	10	26	-	-	-	-	1.02	
S1.5S 64B # 1620	64	φ 96	φ 99	B3	16	φ20	φ50	10	26	6 × 2.8	M5	5	φ82	8	0.80
S1.5S 68A - 1014F	68	φ 102	φ 105	A1	10	φ14	-	-	10	-	-	-	-	0.63	
S1.5S 68A - 1616F	68	φ 102	φ 105	A1	16	φ16	-	-	16	-	-	-	-	1.00	
S1.5S 68B - 1014F	68	φ 102	φ 105	B1	10	φ14	φ50	10	20	-	-	-	-	0.77	
S1.5S 68B - 1616	68	φ 102	φ 105	B1	16	φ16	φ60	10	26	-	-	-	-	1.14	

【=】(イコール)にはキー材が付いております。【=】: Gear with key way / with key
 【#】(シャープ)にはキー材とセットスクリーンが付いております。【#】: Gear with key way and threaded hole / with key and screw.

許容伝達動力表 曲げ強さ (kW)

Allowable transfer capability table (kW) Bending Strength

歯数 z	歯幅 b	回転速度 (min ⁻¹) revolution/min							100
		10	100	200	400	800	1,200	1,500	
64	10	0.080	0.80	1.61	2.80	4.77	6.74	8.15	76.39
64	16	0.129	1.29	2.58	4.48	7.64	10.80	13.04	123.19
68	10	0.087	0.87	1.72	2.96	5.08	7.19	8.67	83.08
68	16	0.139	1.39	2.75	4.74	8.14	11.50	13.87	132.74

KG 規格は“並幅”(軽荷重用)と“広幅”(重荷重用)があります。ご用途に応じてお選び下さい。

KG STOCK GEARS has Wide-face width for Heavy load, and Standard-face width for Light load.

You are able to multiple choices for your suitable design from our wide range.

The above numerical values are equivalent to JGMA formulas as reference only.

動力の換算式は P26 をご参照ください。Please refer to the conversion fomulas of power on page P26.

T (N · m)

目次
CONTENTS

インフォメーション
INFORMATION

ギヤボックス
GEAR BOXES

ノーバックラッシュギヤ
ANTI BACKLASH SPUR GEARS

歯研平歯車
GROUND SPUR GEARS

歯研平歯車
SPUR GEARS

内歯車
INTERNAL GEARS

歯研ラック
GROUND RACKS

ラック
RACKS

ハニカムギヤ
HEXAGONAL GEARS AND SCREW GEARS

ウォーム
WORMS AND WORM WHEELS

かさ歯車
BEVEL GEARS

スプロケット
SPROCKETS

技術資料
REFERENCE DATA

平歯車

SPUR GEARS

モジュール **1.5** 圧力角 20° (並歯) 歯数 70
 MODULE 20° PRESSURE ANGLE FULL DEPTH TOOTH Z 70

JIS B 1702-1 (ISO) 8 級
 System of accuracy : JIS B 1702-1(ISO) class 8



New 仕様変更 省スペース・軽量化、締結加工不要。
 Specification change Space-saving and weight saving.
 Additional machining on tightening is not necessary.

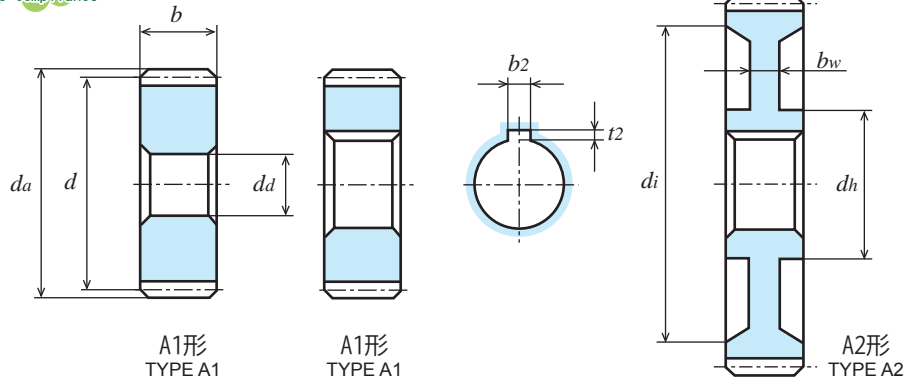

S45C 機械構造用炭素鋼 (JIS G 4051)

Material : Carbon Steel (ISO C45)

単位 : mm
 Dimensions : mm

商品記号 Catalogue Number	歯数 Number of Teeth z	基準円直径 Reference Diameter d	歯先円直径 Outside Diameter da	形 Type	歯幅 Face Width b	穴径 Bore Diameter da(H7)	ハブ外径 Hub Diameter dh	ハブ長さ Hub Projection lh	全長 Overall Length l	キーマイぞ Key Way b2 × t2	ねじ Set Screw		リム内径 Dimension of Rim di	ウェブ厚さ Thickness of Web bw	重量 Weight W(kg)
											M	ls			
S1.5S 70A - 1014F	70	φ105	φ108	A1	10	φ14	-	-	10	-	-	-	-	0.67	
S1.5S 70A = 1015	70	φ105	φ108	A1	10	φ15	-	-	10	5 × 2.3	-	-	-	0.67	
S1.5S 70A = 1018	70	φ105	φ108	A1	10	φ18	-	-	10	6 × 2.8	-	-	-	0.66	
S1.5S 70A - 1616F	70	φ105	φ108	A1	16	φ16	-	-	16	-	-	-	-	1.06	
S1.5S 70A = 1620	70	φ105	φ108	A2	16	φ20	φ40	-	16	6 × 2.8	-	-	φ91	8	0.74
S1.5S 70B - 1014	70	φ105	φ108	B1	10	φ14	φ40	10	20	-	-	-	-	0.75	
S1.5S 70B # 1015	70	φ105	φ108	B1	10	φ15	φ40	10	20	5 × 2.3	M4	5	-	0.75	
S1.5S 70BF - 1510	70	φ105	φ108	B1	15	φ10(H8)	φ75	15	30	-	-	-	-	1.52	
S1.5S 70B - 1510H	70	φ105	φ108	B1	15	φ10(H※)	φ75	15	30	-	-	-	-	1.52	
S1.5S 70B - 1616	70	φ105	φ108	B1	16	φ16	φ50	10	26	-	-	-	-	1.20	
S1.5S 70B # 1620	70	φ105	φ108	B3	16	φ20	φ50	10	26	6 × 2.8	M5	5	φ91	8	0.94

●の商品は新商品です。Products with ● marks are new item.

【=】 (イコール) にはキーマ材が付いております。 [=] : Gear with key way / with key
 【#】 (シャープ) にはキーマ材とセットスクリューが付いております。 [#] : Gear with key way and threaded hole / with key and screw.

カタログ記号の末尾に【H】を付した商品は歯部高周波焼入済です。Gear tooth surface completed with induction hardening, Hardness HRC47 to 53.

※
 歯部高周波焼入後の穴修正は行っていません。Bore correcting after induction hardening is not completed.
 追加加工の際は、追加加工時の注意をご参照ください。Please refer to Precaution for additional process when additional process.

許容伝達動力表 曲げ強さ (kW)

Allowable transfer capability table (kW) Bending Strength

歯数 z	歯幅 b	焼入 H	回転速度 (min ⁻¹) revolution/min						
			10	100	200	400	800	1,200	1,500
70	10	-	0.089	0.90	1.77	3.04	5.24	7.41	8.97
70	15	-	0.130	0.140	2.630	4.530	7.810	11.040	13.370
70	15	○	0.142	1.417	2.796	4.871	8.483	12.469	15.587
70	16	-	0.143	1.43	2.83	4.86	8.38	11.85	14.35

The above references are JGMA standard.

動力の換算式は P26 をご参照ください。Please refer to the conversion formulas of power on page P26.

許容伝達動力表 歯面強さ (kW)

Allowable transfer capability table (kW) Surface Durability

回転速度 (min ⁻¹) revolution/min						
10	100	200	400	800	1,200	1,500
-	-	-	-	-	-	-
0.016	0.160	0.320	0.570	1.030	1.550	1.930
0.070	0.777	1.581	2.839	5.097	7.627	9.627
-	-	-	-	-	-	-

平歯車

SPUR GEARS

モジュール
MODULE

1.5

圧力角 20° (並歯) 歯数 72 75

20° PRESSURE ANGLE FULL DEPTH TOOTH Z72 to Z75

JIS B 1702-1 (ISO) 8級
System of accuracy: JIS B 1702-1(ISO) class 8



御注文には必ず“フルネームで商品記号”を明記してください。

Please refer to the catalogue reference while ordering.

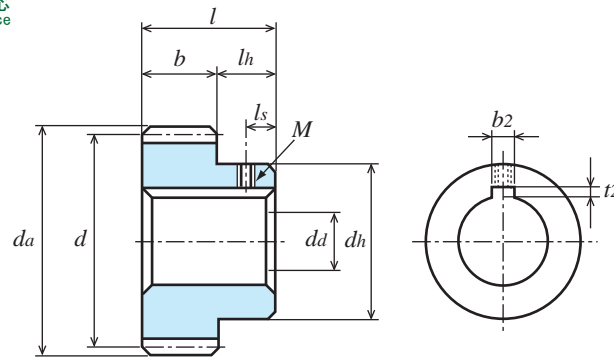

B1形
TYPE B1

S45C 機械構造用炭素鋼 (JIS G 4051)

Material: Carbon Steel (ISO C45)

単位: mm
Dimensions: mm

商品記号 Catalogue Number	歯数 Number of Teeth z	基準円直径 Reference Diameter d	歯先円直径 Outside Diameter da	形 Type	歯幅 Face Width b	穴径 Bore Diameter da(H7)	ハブ外径 Hub Diameter dh	ハブ長さ Hub Projection lh	全長 Overall Length l	キーマイぞ Key Way b2 × t2	ねじ Set Screw		リム内径 Dimension of Rim di	ウェブ厚さ Thickness of Web bw	重量 Weight W(kg)
											M	ls			
S1.5S 72A - 1016F	72	φ108	φ111	A1	10	φ16	-	-	10	-	-	-	-	0.70	
S1.5S 72A = 1018	72	φ108	φ111	A1	10	φ18	-	-	10	6 × 2.8	-	-	-	0.70	
S1.5S 72A = 1020	72	φ108	φ111	A1	10	φ20	-	-	10	6 × 2.8	-	-	-	0.69	
S1.5S 72A - 1618F	72	φ108	φ111	A1	16	φ18	-	-	16	-	-	-	-	1.12	
S1.5S 72A = 1620	72	φ108	φ111	A2	16	φ20	φ40	-	16	6 × 2.8	-	-	φ94	8	0.77
S1.5S 72A = 1625	72	φ108	φ111	A2	16	φ25	φ50	-	16	8 × 3.3	-	-	φ94	8	0.79
S1.5S 72B - 1016	72	φ108	φ111	B1	10	φ16	φ40	10	20	-	-	-	-	0.79	
S1.5S 72B # 1018	72	φ108	φ111	B1	10	φ18	φ40	10	20	6 × 2.8	M5	5	-	0.77	
S1.5S 72B - 1618	72	φ108	φ111	B1	16	φ18	φ50	10	26	-	-	-	-	1.25	
S1.5S 72B # 1620	72	φ108	φ111	B3	16	φ20	φ50	10	26	6 × 2.8	M5	5	φ94	8	0.94
S1.5S 75A - 1016F	75	φ112.5	φ115.5	A1	10	φ16	-	-	10	-	-	-	-	0.76	
S1.5S 75A - 1618F	75	φ112.5	φ115.5	A1	16	φ18	-	-	16	-	-	-	-	1.22	
S1.5S 75B - 1016F	75	φ112.5	φ115.5	B1	10	φ16	φ50	10	20	-	-	-	-	0.90	
S1.5S 75B - 1618	75	φ112.5	φ115.5	B1	16	φ18	φ60	10	26	-	-	-	-	1.42	

【=】(イコール)にはキー材が付いております。【=】: Gear with key way / with key

【#】(シャープ)にはキー材とセットスクリューが付いております。【#】: Gear with key way and threaded hole / with key and screw.

許容伝達動力表 曲げ強さ (kW)

Allowable transfer capability table (kW) Bending Strength

歯数 z	歯幅 b	回転速度 (min ⁻¹) revolution/min							回転速度 (min ⁻¹) revolution/min	
		10	100	200	400	800	1,200	1,500		
72	10	0.092	0.93	1.82	3.12	5.39	7.62	9.27	100	88.81
72	16	0.148	1.48	2.91	4.99	8.62	12.19	14.83	100	141.33
75	10	0.097	0.97	1.89	3.23	5.61	7.94	9.72	100	92.63
75	16	0.156	1.56	3.03	5.17	8.98	12.71	15.56	100	148.97

KG規格は“並幅”(軽荷重用)と“広幅”(重荷重用)があります。ご用途に応じてお選び下さい。

KG STOCK GEARS has Wide-face width for Heavy load, and Standard-face width for Light load.

You are able to multiple choices for your suitable design from our wide range.

The above numerical values are equivalent to JGMA formulas as reference only.

動力の換算式はP26をご参照ください。Please refer to the conversion fomulas of power on page P26.

目次
CONTENTS
インフォメーション
INFORMATION
ギヤボックス
GEAR BOXES
ノーバッキングスピギヤ
ANTI BACKLASH SPUR GEARS
歯研平歯車
GROUND SPUR GEARS
歯研平歯車
SPUR GEARS
内歯車
INTERNAL GEARS
歯研ラック
GROUND RACKS
ラック
RACKS
へリカル・スクリューギヤ
HELICAL GEARS AND SCREW GEARS
ワーム・ワームホイール
WORMS AND WORM WHEELS
かさ歯車
BEVEL GEARS
スプロケット
SPROCKETS
技術資料
REFERENCE DATA

平歯車

SPUR GEARS

モジュール **1.5** 圧力角 20° (並歯) 歯数 80
 MODULE 20° PRESSURE ANGLE FULL DEPTH TOOTH Z 80

JIS B 1702-1 (ISO) 8級
 System of accuracy: JIS B 1702-1(ISO) class 8



New 仕様変更 省スペース・軽量化、締結加工不要。
 Specification change Space-saving and weight saving.
 Additional machining on tightening is not necessary.

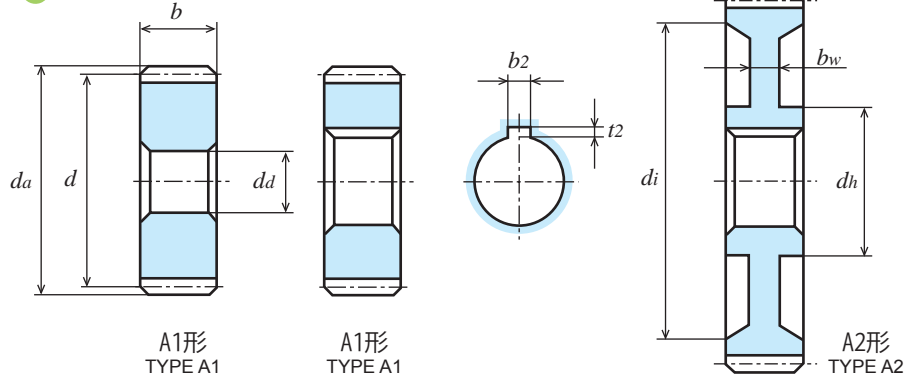

S45C 機械構造用炭素鋼 (JIS G 4051)

Material: Carbon Steel (ISO C45)

単位: mm
 Dimensions: mm

商品記号 Catalogue Number	歯数 Number of Teeth <i>z</i>	基準円直径 Reference Diameter <i>d</i>	歯先円直径 Outside Diameter <i>d_a</i>	形 Type	歯幅 Face Width <i>b</i>	穴径 Bore Diameter <i>d_a(H7)</i>	ハブ外径 Hub Diameter <i>d_h</i>	ハブ長さ Hub Projection <i>l_h</i>	全長 Overall Length <i>l</i>	キミぞ Key Way <i>b₂ × t₂</i>	ねじ Set Screw		リム内径 Dimension of Rim <i>d_i</i>	ウェブ厚さ Thickness of Web <i>b_w</i>	重量 Weight <i>W(kg)</i>
											<i>M</i>	<i>l_s</i>			
S1.5S 80A - 1016F	80	φ120	φ123	A1	10	φ16	-	-	10	-	-	-	-	-	0.87
S1.5S 80A = 1018	80	φ120	φ123	A1	10	φ18	-	-	10	6 × 2.8	-	-	-	-	0.87
S1.5S 80A = 1020	80	φ120	φ123	A1	10	φ20	-	-	10	6 × 2.8	-	-	-	-	0.86
S1.5S 80A - 1618F	80	φ120	φ123	A1	16	φ18	-	-	16	-	-	-	-	-	1.39
S1.5S 80A = 1620	80	φ120	φ123	A2	16	φ20	φ40	-	16	6 × 2.8	-	-	φ106	8	0.93
S1.5S 80A = 1625	80	φ120	φ123	A2	16	φ25	φ50	-	16	8 × 3.3	-	-	φ106	8	0.95
S1.5S 80B - 1016	80	φ120	φ123	B1	10	φ16	φ40	10	20	-	-	-	-	-	0.96
S1.5S 80B # 1018	80	φ120	φ123	B1	10	φ18	φ40	10	20	6 × 2.8	M5	5	-	-	0.94
S1.5S 80B # 1020	80	φ120	φ123	B1	10	φ20	φ40	10	20	6 × 2.8	M5	5	-	-	0.93
● S1.5S 80BF - 1510	80	φ120	φ123	B1	15	φ10(H8)	φ85	15	30	-	-	-	-	-	2.0
● S1.5S 80B - 1510H	80	φ120	φ123	B1	15	φ10(H※)	φ85	15	30	-	-	-	-	-	2.0
S1.5S 80B - 1618	80	φ120	φ123	B1	16	φ18	φ50	10	26	-	-	-	-	-	1.52
S1.5S 80B # 1620	80	φ120	φ123	B3	16	φ20	φ50	10	26	6 × 2.8	M5	5	φ106	8	1.10
S1.5S 80B # 1625	80	φ120	φ123	B3	16	φ25	φ50	10	26	8 × 3.3	M6	5	φ106	8	1.06

● の商品は新商品です。Products with ● marks are new item.

【=】 (イコール) にはキー材が付いております。 [=]: Gear with key way / with key

【#】 (シャープ) にはキー材とセットスクリューが付いております。 [#]: Gear with key way and threaded hole / with key and screw.

※

許容伝達動力表 曲げ強さ (kW)

Allowable transfer capability table (kW) Bending Strength

歯数 <i>z</i>	歯幅 <i>b</i>	焼入 <i>H</i>	回転速度 (min ⁻¹) revolution/min						
			10	100	200	400	800	1,200	1,500
80	10	-	0.10	1.05	2.02	3.42	5.98	8.47	10.48
80	15	-	0.16	1.56	3.01	5.09	8.91	12.61	15.60
80	15	○	0.165	1.65	3.20	5.49	9.71	14.56	18.20
80	16	-	0.17	1.68	3.23	5.47	9.57	13.55	16.76

The above references are JGMA standard.

動力の換算式は P26 をご参照ください。Please refer to the conversion formulas of power on page P26.

許容伝達動力表 歯面強さ (kW)

Allowable transfer capability table (kW) Surface Durability

回転速度 (min ⁻¹) revolution/min						
10	100	200	400	800	1,200	1,500
-	-	-	-	-	-	-
0.021	0.210	0.420	0.730	1.360	2.040	2.610
0.093	1.028	2.048	3.623	6.607	10.089	12.735
-	-	-	-	-	-	-

平歯車

SPUR GEARS

モジュール **1.5** 圧力角 20° (並歯) 歯数 84 90
 MODULE 20° PRESSURE ANGLE FULL DEPTH TOOTH Z 84 to Z 90

JIS B 1702-1 (ISO) 8級 (高周波焼入品: 9級)
 System of accuracy: JIS B 1702-1(ISO) class 8
 (Induction hardened products: class 9)



御注文には必ず“フルネームで商品記号”を明記してください。
 Please refer to the catalogue reference while ordering.

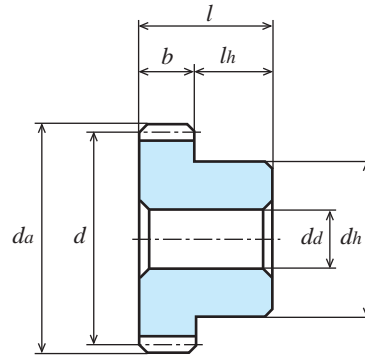

B1形
TYPE B1

S45C 機械構造用炭素鋼 (JIS G 4051)

Material: Carbon Steel (ISO C45)

単位: mm
Dimensions: mm

商品記号 Catalogue Number	歯数 Number of Teeth z	基準円直径 Reference Diameter d	歯先円直径 Tip Diameter da	形 Type	歯幅 Face Width b	穴径 Bore Diameter da(H7)	ハブ外径 Hub Diameter dh	ハブ長さ Hub Projection lh	全長 Overall Length l	キミぞ Key Way b2 × t2	リム内径 Dimension of Rim di	ウェブ厚さ Thickness of Web bw	重量 Weight W(kg)
S1.5S 84A - 1016F	84	φ126	φ129	A1	10	φ16	-	-	10	-	-	-	0.96
S1.5S 84A - 1622F	84	φ126	φ129	A1	16	φ22	-	-	16	-	-	-	1.52
S1.5S 84B - 1016F	84	φ126	φ129	B1	10	φ16	φ60	10	20	-	-	-	1.17
S1.5S 84B - 1618	84	φ126	φ129	B1	16	φ18	φ70	10	26	-	-	-	1.82
S1.5S 90A - 1016F	90	φ135	φ138	A1	10	φ16	-	-	10	-	-	-	1.11
S1.5S 90A - 1622F	90	φ135	φ138	A1	16	φ22	-	-	16	-	-	-	1.75
S1.5S 90B - 1016F	90	φ135	φ138	B1	10	φ16	φ60	10	20	-	-	-	1.31
● S1.5S 90BF - 1512	90	φ135	φ138	B1	15	φ12	φ95	15	30	-	-	-	2.49
● S1.5S 90B - 1512H	90	φ135	φ138	B1	15	φ12(H※)	φ95	15	30	-	-	-	2.49
S1.5S 90B - 1618	90	φ135	φ138	B1	16	φ18	φ70	10	26	-	-	-	2.05

●の商品は新商品です。Products with ● marks are new item.

【=】(イコール)にはキー材が付いております。 [=]: Gear with key way / with key.

【#】(シャープ)にはキー材とセットスクリューが付いております。

カタログ記号の末尾に【H】を付した商品は歯部高周波焼入済です。 Gear tooth surface completed with induction hardening, Hardness HRC47 to 53.

※

歯部高周波焼入後の穴修正は行っていません。 Bore correcting after induction hardening is not completed.

追加工の際は、追加工時の注意をご参照ください。 Please refer to Precaution for additional process when additional process.

許容伝達動力表 曲げ強さ (kW)

Allowable transfer capability table (kW) Bending Strength

歯数 z	歯幅 b	焼入 H	回転速度 (min ⁻¹) revolution/min						
			10	100	200	400	800	1,200	1,500
90	10	-	0.12	1.20	2.26	3.76	6.74	9.59	-
90	15	-	0.180	1.780	3.360	5.600	10.030	14.270	-
90	15	○	0.189	1.891	3.579	6.054	11.091	16.636	-
90	16	-	0.19	1.92	3.61	6.02	10.79	15.34	-

The above references are JGMA standard.

動力の換算式は P26 をご参照ください。 Please refer to the conversion formulas of power on page P26.

許容伝達動力表 歯面強さ (kW)

Allowable transfer capability table (kW) Surface Durability

回転速度 (min ⁻¹) revolution/min						
10	100	200	400	800	1,200	1,500
-	-	-	-	-	-	-
0.027	0.270	0.520	0.900	1.750	2.640	-
0.119	1.316	2.568	4.477	8.456	12.912	-
-	-	-	-	-	-	-

目次
CONTENTS

インフォメーション
INFORMATION

ギヤボックス
GEAR BOXES

ノーマンバックス
ANTI BACKLASH SPUR GEARS

歯研削歯車
GROUND SPUR GEARS

平歯車
SPUR GEARS

内歯車
INTERNAL GEARS

歯研削ラック
GROUND RACKS

ラック
RACKS

ヘリカル・スクリューギヤ
HELICAL GEARS AND SCREW GEARS

ワーム・ワームホイール
WORMS AND WORM WHEELS

かさ歯車
BEVEL GEARS

スプロケット
SPROCKETS

技術資料
REFERENCE DATA

平歯車

SPUR GEARS

モジュール **1.5** 圧力角 20° (並歯) 歯数 100
 MODULE 20° PRESSURE ANGLE FULL DEPTH TOOTH Z 100

JIS B 1702-1 (ISO) 8級 (高周波焼入品: 9級)
 System of accuracy: JIS B 1702-1(ISO) class 8
 (Induction hardened products: class 9)



New 仕様変更 省スペース・軽量化、締結加工不要。
 Specification change Space-saving and weight saving.
 Additional machining on tightening is not necessary.

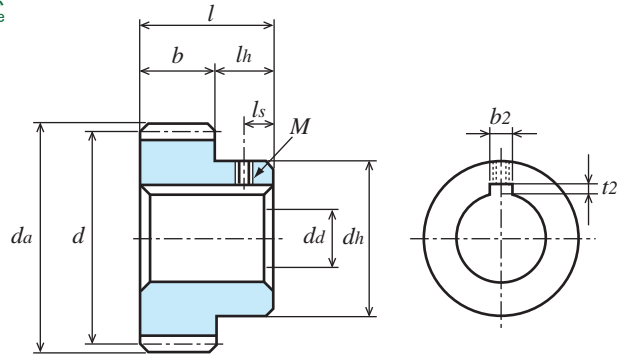

B1形
TYPE B1

S45C 機械構造用炭素鋼 (JIS G 4051)

Material: Carbon Steel (ISO C45)

単位: mm
Dimensions: mm

商品記号 Catalogue Number	歯数 Number of Teeth z	基準円直径 Reference Diameter d	歯先円直径 Outside Diameter da	形 Type	歯幅 Face Width b	穴径 Bore Diameter da(H7)	ハブ外径 Hub Diameter dh	ハブ長さ Hub Projection lh	全長 Overall Length l	キヤミぞ Key Way b2 × t2	ねじ Set Screw		リム内径 Dimension of Rim di	ウェブ厚さ Thickness of Web bw	重量 Weight W(kg)
											M	ls			
S1.5S 100A - 1016F	100	φ150	φ153	A1	10	φ16	-	-	10	-	-	-	-	1.37	
S1.5S 100A = 1018	100	φ150	φ153	A1	10	φ18	-	-	10	6 × 2.8	-	-	-	1.37	
S1.5S 100A = 1020	100	φ150	φ153	A1	10	φ20	-	-	10	6 × 2.8	-	-	-	1.36	
S1.5S 100A - 1618F	100	φ150	φ153	A1	16	φ18	-	-	16	-	-	-	-	2.19	
S1.5S 100A = 1620	100	φ150	φ153	A2	16	φ20	φ40	-	16	6 × 2.8	-	-	φ136	8	1.38
S1.5S 100A = 1625	100	φ150	φ153	A2	16	φ25	φ50	-	16	8 × 3.3	-	-	φ136	8	1.40
S1.5S 100B - 1016	100	φ150	φ153	B1	10	φ16	φ40	10	20	-	-	-	-	1.46	
S1.5S 100B # 1018	100	φ150	φ153	B1	10	φ18	φ40	10	20	6 × 2.8	M5	5	-	1.44	
S1.5S 100B # 1020	100	φ150	φ153	B1	10	φ20	φ40	10	20	6 × 2.8	M5	5	-	1.43	
S1.5S 100BF - 1515	100	φ150	φ153	B1	15	φ15	φ105	15	30	-	-	-	-	3.05	
S1.5S 100B - 1515H	100	φ150	φ153	B1	15	φ15(H※)	φ105	15	30	-	-	-	-	3.05	
S1.5S 100B - 1618	100	φ150	φ153	B1	16	φ18	φ50	10	26	-	-	-	-	2.32	
S1.5S 100B # 1620	100	φ150	φ153	B3	16	φ20	φ50	10	26	6 × 2.8	M5	5	φ136	8	1.55
S1.5S 100B # 1625	100	φ150	φ153	B3	16	φ25	φ50	10	26	8 × 3.3	M6	5	φ136	8	1.51

●の商品は新商品です。Products with ● marks are new item.

【=】(イコール)にはキー材が付いております。 [=]: Gear with key way / with key

【#】(シャープ)にはキー材とセットスクリューが付いております。 [#]: Gear with key way and threaded hole / with key and screw.

カタログ記号の末尾に【H】を付した商品は歯部高周波焼入済です。 Gear tooth surface completed with induction hardening, Hardness HRC47 to 53.

※
 歯部高周波焼入後の穴修正は行っていません。 Bore correcting after induction hardening is not completed.

追加加工の際は、追加加工時の注意をご参照ください。 Please refer to Precaution for additional process when additional process.

許容伝達動力表 曲げ強さ (kW)

Allowable transfer capability table (kW) Bending Strength

歯数 z	歯幅 b	焼入 H	回転速度 (min ⁻¹) revolution/min						
			10	100	200	400	800	1,200	1,500
100	10	-	0.14	1.35	2.49	4.13	7.49	10.80	-
100	15	-	0.200	2.010	3.700	6.150	11.140	16.070	-
100	15	○	0.213	2.129	3.951	6.659	12.492	18.738	-
100	16	-	0.22	2.16	3.98	6.61	11.98	17.28	-

The above references are JGMA standard.

動力の換算式はP26をご参照ください。 Please refer to the conversion formulas of power on page P26.

許容伝達動力表 歯面強さ (kW)

Allowable transfer capability table (kW) Surface Durability

回転速度 (min ⁻¹) revolution/min						
10	100	200	400	800	1,200	1,500
-	-	-	-	-	-	-
0.034	0.340	0.640	1.110	2.180	3.340	-
0.148	1.641	3.139	5.453	10.545	16.101	-
-	-	-	-	-	-	-

Memo

目次
CONTENTS

インフォメーション
INFORMATION

ギヤボックス
GEAR BOXES

ノーバッキングギヤ
ANTI BACKLASH SPUR GEARS

歯研平歯
GROUND SPUR GEARS

平歯
SPUR GEARS

内歯
INTERNAL GEARS

歯ラック
GROUND RACKS

ラック
RACKS

へりかき・スクリューギヤ
HELICAL GEARS AND SCREW GEARS

ワーム・ワームホイール
WORMS AND WORM WHEELS

かみ歯
BEVEL GEARS

スプロケット
SPROCKETS

技術資料
REFERENCE DATA

平歯車 SPUR GEARS

モジュール
MODULE

2

圧力角 20° (並歯)
20° PRESSURE ANGLE FULL DEPTH TOOTH

JIS B 1702-1 (ISO) 9~10 級
System of accuracy : JIS B 1702-1(ISO) class 9-10



New 仕様変更 省スペース・軽量化。
Specification change Space-saving and weight saving.

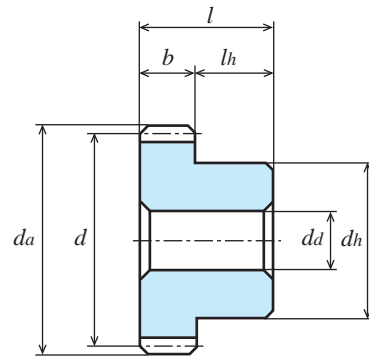

B1形
TYPE B1

ポリアセタール (黒色)
Material : Poly Acetal (Black)

単位 : mm
Dimensions : mm

商品記号 Catalogue Number	歯数 Number of Teeth z	基準円直径 Reference Diameter d	歯先円直径 Tip Diameter d_a	形 Type	歯幅 Face Width b	穴径 Bore Diameter d_d	ハブ外径 Hub Diameter d_h	ハブ長さ Hub Projection l_h	全長 Overall Length l	重量 Weight $W(g)$
▲ S2D 14B - 2010N	14	φ28	φ32	B1	20	φ10	φ22	10	30	19.4
▲ S2D 15B - 2010N	15	φ30	φ34	B1	20	φ10	φ24	10	30	23.0
▲ S2D 16B - 2012N	16	φ32	φ36	B1	20	φ12	φ26	10	30	25.4
▲ S2D 18B - 2012N	18	φ36	φ40	B1	20	φ12	φ30	10	30	33.9
▲ S2D 20B - 2012N	20	φ40	φ44	B1	20	φ12	φ30	10	30	40.6
▲ S2D 24B - 2014N	24	φ48	φ52	B1	20	φ14	φ40	10	30	62.2
▲ S2D 25B - 2014N	25	φ50	φ54	B1	20	φ14	φ40	10	30	66.6
▲ S2D 28B - 2014N	28	φ56	φ60	B1	20	φ14	φ45	10	30	85.4
▲ S2D 30B - 2018N	30	φ60	φ64	B1	20	φ18	φ45	10	30	91.4
▲ S2D 32B - 2018N	32	φ64	φ68	B1	20	φ18	φ45	10	30	102.4
▲ S2D 35B - 2018N	35	φ70	φ74	B1	20	φ18	φ50	10	30	125.5
▲ S2D 36B - 2018N	36	φ72	φ76	B1	20	φ18	φ50	10	30	131.7

▲の商品は2017年5月20日をもってカタログ商品(規格品)としての生産を中止とします。米国・EU市場の食品接触用途・規制に適合した青 POM[®] ギヤシリーズをご利用ください。Products with ▲ mark will be terminated with effective 20th May 2017. Alternative products are indicated on separate catalogue of Blue Poly Acetal gears which adapted to relevant regulations for the food industries in the US and EU markets.

許容伝達動力表 曲げ強さ (W)

Allowable transfer capability table (W) Bending Strength

商品記号 Catalogue Numbers	回転速度 (min ⁻¹) revolution/min						
	10	100	200	400	800	1,200	1,500
S2D 14B - 2010N	2.48	24.83	49.61	99.05	197.44	295.16	368.01
S2D 15B - 2010N	2.66	26.60	53.15	106.10	211.44	316.01	393.94
S2D 16B - 2012N	2.84	28.37	56.68	113.15	225.43	336.84	419.77
S2D 18B - 2012N	3.19	31.91	63.75	127.23	253.36	378.39	470.09
S2D 20B - 2012N	3.55	35.45	70.82	141.30	281.24	419.77	519.94
S2D 24B - 2014N	4.26	42.53	84.94	169.40	336.84	500.06	618.19
S2D 25B - 2014N	4.44	44.30	88.47	176.41	350.70	519.94	642.45
S2D 28B - 2014N	4.97	49.61	99.05	197.44	392.21	579.12	714.53
S2D 30B - 2018N	5.32	53.15	106.10	211.44	419.77	618.19	761.98
S2D 32B - 2018N	5.68	56.68	113.15	225.43	446.67	656.95	808.83
S2D 35B - 2018N	6.21	61.99	123.71	246.38	486.76	714.53	875.88
S2D 36B - 2018N	6.39	63.75	127.23	253.36	500.06	733.57	897.89

The above numerical values are Lewis formulas as reference only.

動力の換算式は P26 をご参照ください。

Please refer to the conversion formulas of power on page P26.

JIS B 1702-1 (ISO) 9~10 級
System of accuracy: JIS B 1702-1(ISO) class 9-10



御注文には必ず“フルネームで商品記号”を明記してください。
Please refer to the catalogue reference while ordering.

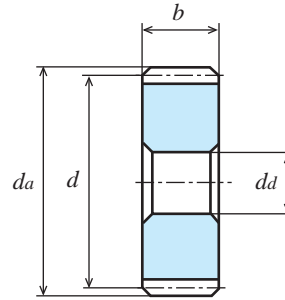

A1形
TYPE A1

ポリアセタール (黒色)

Material: Poly Acetal (Black)

単位: mm
Dimensions: mm

商品記号 Catalogue Number	歯数 Number of Teeth <i>z</i>	基準円直径 Reference Diameter <i>d</i>	歯先円直径 Tip Diameter <i>da</i>	形 Type	歯幅 Face Width <i>b</i>	穴径 Bore Diameter <i>da</i>	ハブ外径 Hub Diameter <i>dh</i>	ハブ長さ Hub Projection <i>lh</i>	全長 Overall Length <i>l</i>	重量 Weight <i>W(g)</i>
▲ S2D 40A - 2018	40	φ 80	φ 84	A1	20	φ18	-	-	20	134.6
▲ S2D 45A - 2018	45	φ 90	φ 94	A1	20	φ18	-	-	20	172.2
▲ S2D 48A - 2018	48	φ 96	φ100	A1	20	φ18	-	-	20	196.9
▲ S2D 50A - 2018	50	φ100	φ104	A1	20	φ18	-	-	20	214.3
▲ S2D 56A - 2018	56	φ112	φ116	A1	20	φ18	-	-	20	270.7
▲ S2D 60A - 2018	60	φ120	φ124	A1	20	φ18	-	-	20	311.8
▲ S2D 64A - 2018	64	φ128	φ132	A1	20	φ18	-	-	20	355.7
▲ S2D 70A - 2018	70	φ140	φ144	A1	20	φ18	-	-	20	426.9
▲ S2D 72A - 2018	72	φ144	φ148	A1	20	φ18	-	-	20	452.1
▲ S2D 80A - 2018	80	φ160	φ164	A1	20	φ18	-	-	20	559.8
▲ S2D 90A - 2018	90	φ180	φ184	A1	20	φ18	-	-	20	710.4
▲ S2D 100A - 2018	100	φ200	φ204	A1	20	φ18	-	-	20	878.8

▲の商品は2017年5月20日をもってカタログ商品(規格品)としての生産を中止とします。米国・EU市場の食品接触用途・規制に適合した青 POM® ギヤシリーズをご利用ください。Products with ▲ mark will be terminated with effective 20th May 2017. Alternative products are indicated on separate catalogue of Blue Poly Acetal gears which adapted to relevant regulations for the food industries in the US and EU markets.

許容伝達動力表 曲げ強さ (W)

Allowable transfer capability table (W) Bending Strength

商品記号 Catalogue Numbers	回転速度 (min ⁻¹) revolution/min						
	10	100	200	400	800	1,200	1,500
S2D 40A - 2018	7.10	70.82	141.30	281.24	552.90	808.83	984.27
S2D 45A - 2018	7.98	79.65	158.87	316.01	618.19	897.89	1,088.49
S2D 48A - 2018	8.52	84.94	169.40	336.84	656.95	950.04	1,148.58
S2D 50A - 2018	8.87	88.47	176.41	350.70	682.63	984.27	1,184.49
S2D 56A - 2018	9.94	99.05	197.44	392.21	758.83	1,084.40	1,286.48
S2D 60A - 2018	10.64	106.10	211.44	419.77	808.83	1,148.58	1,349.70
S2D 64A - 2018	11.35	113.15	225.43	446.67	856.66	1,205.57	-
S2D 70A - 2018	12.42	123.71	246.38	486.76	926.98	1,286.48	-
S2D 72A - 2018	12.77	127.23	253.36	500.06	950.04	1,312.23	-
S2D 80A - 2018	14.19	141.30	281.24	552.90	1,040.38	-	-
S2D 90A - 2018	15.96	158.87	316.01	618.19	1,148.58	-	-
S2D 100A - 2018	17.74	176.41	350.70	682.63	1,242.21	-	-

The above numerical values are Lewis formulas as reference only.

動力の換算式は P26 をご参照ください。

Please refer to the conversion formulas of power on page P26.

ステンレス平歯車

SPUR GEARS

モジュール
MODULE

2

圧力角 20° (並歯)
20° PRESSURE ANGLE FULL DEPTH TOOTH

JIS B 1702-1 (ISO) 9級
System of accuracy : JIS B 1702-1(ISO) class 9



New 仕様変更 省スペース・軽量化。
Specification change Space-saving and weight saving.

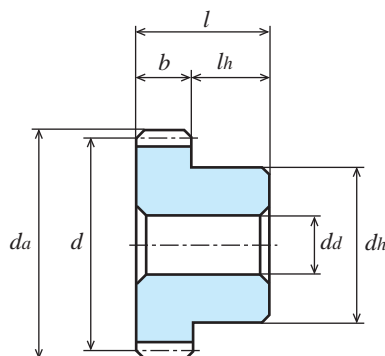

B1形
TYPE B1

SUS304 ステンレス鋼棒 (JIS G 4303)

Material : Stainless Steel SUS304 (JIS G 4303)

単位 : mm
Dimensions : mm

商品記号 Catalogue Number	歯数 Number of Teeth z	基準円直径 Reference Diameter d	歯先円直径 Tip Diameter da	形 Type	歯幅 Face Width b	穴径 Bore Diameter $da(H8)$	ハブ外径 Hub Diameter dh	ハブ長さ Hub Projection lh	全長 Overall Length l	重量 Weight $W(g)$
S2SU 14B - 1410N	14	φ28	φ32	B1	14	φ10	φ20	10	24	78.3
S2SU 15B - 1410N	15	φ30	φ34	B1	14	φ10	φ22	10	24	93.7
S2SU 18B - 1412N	18	φ36	φ40	B1	14	φ12	φ28	10	24	14.0
S2SU 20B - 1412N	20	φ40	φ44	B1	14	φ12	φ30	10	24	174.0
S2SU 24B - 1414N	24	φ48	φ52	B1	14	φ14	φ36	10	24	252.3
S2SU 25B - 1414N	25	φ50	φ54	B1	14	φ14	φ36	10	24	269.4
S2SU 30B - 1414N	30	φ60	φ64	B1	14	φ14	φ40	10	24	384.3
S2SU 32B - 1214N	32	φ64	φ68	B1	12	φ14	φ45	10	22	405.4
S2SU 35B - 1214N	35	φ70	φ74	B1	12	φ14	φ45	10	22	465.5
S2SU 36B - 1214N	36	φ72	φ76	B1	12	φ14	φ45	10	22	486.7
S2SU 40B - 1214N	40	φ80	φ84	B1	12	φ14	φ50	10	22	607.2
S2SU 45B - 1214N	45	φ90	φ94	B1	12	φ14	φ60	10	22	802.7

許容伝達動力表 曲げ強さ (kW)

Allowable transfer capability table (W) Bending Strength

商品記号 Catalogue Numbers	回転速度 (min ⁻¹) revolution/min						
	10	100	200	400	800	1,200	1,500
S2SU 14B - 1410N	0.012	0.124	0.248	0.496	0.966	1.335	1.576
S2SU 15B - 1410N	0.014	0.139	0.278	0.556	1.070	1.471	1.731
S2SU 18B - 1412N	0.019	0.185	0.371	0.741	1.377	1.870	2.181
S2SU 20B - 1412N	0.022	0.218	0.435	0.870	1.580	2.128	2.497
S2SU 24B - 1414N	0.028	0.284	0.567	1.134	1.970	2.616	3.178
S2SU 25B - 1414N	0.030	0.301	0.601	1.194	2.065	2.759	3.348
S2SU 30B - 1414N	0.039	0.386	0.773	1.488	2.519	3.463	4.182
S2SU 32B - 1214N	0.036	0.361	0.722	1.374	2.307	3.207	3.866
S2SU 35B - 1214N	0.041	0.406	0.813	1.520	2.521	3.560	4.304
S2SU 36B - 1214N	0.042	0.422	0.843	1.567	2.593	3.677	4.449
S2SU 40B - 1214N	0.048	0.483	0.966	1.754	2.933	4.138	5.023
S2SU 45B - 1214N	0.056	0.560	1.121	1.979	3.349	4.729	5.722

The above numerical values are equivalent to JGMA formulas as reference only.

動力の換算式は P26 をご参照ください。

Please refer to the conversion formulas of power on page P26.

ステンレス平歯車

SPUR GEARS

モジュール
MODULE

2

圧力角 20° (並歯)
20° PRESSURE ANGLE FULL DEPTH TOOTH

JIS B 1702-1 (ISO) 9 級
System of accuracy : JIS B 1702-1(ISO) class 9



御注文には必ず“フルネームで商品記号”を明記してください。
Please refer to the catalogue reference while ordering.

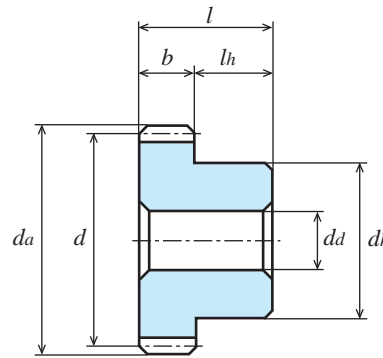

B1形
TYPE B1

SUS304 ステンレス鋼棒 (JIS G 4303)

Material : Stainless Steel SUS304 (JIS G 4303)

単位 : mm
Dimensions : mm

商品記号 Catalogue Number	歯数 Number of Teeth <i>z</i>	基準円直径 Reference Diameter <i>d</i>	歯先円直径 Tip Diameter <i>da</i>	形 Type	歯幅 Face Width <i>b</i>	穴径 Bore Diameter <i>da</i> (H8)	ハブ外径 Hub Diameter <i>dh</i>	ハブ長さ Hub Projection <i>lh</i>	全長 Overall Length <i>l</i>	重量 Weight <i>W</i> (kg)
S2SU 48B - 1215N	48	φ 96	φ100	B1	12	φ15	φ60	10	22	0.88
S2SU 50B - 1215N	50	φ100	φ104	B1	12	φ15	φ60	10	22	0.94
S2SU 55B - 1215N	55	φ110	φ114	B1	12	φ15	φ60	10	22	1.10
S2SU 60B - 1215N	60	φ120	φ124	B1	12	φ15	φ60	10	22	1.27
S2SU 64B - 1215N	64	φ128	φ132	B1	12	φ15	φ60	10	22	1.42
S2SU 72B - 1216N	72	φ144	φ148	B1	12	φ16	φ60	10	22	1.74
S2SU 80B - 1216N	80	φ160	φ164	B1	12	φ16	φ60	10	22	2.10
S2SU 90B - 1216N	90	φ180	φ184	B1	12	φ16	φ60	10	22	2.61
S2SU 100B - 1216N	100	φ200	φ204	B1	12	φ16	φ60	10	22	3.18

許容伝達動力表 曲げ強さ (kW)

Allowable transfer capability table (kW) Bending Strength

商品記号 Catalogue Numbers	回転速度 (min ⁻¹) revolution/min						
	10	100	200	400	800	1,200	1,500
S2SU 48B - 1215N	0.060	0.61	1.21	2.11	3.60	5.08	6.13
S2SU 50B - 1215N	0.063	0.64	1.27	2.19	3.76	5.31	6.41
S2SU 55B - 1215N	0.071	0.72	1.40	2.40	4.16	5.88	7.17
S2SU 60B - 1215N	0.079	0.80	1.53	2.60	4.55	6.44	7.97
S2SU 64B - 1215N	0.086	0.86	1.64	2.75	4.88	6.88	-
S2SU 72B - 1216N	0.098	0.99	1.84	3.04	5.51	7.91	-
S2SU 80B - 1216N	0.112	1.12	2.03	3.39	6.14	-	-
S2SU 90B - 1216N	0.128	1.28	2.26	3.82	6.89	-	-
S2SU 100B - 1216N	0.143	1.43	2.47	4.24	7.68	-	-

The above numerical values are equivalent to JGMA formulas as reference only.

動力の換算式は P26 をご参照ください。

Please refer to the conversion formulas of power on page P26.

目次
CONTENTS

インフォメーション
INFORMATION

ギヤボックス
GEAR BOXES

ノーバッキングスピリットギヤ
ANTI BACKLASH SPUR GEARS

歯研平歯車
GROUND SPUR GEARS

平歯車
SPUR GEARS

内歯車
INTERNAL GEARS

歯研ラック
GROUND RACKS

ラック
RACKS

へリカル・スクリューギヤ
HELICAL GEARS AND SCREW GEARS

ウォーム・ウォームギヤ
WORMS AND WORM GEARS

かさ歯車
BEVEL GEARS

スプロケット
SPROCKETS

技術資料
REFERENCE DATA

平歯車 SPUR GEARS

モジュール
MODULE

2

圧力角 20° (並歯) 歯数 8 ~ 14

20° PRESSURE ANGLE FULL DEPTH TOOTH Z 8 to Z 14

JIS B 1702-1 (ISO) 8~9 級
System of accuracy : JIS B 1702-1(ISO) class 8-9



仕様変更 省スペース・軽量化。

Specification change Space-saving and weight saving.

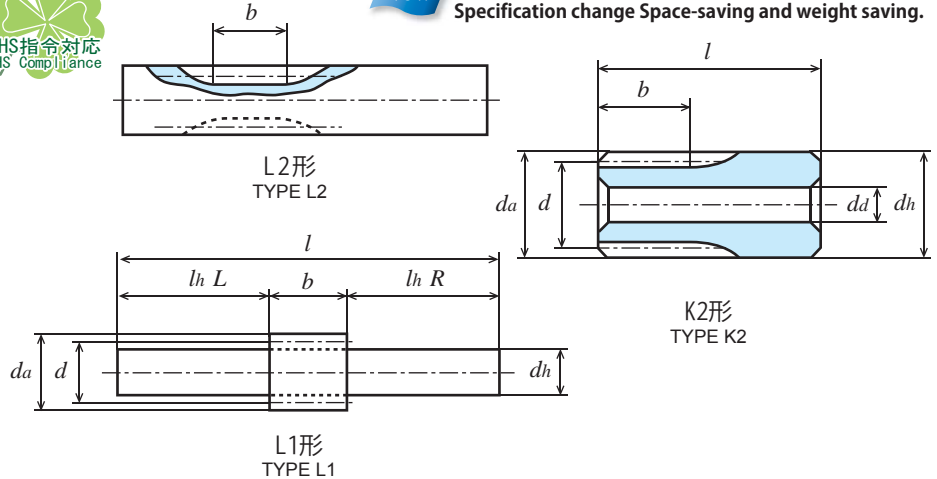

S45C 機械構造用炭素鋼 (JIS G 4051) *印を付した商品は転位歯車です。転位係数 x は 0.5 です。
Material : Carbon Steel (ISO C45) * mark has been profile shifted gears. (Rack shift coefficient $x = 0.5$)

単位 : mm
Dimensions : mm

商品記号 Catalogue Number	歯数 Number of Teeth z	基準円直径 Reference Diameter d	歯先円直径 Tip Diameter d_a	形 Type	歯幅 Face Width b	穴径 Bore Diameter $d_a(H7)$	ハブ外径 Hub Diameter d_h	ハブ長さ Hub Projection l_h	全長 Overall Length l	重量 Weight $W(g)$
S2S 8L - 2212	8	*	$\phi 21.28$	L1	22	-	$\phi 12(h9)$	L32 R64	118	129.2
S2S 8L - 2221F	8	*	$\phi 21.28$	L2	22	-	$\phi 21.28$	L32 R64	118	312.0
S2S 10L - 2216	10	*	$\phi 25.33$	L1	22	-	$\phi 16(h9)$	L32 R64	118	217.2
S2S 10L - 2225F	10	*	$\phi 25.33$	L2	22	-	$\phi 25.33$	L32 R64	118	445.4
S2S 12K - 2210	12	$\phi 24$	$\phi 28$	K2	22	$\phi 10(H8)$	$\phi 28$	28	50	182.6
S2S 13K - 2210F	13	$\phi 26$	$\phi 30$	K2	22	$\phi 10(H8)$	$\phi 30$	28	50	216.2
S2S 14A - 1410	14	$\phi 28$	$\phi 32$	A1	14	$\phi 10$	-	-	14	59.0
S2S 14A - 2010	14	$\phi 28$	$\phi 32$	A1	20	$\phi 10$	-	-	20	84.3
S2S 14A - 2210	14	$\phi 28$	$\phi 32$	A1	22	$\phi 10$	-	-	22	92.8
S2S 14B - 1410N	14	$\phi 28$	$\phi 32$	B1	14	$\phi 10$	$\phi 22$	10	24	82.8
S2S 14B - 2010N	14	$\phi 28$	$\phi 32$	B1	20	$\phi 10(H8)$	$\phi 22$	10	30	108.1
S2S 14B - 2210N	14	$\phi 28$	$\phi 32$	B1	22	$\phi 10(H8)$	$\phi 22$	10	32	116.5

許容伝達動力表 曲げ強さ (kW)

Allowable transfer capability table (kW) Bending Strength

歯数 z	歯幅 b	回転速度 (min ⁻¹) revolution/min							回転速度 (min ⁻¹) revolution/min
		10	100	200	400	800	1,200	1,500	
8	22	0.023	0.235	0.471	0.942	1.885	2.785	3.345	100
10	22	0.032	0.325	0.650	1.300	2.600	3.702	4.414	22.44
12	22	0.029	0.298	0.597	1.195	2.388	3.331	3.956	31.03
13	22	0.034	0.343	0.687	1.374	2.712	3.764	4.456	28.45
14	14	0.024	0.247	0.495	0.991	1.932	2.670	3.151	32.75
14	20	0.035	0.354	0.708	1.416	2.761	3.814	4.501	23.58
14	22	0.038	0.389	0.779	1.558	3.037	4.196	4.951	33.80
									37.14

The above numerical values are equivalent to JGMA formulas as reference only.

動力の換算式は P26 をご参照ください。Please refer to the conversion fomulas of power on page P26.

JIS B 1702-1 (ISO) 8 級
System of accuracy : JIS B 1702-1(ISO) class 8



御注文には必ず“フルネームで商品記号”を明記してください。
Please refer to the catalogue reference while ordering.

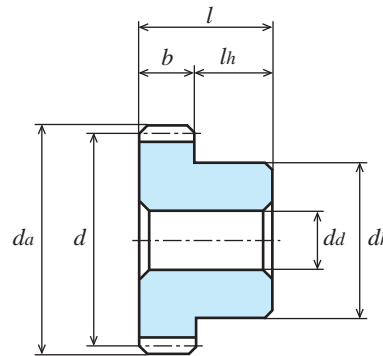

B1形
TYPE B1

S45C 機械構造用炭素鋼 (JIS G 4051) Material : Carbon Steel (ISO C45)

単位 : mm
Dimensions : mm

商品記号 Catalogue Number	歯数 Number of Teeth z	基準円直径 Reference Diameter d	歯先円直径 Tip Diameter da	形 Type	歯幅 Face Width b	穴径 Bore Diameter da(H7)	ハブ外径 Hub Diameter dh	ハブ長さ Hub Projection lh	全長 Overall Length l	キミぞ Key Way b ₂ × t ₂	重量 Weight W(g)
S2S 15A - 1410	15	φ30	φ34	A1	14	φ10	-	-	14	-	69.5
S2S 15A - 2010	15	φ30	φ34	A1	20	φ10	-	-	20	-	98.7
S2S 15A - 2210	15	φ30	φ34	A1	22	φ10	-	-	22	-	108.5
S2S 15B - 1410N	15	φ30	φ34	B1	14	φ10	φ24	10	24	-	98.5
S2S 15B - 2010N	15	φ30	φ34	B1	20	φ10(H8)	φ24	10	30	-	128.1
S2S 15B - 2210N	15	φ30	φ34	B1	22	φ10(H8)	φ24	10	32	-	138.0
S2S 16A - 1412	16	φ32	φ36	A1	14	φ12	-	-	14	-	76.0
S2S 16A - 2012	16	φ32	φ36	A1	20	φ12	-	-	20	-	108.5
S2S 16A - 2212	16	φ32	φ36	A1	22	φ12	-	-	22	-	119.4
S2S 16B - 1412N	16	φ32	φ36	B1	14	φ12	φ26	10	24	-	108.8
S2S 16B - 2012N	16	φ32	φ36	B1	20	φ12	φ26	10	30	-	141.4
S2S 16B - 2212N	16	φ32	φ36	B1	22	φ12	φ26	10	32	-	152.3
S2S 17B - 1412	17	φ34	φ38	B1	14	φ12	φ28	10	24	-	126.9
S2S 17B - 2212	17	φ34	φ38	B1	22	φ12	φ28	10	32	-	176.8

許容伝達動力表 曲げ強さ (kW)

Allowable transfer capability table (kW) Bending Strength

歯数 z	歯幅 b	回転速度 (min ⁻¹) revolution/min							回転速度 (min ⁻¹) revolution/min
		10	100	200	400	800	1,200	1,500	
15	14	0.027	0.277	0.555	1.111	2.139	2.942	3.462	100
15	20	0.039	0.396	0.793	1.587	3.056	4.203	4.946	100
15	22	0.043	0.436	0.873	1.746	3.362	4.624	5.440	100
16	14	0.030	0.308	0.616	1.233	2.346	3.212	3.768	100
16	20	0.044	0.440	0.880	1.761	3.352	4.589	5.383	100
16	22	0.048	0.484	0.968	1.937	3.687	5.047	5.922	100
17	14	0.034	0.339	0.678	1.357	2.551	3.478	4.069	100
17	22	0.053	0.533	1.066	2.132	4.009	5.465	6.393	100

KG 規格は“並幅” (軽荷重用) と“広幅” (重荷重用) があります。ご用途に応じてお選び下さい。

KG STOCK GEARS has Wide-face width for Heavy load, and Standard-face width for Light load.

You are able to multiple choices for your suitable design from our wide range.

The above numerical values are equivalent to JGMA formulas as reference only.

動力の換算式は P26 をご参照ください。Please refer to the conversion fomulas of power on page P26.

平歯車 SPUR GEARS

モジュール
MODULE

2

圧力角 20° (並歯) 歯数 18 19

20° PRESSURE ANGLE FULL DEPTH TOOTH Z 18 to Z 19

JIS B 1702-1 (ISO) 8 級
System of accuracy : JIS B 1702-1(ISO) class 8



仕様変更 省スペース・軽量化、締結加工不要。

Specification change Space-saving and weight saving.
Additional machining on tightening is not necessary.

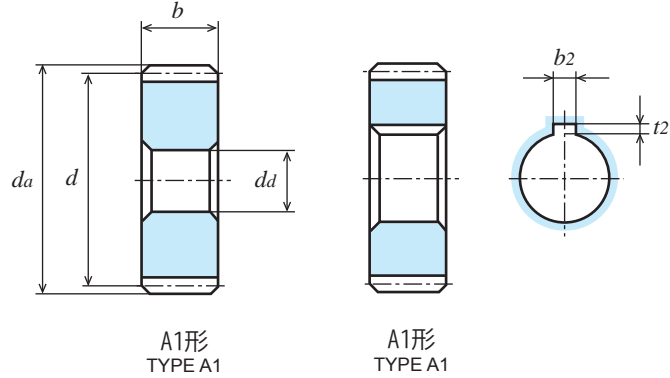

S45C 機械構造用炭素鋼 (JIS G 4051) Material : Carbon Steel (ISO C45)

単位 : mm
Dimensions : mm

商品記号 Catalogue Number	歯数 Number of Teeth <i>z</i>	基準円直径 Reference Diameter <i>d</i>	歯先円直径 Outside Diameter <i>da</i>	形 Type	歯幅 Face Width <i>b</i>	穴径 Bore Diameter <i>da(H7)</i>	ハブ外径 Hub Diameter <i>dh</i>	ハブ長さ Hub Projection <i>lh</i>	全長 Overall Length <i>l</i>	キミぞ Key Way <i>b2 × t2</i>	ねじ Set Screw		リム内径 Dimension of Rim <i>di</i>	ウェブ厚さ Thickness of Web <i>bw</i>	重量 Weight <i>W(g)</i>
											<i>M</i>	<i>ls</i>			
S2S 18A - 1212F	18	φ36	φ40	A1	12	φ12	-	-	12	-	-	-	-	-	85.2
S2S 18A - 1412F	18	φ36	φ40	A1	14	φ12	-	-	14	-	-	-	-	-	99.4
S2S 18A = 1415	18	φ36	φ40	A1	14	φ15	-	-	14	5 × 2.3	-	-	-	-	93.7
S2S 18A - 2012F	18	φ36	φ40	A1	20	φ12	-	-	20	-	-	-	-	-	142.1
S2S 18A - 2212F	18	φ36	φ40	A1	22	φ12	-	-	22	-	-	-	-	-	156.3
S2S 18A = 2215	18	φ36	φ40	A1	22	φ15	-	-	22	5 × 2.3	-	-	-	-	143.3
S2S 18B - 1212	18	φ36	φ40	B1	12	φ12	φ29	10	22	-	-	-	-	-	128.3
S2S 18B - 1412	18	φ36	φ40	B1	14	φ12	φ30	10	24	-	-	-	-	-	146.1
S2S 18B # 1415	18	φ36	φ40	B1	14	φ15	φ30	10	24	5 × 2.3	M4	5	-	-	131.6
S2S 18B - 2012N	18	φ36	φ40	B1	20	φ12	φ30	10	30	-	-	-	-	-	188.8
S2S 18B - 2212	18	φ36	φ40	B1	22	φ12	φ30	10	32	-	-	-	-	-	203.0
S2S 18B # 2215	18	φ36	φ40	B1	22	φ15	φ30	10	32	5 × 2.3	M4	5	-	-	183.7
S2S 19B - 1412	19	φ38	φ42	B1	14	φ12	φ32	10	24	-	-	-	-	-	166.6
S2S 19B - 2212	19	φ38	φ42	B1	22	φ12	φ32	10	32	-	-	-	-	-	230.7

【=】 (イコール) にはキー材が付いております。 [=]: Gear with key way / with key

【#】 (シャープ) にはキー材とセットスクリューが付いております。 [#]: Gear with key way and threaded hole / with key and screw.

許容伝達動力表 曲げ強さ (kW)

T (N · m)

Allowable transfer capability table (kW) Bending Strength

歯数 <i>z</i>	歯幅 <i>b</i>	回転速度 (min ⁻¹) revolution/min							回転速度 (min ⁻¹) revolution/min
		10	100	200	400	800	1,200	1,500	
18	12	0.031	0.317	0.635	1.270	2.361	3.205	3.739	100
18	14	0.037	0.370	0.741	1.482	2.754	3.739	4.362	30.27
18	20	0.052	0.529	1.058	2.117	3.935	5.341	6.232	35.33
18	22	0.058	0.582	1.164	2.329	4.328	5.875	6.855	50.51
19	14	0.040	0.403	0.806	1.611	2.960	4.001	4.656	55.57
19	22	0.063	0.633	1.266	2.532	4.651	6.287	7.317	38.48
									60.44

The above numerical values are equivalent to JGMA formulas as reference only.

動力の換算式は P26 をご参照ください。 Please refer to the conversion fomulas of power on page P26.

平歯車

SPUR GEARS

モジュール
MODULE

2

圧力角 20° (並歯) 歯数 20

20° PRESSURE ANGLE FULL DEPTH TOOTH Z 20

JIS B 1702-1 (ISO) 8級 (高周波焼入品: 9級)
System of accuracy: JIS B 1702-1(ISO) class 8
(Induction hardened products: class 9)



御注文には必ず“フルネームで商品記号”を明記してください。

Please refer to the catalogue reference while ordering.

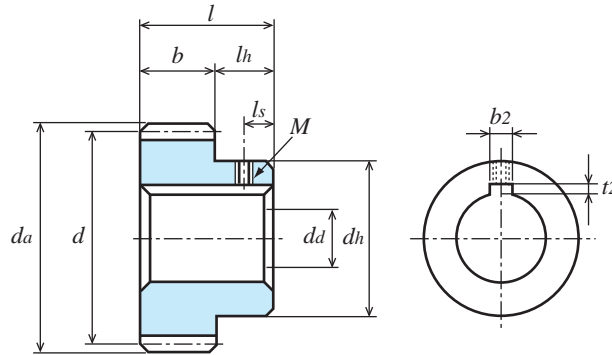

B1形
TYPE B1

S45C 機械構造用炭素鋼 (JIS G 4051)

Material: Carbon Steel (ISO C45)

単位: mm
Dimensions: mm

商品記号 Catalogue Number	歯数 Number of Teeth z	基準円直径 Reference Diameter d	歯先円直径 Outside Diameter da	形 Type	歯幅 Face Width b	穴径 Bore Diameter da(H7)	ハブ外径 Hub Diameter dh	ハブ長さ Hub Projection lh	全長 Overall Length l	キミぞ Key Way b2 × t2	ねじ Set Screw		リム内径 Dimension of Rim di	ウェブ厚さ Thickness of Web bw	重量 Weight W(g)
											M	ls			
S2S 20A - 1212F	20	φ40	φ44	A1	12	φ12	-	-	12	-	-	-	-	107.7	
S2S 20A - 1412F	20	φ40	φ44	A1	14	φ12	-	-	14	-	-	-	-	125.7	
S2S 20A = 1415	20	φ40	φ44	A1	14	φ15	-	-	14	5 × 2.3	-	-	-	117.4	
S2S 20A = 1416	20	φ40	φ44	A1	14	φ16	-	-	14	5 × 2.3	-	-	-	114.7	
S2S 20A - 2012F	20	φ40	φ44	A1	20	φ12	-	-	20	-	-	-	-	179.5	
S2S 20A - 2212F	20	φ40	φ44	A1	22	φ12	-	-	22	-	-	-	-	197.5	
S2S 20A = 2215	20	φ40	φ44	A1	22	φ15	-	-	22	5 × 2.3	-	-	-	184.5	
S2S 20A = 2220	20	φ40	φ44	A1	22	φ20	-	-	22	6 × 2.8	-	-	-	159.9	
S2S 20B - 1212	20	φ40	φ44	B1	12	φ12	φ33	10	22	-	-	-	-	162.1	
S2S 20B - 1412	20	φ40	φ44	B1	14	φ12	φ32	10	24	-	-	-	-	180.0	
S2S 20B # 1415	20	φ40	φ44	B1	14	φ15	φ32	10	24	5 × 2.3	M4	5	-	165.4	
S2S 20B # 1416	20	φ40	φ44	B1	14	φ16	φ32	10	24	5 × 2.3	M4	5	-	160.8	
● S2S 20BF - 2008	20	φ40	φ44	B1	20	φ 8(H8)	φ34	20	40	-	-	-	-	321.1	
● S2S 20B - 2008H	20	φ40	φ44	B1	20	φ 8(H※)	φ34	20	40	-	-	-	-	321.1	
S2S 20B - 2012N	20	φ40	φ44	B1	20	φ12	φ34	10	30	-	-	-	-	242.1	
S2S 20B - 2212	20	φ40	φ44	B1	22	φ12	φ34	10	32	-	-	-	-	260.1	
S2S 20B # 2215	20	φ40	φ44	B1	22	φ15	φ34	10	32	5 × 2.3	M4	5	-	240.6	
S2S 20B # 2220	20	φ40	φ44	B1	22	φ20	φ34	10	32	6 × 2.8	M4	5	-	204.9	

●の商品は新商品です。Products with ● marks are new item.

【=】(イコール)にはキー材が付いております。【=】: Gear with key way / with key

【#】(シャープ)にはキー材とセットスクリューが付いております。【#】: Gear with key way and threaded hole / with key and screw.

許容伝達動力表 曲げ強さ (kW)

Allowable transfer capability table (kW) Bending Strength

歯数 z	歯幅 b	焼入 H	回転速度 (min ⁻¹) revolution/min						
			10	100	200	400	800	1,200	1,500
20	12	-	0.037	0.372	0.745	1.491	2.709	3.647	4.280
20	14	-	0.043	0.435	0.870	1.740	3.160	4.255	4.993
20	20	-	0.063	0.630	1.250	2.500	4.550	6.120	7.190
20	20	○	0.066	0.664	1.328	2.655	4.863	6.603	7.784
20	22	-	0.068	0.683	1.367	2.735	4.966	6.687	7.846

The above references are JGMA standard.

動力の換算式は P26 をご参照ください。Please refer to the conversion formulas of power on page P26.

許容伝達動力表 歯面強さ (kW)

Allowable transfer capability table (kW) Surface Durability

回転速度 (min ⁻¹) revolution/min						
10	100	200	400	800	1,200	1,500
-	-	-	-	-	-	-
-	-	-	-	-	-	-
0.003	0.030	0.060	0.110	0.210	0.290	0.340
0.012	0.137	0.283	0.583	1.101	1.522	1.812
-	-	-	-	-	-	-

目次
CONTENTS

インフォメーション
INFORMATION

ギヤボックス
GEAR BOXES

ノーバッキングギヤ
ANTI BACKLASH SPUR GEARS

歯研削歯車
GROUND SPUR GEARS

歯研削歯車
SPUR GEARS

内歯車
INTERNAL GEARS

歯研削ラック
GROUND RACKS

ラック
RACKS

ハニカムギヤ
HELIICAL GEARS AND SCREW GEARS

かさ歯車
BEVEL GEARS

スプロケット
SPROCKETS

技術資料
REFERENCE DATA

平歯車

SPUR GEARS

モジュール
MODULE

2

圧力角 20° (並歯) 歯数 21 ~ 23
20° PRESSURE ANGLE FULL DEPTH TOOTH Z 21 to Z 23

JIS B 1702-1 (ISO) 8級
System of accuracy : JIS B 1702-1(ISO) class 8



New 仕様変更 省スペース・軽量化。
Specification change Space-saving and weight saving.

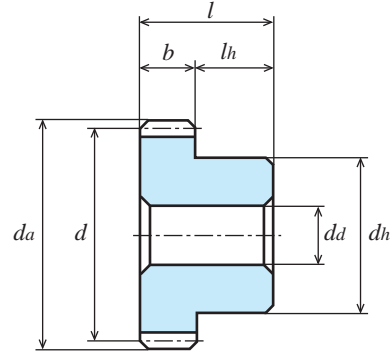

B1形
TYPE B1

S45C 機械構造用炭素鋼 (JIS G 4051) Material : Carbon Steel (ISO C45)

単位 : mm
Dimensions : mm

商品記号 Catalogue Number	歯数 Number of Teeth <i>z</i>	基準円直径 Reference Diameter <i>d</i>	歯先円直径 Tip Diameter <i>da</i>	形 Type	歯幅 Face Width <i>b</i>	穴径 Bore Diameter <i>da(H7)</i>	ハブ外径 Hub Diameter <i>dh</i>	ハブ長さ Hub Projection <i>lh</i>	全長 Overall Length <i>l</i>	キーマみぞ Key Way <i>b₂ × t₂</i>	重量 Weight <i>W(g)</i>
S2S 21B - 1412	21	φ42	φ46	B1	14	φ12	φ36	10	24	-	211.0
S2S 21B - 2212	21	φ42	φ46	B1	22	φ12	φ36	10	32	-	290.9
S2S 22B - 1412	22	φ44	φ48	B1	14	φ12	φ38	10	24	-	235.0
S2S 22B - 2212	22	φ44	φ48	B1	22	φ12	φ38	10	32	-	323.4
S2S 23B - 1412	23	φ46	φ50	B1	14	φ12	φ40	10	24	-	260.2
S2S 23B - 2212	23	φ46	φ50	B1	22	φ12	φ40	10	32	-	357.5

許容伝達動力表 曲げ強さ (kW)

Allowable transfer capability table (kW) Bending Strength

歯数 <i>z</i>	歯幅 <i>b</i>	回転速度 (min ⁻¹) revolution/min							回転速度 (min ⁻¹) revolution/min
		10	100	200	400	800	1,200	1,500	100
21	14	0.046	0.47	0.94	1.87	3.36	4.50	5.33	44.88
21	22	0.073	0.73	1.47	2.94	5.28	7.08	8.38	69.71
22	14	0.050	0.50	1.00	2.00	3.56	4.75	5.68	47.74
22	22	0.078	0.79	1.57	3.15	5.59	7.47	8.92	75.44
23	14	0.053	0.53	1.07	2.13	3.75	4.99	6.02	50.61
23	22	0.083	0.84	1.68	3.36	5.89	7.84	9.46	80.21

The above numerical values are equivalent to JGMA formulas as reference only.

動力の換算式は P26 をご参照ください。Please refer to the conversion fomulas of power on page P26.

平歯車

SPUR GEARS

モジュール
MODULE

2

圧力角 20° (並歯) 歯数 24

20° PRESSURE ANGLE FULL DEPTH TOOTH Z 24

JIS B 1702-1 (ISO) 8 級
System of accuracy : JIS B 1702-1(ISO) class 8



御注文には必ず“フルネームで商品記号”を明記してください。

Please refer to the catalogue reference while ordering.

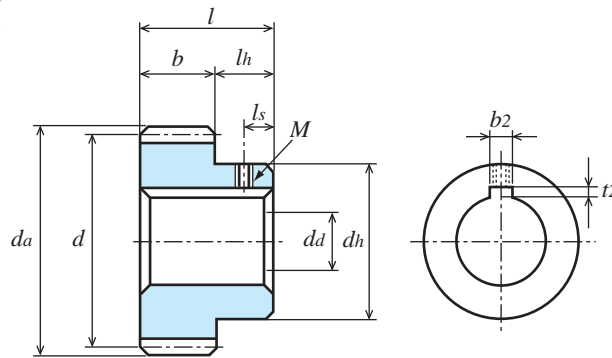

B1形
TYPE B1

S45C 機械構造用炭素鋼 (JIS G 4051)

Material : Carbon Steel (ISO C45)

単位 : mm
Dimensions : mm

商品記号 Catalogue Number	歯数 Number of Teeth z	基準円直径 Reference Diameter d	歯先円直径 Outside Diameter da	形 Type	歯幅 Face Width b	穴径 Bore Diameter da(H7)	ハブ外径 Hub Diameter dh	ハブ長さ Hub Projection lh	全長 Overall Length l	キミぞ Key Way b2 × t2	ねじ Set Screw		リム内径 Dimension of Rim di	ウエブ厚さ Thickness of Web bw	重量 Weight W(g)
											M	ls			
S2S 24A - 1214F	24	φ48	φ52	A1	12	φ14	-	-	12	-	-	-	-	156.0	
S2S 24A - 1412F	24	φ48	φ52	A1	14	φ12	-	-	14	-	-	-	-	186.4	
S2S 24A = 1415	24	φ48	φ52	A1	14	φ15	-	-	14	5 × 2.3	-	-	-	178.2	
S2S 24A = 1416	24	φ48	φ52	A1	14	φ16	-	-	14	5 × 2.3	-	-	-	175.5	
S2S 24A - 2014F	24	φ48	φ52	A1	20	φ14	-	-	20	-	-	-	-	259.9	
S2S 24A - 2214F	24	φ48	φ52	A1	22	φ14	-	-	22	-	-	-	-	285.9	
S2S 24A = 2215	24	φ48	φ52	A1	22	φ15	-	-	22	5 × 2.3	-	-	-	280.0	
S2S 24A = 2220	24	φ48	φ52	A1	22	φ20	-	-	22	6 × 2.8	-	-	-	255.4	
S2S 24B - 1214	24	φ48	φ52	B1	12	φ14	φ40	10	22	-	-	-	-	207.1	
S2S 24B - 1414	24	φ48	φ52	B1	14	φ14	φ32	10	24	-	-	-	-	233.2	
S2S 24B # 1415	24	φ48	φ52	B1	14	φ15	φ32	10	24	5 × 2.3	M4	5	-	226.2	
S2S 24B # 1416	24	φ48	φ52	B1	14	φ16	φ32	10	24	5 × 2.3	M4	5	-	221.6	
S2S 24B - 2014N	24	φ48	φ52	B1	20	φ14	φ42	10	30	-	-	-	-	356.8	
S2S 24B - 2214	24	φ48	φ52	B1	22	φ14	φ40	10	32	-	-	-	-	372.7	
S2S 24B # 2215	24	φ48	φ52	B1	22	φ15	φ40	10	32	5 × 2.3	M4	5	-	363.3	
S2S 24B # 2220	24	φ48	φ52	B1	22	φ20	φ40	10	32	6 × 2.8	M5	5	-	327.3	

【=】(イコール)にはキー材が付いております。【=】: Gear with key way / with key

【#】(シャープ)にはキー材とセットスクリューが付いております。【#】: Gear with key way and threaded hole / with key and screw.

許容伝達動力表 曲げ強さ (kW)

Allowable transfer capability table (kW) Bending Strength

歯数 z	歯幅 b	回転速度 (min ⁻¹) revolution/min							回転速度 (min ⁻¹) revolution/min
		10	100	200	400	800	1,200	1,500	
24	12	0.048	0.49	0.97	1.94	3.377	4.49	5.45	100
24	14	0.056	0.57	1.14	2.27	3.940	5.23	6.36	100
24	20	0.081	0.81	1.62	3.24	5.63	7.48	9.08	100
24	22	0.089	0.89	1.78	3.56	6.19	8.22	9.99	100

KG 規格は“並幅”(軽荷重用)と“広幅”(重荷重用)があります。ご用途に応じてお選び下さい。

KG STOCK GEARS has Wide-face width for Heavy load, and Standard-face width for Light load.

You are able to multiple choices for your suitable design from our wide range.

The above numerical values are equivalent to JGMA formulas as reference only.

動力の換算式は P26 をご参照ください。Please refer to the conversion fomulas of power on page P26.

目次

インフォメーション

ギヤボックス

ノーバックラッシュギヤ

歯研削歯車

平歯車

内歯車

歯研削ラック

ラック

ハブ・スクリューギヤ

ワーム・ワームギヤ

かさ歯車

スプロケット

技術資料

平歯車

SPUR GEARS

モジュール
MODULE

2

圧力角 20° (並歯) 歯数 25 ~ 26

20° PRESSURE ANGLE FULL DEPTH TOOTH Z 25 to Z 26

JIS B 1702-1 (ISO) 8級 (高周波焼入品: 9級)
System of accuracy: JIS B 1702-1(ISO) class 8
(Induction hardened products: class 9)



仕様変更 省スペース・軽量化、締結加工不要。

Specification change Space-saving and weight saving.
Additional machining on tightening is not necessary.

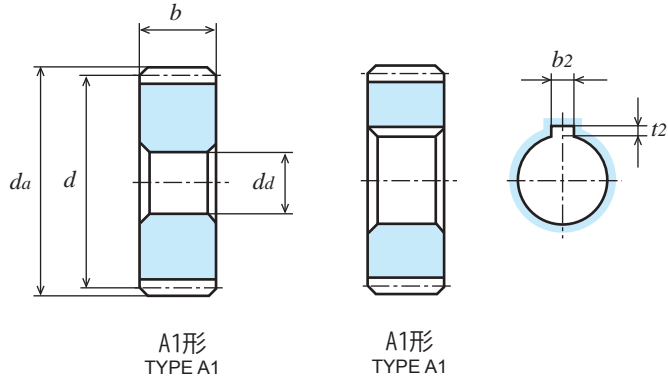

A1形
TYPE A1

A1形
TYPE A1

S45C 機械構造用炭素鋼 (JIS G 4051)

Material: Carbon Steel (ISO C45)

単位: mm
Dimensions: mm

商品記号 Catalogue Number	歯数 Number of Teeth z	基準円直径 Reference Diameter d	歯先円直径 Outside Diameter da	形 Type	歯幅 Face Width b	穴径 Bore Diameter da(H7)	ハブ外径 Hub Diameter dh	ハブ長さ Hub Projection lh	全長 Overall Length l	キミぞ Key Way b2 × t2	ねじ Set Screw		リム内径 Dimension of Rim di	ウェブ厚さ Thickness of Web bw	重量 Weight W(g)
											M	ls			
S2S 25A - 1214F	25	φ50	φ54	A1	12	φ14	-	-	12	-	-	-	-	-	170.5
S2S 25A - 1414F	25	φ50	φ54	A1	14	φ14	-	-	14	-	-	-	-	-	198.9
S2S 25A = 1415	25	φ50	φ54	A1	14	φ15	-	-	14	5 × 2.3	-	-	-	-	195.1
S2S 25A = 1416	25	φ50	φ54	A1	14	φ16	-	-	14	5 × 2.3	-	-	-	-	192.4
S2S 25A - 2014F	25	φ50	φ54	A1	20	φ14	-	-	20	-	-	-	-	-	284.1
S2S 25A - 2214F	25	φ50	φ54	A1	22	φ14	-	-	22	-	-	-	-	-	312.5
S2S 25A = 2215	25	φ50	φ54	A1	22	φ15	-	-	22	5 × 2.3	-	-	-	-	306.6
S2S 25A = 2220	25	φ50	φ54	A1	22	φ20	-	-	22	6 × 2.8	-	-	-	-	281.9
S2S 25B - 1214	25	φ50	φ54	B1	12	φ14	φ42	10	22	-	-	-	-	-	221.7
S2S 25B - 1414	25	φ50	φ54	B1	14	φ14	φ32	10	24	-	-	-	-	-	250.1
S2S 25B # 1415	25	φ50	φ54	B1	14	φ15	φ32	10	24	5 × 2.3	M4	5	-	-	243.1
S2S 25B # 1416	25	φ50	φ54	B1	14	φ16	φ32	10	24	5 × 2.3	M4	5	-	-	238.6
S2S 25BF - 2008	25	φ50	φ54	B1	20	φ 8(H8)	φ40	20	40	-	-	-	-	-	486.2
S2S 25B - 2008H	25	φ50	φ54	B1	20	φ 8(H※)	φ40	20	40	-	-	-	-	-	486.2
S2S 25B - 2014N	25	φ50	φ54	B1	20	φ14	φ44	10	30	-	-	-	-	-	391.6
S2S 25B - 2214	25	φ50	φ54	B1	22	φ14	φ40	10	32	-	-	-	-	-	399.3
S2S 25B # 2215	25	φ50	φ54	B1	22	φ15	φ40	10	32	5 × 2.3	M4	5	-	-	389.9
S2S 25B # 2220	25	φ50	φ54	B1	22	φ20	φ40	10	32	6 × 2.8	M5	5	-	-	353.9
S2S 26B - 1414	26	φ52	φ56	B1	14	φ14	φ46	10	24	-	-	-	-	-	335.1
S2S 26B - 2214	26	φ52	φ56	B1	22	φ14	φ46	10	32	-	-	-	-	-	458.9

●の商品は新商品です。Products with ● marks are new item.

【=】(イコール)にはキー材が付いております。【=】: Gear with key way / with key

【#】(シャープ)にはキー材とセットスクリューが付いております。【#】: Gear with key way and threaded hole / with key and screw.

カタログ記号の末尾に【H】を付した商品は歯部高周波焼入済です。Gear tooth surface completed with induction hardening, Hardness HRC47 to 53.

※
歯部高周波焼入後の穴修正は行っていません。Bore correcting after induction hardening is not completed.

追加加工の際は、追加加工時の注意をご参照ください。Please refer to Precaution for additional process when additional process.

許容伝達動力表 曲げ強さ (kW)

Allowable transfer capability table (kW) Bending Strength

歯数 z	歯幅 b	焼入 H	回転速度 (min ⁻¹) revolution/min						
			10	100	200	400	800	1,200	1,500
25	12		0.051	0.52	1.03	2.05	3.54	4.73	5.74
25	14		0.060	0.60	1.20	2.39	4.13	5.52	6.70
25	20	-	0.086	0.860	1.720	3.420	5.920	7.910	9.600
25	20	○	0.091	0.913	1.827	3.630	6.359	8.569	10.420
25	22		0.094	0.94	1.89	3.75	6.49	8.67	10.52
26	14		0.063	0.63	1.27	2.51	4.32	5.80	7.03
26	22		0.100	1.00	2.00	3.94	6.78	9.12	11.05

The above references are JGMA standard.

動力の換算式はP26をご参照ください。Please refer to the conversion formulas of power on page P26.

許容伝達動力表 歯面強さ (kW)

Allowable transfer capability table (kW) Surface Durability

回転速度 (min ⁻¹) revolution/min						
10	100	200	400	800	1,200	1,500
-	-	-	-	-	-	-
-	-	-	-	-	-	-
0.004	0.040	0.090	0.180	0.320	0.440	0.550
0.020	0.219	0.451	0.925	1.670	2.291	2.813
-	-	-	-	-	-	-
-	-	-	-	-	-	-
-	-	-	-	-	-	-

JIS B 1702-1 (ISO) 8級
System of accuracy : JIS B 1702-1(ISO) class 8



御注文には必ず“フルネームで商品記号”を明記してください。

Please refer to the catalogue reference while ordering.

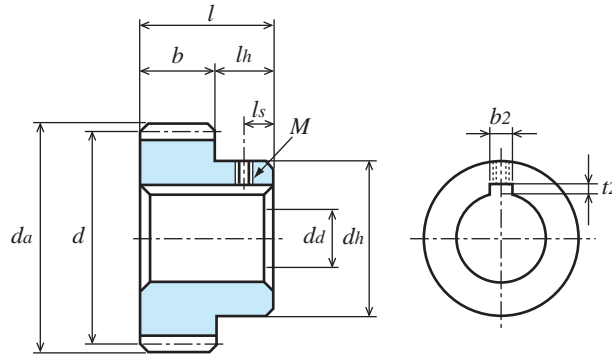

B1形
TYPE B1

S45C 機械構造用炭素鋼 (JIS G 4051)

Material : Carbon Steel (ISO C45)

単位 : mm
Dimensions : mm

商品記号 Catalogue Number	歯数 Number of Teeth z	基準円直径 Reference Diameter d	歯先円直径 Outside Diameter da	形 Type	歯幅 Face Width b	穴径 Bore Diameter da(H7)	ハブ外径 Hub Diameter dh	ハブ長さ Hub Projection lh	全長 Overall Length l	キーみぞ Key Way b2 × t2	ねじ Set Screw		リム内径 Dimension of Rim di	ウエブ厚さ Thickness of Web bw	重量 Weight W(g)
											M	ls			
S2S 28A - 1214F	28	φ56	φ60	A1	12	φ14	-	-	12	-	-	-	-	-	217.5
S2S 28A - 1414F	28	φ56	φ60	A1	14	φ14	-	-	14	-	-	-	-	-	253.8
S2S 28A = 1415	28	φ56	φ60	A1	14	φ15	-	-	14	5 × 2.3	-	-	-	-	250.0
S2S 28A = 1416	28	φ56	φ60	A1	14	φ16	-	-	14	5 × 2.3	-	-	-	-	247.3
S2S 28A = 1420	28	φ56	φ60	A1	14	φ20	-	-	14	6 × 2.8	-	-	-	-	234.3
S2S 28A - 2016F	28	φ56	φ60	A1	20	φ16	-	-	20	-	-	-	-	-	355.1
S2S 28A - 2216F	28	φ56	φ60	A1	22	φ16	-	-	22	-	-	-	-	-	390.6
S2S 28A = 2220	28	φ56	φ60	A1	22	φ20	-	-	22	6 × 2.8	-	-	-	-	368.2
S2S 28A = 2225	28	φ56	φ60	A1	22	φ25	-	-	22	8 × 3.3	-	-	-	-	336.0
S2S 28B - 1214	28	φ56	φ60	B1	12	φ14	φ48	10	22	-	-	-	-	-	304.3
S2S 28B - 1414	28	φ56	φ60	B1	14	φ14	φ40	10	24	-	-	-	-	-	340.6
S2S 28B # 1415	28	φ56	φ60	B1	14	φ15	φ40	10	24	5 × 2.3	M4	5	-	-	333.3
S2S 28B # 1416	28	φ56	φ60	B1	14	φ16	φ40	10	24	5 × 2.3	M4	5	-	-	328.7
S2S 28B # 1420	28	φ56	φ60	B1	14	φ20	φ40	10	24	6 × 2.8	M5	5	-	-	306.3
S2S 28B - 2016N	28	φ56	φ60	B1	20	φ16	φ50	10	30	-	-	-	-	-	493.8
S2S 28B - 2216	28	φ56	φ60	B1	22	φ16	φ50	10	32	-	-	-	-	-	529.3
S2S 28B # 2220	28	φ56	φ60	B1	22	φ20	φ50	10	32	6 × 2.8	M5	5	-	-	495.1
S2S 28B # 2225	28	φ56	φ60	B1	22	φ25	φ50	10	32	8 × 3.3	M6	5	-	-	448.2
S2S 29B - 1414	29	φ58	φ62	B1	14	φ14	φ52	10	24	-	-	-	-	-	428.4
S2S 29B - 2216	29	φ58	φ62	B1	22	φ16	φ52	10	32	-	-	-	-	-	572.9

[=] (イコール) にはキー材が付いております。 [=] : Gear with key way / with key

[#] (シャープ) にはキー材とセットスクリューが付いております。 [#] : Gear with key way and threaded hole / with key and screw.

許容伝達動力表 曲げ強さ (kW)

T (N · m)

Allowable transfer capability table (kW) Bending Strength

歯数 z	歯幅 b	回転速度 (min ⁻¹) revolution/min							回転速度 (min ⁻¹) revolution/min
		10	100	200	400	800	1,200	1,500	
28	12	0.060	0.60	1.21	2.35	4.01	5.46	6.60	100
28	14	0.070	0.70	1.41	2.74	4.68	6.37	7.70	57.29
28	20	0.101	1.01	2.01	3.92	6.69	9.10	11.01	66.84
28	22	0.111	1.11	2.21	4.31	7.36	10.01	12.11	96.45
29	14	0.073	0.74	1.48	2.86	4.86	6.65	8.04	106.00
29	22	0.116	1.16	2.32	4.50	7.64	10.45	12.63	70.66
									110.77

KG 規格は“並幅” (軽荷重用) と“広幅” (重荷重用) があります。ご用途に応じてお選び下さい。

KG STOCK GEARS has Wide-face width for Heavy load, and Standard-face width for Light load.

You are able to multiple choices for your suitable design from our wide range.

The above numerical values are equivalent to JGMA formulas as reference only.

動力の換算式は P26 をご参照ください。 Please refer to the conversion fomulas of power on page P26.

平歯車

SPUR GEARS

モジュール
MODULE

2

圧力角 20° (並歯) 歯数 30

20° PRESSURE ANGLE FULL DEPTH TOOTH Z 30

JIS B 1702-1 (ISO) 8級 (高周波焼入品: 9級)
System of accuracy: JIS B 1702-1(ISO) class 8
(Induction hardened products: class 9)



仕様変更 省スペース・軽量化、締結加工不要。

Specification change Space-saving and weight saving.
Additional machining on tightening is not necessary.

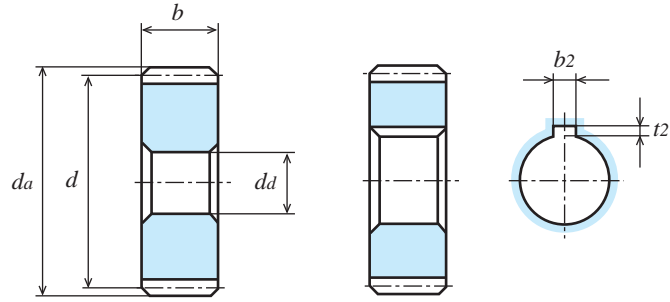

A1形
TYPE A1

A1形
TYPE A1

S45C 機械構造用炭素鋼 (JIS G 4051)

Material: Carbon Steel (ISO C45)

単位: mm
Dimensions: mm

商品記号 Catalogue Number	歯数 Number of Teeth z	基準円直径 Reference Diameter d	歯先円直径 Outside Diameter da	形 Type	歯幅 Face Width b	穴径 Bore Diameter da(H7)	ハブ外径 Hub Diameter dh	ハブ長さ Hub Projection lh	全長 Overall Length l	キミぞ Key Way b2 × t2	ねじ Set Screw		リム内径 Dimension of Rim di	ウェブ厚さ Thickness of Web bw	重量 Weight W(g)
											M	ls			
S2S 30A - 1216F	30	φ60	φ64	A1	12	φ16	-	-	12	-	-	-	-	-	247.4
S2S 30A - 1414F	30	φ60	φ64	A1	14	φ14	-	-	14	-	-	-	-	-	293.8
S2S 30A = 1415	30	φ60	φ64	A1	14	φ15	-	-	14	5 × 2.3	-	-	-	-	290.1
S2S 30A = 1418	30	φ60	φ64	A1	14	φ18	-	-	14	6 × 2.8	-	-	-	-	280.9
S2S 30A = 1420	30	φ60	φ64	A1	14	φ20	-	-	14	6 × 2.8	-	-	-	-	274.4
S2S 30A - 2016F	30	φ60	φ64	A1	20	φ16	-	-	20	-	-	-	-	-	412.3
S2S 30A = 2020	30	φ60	φ64	A1	20	φ20	-	-	20	6 × 2.8	-	-	-	-	391.9
S2S 30A - 2216F	30	φ60	φ64	A1	22	φ16	-	-	22	-	-	-	-	-	453.6
S2S 30A = 2220	30	φ60	φ64	A1	22	φ20	-	-	22	6 × 2.8	-	-	-	-	431.1
S2S 30A = 2225	30	φ60	φ64	A1	22	φ25	-	-	22	8 × 3.3	-	-	-	-	399.0
S2S 30B - 1214	30	φ60	φ64	B1	12	φ14	φ52	10	22	-	-	-	-	-	338.6
S2S 30B - 1414	30	φ60	φ64	B1	14	φ14	φ40	10	24	-	-	-	-	-	380.6
S2S 30B # 1415	30	φ60	φ64	B1	14	φ15	φ40	10	24	5 × 2.3	M4	5	-	-	373.3
S2S 30B # 1416	30	φ60	φ64	B1	14	φ16	φ40	10	24	5 × 2.3	M4	5	-	-	368.8
S2S 30B # 1418	30	φ60	φ64	B1	14	φ18	φ40	10	24	6 × 2.8	M5	5	-	-	357.5
S2S 30B # 1420	30	φ60	φ64	B1	14	φ20	φ40	10	24	6 × 2.8	M5	5	-	-	346.3
S2S 30BF - 2010	30	φ60	φ64	B1	20	φ10(H8)	φ50	20	40	-	-	-	-	-	723.5
S2S 30BF - 2010H	30	φ60	φ64	B1	20	φ10(H※)	φ50	20	40	-	-	-	-	-	723.5
S2S 30B - 2018N	30	φ60	φ64	B1	20	φ18	φ54	10	30	-	-	-	-	-	564.1
S2S 30B - 2216	30	φ60	φ64	B1	22	φ16	φ50	10	32	-	-	-	-	-	592.3
S2S 30B # 2220	30	φ60	φ64	B1	22	φ20	φ50	10	32	6 × 2.8	M5	5	-	-	558.1
S2S 30B # 2225	30	φ60	φ64	B1	22	φ25	φ50	10	32	8 × 3.3	M6	5	-	-	511.1

●の商品は新商品です。Products with ● marks are new item.

【=】(イコール)にはキー材が付いております。【=】: Gear with key way / with key

【#】(シャープ)にはキー材とセットスクリューが付いております。【#】: Gear with key way and threaded hole / with key and screw.

カタログ記号の末尾に【H】を付した商品は歯部高周波焼入済です。Gear tooth surface completed with induction hardening, Hardness HRC47 to 53.

※
歯部高周波焼入後の穴修正は行っていません。Bore correcting after induction hardening is not completed.

追加加工の際は、追加加工時の注意をご参照ください。Please refer to Precaution for additional process when additional process.

許容伝達動力表 曲げ強さ (kW)

Allowable transfer capability table (kW) Bending Strength

歯数 z	歯幅 b	焼入 H	回転速度 (min ⁻¹) revolution/min						
			10	100	200	400	800	1,200	1,500
30	12	-	0.066	0.66	1.32	2.55	4.32	5.94	7.17
30	14	-	0.077	0.77	1.55	2.98	5.04	6.93	8.36
30	20	-	0.110	1.100	2.210	4.260	7.200	9.900	11.960
30	20	○	0.117	1.171	2.342	4.527	7.767	10.748	13.008
30	22	-	0.121	1.21	2.43	4.68	7.92	10.88	13.14

The above references are JGMA standard.

動力の換算式はP26をご参照ください。Please refer to the conversion formulas of power on page P26.

許容伝達動力表 歯面強さ (kW)

Allowable transfer capability table (kW) Surface Durability

回転速度 (min ⁻¹) revolution/min						
10	100	200	400	800	1,200	1,500
-	-	-	-	-	-	-
0.007	0.070	0.130	0.260	0.450	0.640	0.790
0.029	0.321	0.661	1.318	2.331	3.283	4.013
-	-	-	-	-	-	-

平歯車

SPUR GEARS

モジュール
MODULE

2

圧力角 20° (並歯) 歯数 32 ~ 35
20° PRESSURE ANGLE FULL DEPTH TOOTH Z 32 to Z 35

JIS B 1702-1 (ISO) 8級
System of accuracy : JIS B 1702-1(ISO) class 8



御注文には必ず“フルネームで商品記号”を明記してください。

Please refer to the catalogue reference while ordering.

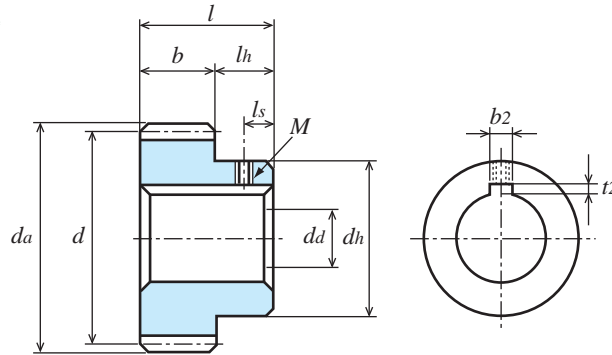

B1形
TYPE B1

S45C 機械構造用炭素鋼 (JIS G 4051) Material : Carbon Steel (ISO C45)

単位 : mm
Dimensions : mm

商品記号 Catalogue Number	歯数 Number of Teeth z	基準円直径 Reference Diameter d	歯先円直径 Outside Diameter da	形 Type	歯幅 Face Width b	穴径 Bore Diameter da(H7)	ハブ外径 Hub Diameter dh	ハブ長さ Hub Projection lh	全長 Overall Length l	キミぞ Key Way b2 × t2	ねじ Set Screw		リム内径 Dimension of Rim di	ウエブ厚さ Thickness of Web bw	重量 Weight W(g)
											M	ls			
S2S 32A - 1214F	32	φ64	φ68	A1	12	φ14	-	-	12	-	-	-	-	288.5	
S2S 32A = 1215	32	φ64	φ68	A1	12	φ15	-	-	12	5 × 2.3	-	-	-	285.3	
S2S 32A = 1218	32	φ64	φ68	A1	12	φ18	-	-	12	6 × 2.8	-	-	-	277.5	
S2S 32A = 1220	32	φ64	φ68	A1	12	φ20	-	-	12	6 × 2.8	-	-	-	271.9	
S2S 32A - 2016F	32	φ64	φ68	A1	20	φ16	-	-	20	-	-	-	-	473.5	
S2S 32A = 2020	32	φ64	φ68	A1	20	φ20	-	-	20	6 × 2.8	-	-	-	453.1	
S2S 32A = 2025	32	φ64	φ68	A1	20	φ25	-	-	20	8 × 3.3	-	-	-	423.9	
S2S 32B - 1214	32	φ64	φ68	B1	12	φ14	φ40	10	22	-	-	-	-	375.3	
S2S 32B # 1215	32	φ64	φ68	B1	12	φ15	φ40	10	22	5 × 2.3	M4	5	-	368.6	
S2S 32B # 1220	32	φ64	φ68	B1	12	φ20	φ40	10	22	6 × 2.8	M5	5	-	343.8	
S2S 32B - 2016	32	φ64	φ68	B1	20	φ16	φ50	10	30	-	-	-	-	621.2	
S2S 32B # 2020	32	φ64	φ68	B1	20	φ20	φ50	10	30	6 × 2.8	M5	5	-	580.1	
S2S 32B # 2025	32	φ64	φ68	B1	20	φ25	φ50	10	30	8 × 3.3	M6	5	-	536.0	
S2S 34B - 1214	34	φ68	φ72	B1	12	φ14	φ60	10	22	-	-	-	-	537.8	
S2S 34B - 2016	34	φ68	φ72	B1	20	φ16	φ60	10	30	-	-	-	-	745.3	
S2S 35A - 1216F	35	φ70	φ74	A1	12	φ16	-	-	12	-	-	-	-	343.6	
S2S 35A - 2020F	35	φ70	φ74	A1	20	φ20	-	-	20	-	-	-	-	554.9	
S2S 35B - 1214	35	φ70	φ74	B1	12	φ14	φ60	10	22	-	-	-	-	558.3	
S2S 35B - 2016	35	φ70	φ74	B1	20	φ16	φ60	10	30	-	-	-	-	779.3	

【=】(イコール)にはキー材が付いております。【=】: Gear with key way / with key

【#】(シャープ)にはキー材とセットスクリューが付いております。【#】: Gear with key way and threaded hole / with key and screw.

許容伝達動力表 曲げ強さ (kW)

T (N · m)

Allowable transfer capability table (kW) Bending Strength

歯数 z	歯幅 b	回転速度 (min ⁻¹) revolution/min								回転速度 (min ⁻¹) revolution/min
		10	100	200	400	800	1,200	1,500	100	
32	12	0.072	0.72	1.44	2.75	4.61	6.41	7.73	68.75	
32	20	0.120	1.20	2.41	4.58	7.69	10.69	12.89	114.59	
34	12	0.078	0.78	1.57	2.94	4.90	6.89	8.32	74.48	
34	20	0.130	1.30	2.61	4.90	8.17	11.48	13.86	124.14	
35	12	0.081	0.81	1.63	3.04	5.04	7.12	8.61	77.35	
35	20	0.135	1.35	2.71	5.07	8.40	11.87	14.35	128.92	

KG規格は“並幅”(軽荷重用)と“広幅”(重荷重用)があります。ご用途に応じてお選び下さい。

KG STOCK GEARS has Wide-face width for Heavy load, and Standard-face width for Light load.

You are able to multiple choices for your suitable design from our wide range.

The above numerical values are equivalent to JGMA formulas as reference only.

動力の換算式はP26をご参照ください。Please refer to the conversion fomulas of power on page P26.

目次
CONTENTS

インフォメーション
INFORMATION

ギヤボックス
GEAR BOXES

ノーバッキングギヤ
ANTI BACKLASH SPUR GEARS

歯研研歯車
GROUND SPUR GEARS

歯研研歯車
SPUR GEAR

内歯車
INTERNAL GEARS

歯研研歯車
GROUND RACKS

ラック
RACKS

ハニカム
HEXAGONAL GEAR AND SCREW GEARS

ワーム
WORMS AND WORM WHEELS

かさ歯車
BEVEL GEARS

スプロケット
SPROCKETS

技術仕様書
REFERENCE DATA

平歯車 SPUR GEARS

モジュール
MODULE

2

圧力角 20° (並歯) 歯数 36 38

20° PRESSURE ANGLE FULL DEPTH TOOTH Z36 to Z38

JIS B 1702-1 (ISO) 8級
System of accuracy : JIS B 1702-1(ISO) class 8



仕様変更 省スペース・軽量化、締結加工不要。

Specification change Space-saving and weight saving.
Additional machining on tightening is not necessary.

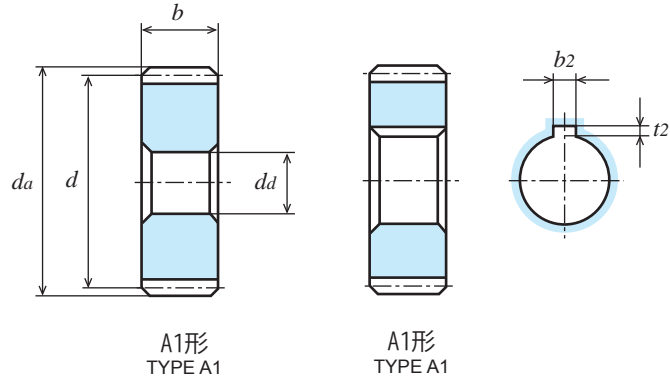

S45C 機械構造用炭素鋼 (JIS G 4051)

Material : Carbon Steel (ISO C45)

単位 : mm
Dimensions : mm

商品記号 Catalogue Number	歯数 Number of Teeth <i>z</i>	基準円直径 Reference Diameter <i>d</i>	歯先円直径 Outside Diameter <i>da</i>	形 Type	歯幅 Face Width <i>b</i>	穴径 Bore Diameter <i>da</i> (H7)	ハブ外径 Hub Diameter <i>dh</i>	ハブ長さ Hub Projection <i>lh</i>	全長 Overall Length <i>l</i>	キミぞ Key Way <i>b2 × t2</i>	ねじ Set Screw		リム内径 Dimension of Rim <i>di</i>	ウェブ厚さ Thickness of Web <i>bw</i>	重量 Weight <i>W</i> (kg)
											<i>M</i>	<i>ls</i>			
S2S 36A - 1216F	36	φ72	φ76	A1	12	φ16	-	-	12	-	-	-	-	-	0.36
S2S 36A = 1220	36	φ72	φ76	A1	12	φ20	-	-	12	6 × 2.8	-	-	-	-	0.35
S2S 36A - 2016F	36	φ72	φ76	A1	20	φ16	-	-	20	-	-	-	-	-	0.61
S2S 36A = 2020	36	φ72	φ76	A1	20	φ20	-	-	20	6 × 2.8	-	-	-	-	0.59
S2S 36A = 2025	36	φ72	φ76	A1	20	φ25	-	-	20	8 × 3.3	-	-	-	-	0.56
S2S 36B - 1214	36	φ72	φ76	B1	12	φ14	φ40	10	22	-	-	-	-	-	0.46
S2S 36B # 1215	36	φ72	φ76	B1	12	φ15	φ40	10	22	5 × 2.3	M4	5	-	-	0.45
S2S 36B # 1216	36	φ72	φ76	B1	12	φ16	φ40	10	22	5 × 2.3	M4	5	-	-	0.44
S2S 36B # 1218	36	φ72	φ76	B1	12	φ18	φ40	10	22	6 × 2.8	M5	5	-	-	0.43
S2S 36B # 1220	36	φ72	φ76	B1	12	φ20	φ40	10	22	6 × 2.8	M5	5	-	-	0.42
S2S 36B - 2016	36	φ72	φ76	B1	20	φ16	φ50	10	30	-	-	-	-	-	0.75
S2S 36B # 2020	36	φ72	φ76	B1	20	φ20	φ50	10	30	6 × 2.8	M5	5	-	-	0.71
S2S 36B # 2025	36	φ72	φ76	B1	20	φ25	φ50	10	30	8 × 3.3	M6	5	-	-	0.67
S2S 38B - 1214	38	φ76	φ80	B1	12	φ14	φ60	10	22	-	-	-	-	-	0.62
S2S 38B - 2016	38	φ76	φ80	B1	20	φ16	φ60	10	30	-	-	-	-	-	0.89

【=】(イコール)にはキマ材が付いております。【=】: Gear with key way / with key

【#】(シャープ)にはキマ材とセットスクリューが付いております。【#】: Gear with key way and threaded hole / with key and screw.

許容伝達動力表 曲げ強さ (kW)

T (N · m)

Allowable transfer capability table (kW) Bending Strength

歯数 <i>z</i>	歯幅 <i>b</i>	回転速度 (min ⁻¹) revolution/min							回転速度 (min ⁻¹) revolution/min
		10	100	200	400	800	1,200	1,500	
36	12	0.084	0.84	1.69	3.13	5.19	7.35	8.90	100
36	20	0.141	1.41	2.81	5.22	8.64	12.26	14.83	80.21
38	12	0.090	0.90	1.81	3.32	5.53	7.82	9.47	134.65
38	20	0.151	1.51	3.02	5.54	9.21	13.03	15.79	85.94
									144.20

The above numerical values are equivalent to JGMA formulas as reference only.

動力の換算式は P26 をご参照ください。Please refer to the conversion formulas of power on page P26.

平歯車

SPUR GEARS

モジュール
MODULE

2

圧力角 20° (並歯) 歯数 40

20° PRESSURE ANGLE FULL DEPTH TOOTH Z 40

JIS B 1702-1 (ISO) 8級 (高周波焼入品: 9級)
System of accuracy: JIS B 1702-1(ISO) class 8
(Induction hardened products: class 9)



御注文には必ず“フルネームで商品記号”を明記してください。

Please refer to the catalogue reference while ordering.

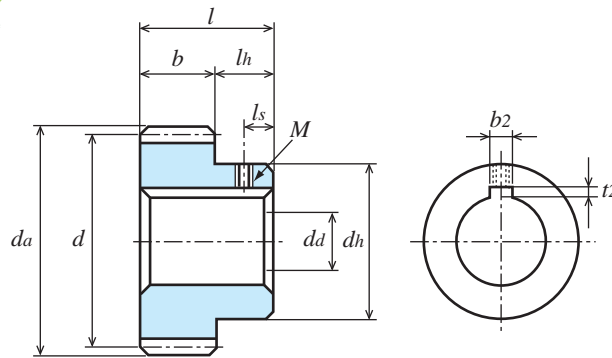

B1形
TYPE B1

S45C 機械構造用炭素鋼 (JIS G 4051)

Material: Carbon Steel (ISO C45)

単位: mm
Dimensions: mm

商品記号 Catalogue Number	歯数 Number of Teeth z	基準円直径 Reference Diameter d	歯先円直径 Outside Diameter da	形 Type	歯幅 Face Width b	穴径 Bore Diameter da(H7)	ハブ外径 Hub Diameter dh	ハブ長さ Hub Projection lh	全長 Overall Length l	キミぞ Key Way b2 × t2	ねじ Set Screw		リム内径 Dimension of Rim di	ウェブ厚さ Thickness of Web bw	重量 Weight W(kg)
											M	ls			
S2S 40A - 1216F	40	φ80	φ84	A1	12	φ16	-	-	12	-	-	-	-	0.45	
S2S 40A = 1220	40	φ80	φ84	A1	12	φ20	-	-	12	6 × 2.8	-	-	-	0.44	
S2S 40A - 2016F	40	φ80	φ84	A1	20	φ16	-	-	20	-	-	-	-	0.76	
S2S 40A = 2020	40	φ80	φ84	A1	20	φ20	-	-	20	6 × 2.8	-	-	-	0.74	
S2S 40A = 2025	40	φ80	φ84	A1	20	φ25	-	-	20	8 × 3.3	-	-	-	0.71	
S2S 40B - 1214	40	φ80	φ84	B1	12	φ14	φ40	10	22	-	-	-	-	0.55	
S2S 40B # 1215	40	φ80	φ84	B1	12	φ15	φ40	10	22	5 × 2.3	M4	5	-	0.54	
S2S 40B # 1216	40	φ80	φ84	B1	12	φ16	φ40	10	22	5 × 2.3	M4	5	-	0.53	
S2S 40B # 1218	40	φ80	φ84	B1	12	φ18	φ40	10	22	6 × 2.8	M5	5	-	0.52	
S2S 40B # 1220	40	φ80	φ84	B1	12	φ20	φ40	10	22	6 × 2.8	M5	5	-	0.51	
● S2S 40BF - 2010	40	φ80	φ84	B1	20	φ10(H8)	φ60	20	40	-	-	-	-	1.2	
● S2S 40B - 2010H	40	φ80	φ84	B1	20	φ10(H※)	φ60	20	40	-	-	-	-	1.2	
S2S 40B - 2016	40	φ80	φ84	B1	20	φ16	φ50	10	30	-	-	-	-	0.90	
S2S 40B # 2020	40	φ80	φ84	B1	20	φ20	φ50	10	30	6 × 2.8	M5	5	-	0.86	
S2S 40B # 2025	40	φ80	φ84	B1	20	φ25	φ50	10	30	8 × 3.3	M6	5	-	0.82	

●の商品は新商品です。Products with ● marks are new item.

【=】(イコール)にはキー材が付いております。【=】: Gear with key way / with key

【#】(シャープ)にはキー材とセットスクリューが付いております。【#】: Gear with key way and threaded hole / with key and screw.

カタログ記号の末尾に【H】を付した商品は歯部高周波焼入済です。Gear tooth surface completed with induction hardening, Hardness HRC47 to 53.

※ 歯部高周波焼入後の穴修正は行っていません。Bore correcting after induction hardening is not completed.

追加加工の際は、追加加工時の注意をご参照ください。Please refer to Precaution for additional process when additional process.

許容伝達動力表 曲げ強さ (kW)

Allowable transfer capability table (kW) Bending Strength

歯数 z	歯幅 b	焼入 H	回転速度 (min ⁻¹) revolution/min						
			10	100	200	400	800	1,200	1,500
40	12	-	0.10	0.97	1.93	3.51	5.87	8.28	10.05
40	20	-	0.160	1.610	3.210	5.840	9.760	13.760	16.700
40	20	○	0.170	1.703	3.407	6.239	10.575	14.990	18.738

The above references are JGMA standard.

動力の換算式はP26をご参照ください。Please refer to the conversion formulas of power on page P26.

許容伝達動力表 歯面強さ (kW)

Allowable transfer capability table (kW) Surface Durability

回転速度 (min ⁻¹) revolution/min						
10	100	200	400	800	1,200	1,500
-	-	-	-	-	-	-
0.012	0.120	0.240	0.450	0.790	1.160	1.450
0.053	0.586	1.209	2.282	3.986	5.752	7.261

目次
CONTENTS

インフォメーション
INFORMATION

ギヤボックス
GEAR BOXES

ノーバッキングギヤ
ANTI BACKLASH SPUR GEARS

歯研削歯車
GROUND SPUR GEARS

歯研削歯車
SPUR GEARS

内歯車
INTERNAL GEARS

歯研削ラック
GROUND RACKS

ラック
RACKS

ハニカムギヤ
HELIICAL GEARS AND SCREW GEARS

ウォーム
WORMS AND WORM WHEELS

かさ歯車
BEVEL GEARS

スプロケット
SPROCKETS

技術資料
REFERENCE DATA

平歯車 SPUR GEARS

モジュール
MODULE

2

圧力角 20° (並歯) 歯数 42 ~ 48

20° PRESSURE ANGLE FULL DEPTH TOOTH Z 42 to Z 48

JIS B 1702-1 (ISO) 8級
System of accuracy : JIS B 1702-1(ISO) class 8



仕様変更 省スペース・軽量化、締結加工不要。

Specification change Space-saving and weight saving.
Additional machining on tightening is not necessary.

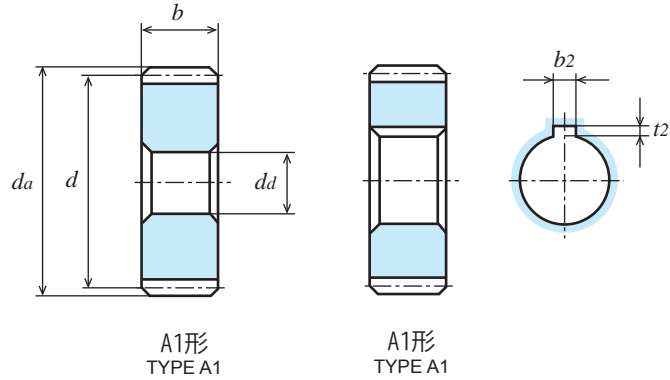

S45C 機械構造用炭素鋼 (JIS G 4051) Material : Carbon Steel (ISO C45)

単位 : mm
Dimensions : mm

商品記号 Catalogue Number	歯数 Number of Teeth z	基準円直径 Reference Diameter d	歯先円直径 Outside Diameter da	形 Type	歯幅 Face Width b	穴径 Bore Diameter da(H7)	ハブ外径 Hub Diameter dh	ハブ長さ Hub Projection lh	全長 Overall Length l	キミぞ Key Way b2 × t2	ねじ Set Screw		リム内径 Dimension of Rim di	ウエブ厚さ Thickness of Web bw	重量 Weight W(kg)
											M	ls			
S2S 42B - 1214	42	φ84	φ 88	B1	12	φ14	φ60	10	22	-	-	-	-	0.72	
S2S 42B - 2016	42	φ84	φ 88	B1	20	φ16	φ60	10	30	-	-	-	-	1.05	
S2S 44B - 1214	44	φ88	φ 92	B1	12	φ14	φ60	10	22	-	-	-	-	0.77	
S2S 44B - 2016	44	φ88	φ 92	B1	20	φ16	φ60	10	30	-	-	-	-	1.13	
S2S 45A - 1218F	45	φ90	φ 94	A1	12	φ18	-	-	12	-	-	-	-	0.58	
S2S 45A - 2020F	45	φ90	φ 94	A1	20	φ20	-	-	20	-	-	-	-	0.95	
S2S 45B - 1214	45	φ90	φ 94	B1	12	φ14	φ60	10	22	-	-	-	-	0.80	
S2S 45B - 2016	45	φ90	φ 94	B1	20	φ16	φ60	10	30	-	-	-	-	1.17	
S2S 46B - 1214	46	φ92	φ 96	B1	12	φ14	φ60	10	22	-	-	-	-	0.82	
S2S 46B - 2016	46	φ92	φ 96	B1	20	φ16	φ60	10	30	-	-	-	-	1.22	
S2S 48A - 1218F	48	φ96	φ100	A1	12	φ18	-	-	12	-	-	-	-	0.66	
S2S 48A = 1220	48	φ96	φ100	A1	12	φ20	-	-	12	6 × 2.8	-	-	-	0.65	
S2S 48A - 2018F	48	φ96	φ100	A1	20	φ18	-	-	20	-	-	-	-	1.10	
S2S 48A = 2020	48	φ96	φ100	A1	20	φ20	-	-	20	6 × 2.8	-	-	-	1.08	
S2S 48A = 2025	48	φ96	φ100	A1	20	φ25	-	-	20	8 × 3.3	-	-	-	1.06	
S2S 48B - 1216	48	φ96	φ100	B1	12	φ16	φ40	10	22	-	-	-	-	0.75	
S2S 48B # 1220	48	φ96	φ100	B1	12	φ20	φ40	10	22	6 × 2.8	M5	5	-	0.72	
S2S 48B - 2018	48	φ96	φ100	B1	20	φ18	φ50	10	30	-	-	-	-	1.23	
S2S 48B # 2020	48	φ96	φ100	B1	20	φ20	φ50	10	30	6 × 2.8	M5	5	-	1.21	
S2S 48B # 2025	48	φ96	φ100	B1	20	φ25	φ50	10	30	8 × 3.3	M6	5	-	1.17	

【=】(イコール)にはキー材が付いております。【=】: Gear with key way / with key

【#】(シャープ)にはキー材とセットスクリューが付いております。【#】: Gear with key way and threaded hole / with key and screw.

許容伝達動力表 曲げ強さ (kW)

T (N · m)

Allowable transfer capability table (kW) Bending Strength

歯数 z	歯幅 b	回転速度 (min ⁻¹) revolution/min							回転速度 (min ⁻¹) revolution/min
		10	100	200	400	800	1,200	1,500	
42	12	0.10	1.03	2.06	3.69	6.20	8.75	10.61	100
42	20	0.17	1.71	3.43	6.15	10.34	14.59	17.69	100
44	12	0.11	1.09	2.18	3.87	6.53	9.22	11.17	100
44	20	0.18	1.82	3.63	6.45	10.89	15.37	18.61	100
45	12	0.11	1.12	2.24	3.96	6.70	9.46	11.44	100
45	20	0.19	1.87	3.74	6.60	11.16	15.76	19.07	100
46	12	0.12	1.15	2.30	4.05	6.86	9.69	11.72	100
46	20	0.19	1.92	3.84	6.74	11.44	16.15	19.53	100
48	12	0.12	1.21	2.43	4.22	7.19	10.16	12.27	100
48	20	0.20	2.02	4.04	7.03	11.98	16.93	20.45	100

The above numerical values are equivalent to JGMA formulas as reference only.

動力の換算式は P26 をご参照ください。Please refer to the conversion fomulas of power on page P26.

平歯車

SPUR GEARS

モジュール
MODULE

2

圧力角 20° (並歯) 歯数 50 52

20° PRESSURE ANGLE FULL DEPTH TOOTH Z 50 to Z 52

JIS B 1702-1 (ISO) 8級 (高周波焼入品: 9級)
System of accuracy: JIS B 1702-1(ISO) class 8
(Induction hardened products: class 9)



御注文には必ず“フルネームで商品記号”を明記してください。
Please refer to the catalogue reference while ordering.

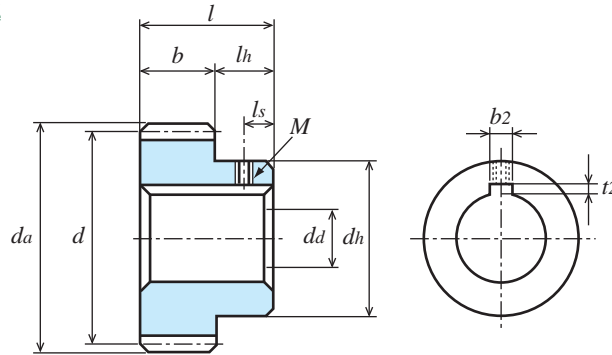

B1形
TYPE B1

S45C 機械構造用炭素鋼 (JIS G 4051)

Material: Carbon Steel (ISO C45)

単位: mm
Dimensions: mm

商品記号 Catalogue Number	歯数 Number of Teeth z	基準円直径 Reference Diameter d	歯先円直径 Outside Diameter da	形 Type	歯幅 Face Width b	穴径 Bore Diameter da(H7)	ハブ外径 Hub Diameter dh	ハブ長さ Hub Projection lh	全長 Overall Length l	キミぞ Key Way b2 × t2	ねじ Set Screw		リム内径 Dimension of Rim di	ウエブ厚さ Thickness of Web bw	重量 Weight W(kg)
											M	ls			
S2S 50A - 1218F	50	φ100	φ104	A1	12	φ18	-	-	12	-	-	-	-	0.72	
S2S 50A = 1220	50	φ100	φ104	A1	12	φ20	-	-	12	6 × 2.8	-	-	-	0.71	
S2S 50A = 1225	50	φ100	φ104	A1	12	φ25	-	-	12	8 × 3.3	-	-	-	0.69	
S2S 50A - 2018F	50	φ100	φ104	A1	20	φ18	-	-	20	-	-	-	-	1.19	
S2S 50A = 2020	50	φ100	φ104	A1	20	φ20	-	-	20	6 × 2.8	-	-	-	1.18	
S2S 50A = 2025	50	φ100	φ104	A1	20	φ25	-	-	20	8 × 3.3	-	-	-	1.15	
S2S 50A = 2030	50	φ100	φ104	A1	20	φ30	-	-	20	8 × 3.3	-	-	-	1.12	
S2S 50B - 1216	50	φ100	φ104	B1	12	φ16	φ50	10	22	-	-	-	-	0.86	
S2S 50B # 1220	50	φ100	φ104	B1	12	φ20	φ50	10	22	6 × 2.8	M5	5	-	0.84	
S2S 50B # 1225	50	φ100	φ104	B1	12	φ25	φ50	10	22	8 × 3.3	M6	5	-	0.80	
● S2S 50BF - 2012	50	φ100	φ104	B1	20	φ12(H8)	φ70	20	40	-	-	-	-	1.8	
● S2S 50B - 2012H	50	φ100	φ104	B1	20	φ12(H※)	φ70	20	40	-	-	-	-	1.8	
S2S 50B - 2018	50	φ100	φ104	B1	20	φ18	φ60	10	30	-	-	-	-	1.40	
S2S 50B # 2020	50	φ100	φ104	B1	20	φ20	φ60	10	30	6 × 2.8	M5	5	-	1.38	
S2S 50B # 2025	50	φ100	φ104	B1	20	φ25	φ60	10	30	8 × 3.3	M6	5	-	1.33	
S2S 50B # 2030	50	φ100	φ104	B1	20	φ30	φ60	10	30	8 × 3.3	M6	5	-	1.28	
S2S 52B - 1216	52	φ104	φ108	B1	12	φ16	φ60	10	22	-	-	-	-	0.99	
S2S 52B - 2018	52	φ104	φ108	B1	20	φ18	φ60	10	30	-	-	-	-	1.50	

●の商品は新商品です。Products with ● marks are new item.

【=】(イコール)にはキー材が付いております。 [=]: Gear with key way / with key

【#】(シャープ)にはキー材とセットスクリューが付いております。[#]: Gear with key way and threaded hole / with key and screw.

カタログ記号の末尾に【H】を付した商品は歯部高周波焼入済です。Gear tooth surface completed with induction hardening, Hardness HRC47 to 53.

※ 歯部高周波焼入後の穴修正は行っていません。Bore correcting after induction hardening is not completed.

追加加工の際は、追加加工時の注意をご参照ください。Please refer to Precaution for additional process when additional process.

許容伝達動力表 曲げ強さ (kW)

Allowable transfer capability table (kW) Bending Strength

歯数 z	歯幅 b	焼入 H	回転速度 (min ⁻¹) revolution/min						
			10	100	200	400	800	1,200	1,500
50	12	-	0.13	1.28	2.54	4.39	7.52	10.62	12.81
50	20	-	0.210	2.120	4.210	7.280	12.470	17.630	21.270
50	20	○	0.225	2.247	4.466	7.822	13.550	19.776	24.720
52	12	-	0.13	1.34	2.64	4.56	7.84	11.08	13.40
52	20	-	0.22	2.23	4.41	7.59	13.06	18.47	22.34

The above references are JGMA standard.

動力の換算式はP26をご参照ください。Please refer to the conversion formulas of power on page P26.

許容伝達動力表 歯面強さ (kW)

Allowable transfer capability table (kW) Surface Durability

回転速度 (min ⁻¹) revolution/min						
10	100	200	400	800	1,200	1,500
-	-	-	-	-	-	-
0.019	0.190	0.390	0.690	1.240	1.860	2.320
0.085	0.936	1.917	3.460	6.180	9.181	11.589
-	-	-	-	-	-	-
-	-	-	-	-	-	-

目次
CONTENTS

インフォメーション
INFORMATION

ギヤボックス
GEAR BOXES

ノーバッキングギヤ
ANTI BACKLASH SPUR GEARS

歯研削歯車
GROUND SPUR GEARS

歯車
SPUR GEARS

内歯車
INTERNAL GEARS

歯ラック
GROUND RACKS

ラック
RACKS

ヘリカルギヤとスクリューギヤ
HELICAL GEARS AND SCREW GEARS

ウォームとウォームギヤ
WORMS AND WORM GEARS

かさ歯車
BEVEL GEARS

スプロケット
SPROCKETS

技術データ
REFERENCE DATA

平歯車 SPUR GEARS

モジュール
MODULE

2

圧力角 20° (並歯) 歯数 55 ~ 56

20° PRESSURE ANGLE FULL DEPTH TOOTH Z 55 to Z 56

JIS B 1702-1 (ISO) 8 級
System of accuracy : JIS B 1702-1(ISO) class 8



仕様変更 省スペース・軽量化、締結加工不要。

Specification change Space-saving and weight saving.
Additional machining on tightening is not necessary.

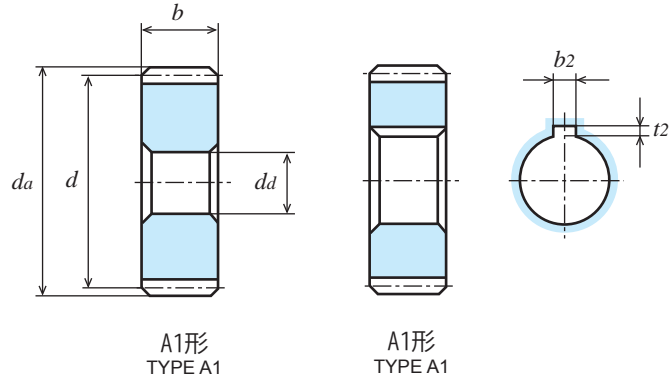

S45C 機械構造用炭素鋼 (JIS G 4051) Material : Carbon Steel (ISO C45)

単位 : mm
Dimensions : mm

商品記号 Catalogue Number	歯数 Number of Teeth <i>z</i>	基準円直径 Reference Diameter <i>d</i>	歯先円直径 Outside Diameter <i>da</i>	形 Type	歯幅 Face Width <i>b</i>	穴径 Bore Diameter <i>da(H7)</i>	ハブ外径 Hub Diameter <i>dh</i>	ハブ長さ Hub Projection <i>lh</i>	全長 Overall Length <i>l</i>	キミぞ Key Way <i>b2 × t2</i>	ねじ Set Screw		リム内径 Dimension of Rim <i>di</i>	ウェブ厚さ Thickness of Web <i>bw</i>	重量 Weight <i>W(kg)</i>
											<i>M</i>	<i>ls</i>			
S2S 55A - 1218F	55	φ110	φ114	A1	12	φ18	-	-	12	-	-	-	-	-	0.87
S2S 55A - 2020F	55	φ110	φ114	A1	20	φ20	-	-	20	-	-	-	-	-	1.44
S2S 55B - 1216	55	φ110	φ114	B1	12	φ16	φ60	10	22	-	-	-	-	-	1.08
S2S 55B - 2018	55	φ110	φ114	B1	20	φ18	φ60	10	30	-	-	-	-	-	1.66
S2S 56A - 1218F	56	φ112	φ116	A1	12	φ18	-	-	12	-	-	-	-	-	0.90
S2S 56A = 1220	56	φ112	φ116	A1	12	φ20	-	-	12	6 × 2.8	-	-	-	-	0.90
S2S 56A - 2020F	56	φ112	φ116	A1	20	φ20	-	-	20	-	-	-	-	-	1.50
S2S 56A = 2025	56	φ112	φ116	A1	20	φ25	-	-	20	8 × 3.3	-	-	-	-	1.47
S2S 56B - 1216	56	φ112	φ116	B1	12	φ16	φ50	10	22	-	-	-	-	-	1.05
S2S 56B # 1220	56	φ112	φ116	B1	12	φ20	φ50	10	22	6 × 2.8	M5	5	-	-	1.02
S2S 56B - 2018	56	φ112	φ116	B1	20	φ18	φ60	10	30	-	-	-	-	-	1.71
S2S 56B # 2020	56	φ112	φ116	B1	20	φ20	φ60	10	30	6 × 2.8	M5	5	-	-	1.69
S2S 56B # 2025	56	φ112	φ116	B1	20	φ25	φ60	10	30	8 × 3.3	M6	5	-	-	1.65

【=】 (イコール) にはキー材が付いております。【=】: Gear with key way / with key

【#】 (シャープ) にはキー材とセットスクリューが付いております。【#】: Gear with key way and threaded hole / with key and screw.

許容伝達動力表 曲げ強さ (kW)

T (N · m)

Allowable transfer capability table (kW) Bending Strength

歯数 <i>z</i>	歯幅 <i>b</i>	回転速度 (min ⁻¹) revolution/min								回転速度 (min ⁻¹) revolution/min
		10	100	200	400	800	1,200	1,500		
55	12	0.14	1.43	2.81	4.80	8.32	11.76	14.35	100	136.56
55	20	0.24	2.39	4.68	8.00	13.86	19.61	23.91	100	228.23
56	12	0.15	1.47	2.86	4.88	8.47	11.99	14.67	100	140.38
56	20	0.24	2.44	4.76	8.13	14.12	19.98	24.44	100	233.01

The above numerical values are equivalent to JGMA formulas as reference only.

動力の換算式は P26 をご参照ください。Please refer to the conversion formulas of power on page P26.

平歯車

SPUR GEARS

モジュール
MODULE

2

圧力角 20° (並歯) 歯数 60

20° PRESSURE ANGLE FULL DEPTH TOOTH Z 60

JIS B 1702-1 (ISO) 8級 (高周波焼入品: 9級)
System of accuracy: JIS B 1702-1(ISO) class 8
(Induction hardened products: class 9)



御注文には必ず“フルネームで商品記号”を明記してください。

Please refer to the catalogue reference while ordering.

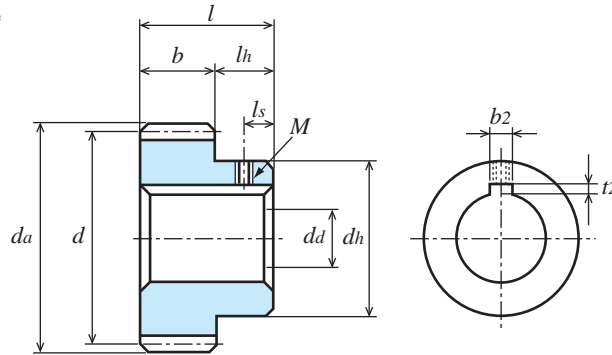

B1形
TYPE B1

S45C 機械構造用炭素鋼 (JIS G 4051)

Material: Carbon Steel (ISO C45)

単位: mm
Dimensions: mm

商品記号 Catalogue Number	歯数 Number of Teeth z	基準円直径 Reference Diameter d	歯先円直径 Outside Diameter da	形 Type	歯幅 Face Width b	穴径 Bore Diameter da(H7)	ハブ外径 Hub Diameter dh	ハブ長さ Hub Projection lh	全長 Overall Length l	キミぞ Key Way b2 × t2	ねじ Set Screw		リム内径 Dimension of Rim di	ウエブ厚さ Thickness of Web bw	重量 Weight W(kg)
											M	ls			
S2S 60A - 1220F	60	φ120	φ124	A1	12	φ20	-	-	12	-	-	-	-	1.04	
S2S 60A = 1225	60	φ120	φ124	A2	12	φ25	φ50	-	12	8 × 3.3	-	-	φ102	6	0.74
S2S 60A - 2018F	60	φ120	φ124	A1	20	φ18	-	-	20	-	-	-	-	1.74	
S2S 60A = 2020	60	φ120	φ124	A2	20	φ20	φ40	-	20	6 × 2.8	-	-	φ102	10	1.22
S2S 60A = 2025	60	φ120	φ124	A2	20	φ25	φ50	-	20	8 × 3.3	-	-	φ102	10	1.24
S2S 60A = 2030	60	φ120	φ124	A2	20	φ30	φ60	-	20	8 × 3.3	-	-	φ102	10	1.28
S2S 60B - 1216	60	φ120	φ124	B1	12	φ16	φ50	10	22	-	-	-	-	1.19	
S2S 60B # 1220	60	φ120	φ124	B3	12	φ20	φ50	10	22	6 × 2.8	M5	5	φ102	6	1.16
S2S 60B # 1225	60	φ120	φ124	B3	12	φ25	φ50	10	22	8 × 3.3	M6	5	φ102	6	1.13
● S2S 60BF - 2012	60	φ120	φ124	B1	20	φ12(H8)	φ85	20	40	-	-	-	-	2.62	
● S2S 60B - 2012H	60	φ120	φ124	B1	20	φ12(H※)	φ85	20	40	-	-	-	-	2.62	
S2S 60B - 2018	60	φ120	φ124	B1	20	φ18	φ60	10	30	-	-	-	-	1.94	
S2S 60B # 2020	60	φ120	φ124	B3	20	φ20	φ60	10	30	6 × 2.8	M5	5	φ102	10	1.92
S2S 60B # 2025	60	φ120	φ124	B3	20	φ25	φ60	10	30	8 × 3.3	M6	5	φ102	10	1.87
S2S 60B # 2030	60	φ120	φ124	B3	20	φ30	φ60	10	30	8 × 3.3	M6	5	φ102	10	1.82

●の商品は新商品です。Products with ● marks are new item.

【=】(イコール)にはキー材が付いております。【=】: Gear with key way / with key

【#】(シャープ)にはキー材とセットスクリューが付いております。【#】: Gear with key way and threaded hole / with key and screw.

カタログ記号の末尾に【H】を付した商品は歯部高周波焼入済です。Gear tooth surface completed with induction hardening, Hardness HRC47 to 53.

※ 歯部高周波焼入後の穴修正は行っていません。Bore correcting after induction hardening is not completed.

追加加工の際は、追加加工時の注意をご参照ください。Please refer to Precaution for additional process when additional process.

許容伝達動力表 曲げ強さ (kW)

Allowable transfer capability table (kW) Bending Strength

歯数 z	歯幅 b	焼入 H	回転速度 (min ⁻¹) revolution/min						
			10	100	200	400	800	1,200	1,500
60	12	-	0.16	1.59	3.07	5.19	9.10	12.88	15.94
60	20	-	0.260	2.640	5.090	8.610	15.080	21.350	26.410
60	20	○	0.280	2.800	5.411	9.285	16.428	24.642	30.802

The above references are JGMA standard.

動力の換算式はP26をご参照ください。Please refer to the conversion formulas of power on page P26.

許容伝達動力表 歯面強さ (kW)

Allowable transfer capability table (kW) Surface Durability

回転速度 (min ⁻¹) revolution/min						
10	100	200	400	800	1,200	1,500
-	-	-	-	-	-	-
0.028	0.280	0.550	0.970	1.810	2.720	3.480
0.124	1.371	2.731	4.830	8.810	13.451	16.980

目次
CONTENTS

インフォメーション
INFORMATION

ギヤボックス
GEAR BOXES

ノーバッキングギヤ
ANTI BACKLASH SPUR GEARS

歯研削歯車
GROUND SPUR GEARS

歯研削歯車
SPUR GEARS

内歯車
INTERNAL GEARS

歯研削歯車
GROUND RACKS

ラック
RACKS

ハニカムギヤ
HELICAL GEARS AND SCREW GEARS

ワーム
WORMS AND WORM WHEELS

かさ歯車
BEVEL GEARS

スプロケット
SPROCKETS

技術データ
REFERENCE DATA

平歯車 SPUR GEARS

モジュール
MODULE

2

圧力角 20° (並歯) 歯数 64 ~ 65

20° PRESSURE ANGLE FULL DEPTH TOOTH Z 64 to Z 65

JIS B 1702-1 (ISO) 8級
System of accuracy : JIS B 1702-1(ISO) class 8



New 仕様変更 省スペース・軽量化、締結加工不要。

Specification change Space-saving and weight saving.
Additional machining on tightening is not necessary.

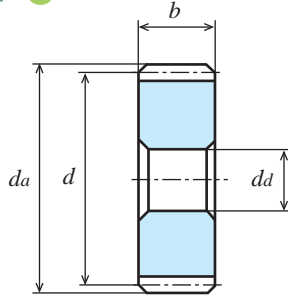

A1形
TYPE A1

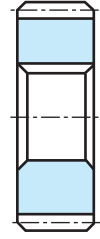

A1形
TYPE A1

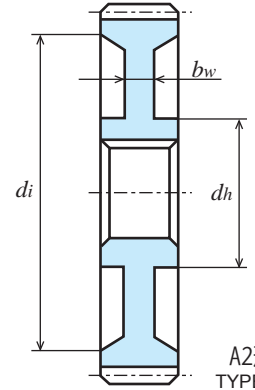
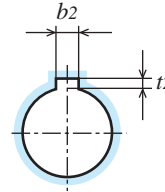

A2形
TYPE A2

S45C 機械構造用炭素鋼 (JIS G 4051) Material : Carbon Steel (ISO C45)

単位 : mm
Dimensions : mm

商品記号 Catalogue Number	歯数 Number of Teeth <i>z</i>	基準円直径 Reference Diameter <i>d</i>	歯先円直径 Outside Diameter <i>da</i>	形 Type	歯幅 Face Width <i>b</i>	穴径 Bore Diameter <i>da(H7)</i>	ハブ外径 Hub Diameter <i>dh</i>	ハブ長さ Hub Projection <i>lh</i>	全長 Overall Length <i>l</i>	キミぞ Key Way <i>b2 × t2</i>	ねじ Set Screw		リム内径 Dimension of Rim <i>di</i>	ウェブ厚さ Thickness of Web <i>bw</i>	重量 Weight <i>W(kg)</i>
											<i>M</i>	<i>ls</i>			
S2S 64A - 1220F	64	φ128	φ132	A1	12	φ20	-	-	12	-	-	-	-	-	1.18
S2S 64A = 1225	64	φ128	φ132	A2	12	φ25	φ50	-	12	8 × 3.3	-	-	φ110	6	0.85
S2S 64A - 2018F	64	φ128	φ132	A1	20	φ18	-	-	20	-	-	-	-	-	1.98
S2S 64A = 2020	64	φ128	φ132	A2	20	φ20	φ40	-	20	6 × 2.8	-	-	φ110	10	1.36
S2S 64A = 2025	64	φ128	φ132	A2	20	φ25	φ50	-	20	8 × 3.3	-	-	φ110	10	1.39
S2S 64B - 1216	64	φ128	φ132	B1	12	φ16	φ50	10	22	-	-	-	-	-	1.33
S2S 64B # 1220	64	φ128	φ132	B3	12	φ20	φ50	10	22	6 × 2.8	M5	5	φ110	6	0.97
S2S 64B - 2018	64	φ128	φ132	B1	20	φ18	φ60	10	30	-	-	-	-	-	2.18
S2S 64B # 2020	64	φ128	φ132	B3	20	φ20	φ60	10	30	6 × 2.8	M5	5	φ110	10	1.68
S2S 64B # 2025	64	φ128	φ132	B3	20	φ25	φ60	10	30	8 × 3.3	M6	5	φ110	10	1.63
S2S 65A - 1218F	65	φ130	φ134	A1	12	φ18	-	-	12	-	-	-	-	-	1.23
S2S 65A - 2020F	65	φ130	φ134	A1	20	φ20	-	-	20	-	-	-	-	-	2.04
S2S 65B - 1216	65	φ130	φ134	B1	12	φ16	φ60	10	22	-	-	-	-	-	1.44
S2S 65B - 2018	65	φ130	φ134	B1	20	φ18	φ70	10	30	-	-	-	-	-	2.33

【=】 (イコール) にはキマ材が付いております。【=】: Gear with key way / with key

【#】 (シャープ) にはキマ材とセットスクリューが付いております。【#】: Gear with key way and threaded hole / with key and screw.

許容伝達動力表 曲げ強さ (kW)

Allowable transfer capability table (kW) Bending Strength

歯数 <i>z</i>	歯幅 <i>b</i>	回転速度 (min ⁻¹) revolution/min							回転速度 (min ⁻¹) revolution/min
		10	100	200	400	800	1,200	1,500	
64	12	0.17	1.72	3.27	5.50	9.75	13.77	-	100
64	20	0.29	2.87	5.46	9.16	16.25	22.95	-	164.25
65	12	0.18	1.75	3.33	5.57	9.91	14.02	-	274.07
65	20	0.29	2.92	5.54	9.29	16.52	23.37	-	167.12
									278.85

The above numerical values are equivalent to JGMA formulas as reference only.

動力の換算式は P26 をご参照ください。Please refer to the conversion formulas of power on page P26.

平歯車 SPUR GEARS

モジュール
MODULE

2

圧力角 20° (並歯) 歯数 70 ~ 72

20° PRESSURE ANGLE FULL DEPTH TOOTH Z 70 to Z 72

JIS B 1702-1 (ISO) 8級 (高周波焼入品: 9級)
System of accuracy: JIS B 1702-1(ISO) class 8
(Induction hardened products: class 9)



御注文には必ず“フルネームで商品記号”を明記してください。
Please refer to the catalogue reference while ordering.

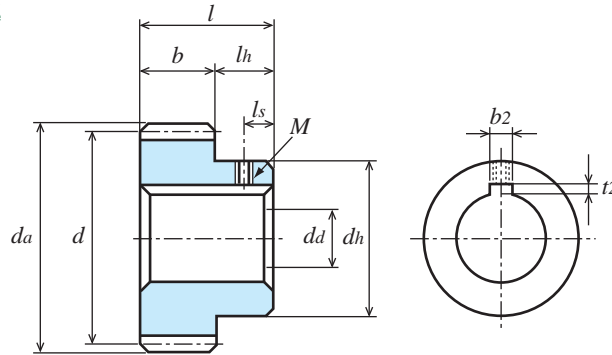

B1形
TYPE B1

S45C 機械構造用炭素鋼 (JIS G 4051) Material: Carbon Steel (ISO C45)

単位: mm
Dimensions: mm

商品記号 Catalogue Number	歯数 Number of Teeth z	基準円直径 Reference Diameter d	歯先円直径 Outside Diameter da	形 Type	歯幅 Face Width b	穴径 Bore Diameter da(H7)	ハブ外径 Hub Diameter dh	ハブ長さ Hub Projection lh	全長 Overall Length l	キミぞ Key Way b ₂ × t ₂	ねじ Set Screw		リム内径 Dimension of Rim di	ウエブ厚さ Thickness of Web bw	重量 Weight W(kg)
											M	ls			
S2S 70A - 1220F	70	φ140	φ144	A1	12	φ20	-	-	12	-	-	-	-	1.42	
S2S 70A - 2018F	70	φ140	φ144	A1	20	φ18	-	-	20	-	-	-	-	2.38	
S2S 70B - 1216	70	φ140	φ144	B1	12	φ16	φ60	10	22	-	-	-	-	1.64	
● S2S 70BF - 2015	70	φ140	φ144	B1	20	φ15	φ100	20	40	-	-	-	-	3.59	
● S2S 70B - 2015H	70	φ140	φ144	B1	20	φ15(H※)	φ100	20	40	-	-	-	-	3.59	
S2S 70B - 2018	70	φ140	φ144	B1	20	φ18	φ70	10	30	-	-	-	-	2.66	
S2S 72A - 1220F	72	φ144	φ148	A1	12	φ20	-	-	12	-	-	-	-	1.51	
S2S 72A = 1225	72	φ144	φ148	A2	12	φ25	φ50	-	12	8 × 3.3	-	φ126	6	1.01	
S2S 72A - 2018F	72	φ144	φ148	A1	20	φ18	-	-	20	-	-	-	-	2.52	
S2S 72A = 2025	72	φ144	φ148	A2	20	φ25	φ50	-	20	8 × 3.3	-	φ126	10	1.70	
S2S 72B - 1218	72	φ144	φ148	B1	12	φ18	φ50	10	22	-	-	-	-	1.65	
S2S 72B # 1220	72	φ144	φ148	B3	12	φ20	φ50	10	22	6 × 2.8	M5	5	φ126	6	1.15
S2S 72B - 2020	72	φ144	φ148	B1	20	φ20	φ60	10	30	-	-	-	-	2.71	
S2S 72B # 2025	72	φ144	φ148	B3	20	φ25	φ60	10	30	8 × 3.3	M6	5	φ126	10	1.94
S2S 72B # 2030	72	φ144	φ148	B3	20	φ30	φ60	10	30	8 × 3.3	M6	5	φ126	10	1.89

●の商品は新商品です。Products with ● marks are new item.

【=】(イコール)にはキー材が付いております。【=】: Gear with key way / with key

【#】(シャープ)にはキー材とセットスクリューが付いております。【#】: Gear with key way and threaded hole / with key and screw.

カタログ記号の末尾に【H】を付した商品は歯部高周波焼入済です。Gear tooth surface completed with induction hardening, Hardness HRC47 to 53.

※ 歯部高周波焼入後の穴修正は行っていません。Bore correcting after induction hardening is not completed.

追加加工の際は、追加加工時の注意をご参照ください。Please refer to Precaution for additional process when additional process.

許容伝達動力表 曲げ強さ (kW)

Allowable transfer capability table (kW) Bending Strength

歯数 z	歯幅 b	焼入 H	回転速度 (min ⁻¹) revolution/min						
			10	100	200	400	800	1,200	1,500
70	12	-	0.19	1.91	3.58	5.93	10.71	15.31	-
70	20	-	0.320	3.170	5.920	9.820	17.740	25.350	-
70	20	○	0.336	3.359	6.316	10.633	19.705	29.557	-
72	12	-	0.20	1.98	3.67	6.08	11.03	15.82	-
72	20	-	0.33	3.30	6.12	10.13	18.38	26.37	-

The above references are JGMA standard.

動力の換算式は P26 をご参照ください。Please refer to the conversion formulas of power on page P26.

許容伝達動力表 歯面強さ (kW)

Allowable transfer capability table (kW) Surface Durability

回転速度 (min ⁻¹) revolution/min						
10	100	200	400	800	1,200	1,500
-	-	-	-	-	-	-
0.039	0.390	0.750	1.290	2.510	3.810	-
0.171	1.893	3.670	6.370	12.168	18.579	-
-	-	-	-	-	-	-
-	-	-	-	-	-	-

目次
CONTENTS

インフォメーション
INFORMATION

ギヤボックス
GEAR BOXES

ノーバッキングギヤ
ANTI BACKLASH SPUR GEARS

歯研削歯車
GROUND SPUR GEARS

歯研削歯車
SPUR GEARS

内歯車
INTERNAL GEARS

歯研削ラック
GROUND RACKS

ラック
RACKS

ハニカムギヤ
HELIICAL GEARS AND SCREW GEARS

ウォーム
WORMS AND WORM WHEELS

かさ歯車
BEVEL GEARS

スプロケット
SPROCKETS

技術データ
REFERENCE DATA

平歯車

SPUR GEARS

モジュール
MODULE

2

圧力角 20° (並歯) 歯数 75 80

20° PRESSURE ANGLE FULL DEPTH TOOTH Z 75 to 80

JIS B 1702-1 (ISO) 8級 (高周波焼入品: 9級)
System of accuracy: JIS B 1702-1(ISO) class 8
(Induction hardened products: class 9)



New 仕様変更 省スペース・軽量化、締結加工不要。
Specification change Space-saving and weight saving.
Additional machining on tightening is not necessary.

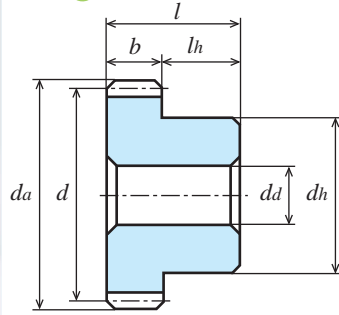

B1形
TYPE B1

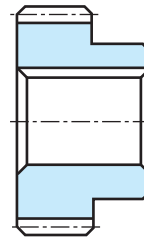

B1形
TYPE B1

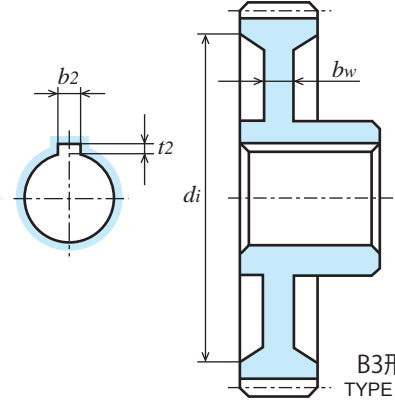

B3形
TYPE B3

S45C 機械構造用炭素鋼 (JIS G 4051)

Material: Carbon Steel (ISO C45)

単位: mm
Dimensions: mm

商品記号 Catalogue Number	歯数 Number of Teeth z	基準円直径 Reference Diameter d	歯先円直径 Outside Diameter da	形 Type	歯幅 Face Width b	穴径 Bore Diameter da(H7)	ハブ外径 Hub Diameter dh	ハブ長さ Hub Projection lh	全長 Overall Length l	キミぞ Key Way b2 × t2	ねじ Set Screw		リム内径 Dimension of Rim di	ウェブ厚さ Thickness of Web bw	重量 Weight W(kg)
											M	ls			
S2S 75A - 1218F	75	φ150	φ154	A1	12	φ18	-	-	12	-	-	-	-	-	1.64
S2S 75A - 2020F	75	φ150	φ154	A1	20	φ20	-	-	20	-	-	-	-	-	2.73
S2S 75B - 1218	75	φ150	φ154	B1	12	φ18	φ 60	10	22	-	-	-	-	-	1.84
S2S 75B - 2020	75	φ150	φ154	B1	20	φ20	φ 70	10	30	-	-	-	-	-	3.00
S2S 80A - 1220F	80	φ160	φ164	A1	12	φ20	-	-	12	-	-	-	-	-	1.86
S2S 80A = 1225	80	φ160	φ164	A2	12	φ25	φ 50	-	12	8 × 3.3	-	-	φ142	6	1.21
S2S 80A - 2018F	80	φ160	φ164	A1	20	φ18	-	-	20	-	-	-	-	-	3.12
S2S 80A = 2025	80	φ160	φ164	A2	20	φ25	φ 50	-	20	8 × 3.3	-	-	φ142	10	2.03
S2S 80A = 2030	80	φ160	φ164	A2	20	φ30	φ 60	-	20	8 × 3.3	-	-	φ142	10	2.07
S2S 80B - 1218	80	φ160	φ164	B1	12	φ18	φ 50	10	22	-	-	-	-	-	2.01
S2S 80B # 1220	80	φ160	φ164	B3	12	φ20	φ 50	10	22	6 × 2.8	M5	5	φ142	6	1.35
S2S 80B # 1225	80	φ160	φ164	B3	12	φ25	φ 50	10	22	8 × 3.3	M6	5	φ142	6	1.32
S2S 80BF - 2015	80	φ160	φ164	B1	20	φ15	φ115	20	40	-	-	-	-	-	4.72
S2S 80B - 2015H	80	φ160	φ164	B1	20	φ15(H※)	φ115	20	40	-	-	-	-	-	4.72
S2S 80B - 2020	80	φ160	φ164	B1	20	φ20	φ 60	10	30	-	-	-	-	-	3.31
S2S 80B # 2025	80	φ160	φ164	B3	20	φ25	φ 60	10	30	8 × 3.3	M6	5	φ142	10	2.28
S2S 80B # 2030	80	φ160	φ164	B3	20	φ30	φ 60	10	30	8 × 3.3	M6	5	φ142	10	2.23

●の商品は新商品です。Products with ● marks are new item.

【=】(イコール)にはキー材が付いております。 [=]: Gear with key way / with key

【#】(シャープ)にはキー材とセットスクリューが付いております。 [#]: Gear with key way and threaded hole / with key and screw.

カタログ記号の末尾に【H】を付した商品は歯部高周波焼入済です。 Gear tooth surface completed with induction hardening, Hardness HRC47 to 53.

※ 歯部高周波焼入後の穴修正は行っていません。 Bore correcting after induction hardening is not completed.

追加加工の際は、追加加工時の注意をご参照ください。 Please refer to Precaution for additional process when additional process.

許容伝達動力表 曲げ強さ (kW)

Allowable transfer capability table (kW) Bending Strength

歯数 z	歯幅 b	焼入 H	回転速度 (min ⁻¹) revolution/min						
			10	100	200	400	800	1,200	1,500
75	12	-	0.21	2.07	3.82	6.35	11.50	16.59	-
75	20	-	0.35	3.46	6.37	10.58	19.14	27.65	-
80	12	-	0.22	2.24	4.06	6.79	12.28	-	-
80	20	-	0.370	3.700	6.720	11.230	20.310	-	-
80	20	○	0.392	3.921	7.181	12.171	23.005	-	-

The above references are JGMA standard.

動力の換算式は P26 をご参照ください。 Please refer to the conversion fomulas of power on page P26.

許容伝達動力表 歯面強さ (kW)

Allowable transfer capability table (kW) Surface Durability

回転速度 (min ⁻¹) revolution/min						
10	100	200	400	800	1,200	1,500
-	-	-	-	-	-	-
-	-	-	-	-	-	-
-	-	-	-	-	-	-
0.051	0.520	0.970	1.690	3.330	-	-
0.226	2.505	4.728	8.261	16.096	-	-

平歯車 SPUR GEARS

モジュール
MODULE

2

圧力角 20° (並歯) 歯数 85 95

20° PRESSURE ANGLE FULL DEPTH TOOTH Z 85 to Z 95

JIS B 1702-1 (ISO) 8級 (高周波焼入品: 9級)
System of accuracy: JIS B 1702-1(ISO) class 8
(Induction hardened products: class 9)



御注文には必ず“フルネームで商品記号”を明記してください。

Please refer to the catalogue reference while ordering.

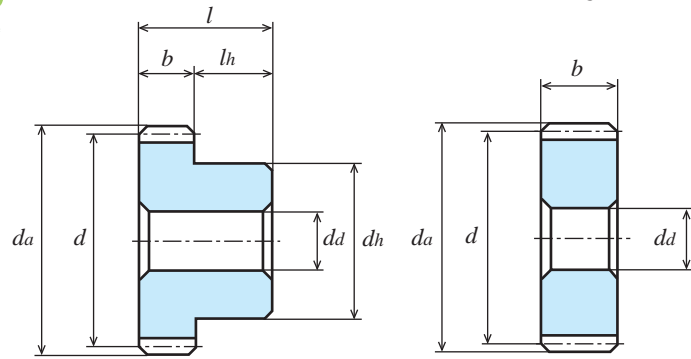

B1形
TYPE B1

A1形
TYPE A1

S45C 機械構造用炭素鋼 (JIS G 4051)

Material: Carbon Steel (ISO C45)

単位: mm
Dimensions: mm

商品記号 Catalogue Number	歯数 Number of Teeth z	基準円直径 Reference Diameter d	歯先円直径 Tip Diameter da	形 Type	歯幅 Face Width b	穴径 Bore Diameter da(H7)	ハブ外径 Hub Diameter dh	ハブ長さ Hub Projection lh	全長 Overall Length l	キミぞ Key Way b ₂ × t ₂	リム内径 Dimension of Rim di	ウェブ厚さ Thickness of Web bw	重量 Weight W(kg)
S2S 85A - 1218F	85	φ170	φ174	A1	12	φ18	-	-	12	-	-	-	2.11
S2S 85A - 2020F	85	φ170	φ174	A1	20	φ20	-	-	20	-	-	-	3.51
S2S 85B - 1218	85	φ170	φ174	B1	12	φ18	φ60	10	22	-	-	-	2.32
S2S 85B - 2020	85	φ170	φ174	B1	20	φ20	φ70	10	30	-	-	-	3.79
S2S 90A - 1218F	90	φ180	φ184	A1	12	φ18	-	-	12	-	-	-	2.37
S2S 90A - 2020F	90	φ180	φ184	A1	20	φ20	-	-	20	-	-	-	3.95
S2S 90B - 1218	90	φ180	φ184	B1	12	φ18	φ60	10	22	-	-	-	2.58
● S2S 90BF - 2015	90	φ180	φ184	B1	20	φ15	φ130	20	40	-	-	-	6.01
● S2S 90B - 2015H	90	φ180	φ184	B1	20	φ15(H※)	φ130	20	40	-	-	-	6.01
S2S 90B - 2020	90	φ180	φ184	B1	20	φ20	φ80	10	30	-	-	-	4.32
S2S 95A - 1218F	95	φ190	φ194	A1	12	φ18	-	-	12	-	-	-	2.65
S2S 95A - 2020F	95	φ190	φ194	A1	20	φ20	-	-	20	-	-	-	4.40
S2S 95B - 1218	95	φ190	φ194	B1	12	φ18	φ60	10	22	-	-	-	2.85
S2S 95B - 2020	95	φ190	φ194	B1	20	φ20	φ80	10	30	-	-	-	4.78

● の商品は新商品です。Products with ● marks are new item.

カタログ記号の末尾に【H】を付した商品は歯部高周波焼入済です。Gear tooth surface completed with induction hardening, Hardness HRC47 to 53.

※ 歯部高周波焼入後の穴修正は行っていません。Bore correcting after induction hardening is not completed.

追加加工の際は、追加加工時の注意をご参照ください。Please refer to Precaution for additional process when additional process.

許容伝達動力表 曲げ強さ (kW)

Allowable transfer capability table (kW) Bending Strength

歯数 z	歯幅 b	焼入 H	回転速度 (min ⁻¹) revolution/min						
			10	100	200	400	800	1,200	1,500
85	12	-	0.24	2.39	4.29	7.21	13.02	-	-
85	20	-	0.40	3.99	7.14	12.02	21.71	-	-
90	12	-	0.26	2.56	4.51	7.64	13.77	-	-
90	20	-	0.420	4.230	7.460	12.630	22.780	-	-
90	20	○	0.448	4.481	7.997	13.707	26.290	-	-
95	12	-	0.27	2.72	4.73	8.06	14.51	-	-
95	20	-	0.45	4.53	7.89	13.43	24.18	-	-

The above references are JGMA standard.

動力の換算式は P26 をご参照ください。Please refer to the conversion formulas of power on page P26.

許容伝達動力表 歯面強さ (kW)

Allowable transfer capability table (kW) Surface Durability

回転速度 (min ⁻¹) revolution/min						
10	100	200	400	800	1,200	1,500
-	-	-	-	-	-	-
-	-	-	-	-	-	-
-	-	-	-	-	-	-
0.066	0.670	1.210	2.150	4.260	-	-
0.189	3.206	5.897	10.419	20.601	-	-
-	-	-	-	-	-	-
-	-	-	-	-	-	-

目次
CONTENTS
インフォメーション
INFORMATION
ギヤボックス
GEAR BOXES
ノーバッキングギヤ
ANTI BACKLASH SPUR GEARS
歯研削歯車
GROUND SPUR GEARS
歯研削歯車
SPUR GEARS
内歯車
INTERNAL GEARS
歯研削ラック
GROUND RACKS
ラック
RACKS
（リ）カハ・スクリューギヤ
HELICAL GEARS AND SCREW GEARS
ワーム・ワームホイール
WORMS AND WORM WHEELS
かさ歯車
BEVEL GEARS
スプロケット
SPROCKETS
技術データ
REFERENCE DATA

平歯車 SPUR GEARS

モジュール
MODULE

2

圧力角 20° (並歯) 歯数 100

20° PRESSURE ANGLE FULL DEPTH TOOTH Z 100

JIS B 1702-1 (ISO) 8級 (高周波焼入品: 9級)
System of accuracy: JIS B 1702-1(ISO) class 8
(Induction hardened products: class 9)



仕様変更 省スペース・軽量化、締結加工不要。

Specification change Space-saving and weight saving.
Additional machining on tightening is not necessary.

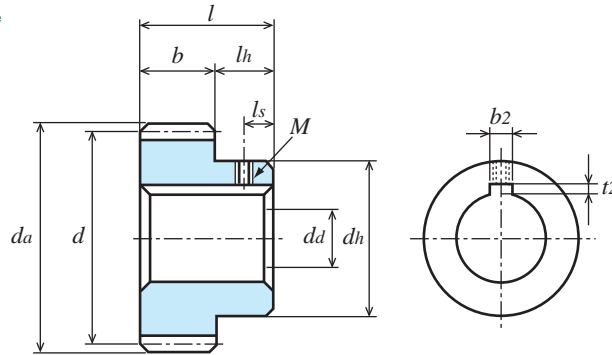

B1形
TYPE B1

S45C 機械構造用炭素鋼 (JIS G 4051)

Material: Carbon Steel (ISO C45)

単位: mm
Dimensions: mm

商品記号 Catalogue Number	歯数 Number of Teeth z	基準円直径 Reference Diameter d	歯先円直径 Outside Diameter da	形 Type	歯幅 Face Width b	穴径 Bore Diameter da(H7)	ハブ外径 Hub Diameter dh	ハブ長さ Hub Projection lh	全長 Overall Length l	キミぞ Key Way b2 × t2	ねじ Set Screw		リム内径 Dimension of Rim di	ウエブ厚さ Thickness of Web bw	重量 Weight W(kg)
											M	ls			
S2S 100A - 1220F	100	φ200	φ204	A1	12	φ20	-	-	12	-	-	-	-	-	2.93
S2S 100A = 1225	100	φ200	φ204	A2	12	φ25	φ 50	-	12	8 × 3.3	-	-	φ182	6	1.80
S2S 100A - 2018F	100	φ200	φ204	A1	20	φ18	-	-	20	-	-	-	-	-	4.89
S2S 100A = 2025	100	φ200	φ204	A2	20	φ25	φ 50	-	20	8 × 3.3	-	-	φ182	10	3.03
S2S 100A = 2030	100	φ200	φ204	A2	20	φ30	φ 60	-	20	8 × 3.3	-	-	φ182	10	3.06
S2S 100B - 1218	100	φ200	φ204	B1	12	φ18	φ 50	10	22	-	-	-	-	-	3.07
S2S 100B # 1220	100	φ200	φ204	B3	12	φ20	φ 50	10	22	6 × 2.8	M5	5	φ182	6	1.95
S2S 100B # 1225	100	φ200	φ204	B3	12	φ25	φ 50	10	22	8 × 3.3	M6	5	φ182	6	1.91
S2S 100BF - 2015	100	φ200	φ204	B1	20	φ15	φ140	20	40	-	-	-	-	-	7.28
S2S 100B - 2015H	100	φ200	φ204	B1	20	φ15(H※)	φ140	20	40	-	-	-	-	-	7.28
S2S 100B - 2020	100	φ200	φ204	B1	20	φ20	φ 60	10	30	-	-	-	-	-	5.08
S2S 100B # 2025	100	φ200	φ204	B3	20	φ25	φ 60	10	30	8 × 3.3	M6	5	φ182	10	3.28
S2S 100B # 2030	100	φ200	φ204	B3	20	φ30	φ 60	10	30	8 × 3.3	M6	5	φ182	10	3.22

●の商品は新商品です。Products with ● marks are new item.

[=] (イコール) にはキー材が付いております。 [=]: Gear with key way / with key

[#] (シャープ) にはキー材とセットスクリューが付いております。 [#]: Gear with key way and Threaded hole / with key and screw.

カタログ記号の末尾に【H】を付した商品は歯部高周波焼入済です。Gear tooth surface completed with induction hardening, Hardness HRC47 to 53.

※
歯部高周波焼入後の穴修正は行っていません。Bore correcting after induction hardening is not completed.

追加加工の際は、追加加工時の注意をご参照ください。Please refer to Precaution for additional process when additional process.

許容伝達動力表 曲げ強さ (kW)

Allowable transfer capability table (kW) Bending Strength

歯数 z	歯幅 b	焼入 H	回転速度 (min ⁻¹) revolution/min						
			10	100	200	400	800	1,200	1,500
100	12	-	0.29	2.86	4.95	8.48	15.36	-	-
100	20	-	0.480	4.730	8.180	14.010	25.390	-	-
100	20	○	0.505	5.015	8.784	15.217	29.611	-	-

The above references are JGMA standard.

動力の換算式はP26をご参照ください。Please refer to the conversion formulas of power on page P26.

許容伝達動力表 歯面強さ (kW)

Allowable transfer capability table (kW) Surface Durability

回転速度 (min ⁻¹) revolution/min							
10	100	200	400	800	1,200	1,500	
-	-	-	-	-	-	-	-
0.082	0.830	1.480	2.660	5.340	-	-	-
0.361	3.972	7.171	12.807	25.689	-	-	-

Memo

目次
CONTENTS

インフォメーション
INFORMATION

ギヤボックス
GEAR BOXES

ノーバッキングギヤ
ANTI BACKLASH SPUR GEARS

歯
GROUND SPUR GEARS

歯
SPUR GEARS

内歯
INTERNAL GEARS

歯
GROUND RACKS

ラック
RACKS

へりかた・スクリューギヤ
HELICAL GEARS AND SCREW GEARS

ワーム・ワームホイール
WORMS AND WORM WHEELS

かみ歯
BEVEL GEARS

スプロケット
SPROCKETS

技術資料
REFERENCE DATA

平歯車 SPUR GEARS

モジュール **2.5** 圧力角 20° (並歯)
MODULE 2.5 20° PRESSURE ANGLE FULL DEPTH TOOTH

JIS B 1702-1 (ISO) 9~10 級
System of accuracy : JIS B 1702-1(ISO) class 9-10



New 仕様変更 省スペース・軽量化。
Specification change Space-saving and weight saving.

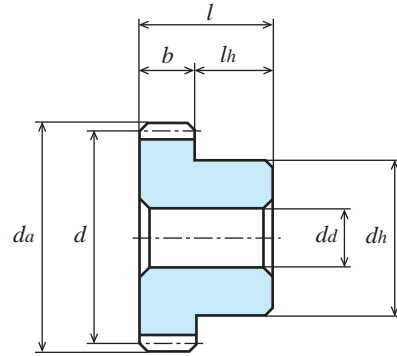

B1形
TYPE B1

ポリアセタール (黒色)
Material : Poly Acetal (Black)

単位 : mm
Dimensions : mm

商品記号 Catalogue Number	歯数 Number of Teeth <i>z</i>	基準円直径 Reference Diameter <i>d</i>	歯先円直径 Tip Diameter <i>da</i>	形 Type	歯幅 Face Width <i>b</i>	穴径 Bore Diameter <i>dd</i>	ハブ外径 Hub Diameter <i>dh</i>	ハブ長さ Hub Projection <i>lh</i>	全長 Overall Length <i>l</i>	重量 Weight <i>W(g)</i>
▲ S2.5D 14B - 2812N	14	φ35	φ40	B1	28	φ12	φ28	12	40	42.0
▲ S2.5D 15B - 2812N	15	φ37.5	φ42.5	B1	28	φ12	φ30	12	40	49.2
▲ S2.5D 16B - 2812N	16	φ40	φ45	B1	28	φ12	φ32	12	40	56.8
▲ S2.5D 18B - 2812N	18	φ45	φ50	B1	28	φ12	φ36	12	40	73.6
▲ S2.5D 20B - 2814N	20	φ50	φ55	B1	28	φ14	φ40	12	40	90.1
▲ S2.5D 24B - 2816N	24	φ60	φ65	B1	28	φ16	φ42	12	40	123.7
▲ S2.5D 25B - 2816N	25	φ62.5	φ67.5	B1	28	φ16	φ42	12	40	133.2
▲ S2.5D 28B - 2816N	28	φ70	φ75	B1	28	φ16	φ46	12	40	168.7
▲ S2.5D 30B - 2818N	30	φ75	φ80	B1	28	φ18	φ46	12	40	188.2
▲ S2.5D 32B - 2818N	32	φ80	φ85	B1	28	φ18	φ50	12	40	217.3
▲ S2.5D 35B - 2818N	35	φ87.5	φ92.5	B1	28	φ18	φ60	12	40	270.9
▲ S2.5D 36B - 2818N	36	φ90	φ95	B1	28	φ18	φ60	12	40	284.7

▲の商品は2017年5月20日をもってカタログ商品(規格品)としての生産を中止とします。米国・EU市場の食品接触用途・規制に適合した青 POM® ギヤシリーズをご利用ください。Products with ▲ mark will be terminated with effective 20th May 2017. Alternative products are indicated on separate catalogue of Blue Poly Acetal gears which adapted to relevant regulations for the food industries in the US and EU markets.

許容伝達動力表 曲げ強さ (W)

Allowable transfer capability table (W) Bending Strength

商品記号 Catalogue Numbers	回転速度 (min ⁻¹) revolution/min						
	10	100	200	400	800	1,200	1,500
S2.5D 14B - 2812N	4.86	48.56	97.02	193.64	385.64	576.02	716.18
S2.5D 15B - 2812N	5.21	52.03	103.94	207.40	412.94	616.60	765.14
S2.5D 16B - 2812N	5.56	55.49	110.85	221.16	440.20	657.03	813.81
S2.5D 18B - 2812N	6.25	62.42	124.67	248.66	494.63	735.80	910.28
S2.5D 20B - 2814N	6.94	69.34	138.48	276.12	548.92	813.81	1,005.58
S2.5D 24B - 2816N	8.33	83.19	166.07	330.95	657.03	967.60	1,192.67
S2.5D 25B - 2816N	8.68	86.65	172.97	344.63	683.37	1,005.58	1,238.71
S2.5D 28B - 2816N	9.72	97.02	193.64	385.64	761.89	1,118.39	1,370.93
S2.5D 30B - 2818N	10.41	103.94	207.40	412.94	813.81	1,192.67	1,456.58
S2.5D 32B - 2818N	11.11	110.85	221.16	440.20	865.41	1,265.99	1,540.60
S2.5D 35B - 2818N	12.15	121.21	241.79	481.03	942.17	1,370.93	1,663.56
S2.5D 36B - 2818N	12.50	124.67	248.66	494.63	967.60	1,405.39	1,703.72

The above numerical values are Lewis formulas as reference only.

動力の換算式は P26 をご参照ください。

Please refer to the conversion formulas of power on page P26.

平歯車

SPUR GEARS

モジュール **2.5** 圧力角 20° (並歯)
 MODULE 2.5 20° PRESSURE ANGLE FULL DEPTH TOOTH

JIS B 1702-1 (ISO) 9~10 級
 System of accuracy : JIS B 1702-1(ISO) class 9-10



御注文には必ず“フルネームで商品記号”を明記してください。
 Please refer to the catalogue reference while ordering.

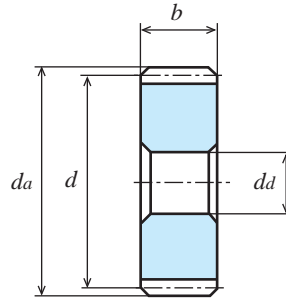

A1形
TYPE A1

ポリアセタール (黒色) Material : Poly Acetal (Black)

単位 : mm
Dimensions : mm

商品記号 Catalogue Number	歯数 Number of Teeth <i>z</i>	基準円直径 Reference Diameter <i>d</i>	歯先円直径 Tip Diameter <i>da</i>	形 Type	歯幅 Face Width <i>b</i>	穴径 Bore Diameter <i>da</i>	ハブ外径 Hub Diameter <i>dh</i>	ハブ長さ Hub Projection <i>lh</i>	全長 Overall Length <i>l</i>	重量 Weight <i>W(g)</i>
▲ S2.5D 40A - 2818	40	φ100	φ105	A1	28	φ18	-	-	28	300.0
▲ S2.5D 45A - 2818	45	φ112.5	φ117.5	A1	28	φ18	-	-	28	382.4
▲ S2.5D 48A - 2818	48	φ120	φ125	A1	28	φ18	-	-	28	436.5
▲ S2.5D 50A - 2818	50	φ125	φ130	A1	28	φ18	-	-	28	474.4
▲ S2.5D 56A - 2818	56	φ140	φ145	A1	28	φ18	-	-	28	597.7
▲ S2.5D 60A - 2818	60	φ150	φ155	A1	28	φ18	-	-	28	687.6
▲ S2.5D 64A - 2818	64	φ160	φ165	A1	28	φ18	-	-	28	783.7
▲ S2.5D 70A - 2818	70	φ175	φ180	A1	28	φ18	-	-	28	939.6
▲ S2.5D 72A - 2818	72	φ180	φ185	A1	28	φ18	-	-	28	994.6
▲ S2.5D 80A - 2818	80	φ200	φ205	A1	28	φ18	-	-	28	1,230.0

▲の商品は2017年5月20日をもってカタログ商品(規格品)としての生産を中止とします。米国・EU市場の食品接触用途・規制に適合した青 POM® ギヤシリーズをご利用ください。Products with ▲ mark will be terminated with effective 20th May 2017. Alternative products are indicated on separate catalogue of Blue Poly Acetal gears which adapted to relevant regulations for the food industries in the US and EU markets.

許容伝達動力表 曲げ強さ (W)

Allowable transfer capability table (W) Bending Strength

商品記号 Catalogue Numbers	回転速度 (min ⁻¹) revolution/min						
	10	100	200	400	800	1,200	1,500
S2.5D 40A - 2818	13.89	138.48	276.12	548.92	1,068.46	1,540.60	1,853.98
S2.5D 45A - 2818	15.62	155.73	310.40	616.60	1,192.67	1,703.72	2,019.98
S2.5D 48A - 2818	16.66	166.07	330.95	657.03	1,265.99	1,797.77	2,112.57
S2.5D 50A - 2818	17.36	172.97	344.63	683.37	1,312.92	1,853.98	2,171.37
S2.5D 56A - 2818	19.44	193.64	385.64	761.89	1,450.93	2,013.62	-
S2.5D 60A - 2818	20.82	207.40	412.94	813.81	1,540.60	2,112.57	-
S2.5D 64A - 2818	22.21	221.16	440.20	865.41	1,628.41	-	-
S2.5D 70A - 2818	24.29	241.79	481.03	942.17	1,756.64	-	-
S2.5D 72A - 2818	24.99	248.66	494.63	967.60	1,797.77	-	-
S2.5D 80A - 2818	27.76	276.12	548.92	1,068.46	1,944.33	-	-

The above numerical values are Lewis formulas as reference only.

動力の換算式は P26 をご参照ください。

Please refer to the conversion formulas of power on page P26.

目次
CONTENTS

インフォメーション
INFORMATION

ギヤボックス
GEAR BOXES

ノーバッキングギヤ
ANTI BACKLASH SPUR GEARS

歯研平歯車
GROUND SPUR GEARS

平歯車
SPUR GEARS

内歯車
INTERNAL GEARS

歯研ラック
GROUND RACKS

ラック
RACKS

へリカル・スクリューギヤ
HELICAL GEARS AND SCREW GEARS

ウォーム・ウォームギヤ
WORMS AND WORM GEARS

かさ歯車
BEVEL GEARS

スプロケット
SPROCKETS

技術資料
REFERENCE DATA

平歯車 SPUR GEARS

モジュール **2.5** 圧力角 20° (並歯) 歯数 8 ~ 14
 MODULE 20° PRESSURE ANGLE FULL DEPTH TOOTH Z 8 to Z 14

JIS B 1702-1 (ISO) 8級~9級
 System of accuracy : JIS B 1702-1(ISO) class 8-9



New 仕様変更 省スペース・軽量化。
 Specification change Space-saving and weight saving.

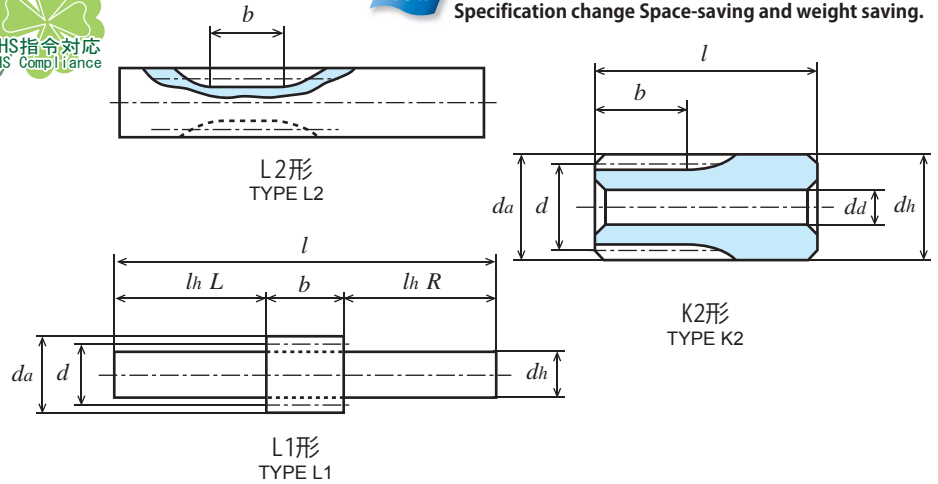

S45C 機械構造用炭素鋼 (JIS G 4051) *印を付した商品は転位歯車です。転位係数 x は 0.5 です。
 Material : Carbon Steel (ISO C45) * mark has been profile shifted gears. (Rack shift coefficient $x = 0.5$)

単位 : mm
 Dimensions : mm

商品記号 Catalogue Number	歯数 Number of Teeth z	基準円直径 Reference Diameter d	歯先円直径 Tip Diameter da	形 Type	歯幅 Face Width b	穴径 Bore Diameter $da(H7)$	ハブ外径 Hub Diameter d_h	ハブ長さ Hub Projection l_h	全長 Overall Length l	重量 Weight $W(g)$
S2.5S 8L - 2815	8	*	$\phi 26.59$	L1	28	-	$\phi 15(h9)$	L40 R80	148	235.5
S2.5S 8L - 2826F	8	*	$\phi 26.59$	L2	28	-	$\phi 26.59$	L40 R80	148	592.1
S2.5S 10L - 2820	10	*	$\phi 31.66$	L1	28	-	$\phi 20(h9)$	L40 R80	148	403.8
S2.5S 10L - 2831F	10	*	$\phi 31.66$	L2	28	-	$\phi 31.66$	L40 R80	148	849.5
S2.5S 12K - 2812	12	$\phi 30$	$\phi 35$	K2	28	$\phi 12(H8)$	$\phi 35$	32	60	343.8
S2.5S 14A - 1612	14	$\phi 35$	$\phi 40$	A1	16	$\phi 12$	-	-	16	106.6
S2.5S 14A - 1812	14	$\phi 35$	$\phi 40$	A1	18	$\phi 12$	-	-	18	120.0
S2.5S 14A - 2512	14	$\phi 35$	$\phi 40$	A1	25	$\phi 12$	-	-	25	166.6
S2.5S 14A - 2812	14	$\phi 35$	$\phi 40$	A1	28	$\phi 12$	-	-	28	186.6
S2.5S 14B - 1612N	14	$\phi 35$	$\phi 40$	B1	16	$\phi 12$	$\phi 27$	12	28	150.0
S2.5S 14B - 1812N	14	$\phi 35$	$\phi 40$	B1	18	$\phi 12$	$\phi 28$	12	30	167.4
S2.5S 14B - 2512N	14	$\phi 35$	$\phi 40$	B1	25	$\phi 12(H8)$	$\phi 27$	12	37	210.0
S2.5S 14B - 2812N	14	$\phi 35$	$\phi 40$	B1	28	$\phi 12(H8)$	$\phi 28$	12	40	234.1

許容伝達動力表 曲げ強さ (kW)

Allowable transfer capability table (W) Bending Strength

歯数 z	歯幅 b	回転速度 (min ⁻¹) revolution/min							回転速度 (min ⁻¹) revolution/min
		10	100	200	400	800	1,200	1,500	
8	28	0.046	0.46	0.93	1.87	3.74	5.31	6.33	100
10	28	0.064	0.64	1.29	2.58	5.07	7.02	8.29	43.92
12	28	0.059	0.59	1.18	2.37	4.57	6.29	7.40	61.11
14	16	0.044	0.44	0.88	1.77	3.30	4.50	5.25	56.34
14	18	0.049	0.49	0.99	1.99	3.72	5.06	5.91	42.01
14	25	0.069	0.69	1.38	2.76	5.17	7.03	8.21	46.79
14	28	0.077	0.77	1.55	3.10	5.79	7.88	9.20	65.89
									73.53

The above numerical values are equivalent to JGMA formulas as reference only.

動力の換算式は P26 をご参照ください。Please refer to the conversion fomulas of power on page P26.

平歯車

SPUR GEARS

モジュール **2.5** 圧力角 20° (並歯) 歯数 15 16
 MODULE 20° PRESSURE ANGLE FULL DEPTH TOOTH Z 15 to Z 16

JIS B 1702-1 (ISO) 8級
 System of accuracy: JIS B 1702-1(ISO) class 8



御注文には必ず“フルネームで商品記号”を明記してください。
 Please refer to the catalogue reference while ordering.

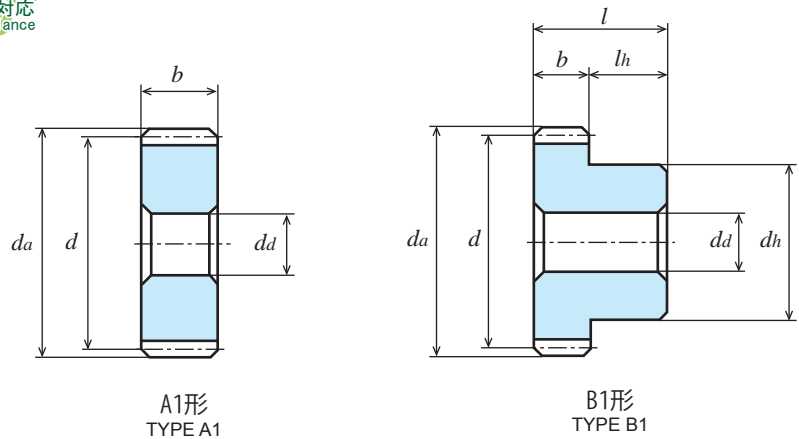

S45C 機械構造用炭素鋼 (JIS G 4051)

Material: Carbon Steel (ISO C45)

単位: mm
 Dimensions: mm

商品記号 Catalogue Number	歯数 Number of Teeth z	基準円直径 Reference Diameter d	歯先円直径 Tip Diameter da	形 Type	歯幅 Face Width b	穴径 Bore Diameter da(H7)	ハブ外径 Hub Diameter dh	ハブ長さ Hub Projection lh	全長 Overall Length l	重量 Weight W(g)
S2.5S 15A - 1612	15	φ37.5	φ42.5	A1	16	φ12	-	-	16	124.5
S2.5S 15A - 1812	15	φ37.5	φ42.5	A1	18	φ12	-	-	18	140.1
S2.5S 15A - 2512	15	φ37.5	φ42.5	A1	25	φ12	-	-	25	194.6
S2.5S 15A - 2812	15	φ37.5	φ42.5	A1	28	φ12	-	-	28	217.9
S2.5S 15B - 1612N	15	φ37.5	φ42.5	B1	16	φ12	φ30	12	28	280.6
S2.5S 15B - 1812N	15	φ37.5	φ42.5	B1	18	φ12	φ30	12	30	196.1
S2.5S 15B - 2512N	15	φ37.5	φ42.5	B1	25	φ12(H8)	φ30	12	37	250.7
S2.5S 15B - 2812N	15	φ37.5	φ42.5	B1	28	φ12(H8)	φ30	12	40	274.0
S2.5S 16A - 1612	16	φ40	φ45	A1	16	φ12	-	-	16	143.6
S2.5S 16A - 1812	16	φ40	φ45	A1	18	φ12	-	-	18	161.6
S2.5S 16A - 2512	16	φ40	φ45	A1	25	φ12	-	-	25	224.4
S2.5S 16A - 2812	16	φ40	φ45	A1	28	φ12	-	-	28	251.4
S2.5S 16B - 1612N	16	φ40	φ45	B1	16	φ12	φ32	12	28	208.9
S2.5S 16B - 1812N	16	φ40	φ45	B1	18	φ12	φ32	12	30	226.8
S2.5S 16B - 2512N	16	φ40	φ45	B1	25	φ12(H8)	φ32	12	37	289.7
S2.5S 16B - 2812N	16	φ40	φ45	B1	28	φ12(H8)	φ32	12	40	316.7

許容伝達動力表 曲げ強さ (kW)

Allowable transfer capability table (W) Bending Strength

T (N・m)

歯数 z	歯幅 b	回転速度 (min ⁻¹) revolution/min							回転速度 (min ⁻¹) revolution/min
		10	100	200	400	800	1,200	1,500	
15	16	0.049	0.49	0.99	1.98	3.65	4.94	5.75	46.79
15	18	0.055	0.55	1.11	2.23	4.11	5.56	6.47	52.52
15	25	0.077	0.78	1.55	3.10	5.71	7.73	9.00	74.48
15	28	0.087	0.87	1.74	3.47	6.40	8.66	10.08	83.08
16	16	0.055	0.55	1.10	2.20	3.99	5.38	6.31	52.52
16	18	0.061	0.61	1.23	2.47	4.49	6.05	7.10	58.25
16	25	0.086	0.86	1.72	3.44	6.25	8.41	9.87	82.12
16	28	0.096	0.96	1.93	3.85	7.00	9.42	11.06	91.67

KG規格は“並幅”(軽荷重用)と“広幅”(重荷重用)があります。ご用途に応じてお選び下さい。

KG STOCK GEARS has Wide-face width for Heavy load, and Standard-face width for Light load.

You are able to multiple choices for your suitable design from our wide range.

The above numerical values are equivalent to JGMA formulas as reference only.

動力の換算式は P26 をご参照ください。Please refer to the conversion fomulas of power on page P26.

目次
CONTENTS

インフォメーション
INFORMATION

ギヤボックス
GEAR BOXES

ノーバッキングギヤ
ANTI BACKLASH SPUR GEARS

歯研平歯車
GROUND SPUR GEARS

平歯車
SPUR GEARS

内歯車
INTERNAL GEARS

歯研ラック
GROUND RACKS

ラック
RACKS

ひかりスクリューギヤ
HELICAL GEARS AND SCREW GEARS

ウォーム・ウォームホイール
WORMS AND WORM WHEELS

かさ歯車
BEVEL GEARS

スプロケット
SPROCKETS

技術資料
REFERENCE DATA

平歯車 SPUR GEARS

モジュール **2.5** 圧力角 20° (並歯) 歯数 18
 MODULE 20° PRESSURE ANGLE FULL DEPTH TOOTH Z 18

JIS B 1702-1 (ISO) 8 級
 System of accuracy : JIS B 1702-1(ISO) class 8



New 仕様変更 省スペース・軽量化。
 Specification change Space-saving and weight saving.

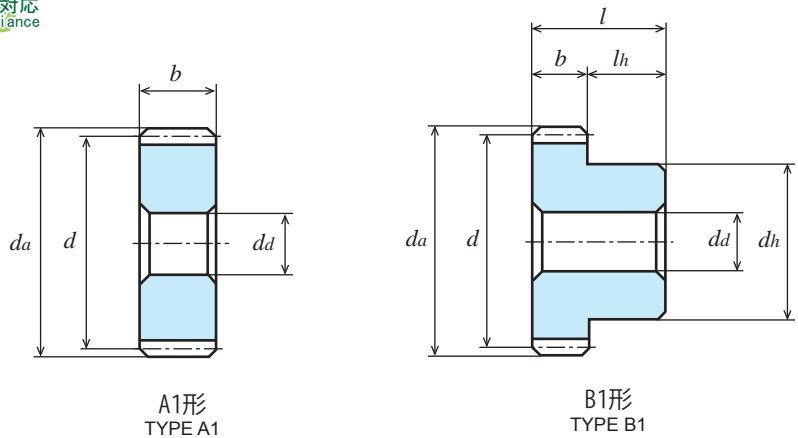

S45C 機械構造用炭素鋼 (JIS G 4051) Material : Carbon Steel (ISO C45)

単位 : mm
 Dimensions : mm

商品記号 Catalogue Number	歯数 Number of Teeth <i>z</i>	基準円直径 Reference Diameter <i>d</i>	歯先円直径 Tip Diameter <i>da</i>	形 Type	歯幅 Face Width <i>b</i>	穴径 Bore Diameter <i>da(H7)</i>	ハブ外径 Hub Diameter <i>dh</i>	ハブ長さ Hub Projection <i>lh</i>	全長 Overall Length <i>l</i>	キーみぞ Key Way <i>b₂ × t₂</i>	重量 Weight <i>W(g)</i>
S2.5S 18A - 1612	18	φ45	φ50	A1	16	φ12	-	-	16	-	185.6
S2.5S 18A - 1812	18	φ45	φ50	A1	18	φ12	-	-	18	-	208.7
S2.5S 18A - 2512	18	φ45	φ50	A1	25	φ12	-	-	25	-	289.9
S2.5S 18A - 2814	18	φ45	φ50	A1	28	φ14	-	-	28	-	315.7
S2.5S 18B - 1612N	18	φ45	φ50	B1	16	φ12	φ36	12	28	-	271.0
S2.5S 18B - 1814N	18	φ45	φ50	B1	18	φ14	φ36	12	30	-	284.5
S2.5S 18B - 2512N	18	φ45	φ50	B1	25	φ12(H8)	φ36	12	37	-	375.4
S2.5S 18B - 2814N	18	φ45	φ50	B1	28	φ14	φ36	12	40	-	397.4

許容伝達動力表 曲げ強さ (kW)

T (N · m)

Allowable transfer capability table (W) Bending Strength

歯数 <i>z</i>	歯幅 <i>b</i>	回転速度 (min ⁻¹) revolution/min							回転速度 (min ⁻¹) revolution/min
		10	100	200	400	800	1,200	1,500	100
18	16	0.066	0.66	1.32	2.64	4.67	6.23	7.48	63.02
18	18	0.074	0.74	1.48	2.97	5.25	7.01	8.41	70.66
18	25	0.103	1.03	2.07	4.14	7.30	9.74	11.69	98.36
18	28	0.116	1.16	2.32	4.63	8.18	10.91	13.09	110.77

The above numerical values are equivalent to JGMA formulas as reference only.

動力の換算式は P26 をご参照ください。Please refer to the conversion fomulas of power on page P26.

平歯車

SPUR GEARS

モジュール **2.5** 圧力角 20° (並歯) 歯数 20
 MODULE 20° PRESSURE ANGLE FULL DEPTH TOOTH Z 20

JIS B 1702-1 (ISO) 8級 (高周波焼入品: 9級)
 System of accuracy: JIS B 1702-1(ISO) class 8
 (Induction hardened products: class 9)



御注文には必ず“フルネームで商品記号”を明記してください。
 Please refer to the catalogue reference while ordering.

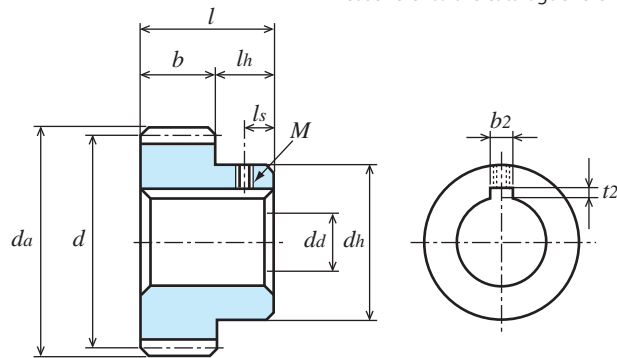

B1形
TYPE B1

S45C 機械構造用炭素鋼 (JIS G 4051) Material: Carbon Steel (ISO C45)

単位: mm
 Dimensions: mm

商品記号 Catalogue Number	歯数 Number of Teeth z	基準円直径 Reference Diameter d	歯先円直径 Outside Diameter da	形 Type	歯幅 Face Width b	穴径 Bore Diameter da(H7)	ハブ 外径 Hub Diameter dh	ハブ 長さ Hub Projection lh	全長 Overall Length l	キー みぞ Key Way b2 × t2	ねじ Set Screw		リム内径 Dimension of Rim di	ウエブ 厚さ Thickness of Web bw	重量 Weight W(g)
											M	ls			
S2.5S 20A - 1612F	20	φ50	φ55	A1	16	φ12	-	-	16	-	-	-	-	-	232.4
S2.5S 20A - 1812F	20	φ50	φ55	A1	18	φ12	-	-	18	-	-	-	-	-	261.5
S2.5S 20A = 1815	20	φ50	φ55	A1	18	φ15	-	-	18	5 × 2.3	-	-	-	-	250.8
S2.5S 20A = 1820	20	φ50	φ55	A1	18	φ20	-	-	18	6 × 2.8	-	-	-	-	230.7
S2.5S 20A - 2514F	20	φ50	φ55	A1	25	φ14	-	-	25	-	-	-	-	-	355.1
S2.5S 20A - 2814F	20	φ50	φ55	A1	28	φ14	-	-	28	-	-	-	-	-	397.7
S2.5S 20A = 2820	20	φ50	φ55	A1	28	φ20	-	-	28	6 × 2.8	-	-	-	-	358.8
S2.5S 20A = 2825	20	φ50	φ55	A1	28	φ25	-	-	28	8 × 3.3	-	-	-	-	317.9
S2.5S 20B - 1612	20	φ50	φ55	B1	16	φ12	φ42	12	28	-	-	-	-	-	352.5
S2.5S 20B - 1812	20	φ50	φ55	B1	18	φ12	φ40	12	30	-	-	-	-	-	369.4
S2.5S 20B # 1815	20	φ50	φ55	B1	18	φ15	φ40	12	30	5 × 2.3	M4	6	-	-	350.9
S2.5S 20B # 1818	20	φ50	φ55	B1	18	φ18	φ40	12	30	6 × 2.8	M5	6	-	-	331.1
S2.5S 20B # 1820	20	φ50	φ55	B1	18	φ20	φ40	12	30	6 × 2.8	M5	6	-	-	317.2
● S2.5S20BF - 2510	20	φ50	φ55	B1	25	φ10(H8)	φ42	20	45	-	-	-	-	-	569.3
● S2.5S20B - 2510H	20	φ50	φ55	B1	25	φ10(H※)	φ42	20	45	-	-	-	-	-	569.3
S2.5S 20B - 2514	20	φ50	φ55	B1	25	φ14	φ42	12	37	-	-	-	-	-	471.4
S2.5S 20B - 2814	20	φ50	φ55	B1	28	φ14	φ42	12	40	-	-	-	-	-	514.1
S2.5S 20B # 2820	20	φ50	φ55	B1	28	φ20	φ42	12	40	6 × 2.8	M5	6	-	-	457.4
S2.5S 20B # 2825	20	φ50	φ55	B1	28	φ25	φ42	12	40	8 × 3.3	M5	6	-	-	399.3

● の商品は新商品です。Products with ● marks are new item.

【=】(イコール)にはキー材が付いております。 [=]: Gear with key way / with key

【#】(シャープ)にはキー材とセットスクリューが付いております。 [#]: Gear with key way and threaded hole / with key and screw.

カタログ記号の末尾に【H】を付した商品は歯部高周波焼入済です。 Gear tooth surface completed with induction hardening, Hardness HRC47 to 53.

※ 歯部高周波焼入後の穴修正は行っていません。 Bore correcting after induction hardening is not completed.
 追加加工の際は、追加加工時の注意をご参照ください。 Please refer to Precaution for additional process when additional process.

許容伝達動力表 曲げ強さ (kW)

Allowable transfer capability table (W) Bending Strength

歯数 z	歯幅 b	焼入 H	回転速度 (min ⁻¹) revolution/min						
			10	100	200	400	800	1,200	1,500
20	16	-	0.077	0.78	1.55	3.09	5.34	7.13	8.66
20	18	-	0.087	0.87	1.75	3.47	6.01	8.03	9.74
20	25	-	0.122	1.220	2.450	4.860	8.400	11.230	13.620
20	25	○	0.130	1.297	2.593	5.153	9.025	12.163	14.791
20	28	-	0.136	1.36	2.72	5.40	9.34	12.48	15.15

The above references are JGMA standard.

動力の換算式は P26 をご参照ください。 Please refer to the conversion formulas of power on page P26.

許容伝達動力表 歯面強さ (kW)

Allowable transfer capability table (kW) Surface Durability

回転速度 (min ⁻¹) revolution/min							
10	100	200	400	800	1,200	1,500	
-	-	-	-	-	-	-	
-	-	-	-	-	-	-	
0.006	0.060	0.110	0.230	0.400	0.550	0.680	
0.025	0.274	0.564	1.156	2.087	2.863	3.516	
-	-	-	-	-	-	-	

目次
CONTENTS

インフォメーション
INFORMATION

ギヤボックス
GEAR BOXES

ノーバッキングギヤ
ANTI BACKLASH SPUR GEARS

歯研削歯車
GROUND SPUR GEARS

平歯車
SPUR GEARS

内歯車
INTERNAL GEARS

歯ラック
GROUND RACKS

ラック
RACKS

ハニカムギヤ
HEXIL GEAR AND SCREW GEARS

ワームとワームホイール
WORMS AND WORM WHEELS

かさ歯車
BEVEL GEARS

スプロケット
SPROCKETS

技術資料
REFERENCE DATA

平歯車 SPUR GEARS

モジュール **2.5** 圧力角 20° (並歯) 歯数 24
 MODULE 20° PRESSURE ANGLE FULL DEPTH TOOTH Z 24

JIS B 1702-1 (ISO) 8 級
 System of accuracy : JIS B 1702-1(ISO) class 8



New 仕様変更 省スペース・軽量化、締結加工不要。
 Specification change Space-saving and weight saving.
 Additional machining on tightening is not necessary.

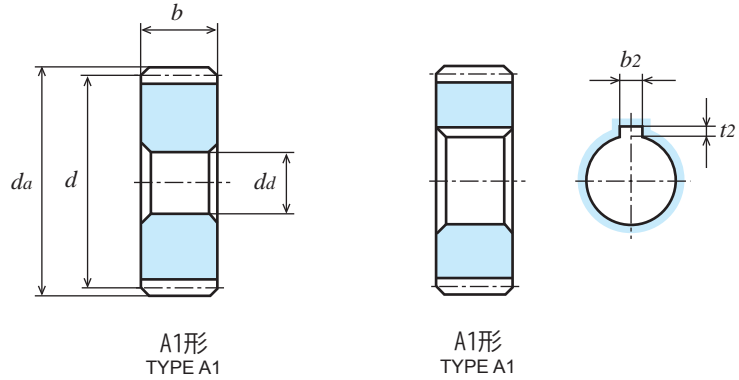

S45C 機械構造用炭素鋼 (JIS G 4051) Material : Carbon Steel (ISO C45)

単位 : mm
 Dimensions : mm

商品記号 Catalogue Number	歯数 Number of Teeth z	基準円直径 Reference Diameter d	歯先円直径 Outside Diameter da	形 Type	歯幅 Face Width b	穴径 Bore Diameter da(H7)	ハブ外径 Hub Diameter dh	ハブ長さ Hub Projection lh	全長 Overall Length l	キミぞ Key Way b ₂ × t ₂	ねじ Set Screw		リム内径 Dimension of Rim di	ウェブ厚さ Thickness of Web bw	重量 Weight W(g)
											M	ls			
S2.5S 24A - 1614F	24	φ60	φ65	A1	16	φ14	-	-	16	-	-	-	-	335.8	
S2.5S 24A - 1814F	24	φ60	φ65	A1	18	φ14	-	-	18	-	-	-	-	377.8	
S2.5S 24A = 1815	24	φ60	φ65	A1	18	φ15	-	-	18	5 × 2.3	-	-	-	372.9	
S2.5S 24A = 1820	24	φ60	φ65	A1	18	φ20	-	-	18	6 × 2.8	-	-	-	352.8	
S2.5S 24A - 2514F	24	φ60	φ65	A1	25	φ14	-	-	25	-	-	-	-	524.7	
S2.5S 24A - 2814F	24	φ60	φ65	A1	28	φ14	-	-	28	-	-	-	-	587.6	
S2.5S 24A = 2820	24	φ60	φ65	A1	28	φ20	-	-	28	6 × 2.8	-	-	-	548.7	
S2.5S 24A = 2825	24	φ60	φ65	A1	28	φ25	-	-	28	8 × 3.3	-	-	-	507.8	
S2.5S 24B - 1614	24	φ60	φ65	B1	16	φ14	φ50	12	28	-	-	-	-	506.6	
S2.5S 24B - 1814	24	φ60	φ65	B1	18	φ14	φ40	12	30	-	-	-	-	482.0	
S2.5S 24B # 1815	24	φ60	φ65	B1	18	φ15	φ40	12	30	5 × 2.3	M4	6	-	473.0	
S2.5S 24B # 1818	24	φ60	φ65	B1	18	φ18	φ40	12	30	6 × 2.8	M5	6	-	453.3	
S2.5S 24B # 1820	24	φ60	φ65	B1	18	φ20	φ40	12	30	6 × 2.8	M5	6	-	439.3	
S2.5S 24B - 2515	24	φ60	φ65	B1	25	φ15	φ50	12	37	-	-	-	-	689.0	
S2.5S 24B - 2815	24	φ60	φ65	B1	28	φ15	φ50	12	40	-	-	-	-	751.4	
S2.5S 24B # 2820	24	φ60	φ65	B1	28	φ20	φ50	12	40	6 × 2.8	M5	6	-	701.4	
S2.5S 24B # 2825	24	φ60	φ65	B1	28	φ25	φ50	12	40	8 × 3.3	M6	6	-	642.7	

【=】 (イコール) にはキー材が付いております。 [=] : Gear with key way / with key
 【#】 (シャープ) にはキー材とセットスクリューが付いております。 [#] : Gear with key way and threaded hole / with key and screw.

許容伝達動力表 曲げ強さ (kW)

T (N · m)

Allowable transfer capability table (W) Bending Strength

歯数 z	歯幅 b	回転速度 (min ⁻¹) revolution/min							回転速度 (min ⁻¹) revolution/min
		10	100	200	400	800	1,200	1,500	
24	16	0.101	1.01	2.03	3.90	6.60	9.08	10.97	100
24	18	0.114	1.14	2.28	4.39	7.43	10.22	12.34	96.45
24	25	0.158	1.58	3.17	6.10	10.32	14.19	17.13	108.86
24	28	0.177	1.77	3.55	6.83	11.56	15.89	19.19	150.88
									169.02

The above numerical values are equivalent to JGMA formulas as reference only.
 動力の換算式は P26 をご参照ください。 Please refer to the conversion fomulas of power on page P26.

平歯車

SPUR GEARS

モジュール **2.5** 圧力角 20° (並歯) 歯数 25
 MODULE 20° PRESSURE ANGLE FULL DEPTH TOOTH Z 25

JIS B 1702-1 (ISO) 8級 (高周波焼入品: 9級)
 System of accuracy: JIS B 1702-1(ISO) class 8
 (Induction hardened products: class 9)



御注文には必ず“フルネームで商品記号”を明記してください。
 Please refer to the catalogue reference while ordering.

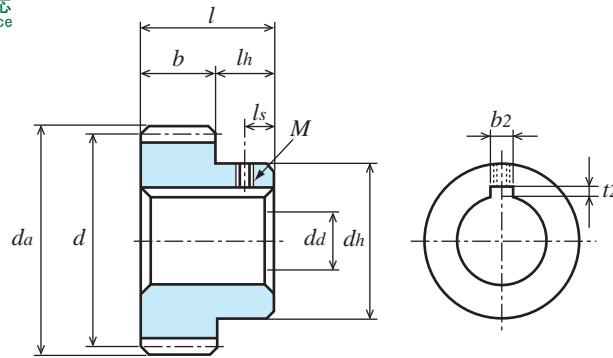

B1形
TYPE B1

S45C 機械構造用炭素鋼 (JIS G 4051) Material: Carbon Steel (ISO C45)

単位: mm
 Dimensions: mm

商品記号 Catalogue Number	歯数 Number of Teeth z	基準円直径 Reference Diameter d	歯先円直径 Outside Diameter da	形 Type	歯幅 Face Width b	穴径 Bore Diameter da(H7)	ハブ外径 Hub Diameter dh	ハブ長さ Hub Projection lh	全長 Overall Length l	キミぞ Key Way b2 × t2	ねじ Set Screw		リム内径 Dimension of Rim di	ウエブ厚さ Thickness of Web bw	重量 Weight W(g)
											M	ls			
S2.5S 25A - 1614F	25	φ62.5	φ67.5	A1	16	φ14	-	-	16	-	-	-	-	-	366.0
S2.5S 25A - 1814F	25	φ62.5	φ67.5	A1	18	φ14	-	-	18	-	-	-	-	-	411.8
S2.5S 25A = 1815	25	φ62.5	φ67.5	A1	18	φ15	-	-	18	5 × 2.3	-	-	-	-	406.9
S2.5S 25A = 1820	25	φ62.5	φ67.5	A1	18	φ20	-	-	18	6 × 2.8	-	-	-	-	386.7
S2.5S 25A - 2516F	25	φ62.5	φ67.5	A1	25	φ16	-	-	25	-	-	-	-	-	562.6
S2.5S 25A - 2816F	25	φ62.5	φ67.5	A1	28	φ16	-	-	28	-	-	-	-	-	630.1
S2.5S 25A = 2820	25	φ62.5	φ67.5	A1	28	φ20	-	-	28	6 × 2.8	-	-	-	-	601.6
S2.5S 25A = 2825	25	φ62.5	φ67.5	A1	28	φ25	-	-	28	8 × 3.3	-	-	-	-	560.6
S2.5S 25B - 1614	25	φ62.5	φ67.5	B1	16	φ14	φ52	12	28	-	-	-	-	-	551.9
S2.5S 25B - 1814	25	φ62.5	φ67.5	B1	18	φ14	φ40	12	30	-	-	-	-	-	516.0
S2.5S 25B # 1815	25	φ62.5	φ67.5	B1	18	φ15	φ40	12	30	5 × 2.3	M4	6	-	-	507.0
S2.5S 25B # 1818	25	φ62.5	φ67.5	B1	18	φ18	φ40	12	30	6 × 2.8	M5	6	-	-	487.3
S2.5S 25B # 1820	25	φ62.5	φ67.5	B1	18	φ20	φ40	12	30	6 × 2.8	M5	6	-	-	473.3
● S2.5S 25BF - 2510	25	φ62.5	φ67.5	B1	25	φ10(H8)	φ52	20	45	-	-	-	-	-	900.9
● S2.5S 25B - 2510H	25	φ62.5	φ67.5	B1	25	φ10(H※)	φ52	20	45	-	-	-	-	-	900.9
S2.5S 25B - 2515	25	φ62.5	φ67.5	B1	25	φ15	φ52	12	37	-	-	-	-	-	751.3
S2.5S 25B - 2815	25	φ62.5	φ67.5	B1	28	φ15	φ50	12	40	-	-	-	-	-	804.3
S2.5S 25B # 2820	25	φ62.5	φ67.5	B1	28	φ20	φ50	12	40	6 × 2.8	M5	6	-	-	754.3
S2.5S 25B # 2825	25	φ62.5	φ67.5	B1	28	φ25	φ50	12	40	8 × 3.3	M6	6	-	-	695.5

● の商品は新商品です。Products with ● marks are new item.

【=】(イコール)にはキー材が付いております。 [=]: Gear with key way / with key

【#】(シャープ)にはキー材とセットスクリューが付いております。 [#]: Gear with key way and threaded hole / with key and screw.

カタログ記号の末尾に【H】を付した商品は歯部高周波焼入済です。Gear tooth surface completed with induction hardening, Hardness HRC47 to 53.

※

歯部高周波焼入後の穴修正は行っていません。Bore correcting after induction hardening is not completed.

追加加工の際は、追加加工時の注意をご参照ください。Please refer to Precaution for additional process when additional process.

許容伝達動力表 曲げ強さ (kW)

Allowable transfer capability table (W) Bending Strength

歯数 z	歯幅 b	焼入 H	回転速度 (min ⁻¹) revolution/min						
			10	100	200	400	800	1,200	1,500
25	16	-	0.107	1.07	2.15	4.10	6.91	9.57	11.54
25	18	-	0.121	1.21	2.41	4.62	7.77	10.76	12.98
25	25	-	0.168	1.680	3.370	6.430	10.830	15.000	18.090
25	25	○	0.178	1.784	3.568	6.848	11.693	16.282	19.684
25	28	-	0.188	1.88	3.76	7.18	12.09	16.74	20.19

The above references are JGMA standard.

動力の換算式は P26 をご参照ください。Please refer to the conversion formulas of power on page P26.

許容伝達動力表 歯面強さ (kW)

Allowable transfer capability table (kW) Surface Durability

回転速度 (min ⁻¹) revolution/min						
10	100	200	400	800	1,200	1,500
-	-	-	-	-	-	-
-	-	-	-	-	-	-
0.009	0.090	0.180	0.350	0.610	0.870	1.080
0.039	0.437	0.901	1.782	3.136	4.446	5.428
-	-	-	-	-	-	-

目次
CONTENTS

インフォメーション
INFORMATION

ギヤボックス
GEAR BOXES

ノーバッキングギヤ
ANTI BACKLASH SPUR GEARS

歯研削歯車
GROUND SPUR GEARS

歯車
SPUR GEARS

内歯車
INTERNAL GEARS

歯車
GROUND RACKS

ラック
RACKS

ハブ・スクリューギヤ
HUBS AND SCREW GEARS

ウォーム・ウォームギヤ
WORMS AND WORM GEARS

かさ歯車
BEVEL GEARS

スプロケット
SPROCKETS

技術データ
REFERENCE DATA

平歯車

SPUR GEARS

モジュール **2.5** 圧力角 20° (並歯) 歯数 28
 MODULE 20° PRESSURE ANGLE FULL DEPTH TOOTH Z 28

JIS B 1702-1 (ISO) 8 級
 System of accuracy : JIS B 1702-1(ISO) class 8



New 仕様変更 省スペース・軽量化、締結加工不要。
 Specification change Space-saving and weight saving.
 Additional machining on tightening is not necessary.

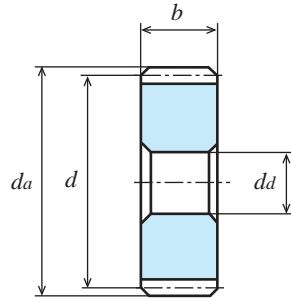

A1形
TYPE A1

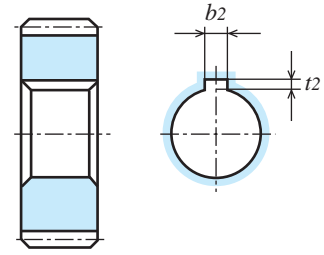

A1形
TYPE A1

S45C 機械構造用炭素鋼 (JIS G 4051)

Material : Carbon Steel (ISO C45)

単位 : mm
 Dimensions : mm

商品記号 Catalogue Number	歯数 Number of Teeth <i>z</i>	基準円直径 Reference Diameter <i>d</i>	歯先円直径 Outside Diameter <i>da</i>	形 Type	歯幅 Face Width <i>b</i>	穴径 Bore Diameter <i>da</i> (H7)	ハブ外径 Hub Diameter <i>dh</i>	ハブ長さ Hub Projection <i>lh</i>	全長 Overall Length <i>l</i>	キミぞ Key Way <i>b2 × t2</i>	ねじ Set Screw		リム内径 Dimension of Rim <i>di</i>	ウェブ厚さ Thickness of Web <i>bw</i>	重量 Weight <i>W</i> (kg)
											<i>M</i>	<i>ls</i>			
S2.5S 28A - 1614F	28	φ70	φ75	A1	16	φ14	-	-	16	-	-	-	-	-	0.46
S2.5S 28A - 1814F	28	φ70	φ75	A1	18	φ14	-	-	18	-	-	-	-	-	0.52
S2.5S 28A = 1815	28	φ70	φ75	A1	18	φ15	-	-	18	5 × 2.3	-	-	-	-	0.52
S2.5S 28A = 1820	28	φ70	φ75	A1	18	φ20	-	-	18	6 × 2.8	-	-	-	-	0.50
S2.5S 28A - 2516F	28	φ70	φ75	A1	25	φ16	-	-	25	-	-	-	-	-	0.72
S2.5S 28A - 2816F	28	φ70	φ75	A1	28	φ16	-	-	28	-	-	-	-	-	0.80
S2.5S 28A = 2820	28	φ70	φ75	A1	28	φ20	-	-	28	6 × 2.8	-	-	-	-	0.77
S2.5S 28A = 2825	28	φ70	φ75	A1	28	φ25	-	-	28	8 × 3.3	-	-	-	-	0.73
S2.5S 28B - 1614	28	φ70	φ75	B1	16	φ14	φ60	12	28	-	-	-	-	-	0.72
S2.5S 28B - 1814	28	φ70	φ75	B1	18	φ14	φ40	12	30	-	-	-	-	-	0.63
S2.5S 28B # 1815	28	φ70	φ75	B1	18	φ15	φ40	12	30	5 × 2.3	M4	6	-	-	0.62
S2.5S 28B # 1818	28	φ70	φ75	B1	18	φ18	φ40	12	30	6 × 2.8	M5	6	-	-	0.60
S2.5S 28B # 1820	28	φ70	φ75	B1	18	φ20	φ40	12	30	6 × 2.8	M5	6	-	-	0.58
S2.5S 28B - 2516	28	φ70	φ75	B1	25	φ16	φ50	12	37	-	-	-	-	-	0.96
S2.5S 28B - 2816	28	φ70	φ75	B1	28	φ16	φ50	12	40	-	-	-	-	-	0.97
S2.5S 28B # 2820	28	φ70	φ75	B1	28	φ20	φ50	12	40	6 × 2.8	M5	6	-	-	0.93
S2.5S 28B # 2825	28	φ70	φ75	B1	28	φ25	φ50	12	40	8 × 3.3	M6	6	-	-	0.87

【=】(イコール)にはキー材が付いております。【=】: Gear with key way / with key
 【#】(シャープ)にはキー材とセットスクリューが付いております。【#】: Gear with key way and threaded hole / with key and screw.

許容伝達動力表 曲げ強さ (kW)

T (N · m)

Allowable transfer capability table (W) Bending Strength

歯数 <i>z</i>	歯幅 <i>b</i>	回転速度 (min ⁻¹) revolution/min							回転速度 (min ⁻¹) revolution/min
		10	100	200	400	800	1,200	1,500	
28	16	0.13	1.26	2.51	4.70	7.79	11.01	13.30	100
28	18	0.14	1.41	2.83	5.28	8.77	12.38	14.97	120.32
28	25	0.20	1.96	3.93	7.34	12.18	17.20	20.79	134.65
28	28	0.22	2.20	4.40	8.22	13.64	19.26	23.28	187.17
									210.09

The above numerical values are equivalent to JGMA formulas as reference only.
 動力の換算式は P26 をご参照ください。Please refer to the conversion fomulas of power on page P26.

平歯車

SPUR GEARS

モジュール **2.5** 圧力角 20° (並歯) 歯数 30
 MODULE 20° PRESSURE ANGLE FULL DEPTH TOOTH Z30

JIS B 1702-1 (ISO) 8級 (高周波焼入品: 9級)
 System of accuracy: JIS B 1702-1(ISO) class 8
 (Induction hardened products: class 9)



御注文には必ず“フルネームで商品記号”を明記してください。
 Please refer to the catalogue reference while ordering.

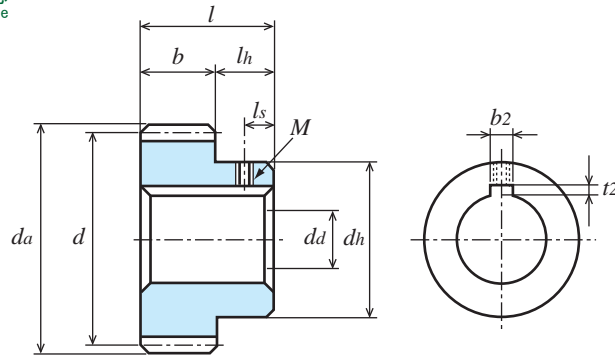

B1形
TYPE B1

S45C 機械構造用炭素鋼 (JIS G 4051) Material: Carbon Steel (ISO C45)

単位: mm
 Dimensions: mm

商品記号 Catalogue Number	歯数 Number of Teeth z	基準円直径 Reference Diameter d	歯先円直径 Outside Diameter da	形 Type	歯幅 Face Width b	穴径 Bore Diameter da(H7)	ハブ外径 Hub Diameter dh	ハブ長さ Hub Projection lh	全長 Overall Length l	キミぞ Key Way b2 × t2	ねじ Set Screw		リム内径 Dimension of Rim di	ウエブ厚さ Thickness of Web bw	重量 Weight W(kg)
											M	ls			
S2.5S 30A - 1616F	30	φ75	φ80	A1	16	φ16	-	-	16	-	-	-	-	0.53	
S2.5S 30A - 1816F	30	φ75	φ80	A1	18	φ16	-	-	18	-	-	-	-	0.60	
S2.5S 30A = 1820	30	φ75	φ80	A1	18	φ20	-	-	18	6 × 2.8	-	-	-	0.58	
S2.5S 30A - 2518F	30	φ75	φ80	A1	25	φ18	-	-	25	-	-	-	-	0.82	
S2.5S 30A = 2520	30	φ75	φ80	A1	25	φ20	-	-	25	6 × 2.8	-	-	-	0.80	
S2.5S 30A = 2525	30	φ75	φ80	A1	25	φ25	-	-	25	8 × 3.3	-	-	-	0.77	
S2.5S 30B - 1614	30	φ75	φ80	B1	16	φ14	φ65	12	28	-	-	-	-	0.83	
S2.5S 30B - 1814	30	φ75	φ80	B1	18	φ14	φ40	12	30	-	-	-	-	0.71	
S2.5S 30B # 1815	30	φ75	φ80	B1	18	φ15	φ40	12	30	5 × 2.3	M4	6	-	0.70	
S2.5S 30B # 1818	30	φ75	φ80	B1	18	φ18	φ40	12	30	6 × 2.8	M5	6	-	0.68	
S2.5S 30B # 1820	30	φ75	φ80	B1	18	φ20	φ40	12	30	6 × 2.8	M5	6	-	0.66	
● S2.5S 30BF - 2512	30	φ75	φ80	B1	25	φ12(H8)	φ65	20	45	-	-	-	-	1.34	
● S2.5S 30B - 2512H	30	φ75	φ80	B1	25	φ12(H※)	φ65	20	45	-	-	-	-	1.34	
S2.5S 30B - 2516	30	φ75	φ80	B1	25	φ16	φ65	12	37	-	-	-	-	1.12	
S2.5S 30B - 2816	30	φ75	φ80	B1	28	φ16	φ50	12	40	-	-	-	-	1.09	
S2.5S 30B # 2820	30	φ75	φ80	B1	28	φ20	φ50	12	40	6 × 2.8	M5	6	-	1.05	
S2.5S 30B # 2825	30	φ75	φ80	B1	28	φ25	φ50	12	40	8 × 3.3	M6	6	-	0.99	

● の商品は新商品です。Products with ● marks are new item.

【=】(イコール)にはキー材が付いております。【=】: Gear with key way / with key

【#】(シャープ)にはキー材とセットスクリューが付いております。【#】: Gear with key way and threaded hole / with key and screw.

カタログ記号の末尾に【H】を付した商品は歯部高周波焼入済です。Gear tooth surface completed with induction hardening, Hardness HRC47 to 53.

※ 歯部高周波焼入後の穴修正は行っていません。Bore correcting after induction hardening is not completed.

追加加工の際は、追加加工時の注意をご参照ください。Please refer to Precaution for additional process when additional process.

許容伝達動力表 曲げ強さ (kW)

Allowable transfer capability table (W) Bending Strength

歯数 z	歯幅 b	焼入 H	回転速度 (min ⁻¹) revolution/min						
			10	100	200	400	800	1,200	1,500
30	16	-	0.14	1.38	2.76	5.08	8.44	11.95	14.47
30	18	-	0.16	1.55	3.10	5.72	9.50	13.44	16.28
30	25	-	0.220	2.160	4.320	7.950	13.210	18.690	22.640
30	25	○	0.229	2.288	4.575	8.490	14.307	20.326	25.163
30	28	-	0.24	2.41	4.82	8.89	14.77	20.91	25.33

The above references are JGMA standard.

動力の換算式はP26をご参照ください。Please refer to the conversion formulas of power on page P26.

許容伝達動力表 歯面強さ (kW)

Allowable transfer capability table (kW) Surface Durability

回転速度 (min ⁻¹) revolution/min						
10	100	200	400	800	1,200	1,500
-	-	-	-	-	-	-
-	-	-	-	-	-	-
0.013	0.130	0.270	0.500	0.860	1.270	1.590
0.058	0.640	1.320	2.524	4.385	6.342	7.928
-	-	-	-	-	-	-

平歯車 SPUR GEARS

モジュール **2.5** 圧力角 20° (並歯) 歯数 32
 MODULE 20° PRESSURE ANGLE FULL DEPTH TOOTH Z32

JIS B 1702-1 (ISO) 8級
 System of accuracy : JIS B 1702-1(ISO) class 8



New 仕様変更 省スペース・軽量化、締結加工不要。
 Specification change Space-saving and weight saving.
 Additional machining on tightening is not necessary.

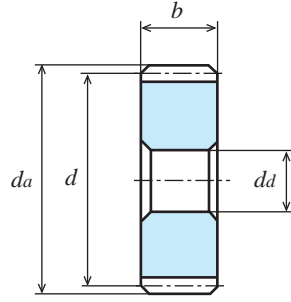

A1形
TYPE A1

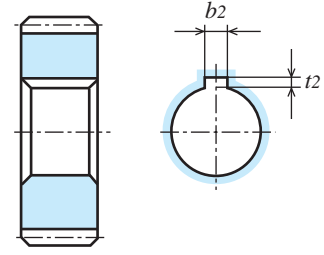

A1形
TYPE A1

S45C 機械構造用炭素鋼 (JIS G 4051) Material : Carbon Steel (ISO C45)

単位 : mm
 Dimensions : mm

商品記号 Catalogue Number	歯数 Number of Teeth <i>z</i>	基準円直径 Reference Diameter <i>d</i>	歯先円直径 Outside Diameter <i>da</i>	形 Type	歯幅 Face Width <i>b</i>	穴径 Bore Diameter <i>da</i> (H7)	ハブ外径 Hub Diameter <i>dh</i>	ハブ長さ Hub Projection <i>lh</i>	全長 Overall Length <i>l</i>	キーマイ Key Way <i>b2 × t2</i>	ねじ Set Screw		リム内径 Dimension of Rim <i>di</i>	ウェブ厚さ Thickness of Web <i>bw</i>	重量 Weight <i>W</i> (kg)
											<i>M</i>	<i>ls</i>			
S2.5S 32A - 1616F	32	φ80	φ85	A1	16	φ16	-	-	16	-	-	-	-	-	0.61
S2.5S 32A = 1620	32	φ80	φ85	A1	16	φ20	-	-	16	6 × 2.8	-	-	-	-	0.59
S2.5S 32A = 1625	32	φ80	φ85	A1	16	φ25	-	-	16	8 × 3.3	-	-	-	-	0.57
S2.5S 32A - 2518F	32	φ80	φ85	A1	25	φ18	-	-	25	-	-	-	-	-	0.94
S2.5S 32A = 2520	32	φ80	φ85	A1	25	φ20	-	-	25	6 × 2.8	-	-	-	-	0.92
S2.5S 32A = 2525	32	φ80	φ85	A1	25	φ25	-	-	25	8 × 3.3	-	-	-	-	0.88
S2.5S 32A = 2530	32	φ80	φ85	A1	25	φ30	-	-	25	8 × 3.3	-	-	-	-	0.84
S2.5S 32B - 1616	32	φ80	φ85	B1	16	φ16	φ50	12	28	-	-	-	-	-	0.77
S2.5S 32B # 1620	32	φ80	φ85	B1	16	φ20	φ50	12	28	6 × 2.8	M5	6	-	-	0.74
S2.5S 32B # 1625	32	φ80	φ85	B1	16	φ25	φ50	12	28	8 × 3.3	M6	6	-	-	0.70
S2.5S 32B - 2516	32	φ80	φ85	B1	25	φ16	φ60	12	37	-	-	-	-	-	1.20
S2.5S 32B # 2520	32	φ80	φ85	B1	25	φ20	φ60	12	37	6 × 2.8	M5	6	-	-	1.16
S2.5S 32B # 2525	32	φ80	φ85	B1	25	φ25	φ60	12	37	8 × 3.3	M6	6	-	-	1.10
S2.5S 32B # 2530	32	φ80	φ85	B1	25	φ30	φ60	12	37	8 × 3.3	M6	6	-	-	1.04

【=】 (イコール) にはキーマ材が付いております。【=】: Gear with key way / with key

【#】 (シャープ) にはキーマ材とセットスクリューが付いております。【#】: Gear with key way and threaded hole / with key and screw.

許容伝達動力表 曲げ強さ (kW)

Allowable transfer capability table (W) Bending Strength

歯数 <i>z</i>	歯幅 <i>b</i>	回転速度 (min ⁻¹) revolution/min							回転速度 (min ⁻¹) revolution/min
		10	100	200	400	800	1,200	1,500	
32	16	0.15	1.50	3.01	5.46	9.13	12.89	15.64	100
32	25	0.24	2.35	4.70	8.54	14.27	20.14	24.44	143.24
									224.41

The above numerical values are equivalent to JGMA formulas as reference only.

動力の換算式は P26 をご参照ください。Please refer to the conversion fomulas of power on page P26.

平歯車

SPUR GEARS

モジュール **2.5** 圧力角 20° (並歯) 歯数 36
 MODULE 20° PRESSURE ANGLE FULL DEPTH TOOTH Z36

JIS B 1702-1 (ISO) 8級
 System of accuracy: JIS B 1702-1(ISO) class 8



御注文には必ず“フルネームで商品記号”を明記してください。
 Please refer to the catalogue reference while ordering.

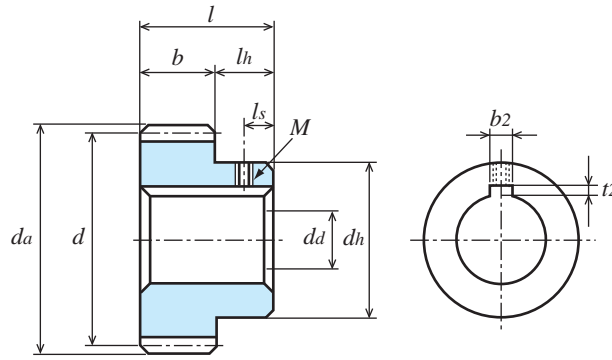

B1形
TYPE B1

S45C 機械構造用炭素鋼 (JIS G 4051) Material: Carbon Steel (ISO C45)

単位: mm
 Dimensions: mm

商品記号 Catalogue Number	歯数 Number of Teeth z	基準円直径 Reference Diameter d	歯先円直径 Outside Diameter da	形 Type	歯幅 Face Width b	穴径 Bore Diameter da(H7)	ハブ外径 Hub Diameter dh	ハブ長さ Hub Projection lh	全長 Overall Length l	キーマゾ Key Way b2 × t2	ねじ Set Screw		リム内径 Dimension of Rim di	ウェブ厚さ Thickness of Web bw	重量 Weight W(kg)
											M	ls			
S2.5S 36A - 1616F	36	φ90	φ95	A1	16	φ16	-	-	16	-	-	-	-	0.77	
S2.5S 36A = 1620	36	φ90	φ95	A1	16	φ20	-	-	16	6 × 2.8	-	-	-	0.76	
S2.5S 36A = 1625	36	φ90	φ95	A1	16	φ25	-	-	16	8 × 3.3	-	-	-	0.73	
S2.5S 36A - 2518F	36	φ90	φ95	A1	25	φ18	-	-	25	-	-	-	-	1.20	
S2.5S 36A = 2525	36	φ90	φ95	A1	25	φ25	-	-	25	8 × 3.3	-	-	-	1.15	
S2.5S 36A = 2530	36	φ90	φ95	A1	25	φ30	-	-	25	8 × 3.3	-	-	-	1.11	
S2.5S 36B - 1616	36	φ90	φ95	B1	16	φ16	φ50	12	28	-	-	-	-	0.94	
S2.5S 36B # 1620	36	φ90	φ95	B1	16	φ20	φ50	12	28	6 × 2.8	M5	6	-	0.91	
S2.5S 36B # 1625	36	φ90	φ95	B1	16	φ25	φ50	12	28	8 × 3.3	M6	6	-	0.87	
S2.5S 36B - 2518	36	φ90	φ95	B1	25	φ18	φ60	12	37	-	-	-	-	1.44	
S2.5S 36B # 2525	36	φ90	φ95	B1	25	φ25	φ60	12	37	8 × 3.3	M6	6	-	1.36	
S2.5S 36B # 2530	36	φ90	φ95	B1	25	φ30	φ60	12	37	8 × 3.3	M6	6	-	1.30	

【=】(イコール)にはキー材が付いております。【#】: Gear with key way / with key
 【#】(シャープ)にはキー材とセットスクリーンが付いております。【#】: Gear with key way and threaded hole / with key and screw.

許容伝達動力表 曲げ強さ (kW)

Allowable transfer capability table (W) Bending Strength

歯数 z	歯幅 b	回転速度 (min ⁻¹) revolution/min							回転速度 (min ⁻¹) revolution/min
		10	100	200	400	800	1,200	1,500	
36	16	0.18	1.76	3.51	6.20	10.50	14.83	17.94	100
36	25	0.27	2.75	5.49	9.69	16.41	23.17	28.03	168.07
									262.61

KG規格は“並幅”(軽荷重用)と“広幅”(重荷重用)があります。ご用途に応じてお選び下さい。
 KG STOCK GEARS has Wide-face width for Heavy load, and Standard-face width for Light load.

You are able to multiple choices for your suitable design from our wide range.
 The above numerical values are equivalent to JGMA formulas as reference only.
 動力の換算式はP26をご参照ください。Please refer to the conversion fomulas of power on page P26.

目次 CONTENTS

インフォメーション INFORMATION

ギヤボックス GEAR BOXES

ノーバックラッシュギヤ ANTI BACKLASH SPUR GEARS

歯研平歯車 GROUND SPUR GEARS

平歯車 SPUR GEARS

内歯車 INTERNAL GEARS

歯研ラック GROUND RACKS

ラック RACKS

へリカル・スクリューギヤ HELICAL GEARS AND SCREW GEARS

ウォーム・ウォームギヤ WORMS AND WORM GEAR

かさ歯車 BEVEL GEARS

スプロケット SPROCKETS

技術資料 REFERENCE DATA

平歯車 SPUR GEARS

モジュール **2.5** 圧力角 20° (並歯) 歯数 40 45
20° PRESSURE ANGLE FULL DEPTH TOOTH Z 40 to Z 45

JIS B 1702-1 (ISO) 8級 (高周波焼入品: 9級)
System of accuracy: JIS B 1702-1(ISO) class 8
(Induction hardened products: class 9)



New 仕様変更 省スペース・軽量化、締結加工不要。
Specification change Space-saving and weight saving.
Additional machining on tightening is not necessary.

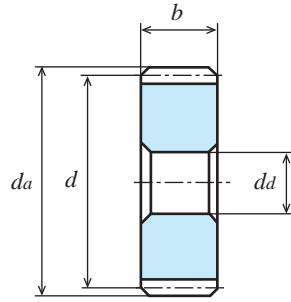

A1形
TYPE A1

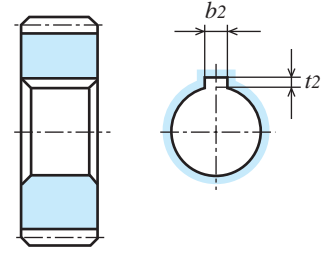

A1形
TYPE A1

S45C 機械構造用炭素鋼 (JIS G 4051) Material: Carbon Steel (ISO C45)

単位: mm
Dimensions: mm

商品記号 Catalogue Number	歯数 Number of Teeth z	基準円直径 Reference Diameter d	歯先円直径 Outside Diameter da	形 Type	歯幅 Face Width b	穴径 Bore Diameter da(H7)	ハブ外径 Hub Diameter dh	ハブ長さ Hub Projection lh	全長 Overall Length l	キミぞ Key Way b2 × t2	ねじ Set Screw		リム内径 Dimension of Rim di	ウェブ厚さ Thickness of Web bw	重量 Weight W(kg)
											M	ls			
S2.5S 40A - 1616F	40	φ100	φ105	A1	16	φ16	-	-	16	-	-	-	-	0.96	
S2.5S 40A = 1620	40	φ100	φ105	A1	16	φ20	-	-	16	6 × 2.8	-	-	-	0.94	
S2.5S 40A = 1625	40	φ100	φ105	A1	16	φ25	-	-	16	8 × 3.3	-	-	-	0.92	
S2.5S 40A - 2518F	40	φ100	φ105	A1	25	φ18	-	-	25	-	-	-	-	1.49	
S2.5S 40A = 2525	40	φ100	φ105	A1	25	φ25	-	-	25	8 × 3.3	-	-	-	1.44	
S2.5S 40A = 2530	40	φ100	φ105	A1	25	φ30	-	-	25	8 × 3.3	-	-	-	1.40	
S2.5S 40B - 1616	40	φ100	φ105	B1	16	φ16	φ50	12	28	-	-	-	-	1.13	
S2.5S 40B # 1620	40	φ100	φ105	B1	16	φ20	φ50	12	28	6 × 2.8	M5	6	-	1.10	
S2.5S 40B # 1625	40	φ100	φ105	B1	16	φ25	φ50	12	28	8 × 3.3	M6	6	-	1.06	
S2.5S 40BF - 2512	40	φ100	φ105	B1	25	φ12(H8)	φ70	20	45	-	-	-	-	2.1	
S2.5S 40B - 2512H	40	φ100	φ105	B1	25	φ12(H※)	φ70	20	45	-	-	-	-	2.1	
S2.5S 40B - 2518	40	φ100	φ105	B1	25	φ18	φ60	12	37	-	-	-	-	1.73	
S2.5S 40B # 2525	40	φ100	φ105	B1	25	φ25	φ60	12	37	8 × 3.3	M6	6	-	1.66	
S2.5S 40B # 2530	40	φ100	φ105	B1	25	φ30	φ60	12	37	8 × 3.3	M6	6	-	1.59	
S2.5S 45B - 1616	45	φ112.5	φ117.5	B1	16	φ16	φ60	12	28	-	-	-	-	1.47	
S2.5S 45B - 2518	45	φ112.5	φ117.5	B1	25	φ18	φ60	12	37	-	-	-	-	2.14	

●の商品は新商品です。Products with ● marks are new item.

【=】(イコール)にはキー材が付いております。 [=]: Gear with key way / with key

【#】(シャープ)にはキー材とセットスクリューが付いております。 [#]: Gear with key way and threaded hole / with key and screw.

カタログ記号の末尾に【H】を付した商品は歯部高周波焼入済です。 Gear tooth surface completed with induction hardening, Hardness HRC47 to 53.

※ 歯部高周波焼入後の穴修正は行っていません。 Bore correcting after induction hardening is not completed.

追加加工の際は、追加加工時の注意をご参照ください。 Please refer to Precaution for additional process when additional process.

許容伝達動力表 曲げ強さ (kW)

Allowable transfer capability table (W) Bending Strength

歯数 z	歯幅 b	焼入 H	回転速度 (min ⁻¹) revolution/min						
			10	100	200	400	800	1,200	1,500
40	16	-	0.20	2.01	4.00	6.92	11.85	16.74	20.19
40	25	-	0.310	3.140	6.230	10.780	18.470	26.100	31.480
40	25	○	0.333	3.327	6.612	11.580	20.061	29.278	36.598
45	16	-	0.23	2.33	4.55	7.76	13.48	19.07	23.35
45	25	-	0.36	3.65	7.11	12.13	21.06	29.80	36.48

The above references are JGMA standard.

動力の換算式は P26 をご参照ください。 Please refer to the conversion formulas of power on page P26.

許容伝達動力表 歯面強さ (kW)

Allowable transfer capability table (kW) Surface Durability

回転速度 (min ⁻¹) revolution/min						
10	100	200	400	800	1,200	1,500
-	-	-	-	-	-	-
0.024	0.240	0.480	0.860	1.550	2.320	2.900
0.106	1.169	2.396	4.326	7.725	11.476	14.486
-	-	-	-	-	-	-
-	-	-	-	-	-	-

平歯車

SPUR GEARS

モジュール **2.5** 圧力角 20° (並歯) 歯数 48
 MODULE 20° PRESSURE ANGLE FULL DEPTH TOOTH Z 48

JIS B 1702-1 (ISO) 8 級
 System of accuracy : JIS B 1702-1(ISO) class 8



御注文には必ず“フルネームで商品記号”を明記してください。
 Please refer to the catalogue reference while ordering.

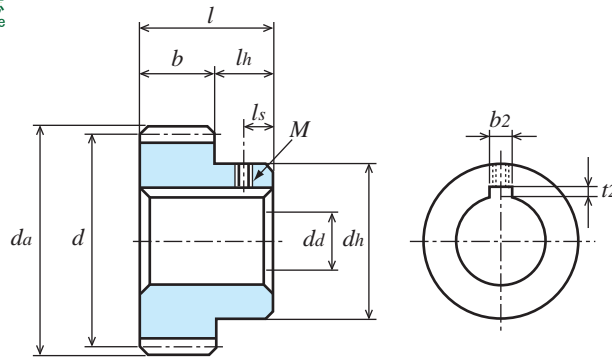

B1形
TYPE B1

S45C 機械構造用炭素鋼 (JIS G 4051)

Material : Carbon Steel (ISO C45)

単位 : mm
Dimensions : mm

商品記号 Catalogue Number	歯数 Number of Teeth z	基準円直径 Reference Diameter d	歯先円直径 Outside Diameter da	形 Type	歯幅 Face Width b	穴径 Bore Diameter da(H7)	ハブ外径 Hub Diameter dh	ハブ長さ Hub Projection lh	全長 Overall Length l	キーマイぞ Key Way b2 × t2	ねじ Set Screw		リム内径 Dimension of Rim di	ウエブ厚さ Thickness of Web bw	重量 Weight W(kg)
											M	ls			
S2.5S 48A - 1616F	48	φ120	φ125	A1	16	φ16	-	-	16	-	-	-	-	1.40	
S2.5S 48A = 1620	48	φ120	φ125	A1	16	φ20	-	-	16	6 × 2.8	-	-	-	1.38	
S2.5S 48A = 1625	48	φ120	φ125	A1	16	φ25	-	-	16	8 × 3.3	-	-	-	1.40	
S2.5S 48A - 2518F	48	φ120	φ125	A1	25	φ18	-	-	25	-	-	-	-	2.17	
S2.5S 48A = 2525	48	φ120	φ125	A1	25	φ25	-	-	25	8 × 3.3	-	-	-	2.12	
S2.5S 48A = 2530	48	φ120	φ125	A1	25	φ30	-	-	25	8 × 3.3	-	-	-	2.10	
S2.5S 48B - 1616	48	φ120	φ125	B1	16	φ16	φ50	12	28	-	-	-	-	1.56	
S2.5S 48B # 1620	48	φ120	φ125	B1	16	φ20	φ50	12	28	6 × 2.8	M5	6	-	1.53	
S2.5S 48B # 1625	48	φ120	φ125	B1	16	φ25	φ50	12	28	8 × 3.3	M6	6	-	1.49	
S2.5S 48B - 2518	48	φ120	φ125	B1	25	φ18	φ60	12	37	-	-	-	-	2.41	
S2.5S 48B # 2525	48	φ120	φ125	B1	25	φ25	φ60	12	37	8 × 3.3	M6	6	-	2.33	
S2.5S 48B # 2530	48	φ120	φ125	B1	25	φ30	φ60	12	37	8 × 3.3	M6	6	-	2.27	

【=】(イコール)にはキー材が付いております。【#】: Gear with key way / with key
 【#】(シャープ)にはキー材とセットスクリューが付いております。【#】: Gear with key way and threaded hole / with key and screw.

許容伝達動力表 曲げ強さ (kW)

Allowable transfer capability table (W) Bending Strength

歯数 z	歯幅 b	回転速度 (min ⁻¹) revolution/min							回転速度 (min ⁻¹) revolution/min
		10	100	200	400	800	1,200	1,500	
48	16	0.25	2.53	4.87	8.25	14.45	20.45	25.30	100
48	25	0.40	3.95	7.61	12.89	22.58	31.95	39.53	100

KG 規格は“並幅”(軽荷重用)と“広幅”(重荷重用)があります。ご用途に応じてお選び下さい。

KG STOCK GEARS has Wide-face width for Heavy load, and Standard-face width for Light load.

You are able to multiple choices for your suitable design from our wide range.

The above numerical values are equivalent to JGMA formulas as reference only.

動力の換算式は P26 をご参照ください。Please refer to the conversion fomulas of power on page P26.

平歯車 SPUR GEARS

モジュール **2.5** 圧力角 20° (並歯) 歯数 50
 MODULE 20° PRESSURE ANGLE FULL DEPTH TOOTH Z 50

JIS B 1702-1 (ISO) 8級 (高周波焼入品: 9級)
 System of accuracy: JIS B 1702-1(ISO) class 8
 (Induction hardened products: class 9)



New 仕様変更 省スペース・軽量化、締結加工不要。
 Specification change Space-saving and weight saving.
 Additional machining on tightening is not necessary.

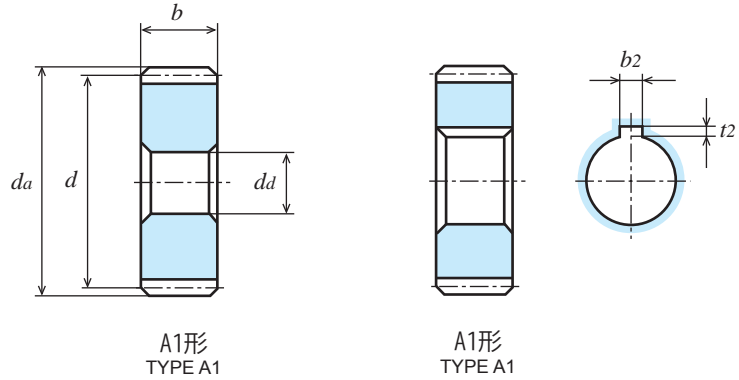

S45C 機械構造用炭素鋼 (JIS G 4051) Material: Carbon Steel (ISO C45)

単位: mm
 Dimensions: mm

商品記号 Catalogue Number	歯数 Number of Teeth z	基準円直径 Reference Diameter d	歯先円直径 Outside Diameter da	形 Type	歯幅 Face Width b	穴径 Bore Diameter da(H7)	ハブ外径 Hub Diameter dh	ハブ長さ Hub Projection lh	全長 Overall Length l	キミぞ Key Way b2 × t2	ねじ Set Screw		リム内径 Dimension of Rim di	ウェブ厚さ Thickness of Web bw	重量 Weight W(kg)
											M	ls			
S2.5S 50A - 1616F	50	φ125	φ130	A1	16	φ16	-	-	16	-	-	-	-	1.52	
S2.5S 50A = 1620	50	φ125	φ130	A1	16	φ20	-	-	16	6 × 2.8	-	-	-	1.50	
S2.5S 50A = 1625	50	φ125	φ130	A1	16	φ25	-	-	16	8 × 3.3	-	-	-	1.50	
S2.5S 50A - 2518F	50	φ125	φ130	A1	25	φ18	-	-	25	-	-	-	-	2.36	
S2.5S 50A = 2525	50	φ125	φ130	A1	25	φ25	-	-	25	8 × 3.3	-	-	-	2.31	
S2.5S 50A = 2530	50	φ125	φ130	A1	25	φ30	-	-	25	8 × 3.3	-	-	-	2.26	
S2.5S 50B - 1616	50	φ125	φ130	B1	16	φ16	φ50	12	28	-	-	-	-	1.68	
S2.5S 50B # 1620	50	φ125	φ130	B1	16	φ20	φ50	12	28	6 × 2.8	M5	6	-	1.65	
S2.5S 50B # 1625	50	φ125	φ130	B1	16	φ25	φ50	12	28	8 × 3.3	M6	6	-	1.61	
S2.5S 50BF - 2515	50	φ125	φ130	B1	25	φ15(H8)	φ90	20	45	-	-	-	-	3.33	
S2.5S 50B - 2515H	50	φ125	φ130	B1	25	φ15(H※)	φ90	20	45	-	-	-	-	3.33	
S2.5S 50B - 2518	50	φ125	φ130	B1	25	φ18	φ60	12	37	-	-	-	-	2.60	
S2.5S 50B # 2525	50	φ125	φ130	B1	25	φ25	φ60	12	37	8 × 3.3	M6	6	-	2.52	
S2.5S 50B # 2530	50	φ125	φ130	B1	25	φ30	φ60	12	37	8 × 3.3	M6	6	-	2.46	

●の商品は新商品です。Products with ● marks are new item.

【=】(イコール)にはキー材が付いております。 [=]: Gear with key way / with key

【#】(シャープ)にはキー材とセットスクリューが付いております。 [#]: Gear with key way and threaded hole / with key and screw.

カタログ記号の末尾に【H】を付した商品は歯部高周波焼入済です。 Gear tooth surface completed with induction hardening, Hardness HRC47 to 53.

※ 歯部高周波焼入後の穴修正は行っていません。 Bore correcting after induction hardening is not completed.

追加加工の際は、追加加工時の注意をご参照ください。 Please refer to Precaution for additional process when additional process.

許容伝達動力表 曲げ強さ (kW)

Allowable transfer capability table (W) Bending Strength

歯数 z	歯幅 b	焼入 H	回転速度 (min ⁻¹) revolution/min						
			10	100	200	400	800	1,200	1,500
50	16	-	0.27	2.66	5.09	8.56	15.12	21.36	26.61
50	25	-	0.410	4.140	7.910	13.330	23.530	33.230	41.400
50	25	○	0.439	4.389	8.423	14.383	25.750	38.625	48.281

The above references are JGMA standard.

動力の換算式はP26をご参照ください。 Please refer to the conversion formulas of power on page P26.

許容伝達動力表 歯面強さ (kW)

Allowable transfer capability table (kW) Surface Durability

回転速度 (min ⁻¹) revolution/min						
10	100	200	400	800	1,200	1,500
-	-	-	-	-	-	-
0.038	0.390	0.750	1.310	2.470	3.710	4.770
0.169	1.867	3.693	6.500	11.995	18.316	23.120

平歯車

SPUR GEARS

モジュール
MODULE

2.5

圧力角 20° (並歯) 歯数 56 60
20° PRESSURE ANGLE FULL DEPTH TOOTH Z 56 to Z 60

JIS B 1702-1 (ISO) 8級 (高周波焼入品: 9級)
System of accuracy: JIS B 1702-1(ISO) class 8
(Induction hardened products: class 9)



御注文には必ず“フルネームで商品記号”を明記してください。
Please refer to the catalogue reference while ordering.

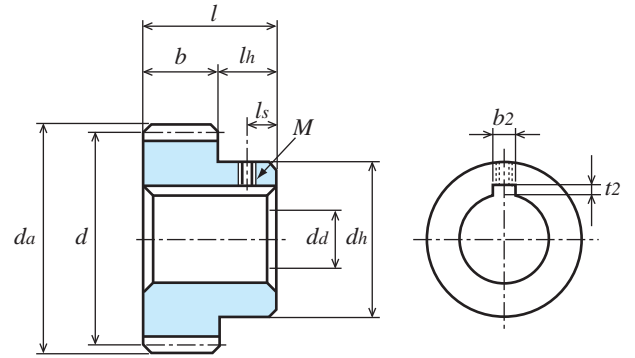

B1形
TYPE B1

S45C 機械構造用炭素鋼 (JIS G 4051) Material: Carbon Steel (ISO C45)

単位: mm
Dimensions: mm

商品記号 Catalogue Number	歯数 Number of Teeth z	基準円直径 Reference Diameter d	歯先円直径 Outside Diameter da	形 Type	歯幅 Face Width b	穴径 Bore Diameter da(H7)	ハブ外径 Hub Diameter dh	ハブ長さ Hub Projection lh	全長 Overall Length l	キミぞ Key Way b2 × t2	ねじ Set Screw		リム内径 Dimension of Rim di	ウェブ厚さ Thickness of Web bw	重量 Weight W(kg)
											M	ls			
S2.5S 56A - 1616F	56	φ140	φ145	A1	16	φ16	-	-	16	-	-	-	-	-	1.91
S2.5S 56A - 2518F	56	φ140	φ145	A1	25	φ18	-	-	25	-	-	-	-	-	2.97
S2.5S 56B - 1618	56	φ140	φ145	B1	16	φ18	φ60	12	28	-	-	-	-	-	2.15
S2.5S 56B - 2520	56	φ140	φ145	B1	25	φ20	φ60	12	37	-	-	-	-	-	3.20
S2.5S 56B # 2525	56	φ140	φ145	B1	25	φ25	φ60	12	37	8 × 3.3	M6	6	-	-	3.14
S2.5S 60A - 1616F	60	φ150	φ155	A1	16	φ16	-	-	16	-	-	-	-	-	2.19
S2.5S 60A = 1625	60	φ150	φ155	A2	16	φ25	φ50	-	16	8 × 3.3	-	-	φ127	8	1.51
S2.5S 60A - 2518F	60	φ150	φ155	A1	25	φ18	-	-	25	-	-	-	-	-	3.42
S2.5S 60A = 2525	60	φ150	φ155	A2	25	φ25	φ50	-	25	8 × 3.3	-	-	φ127	13	2.42
S2.5S 60A = 2530	60	φ150	φ155	A2	25	φ30	φ60	-	25	8 × 3.3	-	-	φ127	13	2.46
S2.5S 60A = 2535	60	φ150	φ155	A2	25	φ35	φ70	-	25	10 × 3.3	-	-	φ127	13	2.51
S2.5S 60B - 1618	60	φ150	φ155	B1	16	φ18	φ60	12	28	-	-	-	-	-	2.43
S2.5S 60B # 1625	60	φ150	φ155	B3	16	φ25	φ60	12	28	8 × 3.3	M6	6	φ127	8	1.78
S2.5S 60BF - 2515	60	φ150	φ155	B1	25	φ15(H8)	φ105	20	45	-	-	-	-	-	4.75
S2.5S 60B - 2515H	60	φ150	φ155	B1	25	φ15(H※)	φ105	20	45	-	-	-	-	-	4.75
S2.5S 60B - 2520	60	φ150	φ155	B1	25	φ20	φ70	12	37	-	-	-	-	-	3.74
S2.5S 60B # 2525	60	φ150	φ155	B3	25	φ25	φ70	12	37	8 × 3.3	M6	6	φ127	13	2.91
S2.5S 60B # 2530	60	φ150	φ155	B3	25	φ30	φ70	12	37	8 × 3.3	M6	6	φ127	13	2.85
S2.5S 60B # 2535	60	φ150	φ155	B3	25	φ35	φ70	12	37	10 × 3.3	M8	6	φ127	13	2.77

●の商品は新商品です。Products with ● marks are new item.

【=】(イコール)にはキー材が付いております。【=】: Gear with key way / with key

【#】(シャープ)にはキー材とセットスクリューが付いております。【#】: Gear with key way and threaded hole / with key and screw.

カタログ記号の末尾に【H】を付した商品は歯部高周波焼入済です。Gear tooth surface completed with induction hardening, Hardness HRC47 to 53.

※
歯部高周波焼入後の穴修正は行っていません。Bore correcting after induction hardening is not completed.

追加加工の際は、追加加工時の注意をご参照ください。Please refer to Precaution for additional process when additional process.

許容伝達動力表 曲げ強さ (kW)

Allowable transfer capability table (W) Bending Strength

歯数 z	歯幅 b	焼入 H	回転速度 (min ⁻¹) revolution/min						
			10	100	200	400	800	1,200	1,500
56	16	-	0.31	3.06	5.71	9.47	17.11	24.44	-
56	25	-	0.48	4.77	8.92	14.80	26.73	38.19	-
60	16	-	0.33	3.32	6.12	10.16	18.41	26.56	-
60	25	-	0.52	5.19	9.56	15.87	28.76	41.50	-
60	25	-	0.520	5.160	9.500	15.790	28.600	41.270	-
60	25	○	0.547	5.469	10.148	17.102	32.086	48.129	-

The above references are JGMA standard.

動力の換算式はP26をご参照ください。Please refer to the conversion formulas of power on page P26.

許容伝達動力表 歯面強さ (kW)

Allowable transfer capability table (kW) Surface Durability

回転速度 (min ⁻¹) revolution/min						
10	100	200	400	800	1,200	1,500
-	-	-	-	-	-	-
-	-	-	-	-	-	-
-	-	-	-	-	-	-
0.056	0.570	1.070	1.850	3.640	5.570	-
0.247	2.735	5.231	9.088	17.575	26.836	-

目次
CONTENTS
インフォメーション
INFORMATION
ギヤボックス
GEAR BOXES
ノーマンバックス
ANTI BACKLASH SPUR GEARS
歯研研歯車
GROUND SPUR GEARS
歯研研歯車
SPUR GEARS
内歯車
INTERNAL GEARS
歯研研歯車
GROUND RACKS
ラック
RACKS
らせん歯車とスクリュー
HELIICAL GEARS AND SCREWS
ワームとワームホイール
WORMS AND WORM WHEELS
かみ歯車
BEVEL GEARS
スピロケット
SPIROKETS
技術データ
REFERENCE DATA

平歯車 SPUR GEARS

モジュール **2.5** 圧力角 20° (並歯) 歯数 64 ~ 72
 MODULE 20° PRESSURE ANGLE FULL DEPTH TOOTH Z 64 to Z 72

JIS B 1702-1 (ISO) 8級 (高周波焼入品: 9級)
 System of accuracy: JIS B 1702-1(ISO) class 8
 (Induction hardened products: class 9)



New 仕様変更 省スペース・軽量化、締結加工不要。
 Specification change Space-saving and weight saving.
 Additional machining on tightening is not necessary.

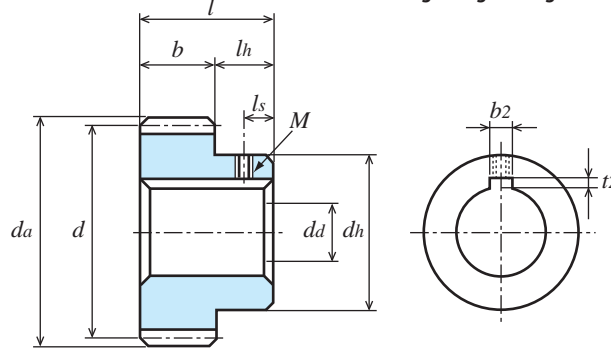

B1形
TYPE B1

S45C 機械構造用炭素鋼 (JIS G 4051) Material: Carbon Steel (ISO C45)

単位: mm
Dimensions: mm

商品記号 Catalogue Number	歯数 Number of Teeth z	基準円直径 Reference Diameter d	歯先円直径 Outside Diameter da	形 Type	歯幅 Face Width b	穴径 Bore Diameter da(H7)	ハブ外径 Hub Diameter dh	ハブ長さ Hub Projection lh	全長 Overall Length l	キミぞ Key Way b2 x t2	ねじ Set Screw		リム内径 Dimension of Rim di	ウエブ厚さ Thickness of Web bw	重量 Weight W(kg)
											M	ls			
S2.5S 64A - 1616F	64	φ160	φ165	A1	16	φ16	-	-	16	-	-	-	-	-	2.50
S2.5S 64A - 2518F	64	φ160	φ165	A1	25	φ18	-	-	25	-	-	-	-	-	3.90
S2.5S 64B - 1618	64	φ160	φ165	B1	16	φ18	φ 60	12	28	-	-	-	-	-	2.74
S2.5S 64B - 2520	64	φ160	φ165	B1	25	φ20	φ 70	12	37	-	-	-	-	-	4.22
S2.5S 64B # 2525	64	φ160	φ165	B3	25	φ25	φ 70	12	37	8 x 3.3	M6	6	φ137	13	3.20
S2.5S 70BF - 2520	70	φ175	φ180	B1	25	φ20	φ125	20	45	-	-	-	-	-	6.52
S2.5S 70B - 2520H	70	φ175	φ180	B1	25	φ20(H※)	φ125	20	45	-	-	-	-	-	6.52
S2.5S 72A - 1616F	72	φ180	φ185	A1	16	φ16	-	-	16	-	-	-	-	-	3.17
S2.5S 72A - 2518F	72	φ180	φ185	A1	25	φ18	-	-	25	-	-	-	-	-	4.94
S2.5S 72B - 1618	72	φ180	φ185	B1	16	φ18	φ 70	12	28	-	-	-	-	-	3.50
S2.5S 72B - 2520	72	φ180	φ185	B1	25	φ20	φ 70	12	37	-	-	-	-	-	5.27
S2.5S 72B # 2525	72	φ180	φ185	B3	25	φ25	φ 70	12	37	8 x 3.3	M6	6	φ157	13	3.82

●の商品は新商品です。Products with ● marks are new item.

【=】(イコール)にはキー材が付いております。 [=]: Gear with key way / with key
 【#】(シャープ)にはキー材とセットスクリューが付いております。 [#]: Gear with key way and threaded hole / with key and screw.

カタログ記号の末尾に【H】を付した商品は歯部高周波焼入済です。 Gear tooth surface completed with induction hardening, Hardness HRC47 to 53.

※
 歯部高周波焼入後の穴修正は行っていません。 Bore correcting after induction hardening is not completed.

追加加工の際は、追加加工時の注意をご参照ください。 Please refer to Precaution for additional process when additional process.

許容伝達動力表 曲げ強さ (kW)

Allowable transfer capability table (W) Bending Strength

歯数 z	歯幅 b	焼入 H	回転速度 (min ⁻¹) revolution/min						
			10	100	200	400	800	1,200	1,500
64	16	-	0.36	3.59	6.51	10.89	19.69	-	-
64	25	-	0.56	5.60	10.17	17.01	30.77	-	-
70	25	-	0.620	6.190	11.000	18.560	33.500	-	-
70	25	○	0.656	6.560	11.782	20.139	38.485	-	-
72	16	-	0.41	4.12	7.27	12.31	22.20	-	-
72	25	-	0.64	6.44	11.37	19.24	34.69	-	-

The above references are JGMA standard.

動力の換算式はP26をご参照ください。 Please refer to the conversion formulas of power on page P26.

許容伝達動力表 歯面強さ (kW)

Allowable transfer capability table (kW) Surface Durability

回転速度 (min ⁻¹) revolution/min						
10	100	200	400	800	1,200	1,500
-	-	-	-	-	-	-
-	-	-	-	-	-	-
0.078	0.790	1.430	2.540	5.020	-	-
0.341	3.777	6.994	12.323	24.275	-	-
-	-	-	-	-	-	-
-	-	-	-	-	-	-

平歯車

SPUR GEARS

モジュール **2.5** 圧力角 20° (並歯) 歯数 80
 MODULE 20° PRESSURE ANGLE FULL DEPTH TOOTH Z 80

JIS B 1702-1 (ISO) 8級 (高周波焼入品: 9級)
 System of accuracy: JIS B 1702-1(ISO) class 8
 (Induction hardened products: class 9)



御注文には必ず“フルネームで商品記号”を明記してください。
 Please refer to the catalogue reference while ordering.

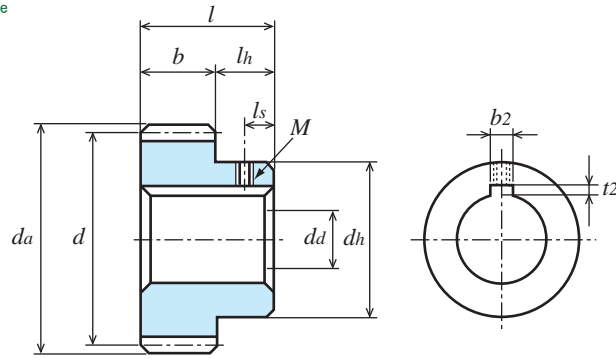

B1形
TYPE B1

S45C 機械構造用炭素鋼 (JIS G 4051) Material: Carbon Steel (ISO C45)

単位: mm
 Dimensions: mm

商品記号 Catalogue Number	歯数 Number of Teeth z	基準円直径 Reference Diameter d	歯先円直径 Outside Diameter da	形 Type	歯幅 Face Width b	穴径 Bore Diameter da(H7)	ハブ外径 Hub Diameter dh	ハブ長さ Hub Projection lh	全長 Overall Length l	キミぞ Key Way b2 × t2	ねじ Set Screw		リム内径 Dimension of Rim di	ウェブ厚さ Thickness of Web bw	重量 Weight W(kg)
											M	ls			
S2.5S 80A - 1618F	80	φ200	φ205	A1	16	φ18	-	-	16	-	-	-	-	3.91	
S2.5S 80A = 1625	80	φ200	φ205	A2	16	φ25	φ 50	-	16	8 × 3.3	-	φ177	8	2.50	
S2.5S 80A - 2520F	80	φ200	φ205	A1	25	φ20	-	-	25	-	-	-	-	6.10	
S2.5S 80A = 2525	80	φ200	φ205	A2	25	φ25	φ 50	-	25	8 × 3.3	-	φ177	13	4.02	
S2.5S 80A = 2530	80	φ200	φ205	A2	25	φ30	φ 60	-	25	8 × 3.3	-	φ177	13	4.06	
S2.5S 80A = 2535	80	φ200	φ205	A2	25	φ35	φ 70	-	25	10 × 3.3	-	φ177	13	4.10	
S2.5S 80B - 1618	80	φ200	φ205	B1	16	φ18	φ 60	12	28	-	-	-	-	4.16	
S2.5S 80B # 1625	80	φ200	φ205	B3	16	φ25	φ 60	12	28	8 × 3.3	M6	6	φ177	8	2.77
● S2.5S 80BF - 2520	80	φ200	φ205	B1	25	φ20	φ140	20	45	-	-	-	-	8.45	
● S2.5S 80B - 2520H	80	φ200	φ205	B1	25	φ20(H※)	φ140	20	45	-	-	-	-	8.45	
S2.5S 80B - 2522	80	φ200	φ205	B1	25	φ22	φ 70	12	37	-	-	-	-	6.42	
S2.5S 80B # 2525	80	φ200	φ205	B3	25	φ25	φ 70	12	37	8 × 3.3	M6	6	φ177	13	4.51
S2.5S 80B # 2530	80	φ200	φ205	B3	25	φ30	φ 70	12	37	8 × 3.3	M6	6	φ177	13	4.45
S2.5S 80B # 2535	80	φ200	φ205	B3	25	φ35	φ 70	12	37	10 × 3.3	M8	6	φ177	13	4.37

● の商品は新商品です。Products with ● marks are new item.

【=】(イコール)にはキー材が付いております。【=】: Gear with key way / with key

【#】(シャープ)にはキー材とセットスクリューが付いております。【#】: Gear with key way and threaded hole / with key and screw.

カタログ記号の末尾に【H】を付した商品は歯部高周波焼入済です。Gear tooth surface completed with induction hardening, Hardness HRC47 to 53.

※ 歯部高周波焼入後の穴修正は行っていません。Bore correcting after induction hardening is not completed.

追加加工の際は、追加加工時の注意をご参照ください。Please refer to Precaution for additional process when additional process.

許容伝達動力表 曲げ強さ (kW)

Allowable transfer capability table (W) Bending Strength

歯数 z	歯幅 b	焼入 H	回転速度 (min ⁻¹) revolution/min						
			10	100	200	400	800	1,200	1,500
80	16	-	0.47	4.62	8.00	13.70	24.84	-	-
80	25	-	0.720	7.170	12.410	21.260	38.530	-	-
80	25	○	0.766	7.610	13.328	23.090	44.931	-	-

The above references are JGMA standard.

動力の換算式はP26をご参照ください。Please refer to the conversion formulas of power on page P26.

許容伝達動力表 歯面強さ (kW)

Allowable transfer capability table (kW) Surface Durability

回転速度 (min ⁻¹) revolution/min							
10	100	200	400	800	1,200	1,500	
-	-	-	-	-	-	-	-
0.103	1.040	1.850	3.330	6.680	-	-	-
0.452	4.965	8.964	16.008	32.111	-	-	-

平歯車

SPUR GEARS

モジュール
MODULE

3

圧力角 20° (並歯)
20° PRESSURE ANGLE FULL DEPTH TOOTH

JIS B 1702-1 (ISO) 9~10 級
System of accuracy : JIS B 1702-1(ISO) class 9-10



New 仕様変更 省スペース・軽量化。
Specification change Space-saving and weight saving.

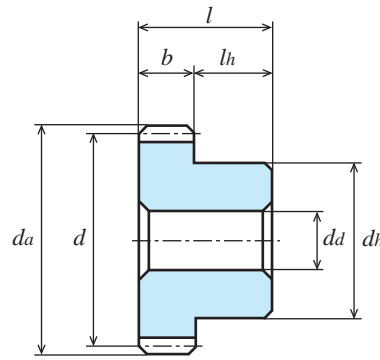

B1形
TYPE B1

ポリアセタール (黒色)
Material : Poly Acetal (Black)

単位 : mm
Dimensions : mm

商品記号 Catalogue Number	歯数 Number of Teeth z	基準円直径 Reference Diameter d	歯先円直径 Tip Diameter da	形 Type	歯幅 Face Width b	穴径 Bore Diameter da	ハブ外径 Hub Diameter dh	ハブ長さ Hub Projection lh	全長 Overall Length l	重量 Weight $W(g)$
▲ S3D 14B - 3016N	14	φ 42	φ 48	B1	30	φ16	φ34	13	43	63.1
▲ S3D 15B - 3016N	15	φ 45	φ 51	B1	30	φ16	φ36	13	43	73.7
▲ S3D 16B - 3016N	16	φ 48	φ 54	B1	30	φ16	φ40	13	43	87.4
▲ S3D 18B - 3018N	18	φ 54	φ 60	B1	30	φ18	φ46	13	43	111.9
▲ S3D 20B - 3018N	20	φ 60	φ 66	B1	30	φ18	φ52	13	43	143.1
▲ S3D 24B - 3020N	24	φ 72	φ 78	B1	30	φ20	φ56	13	43	198.3
▲ S3D 25B - 3020N	25	φ 75	φ 81	B1	30	φ20	φ56	13	43	213.0
▲ S3D 28B - 3020N	28	φ 84	φ 90	B1	30	φ20	φ60	13	43	267.2
▲ S3D 30B - 3020N	30	φ 90	φ 96	B1	30	φ20	φ60	13	43	301.9
▲ S3D 32B - 3020N	32	φ 96	φ102	B1	30	φ20	φ80	13	43	379.3
▲ S3D 35B - 3020N	35	φ105	φ111	B1	30	φ20	φ80	13	43	439.4
▲ S3D 36B - 3020N	36	φ108	φ114	B1	30	φ20	φ80	13	43	460.6

▲の商品は2017年5月20日をもってカタログ商品(規格品)としての生産を中止とします。米国・EU市場の食品接触用途・規制に適合した青 POM[®] ギヤシリーズをご利用ください。Products with ▲ mark will be terminated with effective 20th May 2017. Alternative products are indicated on separate catalogue of Blue Poly Acetal gears which adapted to relevant regulations for the food industries in the US and EU markets.

許容伝達動力表 曲げ強さ (W)

Allowable transfer capability table (W) Bending Strength

商品記号 Catalogue Numbers	回転速度 (min ⁻¹) revolution/min						
	10	100	200	400	800	1,200	1,500
S3D 14B - 3016	6.85	68.38	136.59	272.49	542.23	808.24	1,000.62
S3D 15B - 3016	7.33	73.26	146.32	291.85	580.54	863.60	1,068.39
S3D 16B - 3016	7.82	78.14	156.05	311.19	618.79	918.64	1,135.66
S3D 18B - 3018	8.80	87.89	175.49	349.84	695.13	1,027.78	1,268.73
S3D 20B - 3018	9.78	97.63	194.92	388.43	771.16	1,135.66	1,399.82
S3D 24B - 3020	11.73	117.12	233.73	465.44	918.69	1,347.62	1,649.49
S3D 25B - 3020	12.22	121.99	243.43	484.66	955.16	1,399.82	1,709.58
S3D 28B - 3020	13.69	136.59	272.49	542.23	1,063.88	1,551.92	1,885.69
S3D 30B - 3020	14.67	146.32	291.85	580.54	1,135.66	1,649.49	1,999.64
S3D 32B - 3020	15.65	156.05	311.19	618.79	1,206.88	1,745.30	2,110.03
S3D 35B - 3020	17.11	170.63	340.19	676.07	1,312.65	1,885.69	2,255.99
S3D 36B - 3020	17.60	175.49	349.84	695.13	1,347.62	1,931.61	2,302.67

The above numerical values are Lewis formulas as reference only.

動力の換算式は P26 をご参照ください。

Please refer to the conversion formulas of power on page P26.

JIS B 1702-1 (ISO) 9~10 級
System of accuracy : JIS B 1702-1(ISO) class 9-10



御注文には必ず“フルネームで商品記号”を明記してください。
Please refer to the catalogue reference while ordering.

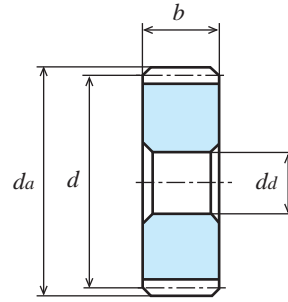

A1形
TYPE A1

ポリアセタール (黒色) Material : Poly Acetal (Black)

単位 : mm
Dimensions : mm

商品記号 Catalogue Number	歯数 Number of Teeth z	基準円直径 Reference Diameter d	歯先円直径 Tip Diameter d_a	形 Type	歯幅 Face Width b	穴径 Bore Diameter d_a	ハブ外径 Hub Diameter d_h	ハブ長さ Hub Projection l_h	全長 Overall Length l	重量 Weight $W(g)$
▲ S3D 40A - 3020	40	φ120	φ126	A1	30	φ20	-	-	30	465.1
▲ S3D 45A - 3020	45	φ135	φ141	A1	30	φ20	-	-	30	592.2
▲ S3D 48A - 3020	48	φ144	φ150	A1	30	φ20	-	-	30	675.6
▲ S3D 50A - 3020	50	φ150	φ156	A1	30	φ20	-	-	30	734.2
▲ S3D 56A - 3020	56	φ168	φ174	A1	30	φ20	-	-	30	924.4
▲ S3D 60A - 3020	60	φ180	φ186	A1	30	φ20	-	-	30	1,063.0
▲ S3D 64A - 3020	64	φ192	φ198	A1	30	φ20	-	-	30	1,211.0

▲の商品は2017年5月20日をもってカタログ商品(規格品)としての生産を中止とします。米国・EU市場の食品接触用途・規制に適合した青 POM® ギヤシリーズをご利用ください。Products with ▲ mark will be terminated with effective 20th May 2017. Alternative products are indicated on separate catalogue of Blue Poly Acetal gears which adapted to relevant regulations for the food industries in the US and EU markets.

許容伝達動力表 曲げ強さ (W)

Allowable transfer capability table (W) Bending Strength

商品記号 Catalogue Numbers	回転速度 (min ⁻¹) revolution/min						
	10	100	200	400	800	1,200	1,500
S3D 40A - 3020	19.56	194.92	388.43	771.16	1,485.88	2,110.03	2,479.51
S3D 45A - 3020	22.00	219.18	436.59	863.60	1,649.49	2,302.67	-
S3D 48A - 3020	23.46	233.73	465.44	918.64	1,745.30	2,410.67	-
S3D 50A - 3020	24.44	243.43	484.66	955.16	1,808.19	2,479.51	-
S3D 56A - 3020	27.37	272.49	542.23	1,063.88	1,992.13	-	-
S3D 60A - 3020	29.33	291.85	580.54	1,135.66	2,110.03	-	-
S3D 64A - 3020	31.28	311.19	618.79	1,206.88	2,214.74	-	-

The above numerical values are Lewis formulas as reference only.

動力の換算式は P26 をご参照ください。

Please refer to the conversion formulas of power on page P26.

平歯車 SPUR GEARS

モジュール
MODULE

3

圧力角 20° (並歯) 歯数 14 ~ 15
20° PRESSURE ANGLE FULL DEPTH TOOTH Z 14 to Z 15

JIS B 1702-1 (ISO) 8級~9級
System of accuracy : JIS B 1702-1(ISO) class 8-9



New 仕様変更 省スペース・軽量化。
Specification change Space-saving and weight saving.

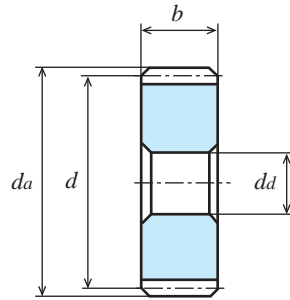

A1形
TYPE A1

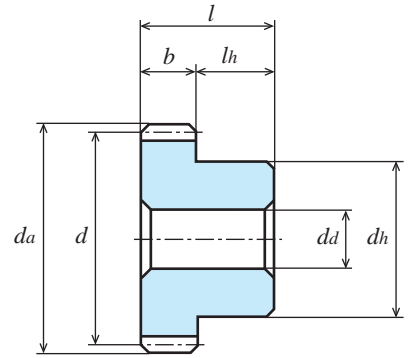

B1形
TYPE B1

S45C 機械構造用炭素鋼 (JIS G 4051) Material : Carbon Steel (ISO C45)

単位 : mm
Dimensions : mm

商品記号 Catalogue Number	歯数 Number of Teeth z	基準円直径 Reference Diameter d	歯先円直径 Tip Diameter d_a	形 Type	歯幅 Face Width b	穴径 Bore Diameter $d_d(H7)$	ハブ外径 Hub Diameter d_h	ハブ長さ Hub Projection l_h	全長 Overall Length l	重量 Weight $W(kg)$
S3S 14A - 2216	14	φ42	φ48	A1	22	φ16	-	-	22	0.20
S3S 14A - 3016	14	φ42	φ48	A1	30	φ16	-	-	30	0.28
S3S 14A - 3516	14	φ42	φ48	A1	35	φ16	-	-	35	0.33
S3S 14B - 2216N	14	φ42	φ48	B1	22	φ16	φ34	13	35	0.28
S3S 14B - 3016N	14	φ42	φ48	B1	30	φ16	φ34	13	43	0.35
S3S 14B - 3516N	14	φ42	φ48	B1	35	φ16(H8)	φ34	13	48	0.40
S3S 15A - 2216	15	φ45	φ51	A1	22	φ16	-	-	22	0.24
S3S 15A - 3016	15	φ45	φ51	A1	30	φ16	-	-	30	0.33
S3S 15A - 3516	15	φ45	φ51	A1	35	φ16	-	-	35	0.38
S3S 15B - 2216N	15	φ45	φ51	B1	22	φ16	φ36	13	35	0.32
S3S 15B - 3016N	15	φ45	φ51	B1	30	φ16	φ36	13	43	0.41
S3S 15B - 3516N	15	φ45	φ51	B1	35	φ16(H8)	φ36	13	48	0.47

許容伝達動力表 曲げ強さ (kW)

T (N · m)

Allowable transfer capability table (W) Bending Strength

歯数 z	歯幅 b	回転速度 (min ⁻¹) revolution/min							回転速度 (min ⁻¹) revolution/min
		10	100	200	400	800	1,200	1,500	100
14	22	0.087	0.88	1.75	3.51	6.29	8.44	10.00	84.03
14	30	0.120	1.20	2.39	4.78	8.58	11.51	13.63	114.59
14	35	0.139	1.39	2.79	5.58	10.01	13.43	15.91	132.74
15	22	0.098	0.98	1.96	3.93	6.94	9.25	11.10	93.58
15	30	0.134	1.34	2.68	5.36	9.46	12.61	15.14	127.96
15	35	0.156	1.56	3.13	6.25	11.04	14.72	17.67	148.97

The above numerical values are equivalent to JGMA formulas as reference only.

動力の換算式は P26 をご参照ください。Please refer to the conversion fomulas of power on page P26.

JIS B 1702-1 (ISO) 8 級
System of accuracy : JIS B 1702-1(ISO) class 8

御注文には必ず“フルネームで商品記号”を明記してください。
Please refer to the catalogue reference while ordering.

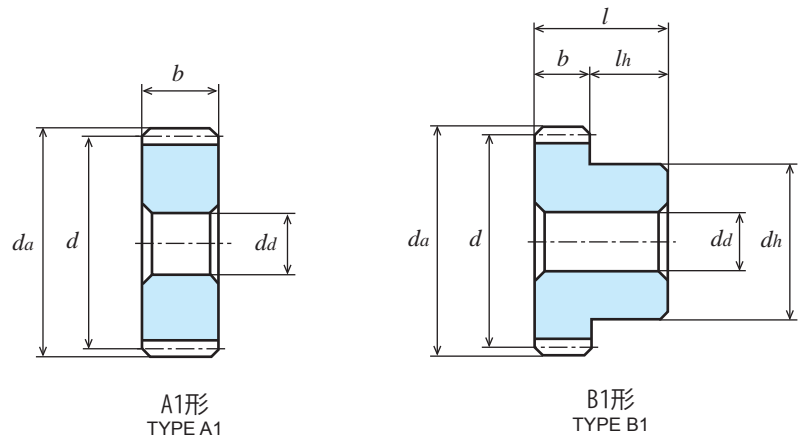

S45C 機械構造用炭素鋼 (JIS G 4051)

Material : Carbon Steel (ISO C45)

単位 : mm
Dimensions : mm

商品記号 Catalogue Number	歯数 Number of Teeth <i>z</i>	基準円直径 Reference Diameter <i>d</i>	歯先円直径 Tip Diameter <i>da</i>	形 Type	歯幅 Face Width <i>b</i>	穴径 Bore Diameter <i>da</i> (H7)	ハブ外径 Hub Diameter <i>dh</i>	ハブ長さ Hub Projection <i>lh</i>	全長 Overall Length <i>l</i>	重量 Weight <i>W</i> (kg)
S3S 16A - 2216	16	φ48	φ54	A1	22	φ16	-	-	22	0.28
S3S 16A - 3016	16	φ48	φ54	A1	30	φ16	-	-	30	0.38
S3S 16A - 3516	16	φ48	φ54	A1	35	φ16	-	-	35	0.44
S3S 16B - 2216N	16	φ48	φ54	B1	22	φ16	φ40	13	35	0.39
S3S 16B - 3016N	16	φ48	φ54	B1	30	φ16	φ40	13	43	0.49
S3S 16B - 3516N	16	φ48	φ54	B1	35	φ16(H8)	φ40	13	48	0.55
S3S 18A - 2216	18	φ54	φ60	A1	22	φ16	-	-	22	0.36
S3S 18A - 3016	18	φ54	φ60	A1	30	φ16	-	-	30	0.49
S3S 18A - 3518	18	φ54	φ60	A1	35	φ18	-	-	35	0.56
S3S 18B - 2218N	18	φ54	φ60	B1	22	φ18	φ46	13	35	0.50
S3S 18B - 3018N	18	φ54	φ60	B1	30	φ18	φ46	13	43	0.62
S3S 18B - 3516N	18	φ54	φ60	B1	35	φ16(H8)	φ46	13	48	0.70

許容伝達動力表 曲げ強さ (kW)

T (N · m)

Allowable transfer capability table (W) Bending Strength

歯数 <i>z</i>	歯幅 <i>b</i>	回転速度 (min ⁻¹) revolution/min							回転速度 (min ⁻¹) revolution/min
		10	100	200	400	800	1,200	1,500	100
16	22	0.11	1.09	2.18	4.36	7.57	10.06	12.22	104.09
16	30	0.15	1.49	2.97	5.94	10.33	13.71	16.66	142.29
16	35	0.17	1.73	3.47	6.93	12.05	16.00	19.43	165.21
18	22	0.13	1.31	2.62	5.14	8.81	11.91	14.43	125.10
18	30	0.18	1.79	3.57	7.01	12.02	16.25	19.68	170.93
18	35	0.21	2.08	4.17	8.18	14.02	18.96	22.96	198.63

KG 規格は“並幅” (軽荷重用) と“広幅” (重荷重用) があります。ご用途に応じてお選び下さい。

KG STOCK GEARS has Wide-face width for Heavy load, and Standard-face width for Light load.

You are able to multiple choices for your suitable design from our wide range.

The above numerical values are equivalent to JGMA formulas as reference only.

動力の換算式は P26 をご参照ください。Please refer to the conversion fomulas of power on page P26.

平歯車 SPUR GEARS

モジュール
MODULE

3

圧力角 20° (並歯) 歯数 20

20° PRESSURE ANGLE FULL DEPTH TOOTH Z 20

JIS B 1702-1 (ISO) 8 級 (高周波焼入品: 9 級)
System of accuracy: JIS B 1702-1(ISO) class 8
(Induction hardened products: class 9)



仕様変更 省スペース・軽量化、締結加工不要。

Specification change Space-saving and weight saving.
Additional machining on tightening is not necessary.

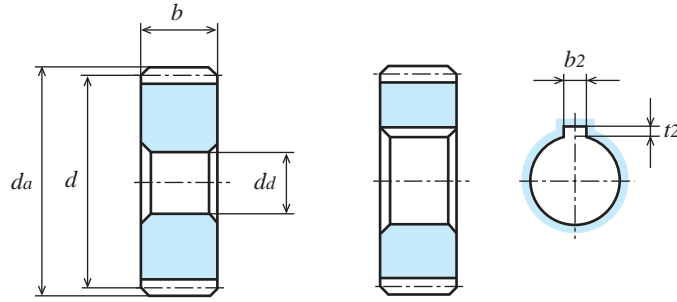

A1形
TYPE A1

A1形
TYPE A1

S45C 機械構造用炭素鋼 (JIS G 4051) Material: Carbon Steel (ISO C45)

単位: mm
Dimensions: mm

商品記号 Catalogue Number	歯数 Number of Teeth z	基準円直径 Reference Diameter d	歯先円直径 Outside Diameter da	形 Type	歯幅 Face Width b	穴径 Bore Diameter da(H7)	ハブ外径 Hub Diameter dh	ハブ長さ Hub Projection lh	全長 Overall Length l	キミぞ Key Way b2 × t2	ねじ Set Screw		リム内径 Dimension of Rim di	ウェブ厚さ Thickness of Web bw	重量 Weight W(kg)
											M	ls			
S3S 20A - 2216F	20	φ60	φ66	A1	22	φ16	-	-	22	-	-	-	-	-	0.45
S3S 20A = 2220	20	φ60	φ66	A1	22	φ20	-	-	22	6 × 2.8	-	-	-	-	0.43
S3S 20A - 3018F	20	φ60	φ66	A1	30	φ18	-	-	30	-	-	-	-	-	0.61
S3S 20A - 3518F	20	φ60	φ66	A1	35	φ18	-	-	35	-	-	-	-	-	0.71
S3S 20A = 3525	20	φ60	φ66	A1	35	φ25	-	-	35	8 × 3.3	-	-	-	-	0.63
S3S 20B - 2218	20	φ60	φ66	B1	22	φ18	φ40	13	35	-	-	-	-	-	0.55
S3S 20B # 2220	20	φ60	φ66	B1	22	φ20	φ40	13	35	6 × 2.8	M5	6.5	-	-	0.53
● S3S 20BF - 3012	20	φ60	φ66	B1	30	φ12(H8)	φ52	20	50	-	-	-	-	-	0.92
● S3S 20B - 3012H	20	φ60	φ66	B1	30	φ12(H※)	φ52	20	50	-	-	-	-	-	0.92
S3S 20B - 3018N	20	φ60	φ66	B1	30	φ18	φ52	13	43	-	-	-	-	-	0.80
S3S 20B - 3516	20	φ60	φ66	B1	35	φ16(H8)	φ50	13	48	-	-	-	-	-	0.90
S3S 20B # 3525	20	φ60	φ66	B1	35	φ25	φ50	13	48	8 × 3.3	M6	6.5	-	-	0.78

●の商品は新商品です。Products with ● marks are new item.

【=】(イコール)にはキー材が付いております。 [=]: Gear with key way / with key

【#】(シャープ)にはキー材とセットスクリューが付いております。 [#]: Gear with key way and threaded hole / with key and screw.

カタログ記号の末尾に【H】を付した商品は歯部高周波焼入済です。 Gear tooth surface completed with induction hardening, Hardness HRC47 to 53.

※
歯部高周波焼入後の穴修正は行っていません。 Bore correcting after induction hardening is not completed.

追加加工の際は、追加加工時の注意をご参照ください。 Please refer to Precaution for additional process when additional process.

許容伝達動力表 曲げ強さ (kW)

Allowable transfer capability table (W) Bending Strength

歯数 z	歯幅 b	焼入 H	回転速度 (min ⁻¹) revolution/min						
			10	100	200	400	800	1,200	1,500
20	22	-	0.15	1.54	3.08	5.93	10.03	13.79	16.65
20	30	-	0.210	2.110	4.230	8.140	13.780	18.950	22.880
20	30	○	0.224	2.240	4.481	8.659	14.857	20.558	24.882
20	35	-	0.24	2.45	4.90	9.43	15.96	21.94	26.50

The above references are JGMA standard.

動力の換算式は P26 をご参照ください。 Please refer to the conversion formulas of power on page P26.

許容伝達動力表 歯面強さ (kW)

Allowable transfer capability table (kW) Surface Durability

回転速度 (min ⁻¹) revolution/min						
10	100	200	400	800	1,200	1,500
-	-	-	-	-	-	-
0.010	0.100	0.200	0.390	0.680	0.960	1.190
0.044	0.481	0.992	1.977	3.496	4.924	6.019
-	-	-	-	-	-	-

平歯車 SPUR GEARS

モジュール
MODULE

3

圧力角 20° (並歯) 歯数 24

20° PRESSURE ANGLE FULL DEPTH TOOTH Z 24

JIS B 1702-1 (ISO) 8級
System of accuracy : JIS B 1702-1(ISO) class 8



御注文には必ず“フルネームで商品記号”を明記してください。

Please refer to the catalogue reference while ordering.

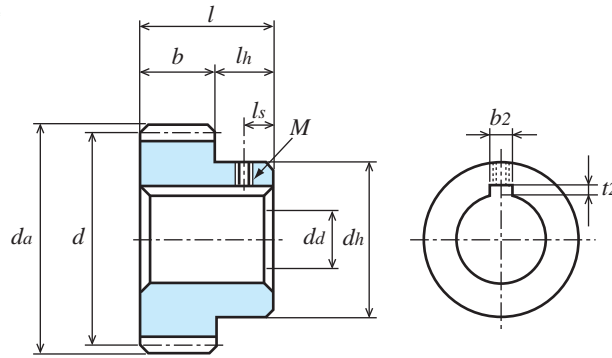

B1形
TYPE B1

S45C 機械構造用炭素鋼 (JIS G 4051) Material : Carbon Steel (ISO C45)

単位 : mm
Dimensions : mm

商品記号 Catalogue Number	歯数 Number of Teeth z	基準円直径 Reference Diameter d	歯先円直径 Outside Diameter da	形 Type	歯幅 Face Width b	穴径 Bore Diameter da(H7)	ハブ 外径 Hub Diameter dh	ハブ 長さ Hub Projection lh	全長 Overall Length l	キー みぞ Key Way b2 × t2	ねじ Set Screw		リム内径 Dimension of Rim di	ウエブ 厚さ Thickness of Web bw	重量 Weight W(kg)
											M	ls			
S3S 24A - 2216F	24	φ72	φ78	A1	22	φ16	-	-	22	-	-	-	-	0.67	
S3S 24A = 2220	24	φ72	φ78	A1	22	φ20	-	-	22	6 × 2.8	-	-	-	0.65	
S3S 24A = 2225	24	φ72	φ78	A1	22	φ25	-	-	22	8 × 3.3	-	-	-	0.61	
S3S 24A - 3018F	24	φ72	φ78	A1	30	φ18	-	-	30	-	-	-	-	0.90	
S3S 24A - 3518F	24	φ72	φ78	A1	35	φ18	-	-	35	-	-	-	-	1.05	
S3S 24A = 3525	24	φ72	φ78	A1	35	φ25	-	-	35	8 × 3.3	-	-	-	0.98	
S3S 24A = 3530	24	φ72	φ78	A1	35	φ30	-	-	35	8 × 3.3	-	-	-	0.92	
S3S 24B - 2218	24	φ72	φ78	B1	22	φ18	φ50	13	35	-	-	-	-	0.83	
S3S 24B # 2220	24	φ72	φ78	B1	22	φ20	φ50	13	35	6 × 2.8	M5	6.5	-	0.81	
S3S 24B # 2225	24	φ72	φ78	B1	22	φ25	φ50	13	35	8 × 3.3	M6	6.5	-	0.76	
S3S 24B - 3020N	24	φ72	φ78	B1	30	φ20	φ60	13	43	-	-	-	-	1.14	
S3S 24B - 3518	24	φ72	φ78	B1	35	φ18	φ60	13	48	-	-	-	-	1.31	
S3S 24B # 3525	24	φ72	φ78	B1	35	φ25	φ60	13	48	8 × 3.3	M6	6.5	-	1.21	
S3S 24B # 3530	24	φ72	φ78	B1	35	φ30	φ60	13	48	8 × 3.3	M6	6.5	-	1.13	

【=】 (イコール) にはキー材が付いております。 [=]: Gear with key way / with key

【#】 (シャープ) にはキー材とセットスクリューが付いております。 [#]: Gear with key way and threaded hole / with key and screw.

許容伝達動力表 曲げ強さ (kW)

T (N · m)

Allowable transfer capability table (W) Bending Strength

歯数 z	歯幅 b	回転速度 (min ⁻¹) revolution/min							回転速度 (min ⁻¹) revolution/min
		10	100	200	400	800	1,200	1,500	
24	22	0.20	2.01	4.01	7.45	12.33	17.49	21.16	100
24	30	0.27	2.73	5.47	10.17	16.82	23.85	28.85	191.94
24	35	0.32	3.19	6.38	11.86	19.62	27.82	33.66	260.70
									304.63

KG 規格は“並幅”(軽荷重用)と“広幅”(重荷重用)があります。ご用途に応じてお選び下さい。

KG STOCK GEARS has Wide-face width for Heavy load, and Standard-face width for Light load.

You are able to multiple choices for your suitable design from our wide range.

The above numerical values are equivalent to JGMA formulas as reference only.

動力の換算式は P26 をご参照ください。Please refer to the conversion fomulas of power on page P26.

目次
CONTENTS

インフォメーション
INFORMATION

ギヤボックス
GEAR BOXES

ノーバッキングバックラッシュギヤ
ANTI BACKLASH SPUR GEARS

歯研平歯車
GROUND SPUR GEARS

平歯車
SPUR GEARS

内歯車
INTERNAL GEARS

歯研ラック
GROUND RACKS

ラック
RACKS

ひかり・スクリューギヤ
HELICAL GEARS AND SCREW GEARS

ワーム・ワームホイール
WORMS AND WORM WHEELS

かさ歯車
BEVEL GEARS

スプロケット
SPROCKETS

技術資料
REFERENCE DATA

平歯車

SPUR GEARS

モジュール
MODULE

3

圧力角 20° (並歯) 歯数 25
20° PRESSURE ANGLE FULL DEPTH TOOTH Z 25

JIS B 1702-1 (ISO) 8級 (高周波焼入品: 9級)
System of accuracy: JIS B 1702-1(ISO) class 8
(Induction hardened products: class 9)



仕様変更 省スペース・軽量化、締結加工不要。
Specification change Space-saving and weight saving.
Additional machining on tightening is not necessary.

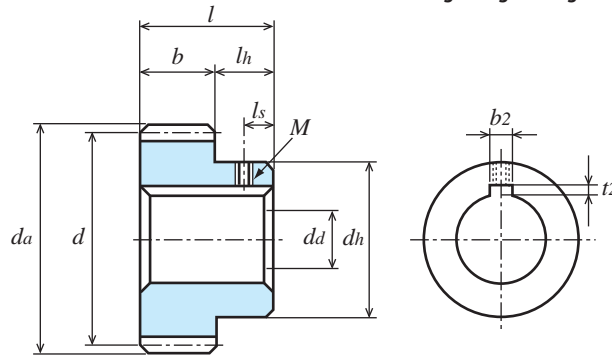

B1形
TYPE B1

S45C 機械構造用炭素鋼 (JIS G 4051) Material: Carbon Steel (ISO C45)

単位: mm
Dimensions: mm

商品記号 Catalogue Number	歯数 Number of Teeth z	基準円直径 Reference Diameter d	歯先円直径 Outside Diameter da	形 Type	歯幅 Face Width b	穴径 Bore Diameter da(H7)	ハブ外径 Hub Diameter dh	ハブ長さ Hub Projection lh	全長 Overall Length l	キミぞ Key Way b2 × t2	ねじ Set Screw		リム内径 Dimension of Rim di	ウェブ厚さ Thickness of Web bw	重量 Weight W(kg)
											M	ls			
S3S 25A - 2218F	25	φ75	φ81	A1	22	φ18	-	-	22	-	-	-	-	0.72	
S3S 25A = 2225	25	φ75	φ81	A1	22	φ25	-	-	22	8 × 3.3	-	-	-	0.67	
S3S 25A - 3018F	25	φ75	φ81	A1	30	φ18	-	-	30	-	-	-	-	0.98	
S3S 25A - 3520F	25	φ75	φ81	A1	35	φ20	-	-	35	-	-	-	-	1.13	
S3S 25A = 3525	25	φ75	φ81	A1	35	φ25	-	-	35	8 × 3.3	-	-	-	1.07	
S3S 25A = 3530	25	φ75	φ81	A1	35	φ30	-	-	35	8 × 3.3	-	-	-	1.01	
S3S 25B - 2220	25	φ75	φ81	B1	22	φ20	φ50	13	35	-	-	-	-	0.88	
S3S 25B # 2225	25	φ75	φ81	B1	22	φ25	φ50	13	35	8 × 3.3	M6	6.5	-	0.82	
● S3S 25BF - 3012	25	φ75	φ81	B1	30	φ12(H8)	φ60	20	50	-	-	-	-	1.43	
● S3S 25B - 3012H	25	φ75	φ81	B1	30	φ12(H※)	φ60	20	50	-	-	-	-	1.43	
S3S 25B - 3020N	25	φ75	φ81	B1	30	φ20	φ60	13	43	-	-	-	-	1.22	
S3S 25B - 3518	25	φ75	φ81	B1	35	φ18	φ60	13	48	-	-	-	-	1.41	
S3S 25B # 3525	25	φ75	φ81	B1	35	φ25	φ60	13	48	8 × 3.3	M6	6.5	-	1.31	
S3S 25B # 3530	25	φ75	φ81	B1	35	φ30	φ60	13	48	8 × 3.3	M6	6.5	-	1.22	

● の商品は新商品です。Products with ● marks are new item.

【=】(イコール)にはキー材が付いております。【=】: Gear with key way / with key

【#】(シャープ)にはキー材とセットスクリューが付いております。【#】: Gear with key way and threaded hole / with key and screw.

カタログ記号の末尾に【H】を付した商品は歯部高周波焼入済です。Gear tooth surface completed with induction hardening, Hardness HRC47 to 53.

※
歯部高周波焼入後の穴修正は行っていません。Bore correcting after induction hardening is not completed.

追加加工の際は、追加加工時の注意をご参照ください。Please refer to Precaution for additional process when additional process.

許容伝達動力表 曲げ強さ (kW)

Allowable transfer capability table (W) Bending Strength

歯数 z	歯幅 b	焼入 H	回転速度 (min ⁻¹) revolution/min						
			10	100	200	400	800	1,200	1,500
25	22	-	0.21	2.12	4.25	7.83	13.01	18.40	22.29
25	30	-	0.290	2.910	5.820	10.710	17.800	25.180	30.510
25	30	○	0.308	3.083	6.166	11.441	19.280	27.391	33.911
25	35	-	0.34	3.38	6.76	12.46	20.69	29.28	35.47

The above references are JGMA standard.

動力の換算式はP26をご参照ください。Please refer to the conversion formulas of power on page P26.

許容伝達動力表 歯面強さ (kW)

Allowable transfer capability table (kW) Surface Durability

回転速度 (min ⁻¹) revolution/min						
10	100	200	400	800	1,200	1,500
-	-	-	-	-	-	-
0.016	0.160	0.320	0.600	1.030	1.520	1.900
0.069	0.768	1.584	3.029	5.262	7.610	9.514
-	-	-	-	-	-	-

平歯車

SPUR GEARS

モジュール
MODULE

3

圧力角 20° (並歯) 歯数 28
20° PRESSURE ANGLE FULL DEPTH TOOTH Z 28

JIS B 1702-1 (ISO) 8 級
System of accuracy : JIS B 1702-1(ISO) class 8



御注文には必ず“フルネームで商品記号”を明記してください。
Please refer to the catalogue reference while ordering.

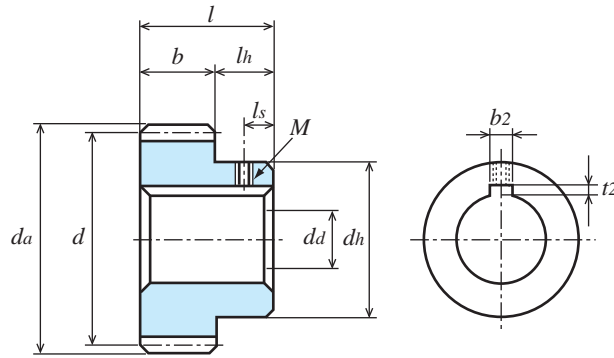

B1形
TYPE B1

S45C 機械構造用炭素鋼 (JIS G 4051) Material : Carbon Steel (ISO C45)

単位 : mm
Dimensions : mm

商品記号 Catalogue Number	歯数 Number of Teeth z	基準円直径 Reference Diameter d	歯先円直径 Outside Diameter da	形 Type	歯幅 Face Width b	穴径 Bore Diameter da(H7)	ハブ外径 Hub Diameter dh	ハブ長さ Hub Projection lh	全長 Overall Length l	キーマゾ Key Way b2 × t2	ねじ Set Screw		リム内径 Dimension of Rim di	ウェブ厚さ Thickness of Web bw	重量 Weight W(kg)
											M	ls			
S3S 28A - 2218F	28	φ84	φ90	A1	22	φ18	-	-	22	-	-	-	-	0.91	
S3S 28A = 2225	28	φ84	φ90	A1	22	φ25	-	-	22	8 × 3.3	-	-	-	0.87	
S3S 28A - 3020F	28	φ84	φ90	A1	30	φ20	-	-	30	-	-	-	-	1.23	
S3S 28A - 3520F	28	φ84	φ90	A1	35	φ20	-	-	35	-	-	-	-	1.44	
S3S 28A = 3525	28	φ84	φ90	A1	35	φ25	-	-	35	8 × 3.3	-	-	-	1.38	
S3S 28A = 3530	28	φ84	φ90	A1	35	φ30	-	-	35	8 × 3.3	-	-	-	1.32	
S3S 28B - 2220	28	φ84	φ90	B1	22	φ20	φ50	13	35	-	-	-	-	1.07	
S3S 28B # 2225	28	φ84	φ90	B1	22	φ25	φ50	13	35	8 × 3.3	M6	6.5	-	1.01	
S3S 28B - 3022N	28	φ84	φ90	B1	30	φ22	φ60	13	43	-	-	-	-	1.47	
S3S 28B - 3518	28	φ84	φ90	B1	35	φ18	φ60	13	48	-	-	-	-	1.72	
S3S 28B # 3525	28	φ84	φ90	B1	35	φ25	φ60	13	48	8 × 3.3	M6	6.5	-	1.61	
S3S 28B # 3530	28	φ84	φ90	B1	35	φ30	φ60	13	48	8 × 3.3	M6	6.5	-	1.53	

【=】(イコール)にはキー材が付いております。【=】: Gear with key way / with key

【#】(シャープ)にはキー材とセットスクリューが付いております。【#】: Gear with key way and threaded hole / with key and screw.

許容伝達動力表 曲げ強さ (kW)

T (N · m)

Allowable transfer capability table (W) Bending Strength

歯数 z	歯幅 b	回転速度 (min ⁻¹) revolution/min							回転速度 (min ⁻¹) revolution/min
		10	100	200	400	800	1,200	1,500	
28	22	0.25	2.49	4.98	8.93	15.01	21.18	25.68	100
28	30	0.34	3.39	6.78	12.18	20.47	28.89	35.02	237.78
28	35	0.40	3.96	7.92	14.21	23.88	33.70	40.85	323.73
									378.16

KG 規格は“並幅”(軽荷重用)と“広幅”(重荷重用)があります。ご用途に応じてお選び下さい。

KG STOCK GEARS has Wide-face width for Heavy load, and Standard-face width for Light load.

You are able to multiple choices for your suitable design from our wide range.

The above numerical values are equivalent to JGMA formulas as reference only.

動力の換算式は P26 をご参照ください。Please refer to the conversion fomulas of power on page P26.

目次
CONTENTS

インフォメーション
INFORMATION

ギヤボックス
GEAR BOXES

ノーバッキングバックラッシュギヤ
ANTI BACKLASH SPUR GEARS

歯研平歯車
GROUND SPUR GEARS

平歯車
SPUR GEARS

内歯車
INTERNAL GEARS

歯研ラック
GROUND RACKS

ラック
RACKS

ハニカム・スチールギヤ
HELICAL GEARS AND STEEL GEARS

ウォーム・ウォームホイール
WORMS AND WORM WHEELS

かさ歯車
BEVEL GEARS

スプロケット
SPROCKETS

技術資料
REFERENCE DATA

平歯車 SPUR GEARS

モジュール
MODULE

3

圧力角 20° (並歯) 歯数 30
20° PRESSURE ANGLE FULL DEPTH TOOTH Z30

JIS B 1702-1 (ISO) 8級 (高周波焼入品: 9級)
System of hardening: JIS B 1702-1(ISO) class 8
(Induction hardened products: class 9)



仕様変更 省スペース・軽量化、締結加工不要。
Specification change Space-saving and weight saving.
Additional machining on tightening is not necessary.

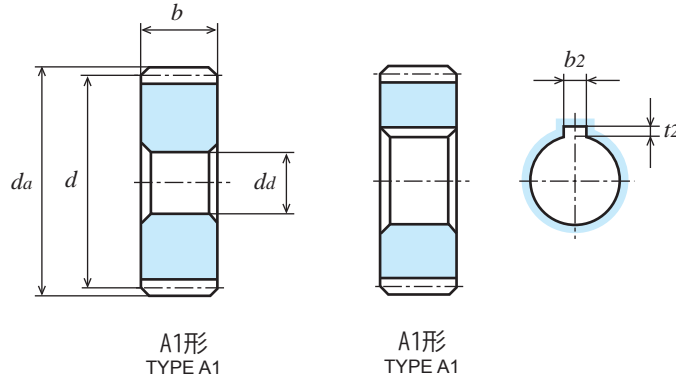

S45C 機械構造用炭素鋼 (JIS G 4051) Material: Carbon Steel (ISO C45)

単位: mm
Dimensions: mm

商品記号 Catalogue Number	歯数 Number of Teeth z	基準円直径 Reference Diameter d	歯先円直径 Outside Diameter da	形 Type	歯幅 Face Width b	穴径 Bore Diameter da(H7)	ハブ外径 Hub Diameter dh	ハブ長さ Hub Projection lh	全長 Overall Length l	キミぞ Key Way b2 × t2	ねじ Set Screw		リム内径 Dimension of Rim di	ウェブ厚さ Thickness of Web bw	重量 Weight W(kg)
											M	ls			
S3S 30A - 2220F	30	φ90	φ96	A1	22	φ20	-	-	22	-	-	-	-	1.04	
S3S 30A = 2225	30	φ90	φ96	A1	22	φ25	-	-	22	8 × 3.3	-	-	-	1.01	
S3S 30A - 3022F	30	φ90	φ96	A1	30	φ22	-	-	30	-	-	-	-	1.41	
S3S 30A = 3030	30	φ90	φ96	A1	30	φ30	-	-	30	8 × 3.3	-	-	-	1.33	
S3S 30A - 3522F	30	φ90	φ96	A1	35	φ22	-	-	35	-	-	-	-	1.64	
S3S 30A = 3525	30	φ90	φ96	A1	35	φ25	-	-	35	8 × 3.3	-	-	-	1.61	
S3S 30A = 3530	30	φ90	φ96	A1	35	φ30	-	-	35	8 × 3.3	-	-	-	1.55	
S3S 30B - 2218	30	φ90	φ96	B1	22	φ18	φ50	13	35	-	-	-	-	1.23	
S3S 30B # 2225	30	φ90	φ96	B1	22	φ25	φ50	13	35	8 × 3.3	M6	6.5	-	1.16	
● S3S 30BF - 3012	30	φ90	φ96	B1	30	φ12(H8)	φ75	20	50	-	-	-	-	2.13	
● S3S 30B - 3012H	30	φ90	φ96	B1	30	φ12(H※)	φ75	20	50	-	-	-	-	2.13	
S3S 30B - 3022N	30	φ90	φ96	B1	30	φ22	φ60	13	43	-	-	-	-	1.66	
S3S 30B - 3520	30	φ90	φ96	B1	35	φ20	φ60	13	48	-	-	-	-	1.92	
S3S 30B # 3525	30	φ90	φ96	B1	35	φ25	φ60	13	48	8 × 3.3	M6	6.5	-	1.84	
S3S 30B # 3530	30	φ90	φ96	B1	35	φ30	φ60	13	48	8 × 3.3	M6	6.5	-	1.76	

●の商品は新商品です。Products with ● marks are new item.

【=】(イコール)にはキー材が付いております。【=】: Gear with key way / with key

【#】(シャープ)にはキー材とセットスクリューが付いております。【#】: Gear with key way and threaded hole / with key and screw.

カタログ記号の末尾に【H】を付した商品は歯部高周波焼入済です。Gear tooth surface completed with induction hardening, Hardness HRC47 to 53.

※ 歯部高周波焼入後の穴修正は行っていません。Bore correcting after induction hardening is not completed.

追加加工の際は、追加加工時の注意をご参照ください。Please refer to Precaution for additional process when additional process.

許容伝達動力表 曲げ強さ (kW)

Allowable transfer capability table (W) Bending Strength

歯数 z	歯幅 b	焼入 H	回転速度 (min ⁻¹) revolution/min						
			10	100	200	400	800	1,200	1,500
30	22	-	0.27	2.73	5.46	9.65	16.33	23.05	27.89
30	30	-	0.370	3.730	7.460	13.170	22.290	31.470	38.070
30	30	○	0.395	3.953	7.906	14.109	24.182	34.786	43.482
30	35	-	0.43	4.35	8.69	15.35	25.97	36.68	44.38

The above references are JGMA standard.

動力の換算式は P26 をご参照ください。Please refer to the conversion formulas of power on page P26.

許容伝達動力表 歯面強さ (kW)

Allowable transfer capability table (kW) Surface Durability

回転速度 (min ⁻¹) revolution/min						
10	100	200	400	800	1,200	1,500
-	-	-	-	-	-	-
0.023	0.230	0.470	0.840	1.500	2.230	2.790
0.102	1.125	2.320	4.269	7.542	11.043	13.940
-	-	-	-	-	-	-

平歯車 SPUR GEARS

モジュール
MODULE

3

圧力角 20° (並歯) 歯数 32
20° PRESSURE ANGLE FULL DEPTH TOOTH Z32

JIS B 1702-1 (ISO) 8級
System of accuracy : JIS B 1702-1(ISO) class 8



御注文には必ず“フルネームで商品記号”を明記してください。
Please refer to the catalogue reference while ordering.

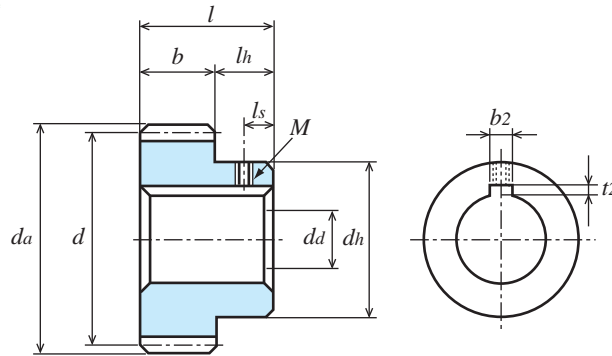

B1形
TYPE B1

S45C 機械構造用炭素鋼 (JIS G 4051) Material : Carbon Steel (ISO C45)

単位 : mm
Dimensions : mm

商品記号 Catalogue Number	歯数 Number of Teeth z	基準円直径 Reference Diameter d	歯先円直径 Outside Diameter da	形 Type	歯幅 Face Width b	穴径 Bore Diameter da(H7)	ハブ外径 Hub Diameter dh	ハブ長さ Hub Projection lh	全長 Overall Length l	キーマゾ Key Way b2 × t2	ねじ Set Screw		リム内径 Dimension of Rim di	ウェブ厚さ Thickness of Web bw	重量 Weight W(kg)
											M	ls			
S3S 32A - 2020F	32	φ96	φ102	A1	20	φ20	-	-	20	-	-	-	-	1.09	
S3S 32A = 2025	32	φ96	φ102	A1	20	φ25	-	-	20	8 × 3.3	-	-	-	1.06	
S3S 32A - 3022F	32	φ96	φ102	A1	30	φ22	-	-	30	-	-	-	-	1.62	
S3S 32A = 3030	32	φ96	φ102	A1	30	φ30	-	-	30	8 × 3.3	-	-	-	1.53	
S3S 32A - 3222F	32	φ96	φ102	A1	32	φ22	-	-	32	-	-	-	-	1.72	
S3S 32A = 3225	32	φ96	φ102	A1	32	φ25	-	-	32	8 × 3.3	-	-	-	1.69	
S3S 32A = 3230	32	φ96	φ102	A1	32	φ30	-	-	32	8 × 3.3	-	-	-	1.63	
S3S 32B - 2018	32	φ96	φ102	B1	20	φ18	φ50	13	33	-	-	-	-	1.27	
S3S 32B # 2025	32	φ96	φ102	B1	20	φ25	φ50	13	33	8 × 3.3	M6	6.5	-	1.20	
S3S 32B - 3025N	32	φ96	φ102	B1	30	φ25	φ65	13	43	-	-	-	-	1.88	
S3S 32B # 3030	32	φ96	φ102	B1	30	φ30	φ65	13	43	8 × 3.3	M6	6.5	-	1.74	
S3S 32B - 3220	32	φ96	φ102	B1	32	φ20	φ60	13	45	-	-	-	-	2.00	
S3S 32B # 3225	32	φ96	φ102	B1	32	φ25	φ60	13	45	8 × 3.3	M6	6.5	-	1.92	
S3S 32B # 3230	32	φ96	φ102	B1	32	φ30	φ60	13	45	8 × 3.3	M6	6.5	-	1.85	

【=】 (イコール) にはキー材が付いております。【=】: Gear with key way / with key

【#】 (シャープ) にはキー材とセットスクリューが付いております。【#】: Gear with key way and threaded hole / with key and screw.

許容伝達動力表 曲げ強さ (kW)

T (N · m)

Allowable transfer capability table (W) Bending Strength

歯数 z	歯幅 b	回転速度 (min ⁻¹) revolution/min							回転速度 (min ⁻¹) revolution/min
		10	100	200	400	800	1,200	1,500	
32	20	0.27	2.71	5.41	9.41	16.03	22.65	27.36	100
32	30	0.41	4.06	8.12	14.11	24.05	33.98	41.04	258.79
32	32	0.43	4.33	8.66	15.05	25.66	36.25	43.78	387.71
									413.50

KG 規格は“並幅” (軽荷重用) と“広幅” (重荷重用) があります。ご用途に応じてお選び下さい。

KG STOCK GEARS has Wide-face width for Heavy load, and Standard-face width for Light load.

You are able to multiple choices for your suitable design from our wide range.

The above numerical values are equivalent to JGMA formulas as reference only.

動力の換算式は P26 をご参照ください。Please refer to the conversion fomulas of power on page P26.

目次
CONTENTS

インフォメーション
INFORMATION

ギヤボックス
GEAR BOXES

ノーバッキングスピギヤ
ANTI BACKLASH SPUR GEARS

歯研平歯車
GROUND SPUR GEARS

平歯車
SPUR GEARS

内歯車
INTERNAL GEARS

歯研ラック
GROUND RACKS

ラック
RACKS

ひかりスピギヤ
HELICAL GEARS AND SCREW GEARS

ワーム
WORMS AND WORM WHEELS

かさ歯車
BEVEL GEARS

スプロケット
SPROCKETS

技術資料
REFERENCE DATA

平歯車 SPUR GEARS

モジュール
MODULE

3

圧力角 20° (並歯) 歯数 36
20° PRESSURE ANGLE FULL DEPTH TOOTH Z36

JIS B 1702-1 (ISO) 8級
System of accuracy: JIS B 1702-1(ISO) class 8



New 仕様変更 省スペース・軽量化、締結加工不要。
Specification change Space-saving and weight saving.
Additional machining on tightening is not necessary.

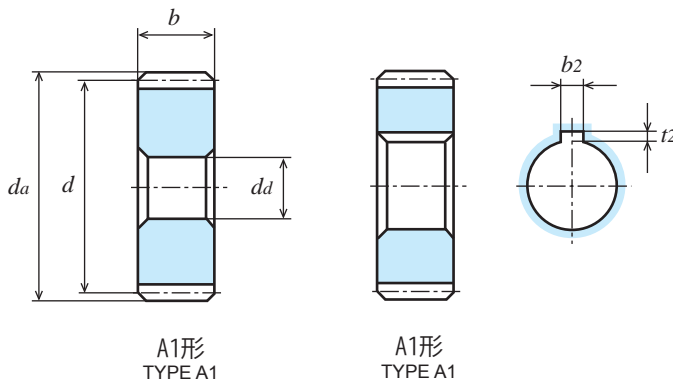

S45C 機械構造用炭素鋼 (JIS G 4051) Material: Carbon Steel (ISO C45)

単位: mm
Dimensions: mm

商品記号 Catalogue Number	歯数 Number of Teeth <i>z</i>	基準円直径 Reference Diameter <i>d</i>	歯先円直径 Outside Diameter <i>da</i>	形 Type	歯幅 Face Width <i>b</i>	穴径 Bore Diameter <i>da</i> (H7)	ハブ外径 Hub Diameter <i>dh</i>	ハブ長さ Hub Projection <i>lh</i>	全長 Overall Length <i>l</i>	キミぞ Key Way <i>b2 × t2</i>	ねじ Set Screw		リム内径 Dimension of Rim <i>di</i>	ウェブ厚さ Thickness of Web <i>bw</i>	重量 Weight <i>W</i> (kg)
											<i>M</i>	<i>ls</i>			
S3S 36A - 2020F	36	φ108	φ114	A1	20	φ20	-	-	20	-	-	-	-	-	1.39
S3S 36A = 2025	36	φ108	φ114	A1	20	φ25	-	-	20	8 × 3.3	-	-	-	-	1.36
S3S 36A = 3030	36	φ108	φ114	A1	30	φ30	-	-	30	8 × 3.3	-	-	-	-	1.99
S3S 36A - 3222F	36	φ108	φ114	A1	32	φ22	-	-	32	-	-	-	-	-	2.21
S3S 36A = 3225	36	φ108	φ114	A1	32	φ25	-	-	32	8 × 3.3	-	-	-	-	2.17
S3S 36A = 3230	36	φ108	φ114	A1	32	φ30	-	-	32	8 × 3.3	-	-	-	-	2.12
S3S 36B - 2020	36	φ108	φ114	B1	20	φ20	φ50	13	33	-	-	-	-	-	1.56
S3S 36B # 2025	36	φ108	φ114	B1	20	φ25	φ50	13	33	8 × 3.3	M6	6.5	-	-	1.50
S3S 36B - 3025N	36	φ108	φ114	B1	30	φ25	φ70	13	43	-	-	-	-	-	2.39
S3S 36B # 3035	36	φ108	φ114	B1	30	φ35	φ70	13	43	10 × 3.3	M8	6.5	-	-	2.21
S3S 36B - 3222	36	φ108	φ114	B1	32	φ22	φ60	13	45	-	-	-	-	-	2.46
S3S 36B # 3225	36	φ108	φ114	B1	32	φ25	φ60	13	45	8 × 3.3	M6	6.5	-	-	2.41
S3S 36B # 3230	36	φ108	φ114	B1	32	φ30	φ60	13	45	8 × 3.3	M6	6.5	-	-	2.33

【=】(イコール)にはキー材が付いております。【=】: Gear with key way / with key

【#】(シャープ)にはキー材とセットスクリューが付いております。【#】: Gear with key way and threaded hole / with key and screw.

許容伝達動力表 曲げ強さ (kW)

Allowable transfer capability table (W) Bending Strength

歯数 <i>z</i>	歯幅 <i>b</i>	回転速度 (min ⁻¹) revolution/min							回転速度 (min ⁻¹) revolution/min
		10	100	200	400	800	1,200	1,500	
36	20	0.32	3.16	6.20	10.64	18.39	26.00	31.63	100
36	30	0.47	4.74	9.31	15.96	27.58	39.00	47.44	301.77
36	32	0.51	5.06	9.93	17.02	29.42	41.60	50.60	452.65
									483.21

The above numerical values are equivalent to JGMA formulas as reference only.

動力の換算式は P26 をご参照ください。Please refer to the conversion fomulas of power on page P26.

平歯車

SPUR GEARS

モジュール
MODULE

3

圧力角 20° (並歯) 歯数 40 45
20° PRESSURE ANGLE FULL DEPTH TOOTH Z 40 to Z 45

JIS B 1702-1 (ISO) 8級 (高周波焼入品: 9級)
System of accuracy: JIS B 1702-1(ISO) class 8
(Induction hardened products: class 9)



御注文には必ず“フルネームで商品記号”を明記してください。
Please refer to the catalogue reference while ordering.

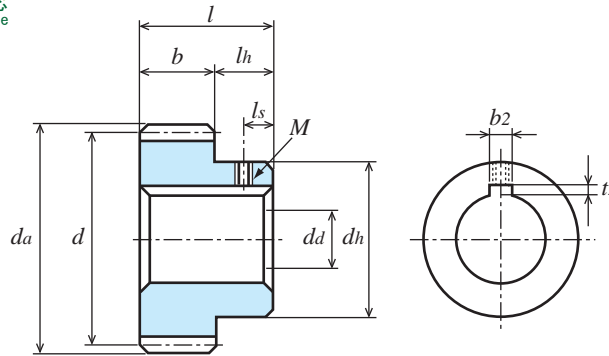

B1形
TYPE B1

S45C 機械構造用炭素鋼 (JIS G 4051) Material: Carbon Steel (ISO C45)

単位: mm
Dimensions: mm

商品記号 Catalogue Number	歯数 Number of Teeth z	基準円直径 Reference Diameter d	歯先円直径 Outside Diameter da	形 Type	歯幅 Face Width b	穴径 Bore Diameter da(H7)	ハブ外径 Hub Diameter dh	ハブ長さ Hub Projection lh	全長 Overall Length l	キミぞ Key Way b2 × t2	ねじ Set Screw		リム内径 Dimension of Rim di	ウェブ厚さ Thickness of Web bw	重量 Weight W(kg)
											M	ls			
S3S 40A - 2020F	40	φ120	φ126	A1	20	φ20	-	-	20	-	-	-	-	-	1.73
S3S 40A = 2025	40	φ120	φ126	A1	20	φ25	-	-	20	8 × 3.3	-	-	-	-	1.69
S3S 40A = 3030	40	φ120	φ126	A1	30	φ30	-	-	30	8 × 3.3	-	-	-	-	2.49
S3S 40A - 3222F	40	φ120	φ126	A1	32	φ22	-	-	32	-	-	-	-	-	2.75
S3S 40A = 3225	40	φ120	φ126	A1	32	φ25	-	-	32	8 × 3.3	-	-	-	-	2.71
S3S 40A = 3230	40	φ120	φ126	A1	32	φ30	-	-	32	8 × 3.3	-	-	-	-	2.66
S3S 40B - 2020	40	φ120	φ126	B1	20	φ20	φ50	13	33	-	-	-	-	-	1.90
S3S 40B # 2025	40	φ120	φ126	B1	20	φ25	φ50	13	33	8 × 3.3	M6	6.5	-	-	1.84
● S3S 40BF - 3015	40	φ120	φ126	B1	30	φ15(H8)	φ85	20	50	-	-	-	-	-	3.47
● S3S 40B - 3015H	40	φ120	φ126	B1	30	φ15(H※)	φ85	20	50	-	-	-	-	-	3.47
S3S 40B - 3025N	40	φ120	φ126	B1	30	φ25	φ70	13	43	-	-	-	-	-	2.89
S3S 40B # 3035	40	φ120	φ126	B1	30	φ35	φ70	13	43	10 × 3.3	M8	6.5	-	-	2.72
S3S 40B - 3222	40	φ120	φ126	B1	32	φ22	φ60	13	45	-	-	-	-	-	3.00
S3S 40B # 3225	40	φ120	φ126	B1	32	φ25	φ60	13	45	8 × 3.3	M6	6.5	-	-	2.95
S3S 40B # 3230	40	φ120	φ126	B1	32	φ30	φ60	13	45	8 × 3.3	M6	6.5	-	-	2.87
S3S 45B - 2020	45	φ135	φ141	B1	20	φ20	φ70	13	33	-	-	-	-	-	2.56
S3S 45B - 3222F	45	φ135	φ141	B1	32	φ22	φ70	13	45	-	-	-	-	-	3.85

●の商品は新商品です。Products with ● marks are new item.

【=】(イコール)にはキー材が付いております。 [=]: Gear with key way / with key

【#】(シャープ)にはキー材とセットスクリューが付いております。 [#]: Gear with key way and threaded hole / with key and screw.

カタログ記号の末尾に【H】を付した商品は歯部高周波焼入済です。Gear tooth surface completed with induction hardening, Hardness HRC47 to 53.

※
歯部高周波焼入後の穴修正は行っていません。Bore correcting after induction hardening is not completed.

追加加工の際は、追加加工時の注意をご参照ください。Please refer to Precaution for additional process when additional process.

許容伝達動力表 曲げ強さ (kW)

Allowable transfer capability table (W) Bending Strength

歯数 z	歯幅 b	焼入 H	回転速度 (min ⁻¹) revolution/min						
			10	100	200	400	800	1,200	1,500
40	20	-	0.36	3.62	6.98	11.81	20.69	29.29	36.23
40	30	-	0.540	5.420	10.440	17.680	30.970	43.830	54.230
40	30	○	0.575	5.749	11.110	19.063	33.729	50.593	63.241
40	32	-	0.58	5.80	11.16	18.90	33.11	46.86	57.97
45	20	-	0.42	4.20	7.91	13.19	23.65	33.62	-
45	32	-	0.67	6.72	12.66	21.11	37.83	53.79	-

The above references are JGMA standard.

動力の換算式は P26 をご参照ください。Please refer to the conversion formulas of power on page P26.

許容伝達動力表 歯面強さ (kW)

Allowable transfer capability table (kW) Surface Durability

回転速度 (min ⁻¹) revolution/min						
10	100	200	400	800	1,200	1,500
-	-	-	-	-	-	-
0.042	0.430	0.830	1.450	2.720	4.090	5.220
0.186	2.056	4.096	7.245	13.214	20.177	25.469
-	-	-	-	-	-	-
-	-	-	-	-	-	-
-	-	-	-	-	-	-

目次
CONTENTS

インフォメーション
INFORMATION

ギヤボックス
GEAR BOXES

ノーバッキングギヤ
ANTI BACKLASH SPUR GEARS

歯研平歯車
GROUND SPUR GEARS

歯研平歯車
SPUR GEARS

内歯車
INTERNAL GEARS

歯研ラック
GROUND RACKS

ラック
RACKS

ハニカムギヤ
HEXAGONAL GEAR AND SCREW GEARS

ワーム
WORMS AND WORM WHEELS

かさ歯車
BEVEL GEARS

スプロケット
SPROCKETS

技術データ
REFERENCE DATA

平歯車 SPUR GEARS

モジュール
MODULE

3

圧力角 20° (並歯) 歯数 48
20° PRESSURE ANGLE FULL DEPTH TOOTH Z 48

JIS B 1702-1 (ISO) 8 級
System of accuracy : JIS B 1702-1(ISO) class 8



New 仕様変更 省スペース・軽量化、締結加工不要。
Specification change Space-saving and weight saving.
Additional machining on tightening is not necessary.

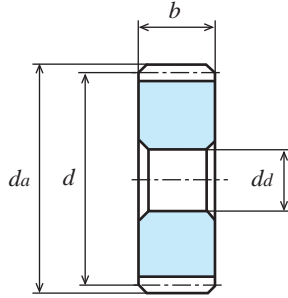

A1形
TYPE A1

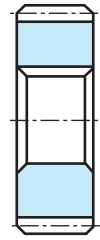

A1形
TYPE A1

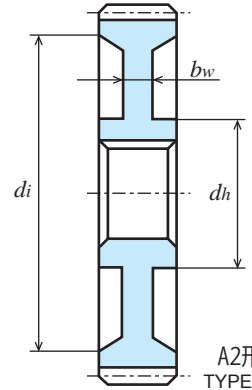
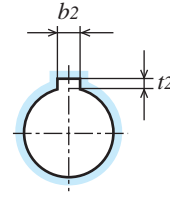

A2形
TYPE A2

S45C 機械構造用炭素鋼 (JIS G 4051) Material : Carbon Steel (ISO C45)

単位 : mm
Dimensions : mm

商品記号 Catalogue Number	歯数 Number of Teeth z	基準円直径 Reference Diameter d	歯先円直径 Outside Diameter da	形 Type	歯幅 Face Width b	穴径 Bore Diameter da(H7)	ハブ外径 Hub Diameter dh	ハブ長さ Hub Projection lh	全長 Overall Length l	キミぞ Key Way b2 × t2	ねじ Set Screw		リム内径 Dimension of Rim di	ウェブ厚さ Thickness of Web bw	重量 Weight W(kg)
											M	ls			
S3S 48A - 2020F	48	φ144	φ150	A1	20	φ20	-	-	20	-	-	-	-	2.51	
S3S 48A = 2025	48	φ144	φ150	A2	20	φ25	φ50	-	20	8 × 3.3	-	φ116	10	1.84	
S3S 48A = 3030	48	φ144	φ150	A2	30	φ30	φ60	-	30	8 × 3.3	-	φ116	16	2.89	
S3S 48A - 3222F	48	φ144	φ150	A1	32	φ22	-	-	32	-	-	-	-	4.00	
S3S 48A = 3230	48	φ144	φ150	A2	32	φ30	φ60	-	32	8 × 3.3	-	φ116	16	3.04	
S3S 48B - 2020	48	φ144	φ150	B1	20	φ20	φ50	13	33	-	-	-	-	2.68	
S3S 48B # 2025	48	φ144	φ150	B3	20	φ25	φ50	13	33	8 × 3.3	M6	6.5	φ116	10	1.99
S3S 48B - 3025N	48	φ144	φ150	B1	30	φ25	φ80	13	43	-	-	-	-	4.19	
S3S 48B # 3040	48	φ144	φ150	B3	30	φ40	φ80	13	43	12 × 3.3	M8	6.5	φ116	16	3.38
S3S 48B - 3222	48	φ144	φ150	B1	32	φ22	φ60	13	45	-	-	-	-	4.25	
S3S 48B # 3230	48	φ144	φ150	B3	32	φ30	φ60	13	45	8 × 3.3	M6	6.5	φ116	16	3.25

【=】 (イコール) にはキー材が付いております。 [=] : Gear with key way / with key

【#】 (シャープ) にはキー材とセットスクリューが付いております。 [#] : Gear with key way and threaded hole / with key and screw.

許容伝達動力表 曲げ強さ (kW)

T (N · m)

Allowable transfer capability table (W) Bending Strength

歯数 z	歯幅 b	回転速度 (min ⁻¹) revolution/min							回転速度 (min ⁻¹) revolution/min
		10	100	200	400	800	1,200	1,500	
48	20	0.46	4.55	8.46	14.00	25.40	36.43	-	100
48	30	0.68	6.83	12.69	21.01	38.10	54.65	-	100
48	32	0.73	7.29	13.54	22.41	40.64	58.29	-	100

The above numerical values are equivalent to JGMA formulas as reference only.

動力の換算式は P26 をご参照ください。 Please refer to the conversion fomulas of power on page P26.

平歯車

SPUR GEARS

モジュール
MODULE

3

圧力角 20° (並歯) 歯数 50

20° PRESSURE ANGLE FULL DEPTH TOOTH Z 50

JIS B 1702-1 (ISO) 8級 (高周波焼入品: 9級)
System of accuracy: JIS B 1702-1(ISO) class 8
(Induction hardened products: class 9)



御注文には必ず“フルネームで商品記号”を明記してください。

Please refer to the catalogue reference while ordering.

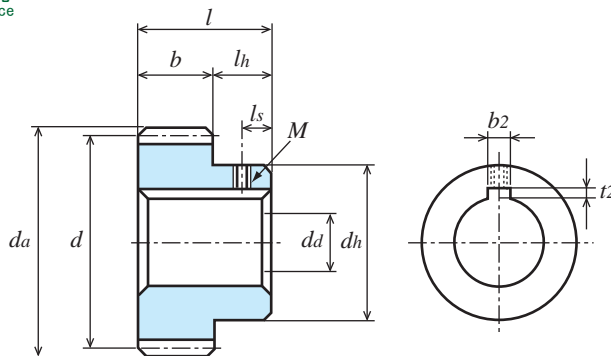

B1形
TYPE B1

S45C 機械構造用炭素鋼 (JIS G 4051)

Material: Carbon Steel (ISO C45)

単位: mm
Dimensions: mm

商品記号 Catalogue Number	歯数 Number of Teeth z	基準円直径 Reference Diameter d	歯先円直径 Outside Diameter da	形 Type	歯幅 Face Width b	穴径 Bore Diameter da(H7)	ハブ外径 Hub Diameter dh	ハブ長さ Hub Projection lh	全長 Overall Length l	キミぞ Key Way b2 × t2	ねじ Set Screw		リム内径 Dimension of Rim di	ウエブ厚さ Thickness of Web bw	重量 Weight W(kg)
											M	ls			
S3S 50A - 2020F	50	φ150	φ156	A1	20	φ20	-	-	20	-	-	-	-	2.73	
S3S 50A = 2025	50	φ150	φ156	A2	20	φ25	φ 50	-	20	8 × 3.3	-	φ122	10	1.97	
S3S 50A = 2030	50	φ150	φ156	A2	20	φ30	φ 60	-	20	8 × 3.3	-	φ122	10	1.94	
S3S 50A = 3030	50	φ150	φ156	A2	30	φ30	φ 60	-	30	8 × 3.3	-	φ122	16	3.10	
S3S 50A - 3222F	50	φ150	φ156	A1	32	φ22	-	-	32	-	-	-	-	4.34	
S3S 50A = 3230	50	φ150	φ156	A2	32	φ30	φ 60	-	32	8 × 3.3	-	φ122	16	3.25	
S3S 50A = 3235	50	φ150	φ156	A2	32	φ35	φ 70	-	32	10 × 3.3	-	φ122	16	3.31	
S3S 50B - 2020	50	φ150	φ156	B1	20	φ20	φ 60	13	33	-	-	-	-	2.98	
S3S 50B # 2025	50	φ150	φ156	B3	20	φ25	φ 60	13	33	8 × 3.3	M6	6.5	φ122	10	2.27
S3S 50B # 2030	50	φ150	φ156	B3	20	φ30	φ 60	13	33	8 × 3.3	M6	6.5	φ122	10	2.22
● S3S 50BF - 3015	50	φ150	φ156	B1	30	φ15(H8)	φ105	20	50	-	-	-	-	5.43	
● S3S 50B - 3015H	50	φ150	φ156	B1	30	φ15(H※)	φ105	20	50	-	-	-	-	5.43	
S3S 50B - 3025N	50	φ150	φ156	B1	30	φ25	φ 80	13	43	-	-	-	-	4.51	
S3S 50B # 3040	50	φ150	φ156	B3	30	φ40	φ 80	13	43	12 × 3.3	M8	6.5	φ122	16	3.58
S3S 50B - 3222	50	φ150	φ156	B1	32	φ22	φ 70	13	45	-	-	-	-	4.70	
S3S 50B # 3230	50	φ150	φ156	B3	32	φ30	φ 70	13	45	8 × 3.3	M6	6.5	φ122	16	3.69
S3S 50B # 3235	50	φ150	φ156	B3	32	φ35	φ 70	13	45	10 × 3.3	M8	6.5	φ122	16	3.60

●の商品は新商品です。Products with ● marks are new item.

【=】(イコール)にはキー材が付いております。 [=]: Gear with key way / with key

【#】(シャープ)にはキー材とセットスクリューが付いております。 [#]: Gear with key way and threaded hole / with key and screw.

カタログ記号の末尾に【H】を付した商品は歯部高周波焼入済です。 Gear tooth surface completed with induction hardening, Hardness HRC47 to 53.

※
歯部高周波焼入後の穴修正は行っていません。 Bore correcting after induction hardening is not completed.

追加加工の際は、追加加工時の注意をご参照ください。 Please refer to Precaution for additional process when additional process.

許容伝達動力表 曲げ強さ (kW)

Allowable transfer capability table (W) Bending Strength

歯数 z	歯幅 b	焼入 H	回転速度 (min ⁻¹) revolution/min						
			10	100	200	400	800	1,200	1,500
50	20	-	0.48	4.79	8.82	14.66	26.56	38.31	-
50	30	-	0.720	7.150	13.180	21.890	39.670	57.230	-
50	30	○	0.7585	7.5845	14.074	23.717	44.496	66.74	-
50	32	-	0.77	7.66	14.12	23.45	42.49	61.30	-

The above references are JGMA standard.

動力の換算式は P26 をご参照ください。 Please refer to the conversion formulas of power on page P26.

許容伝達動力表 歯面強さ (kW)

Allowable transfer capability table (kW) Surface Durability

回転速度 (min ⁻¹) revolution/min						
10	100	200	400	800	1,200	1,500
-	-	-	-	-	-	-
0.067	0.680	1.280	2.220	4.360	6.680	-
0.2967	3.2818	6.2774	10.905	21.09	32.203	-
-	-	-	-	-	-	-

目次 CONTENTS

インフォメーション INFORMATION

ギヤボックス GEAR BOXES

ノーバッキングバックラッシュギヤ ANTI BACKLASH SPUR GEARS

歯研平歯車 GROUND SPUR GEARS

歯研平歯車 SPUR GEARS

内歯車 INTERNAL GEARS

歯研ラック GROUND RACKS

ラック RACKS

ハブ・スプロケットギヤ HUB GEARS AND SPROCKET GEARS

ワーム・ワームホイール WORMS AND WORM WHEELS

かさ歯車 BEVEL GEARS

スプロケット SPROCKETS

技術資料 REFERENCE DATA

平歯車 SPUR GEARS

モジュール
MODULE

3

圧力角 20° (並歯) 歯数 56

20° PRESSURE ANGLE FULL DEPTH TOOTH Z 56

JIS B 1702-1 (ISO) 8 級
System of accuracy : JIS B 1702-1(ISO) class 8



New 仕様変更 省スペース・軽量化、締結加工不要。
Specification change Space-saving and weight saving.
Additional machining on tightening is not necessary.

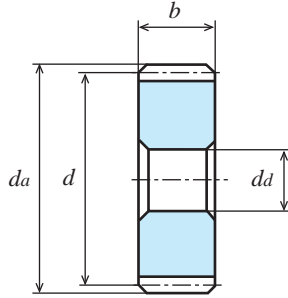

A1形
TYPE A1

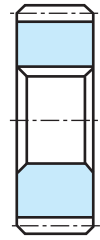

A1形
TYPE A1

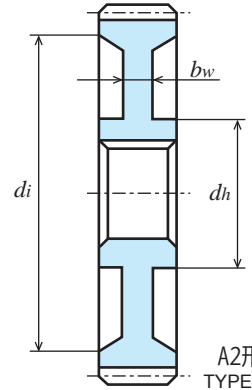
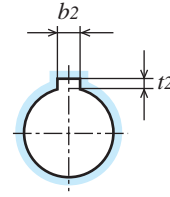

A2形
TYPE A2

S45C 機械構造用炭素鋼 (JIS G 4051)
Material : Carbon Steel (ISO C45)

単位 : mm
Dimensions : mm

商品記号 Catalogue Number	歯数 Number of Teeth <i>z</i>	基準円直径 Reference Diameter <i>d</i>	歯先円直径 Outside Diameter <i>da</i>	形 Type	歯幅 Face Width <i>b</i>	穴径 Bore Diameter <i>da(H7)</i>	ハブ外径 Hub Diameter <i>dh</i>	ハブ長さ Hub Projection <i>lh</i>	全長 Overall Length <i>l</i>	キミぞ Key Way <i>b2 × t2</i>	ねじ Set Screw		リム内径 Dimension of Rim <i>di</i>	ウェブ厚さ Thickness of Web <i>bw</i>	重量 Weight <i>W(kg)</i>
											<i>M</i>	<i>ls</i>			
S3S 56A – 2020F	56	φ168	φ174	A1	20	φ20	-	-	20	-	-	-	-	-	3.43
S3S 56A = 2025	56	φ168	φ174	A2	20	φ25	φ50	-	20	8 × 3.3	-	-	φ140	10	2.39
S3S 56A – 3222F	56	φ168	φ174	A1	32	φ22	-	-	32	-	-	-	-	-	5.47
S3S 56A = 3230	56	φ168	φ174	A2	32	φ30	φ60	-	32	8 × 3.3	-	-	φ140	16	3.93
S3S 56B – 2020	56	φ168	φ174	B1	20	φ20	φ60	13	33	-	-	-	-	-	3.69
S3S 56B # 2025	56	φ168	φ174	B3	20	φ25	φ60	13	33	8 × 3.3	M6	6.5	φ140	10	2.70
S3S 56B – 3222	56	φ168	φ174	B1	32	φ22	φ70	13	45	-	-	-	-	-	5.83
S3S 56B # 3230	56	φ168	φ174	B3	32	φ30	φ70	13	45	8 × 3.3	M6	6.5	φ140	16	4.38
S3S 56B # 3235	56	φ168	φ174	B3	32	φ35	φ70	13	45	10 × 3.3	M8	6.5	φ140	16	4.28

【=】 (イコール) にはキー材が付いております。【=】: Gear with key way / with key

【#】 (シャープ) にはキー材とセットスクリューが付いております。【#】: Gear with key way and threaded hole / with key and screw.

許容伝達動力表 曲げ強さ (kW)

T (N · m)

Allowable transfer capability table (W) Bending Strength

歯数 <i>z</i>	歯幅 <i>b</i>	回転速度 (min ⁻¹) revolution/min							回転速度 (min ⁻¹) revolution/min
		10	100	200	400	800	1,200	1,500	
56	20	0.55	5.50	9.87	16.59	29.97	-	-	100
56	32	0.88	8.80	15.80	26.54	47.95	-	-	840.37

The above numerical values are equivalent to JGMA formulas as reference only.

動力の換算式は P26 をご参照ください。Please refer to the conversion fomulas of power on page P26.

平歯車

SPUR GEARS

モジュール
MODULE

3

圧力角 20° (並歯) 歯数 60

20° PRESSURE ANGLE FULL DEPTH TOOTH Z 60

JIS B 1702-1 (ISO) 8級 (高周波焼入品: 9級)
System of accuracy: JIS B 1702-1(ISO) class 8
(Induction hardened products: class 9)



御注文には必ず“フルネームで商品記号”を明記してください。

Please refer to the catalogue reference while ordering.

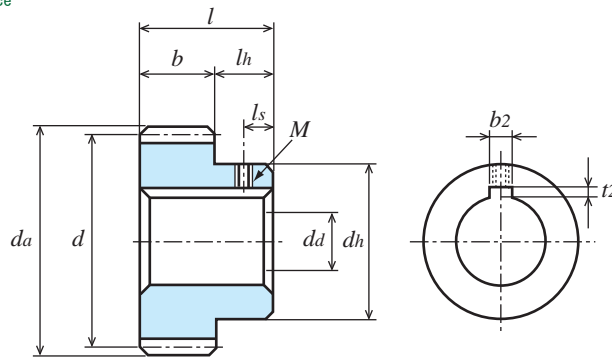

B1形
TYPE B1

S45C 機械構造用炭素鋼 (JIS G 4051)

Material: Carbon Steel (ISO C45)

単位: mm
Dimensions: mm

商品記号 Catalogue Number	歯数 Number of Teeth z	基準円直径 Reference Diameter d	歯先円直径 Outside Diameter da	形 Type	歯幅 Face Width b	穴径 Bore Diameter da(H7)	ハブ外径 Hub Diameter dh	ハブ長さ Hub Projection lh	全長 Overall Length l	キミぞ Key Way b2 × t2	ねじ Set Screw		リム内径 Dimension of Rim di	ウェブ厚さ Thickness of Web bw	重量 Weight W(kg)
											M	ls			
S3S 60A - 2020F	60	φ180	φ186	A1	20	φ20	-	-	20	-	-	-	-	3.95	
S3S 60A = 2030	60	φ180	φ186	A2	20	φ30	φ60	-	20	8 × 3.3	-	-	φ152	10	2.73
S3S 60A = 3030	60	φ180	φ186	A2	30	φ30	φ60	-	30	8 × 3.3	-	-	φ152	16	4.24
S3S 60A - 3222F	60	φ180	φ186	A1	32	φ22	-	-	32	-	-	-	-	6.30	
S3S 60A = 3230	60	φ180	φ186	A2	32	φ30	φ60	-	32	8 × 3.3	-	-	φ152	16	4.42
S3S 60A = 3235	60	φ180	φ186	A2	32	φ35	φ70	-	32	10 × 3.3	-	-	φ152	16	4.48
S3S 60B - 2022	60	φ180	φ186	B1	20	φ22	φ60	13	33	-	-	-	-	4.19	
S3S 60B # 2030	60	φ180	φ186	B3	20	φ30	φ60	13	33	8 × 3.3	M6	6.5	φ152	10	2.94
● S3S 60BF - 3015	60	φ180	φ186	B1	30	φ15(H8)	φ130	20	50	-	-	-	-	7.98	
● S3S 60B - 3015H	60	φ180	φ186	B1	30	φ15(H※)	φ130	20	50	-	-	-	-	7.98	
S3S 60B - 3025N	60	φ180	φ186	B1	30	φ25	φ80	13	43	-	-	-	-	6.34	
S3S 60B # 3040	60	φ180	φ186	B3	30	φ40	φ80	13	43	12 × 3.3	M8	6.5	φ152	16	4.73
S3S 60B - 3225	60	φ180	φ186	B1	32	φ25	φ70	13	45	-	-	-	-	6.62	
S3S 60B # 3230	60	φ180	φ186	B3	32	φ30	φ70	13	45	8 × 3.3	M6	6.5	φ152	16	4.87
S3S 60B # 3235	60	φ180	φ186	B3	32	φ35	φ70	13	45	10 × 3.3	M8	6.5	φ152	16	4.77

●の商品は新商品です。Products with ● marks are new item.

【=】(イコール)にはキー材が付いております。【=】: Gear with key way / with key

【#】(シャープ)にはキー材とセットスクリューが付いております。【#】: Gear with key way and threaded hole / with key and screw.

カタログ記号の末尾に【H】を付した商品は歯部高周波焼入済です。Gear tooth surface completed with induction hardening, Hardness HRC47 to 53.

※ 歯部高周波焼入後の穴修正は行っていません。Bore correcting after induction hardening is not completed.

追加加工の際は、追加加工時の注意をご参照ください。Please refer to Precaution for additional process when additional process.

許容伝達動力表 曲げ強さ (kW)

Allowable transfer capability table (W) Bending Strength

歯数 z	歯幅 b	焼入 H	回転速度 (min ⁻¹) revolution/min						
			10	100	200	400	800	1,200	1,500
60	20	-	0.60	5.98	10.55	17.86	32.20	-	-
60	30	-	0.890	8.910	15.740	26.640	48.030	-	-
60	30	○	0.9451	9.4507	16.866	28.907	55.44	-	-
60	32	-	0.96	9.56	16.88	28.57	51.52	-	-

The above references are JGMA standard.

動力の換算式は P26 をご参照ください。Please refer to the conversion formulas of power on page P26.

許容伝達動力表 歯面強さ (kW)

Allowable transfer capability table (kW) Surface Durability

回転速度 (min ⁻¹) revolution/min						
10	100	200	400	800	1,200	1,500
-	-	-	-	-	-	-
0.099	1.010	1.810	3.230	6.390	-	-
0.4347	4.8084	8.8459	15.63	30.901	-	-
-	-	-	-	-	-	-

目次
CONTENTS

インフォメーション
INFORMATION

ギヤボックス
GEAR BOXES

ノーバッキングギヤ
ANTI BACKLASH SPUR GEARS

歯研歯車
GROUND SPUR GEARS

歯研歯車
SPUR GEARS

内歯車
INTERNAL GEARS

歯研歯車
GROUND RACKS

ラック
RACKS

ハニカムギヤ
HEXAGONAL GEAR AND SCREW GEARS

ウォーム
WORMS AND WORM WHEELS

かさ歯車
BEVEL GEARS

スプロケット
SPROCKETS

技術資料
REFERENCE DATA

平歯車

SPUR GEARS

モジュール
MODULE

3

圧力角 20° (並歯) 歯数 64 ~ 80
20° PRESSURE ANGLE FULL DEPTH TOOTH Z 64 to Z 80

JIS B 1702-1 (ISO) 8級 (高周波焼入品: 9級)
System of accuracy: JIS B 1702-1(ISO) class 8
(Induction hardened products: class 9)



New 仕様変更 省スペース・軽量化、締結加工不要。
Specification change Space-saving and weight saving.
Additional machining on tightening is not necessary.

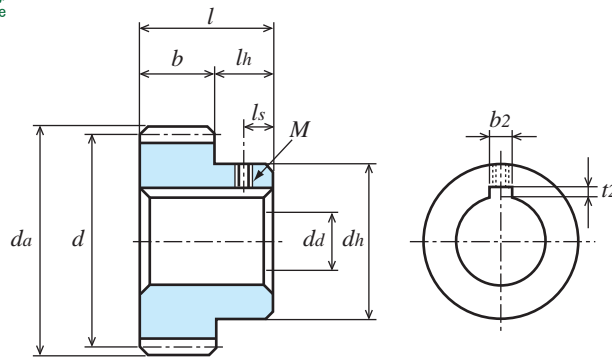

B1形
TYPE B1

S45C 機械構造用炭素鋼 (JIS G 4051) Material: Carbon Steel (ISO C45)

単位: mm
Dimensions: mm

商品記号 Catalogue Number	歯数 Number of Teeth z	基準円直径 Reference Diameter d	歯先円直径 Outside Diameter da	形 Type	歯幅 Face Width b	穴径 Bore Diameter da(H7)	ハブ外径 Hub Diameter dh	ハブ長さ Hub Projection lh	全長 Overall Length l	キミぞ Key Way b2 × t2	ねじ Set Screw		リム内径 Dimension of Rim di	ウエブ厚さ Thickness of Web bw	重量 Weight W(kg)
											M	ls			
S3S 64A - 2022F	64	φ192	φ198	A1	20	φ22	-	-	20	-	-	-	-	4.49	
S3S 64A = 2030	64	φ192	φ198	A2	20	φ30	φ60	-	20	8 × 3.3	-	φ164	10	3.05	
S3S 64A - 3222F	64	φ192	φ198	A1	32	φ22	-	-	32	-	-	-	-	7.18	
S3S 64A = 3230	64	φ192	φ198	A2	32	φ30	φ60	-	32	8 × 3.3	-	φ164	16	4.94	
S3S 64A = 3235	64	φ192	φ198	A2	32	φ35	φ70	-	32	10 × 3.3	-	φ164	16	5.00	
S3S 64B - 2022	64	φ192	φ198	B1	20	φ22	φ60	13	33	-	-	-	-	4.74	
S3S 64B # 2030	64	φ192	φ198	B3	20	φ30	φ60	13	33	8 × 3.3	M6	6.5	φ164	10	3.27
S3S 64B - 3225	64	φ192	φ198	B1	32	φ25	φ70	13	45	-	-	-	-	7.50	
S3S 64B # 3230	64	φ192	φ198	B3	32	φ30	φ70	13	45	8 × 3.3	M6	6.5	φ164	16	5.38
S3S 64B # 3235	64	φ192	φ198	B3	32	φ35	φ70	13	45	10 × 3.3	M8	6.5	φ164	16	5.29
● S3S 70BF - 3020	70	φ210	φ216	B1	30	φ20	φ150	20	50	-	-	-	-	10.78	
● S3S 70B - 3020H	70	φ210	φ216	B1	30	φ20(H※)	φ150	20	50	-	-	-	-	10.78	
● S3S 80BF - 3020	80	φ240	φ246	B1	30	φ20	φ170	20	50	-	-	-	-	14.06	
● S3S 80B - 3020H	80	φ240	φ246	B1	30	φ20(H※)	φ170	20	50	-	-	-	-	14.06	

●の商品は新商品です。Products with ● marks are new item.

【=】(イコール)にはキー材が付いております。【=】: Gear with key way / with key

【#】(シャープ)にはキー材とセットスクリューが付いております。【#】: Gear with key way and threaded hole / with key and screw.

カタログ記号の末尾に【H】を付した商品は歯部高周波焼入済です。Gear tooth surface completed with induction hardening, Hardness HRC47 to 53.

※
歯部高周波焼入後の穴修正は行っていません。Bore correcting after induction hardening is not completed.

追加加工の際は、追加加工時の注意をご参照ください。Please refer to Precaution for additional process when additional process.

許容伝達動力表 曲げ強さ (kW)

Allowable transfer capability table (W) Bending Strength

歯数 z	歯幅 b	焼入 H	回転速度 (min ⁻¹) revolution/min						
			10	100	200	400	800	1,200	1,500
64	20	-	0.65	6.45	11.21	19.11	34.42	-	-
64	32	-	1.03	10.32	17.93	30.57	55.07	-	-
70	30	-	1.070	10.540	18.120	31.220	57.030	-	-
70	30	○	1.134	11.184	19.485	33.932	66.503	-	-
80	30	-	1.250	12.020	20.350	35.640	66.580	-	-
80	30	○	1.323	12.787	21.941	38.821	77.641	-	-

The above references are JGMA standard.

動力の換算式はP26をご参照ください。Please refer to the conversion formulas of power on page P26.

許容伝達動力表 歯面強さ (kW)

Allowable transfer capability table (kW) Surface Durability

回転速度 (min ⁻¹) revolution/min						
10	100	200	400	800	1,200	1,500
-	-	-	-	-	-	-
0.137	1.380	2.430	4.420	8.950	-	-
0.600	6.552	11.768	21.126	42.681	-	-
0.181	1.790	3.120	5.840	12.180	-	-
0.794	8.488	15.014	27.385	56.459	-	-

Memo

目次
CONTENTS

インフォメーション
INFORMATION

ギヤボックス
GEAR BOXES

ノーバッキングギヤ
ANTI BACKLASH SPUR GEARS

歯
齒
GROUND SPUR GEARS

歯
齒
SPUR GEARS

内
歯
齒
INTERNAL GEARS

歯
齒
GROUND RACKS

ラック
RACKS

へりかた・スクリューギヤ
HELICAL GEARS AND SCREW GEARS

ワーム・ワームホイール
WORMS AND WORM WHEELS

かみ歯
齒
BEVEL GEARS

スプロケット
SPROCKETS

技
術
参
照
資
料
REFERENCE DATA

平歯車

SPUR GEARS

モジュール
MODULE

4

圧力角 20° (並歯)
20° PRESSURE ANGLE FULL DEPTH TOOTH

JIS B 1702-1 (ISO) 8 級
System of accuracy : JIS B 1702-1(ISO) class 8



New 仕様変更 省スペース・軽量化。
Specification change Space-saving and weight saving.

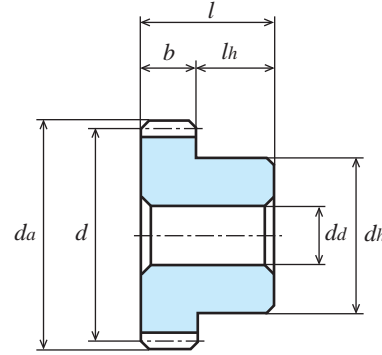

B1形
TYPE B1

S45C 機械構造用炭素鋼 (JIS G 4051)

Material : Carbon Steel (ISO C45)

単位 : mm
Dimensions : mm

商品記号 Catalogue Number	歯数 Number of Teeth z	基準円直径 Reference Diameter d	歯先円直径 Tip Diameter d_a	形 Type	歯幅 Face Width b	穴径 Bore Diameter $d_d(H8)$	ハブ外径 Hub Diameter d_h	ハブ長さ Hub Projection l_h	全長 Overall Length l	重量 Weight $W(kg)$
S4S 14B - 4018N	14	φ56	φ64	B1	40	φ18	φ44	15	55	0.84
S4S 15B - 4020N	15	φ60	φ68	B1	40	φ20	φ48	15	55	0.97
S4S 16B - 4020N	16	φ64	φ72	B1	40	φ20	φ52	15	55	1.13
S4S 18B - 4025N	18	φ72	φ80	B1	40	φ25	φ60	15	55	1.40
S4S 20B - 4025N	20	φ80	φ88	B1	40	φ25	φ68	15	55	1.80

許容伝達動力表 曲げ強さ (kW)

Allowable transfer capability table (W) Bending Strength

歯数 z	歯幅 b	回転速度 (min ⁻¹) revolution/min							回転速度 (min ⁻¹) revolution/min
		10	100	200	400	800	1,200	1,500	100
14	40	0.28	2.83	5.67	11.04	18.86	25.64	31.02	270.25
15	40	0.32	3.17	6.35	12.23	20.70	28.46	34.37	302.72
16	40	0.35	3.52	7.05	13.41	22.51	31.29	37.72	336.14
18	40	0.42	4.24	8.47	15.74	26.05	36.93	44.68	404.90
20	40	0.50	4.97	9.95	18.06	30.19	42.60	51.70	474.62

The above numerical values are equivalent to JGMA formulas as reference only.

動力の換算式は P26 をご参照ください。Please refer to the conversion formulas of power on page P26.

JIS B 1702-1 (ISO) 8 級
System of accuracy : JIS B 1702-1(ISO) class 8



御注文には必ず“フルネームで商品記号”を明記してください。
Please refer to the catalogue reference while ordering.

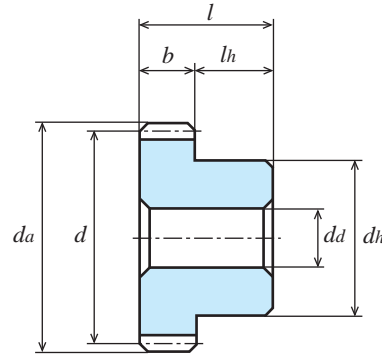

B1形
TYPE B1

S45C 機械構造用炭素鋼 (JIS G 4051) Material : Carbon Steel (ISO C45)

単位 : mm
Dimensions : mm

商品記号 Catalogue Number	歯数 Number of Teeth z	基準円直径 Reference Diameter d	歯先円直径 Tip Diameter da	形 Type	歯幅 Face Width b	穴径 Bore Diameter $da(H8)$	ハブ外径 Hub Diameter dh	ハブ長さ Hub Projection lh	全長 Overall Length l	重量 Weight $W(kg)$
S5S 14B - 5020N	14	φ 70	φ 80	B1	50	φ20	φ55	15	65	1.63
S5S 15B - 5025N	15	φ 75	φ 85	B1	50	φ25	φ60	15	65	1.82
S5S 16B - 5025N	16	φ 80	φ 90	B1	50	φ25	φ65	15	65	2.11
S5S 18B - 5025N	18	φ 90	φ100	B1	50	φ25	φ75	15	65	2.77
S5S 20B - 5030N	20	φ100	φ110	B1	50	φ30	φ85	15	65	3.39

許容伝達動力表 曲げ強さ (kW)

Allowable transfer capability table (W) Bending Strength

歯数 z	歯幅 b	回転速度 (min ⁻¹) revolution/min							回転速度 (min ⁻¹) revolution/min
		10	100	200	400	800	1,200	1,500	100
14	50	0.55	5.48	10.96	20.48	33.97	47.98	58.00	523.32
15	50	0.61	6.14	12.28	22.62	37.57	53.16	64.40	586.35
16	50	0.68	6.81	13.62	24.74	41.36	58.36	70.83	650.33
18	50	0.82	8.19	16.38	28.92	48.95	69.12	83.62	782.12
20	50	0.96	9.62	19.10	33.04	56.58	79.97	96.47	918.68

The above numerical values are equivalent to JGMA formulas as reference only.

動力の換算式は P26 をご参照ください。Please refer to the conversion fomulas of power on page P26.

Memo

目次
CONTENTS

インフォメーション
INFORMATION

ギヤボックス
GEAR BOXES

ノーバックス
ANTI BACKLASH SPUR GEAR
ギヤ

歯研平歯車
GROUND SPUR GEARS

平歯車
SPUR GEARS

内歯車
INTERNAL GEARS

歯研ラック
GROUND RACKS

ラック
RACKS

ヘリカル・スクリューギヤ
HELICAL GEARS AND SCREW GEARS

ウォーム
WORMS AND WORM WHEELS
ウォームホイール

かさ歯車
BEVEL GEARS

スプロケット
SPUR METS

技術資料
REFERENCE DATA



内歯車 (インターナルギヤ)

Internal Gears

商品記号の読み方 Reference of Catalogue Number

IS 50 B 60 A - 03 50
IS 80 B 100 A - 07 05
IS 1 S 120 A - 10 50

歯車の種類 Kind of Gear	モジュールの大きさ Module	材質 Material	歯数 Number of Teeth	形状 Type	-	歯幅 Face Width	外形 Outside Diameter of ring
IS: インターナルスパー internal Gears	モジュールが1未満の場合表示は100倍の数値です。 例 m0.5 → 50 Expressed the unit of module's size. Module 0.5 and 0.8 as multiple of 100. Example m0.5 → 50 m0.8 → 80	B: 黄銅 C3713P C3604B Brass S: S45C Carbon Steel	60～120Tまで、主として12の公倍数が揃っています。 As for the number of teeth, we have the varieties from 60z to 120 z as 12 of common multiple.	A: ハブ無し hubless	内歯車の場合全て“-”です。 Gear without Key Way / without Thread hole.	単位: (mm) Dimension: millimeter	単位: (mm) 例 φ100 → 00 φ105 → 05 φ150 → 50 Dimension: millimeter

※ m0.8 以上で外径 D が 100 以上の商品は下 2 桁の数値の表示になります。

内歯車 (インターナルギヤ) インフォメーション

○ KG 内歯車の特徴

1. モジュールは m0.5, m0.8, m1 の 3 種類で小モジュール中心に規格を充実しました。
2. 外輪のはめあい公差を h8 とし、ハウジング等の穴にそのままはめあう様加工しています。
3. 相手ピニオンは、KG 平歯車の中からお選び下さい。

The Feature of Internal Gears

- 1) Range: Module 0.5, 0.8 and 1.0
- 2) Fit tolerance of the Outer Rim has tolerance of H8, this can be installed at hole of housing without modification.
- 3) Please refer to the KG-catalogue of Spur gear for the sun and planet gears.

○ ご使用上の注意

1. 内歯車の中に入る外歯車の歯数には、制約がありますので注意して下さい。(詳しくは「内歯車の干渉」をご覧ください。)
2. 遊星歯車機構を設計される場合、遊星歯車及び太陽歯車には、歯数の制約と組立条件とがありますので、注意して下さい。

Usage of Precaution

- 1) Note that planet gear has limited number of teeth, refer to the range of number of teeth (see table 1)
- 2) Refer to the interference for planet and sun gears assembly, it has a limited number of teeth for your design.

内歯車 (インターナルギヤ) INTERNAL GEARS

モジュール
MODULE

0.5/0.8

圧力角 20° (並歯)

20° PRESSURE ANGLE FULL DEPTH TOOTH



御注文には必ず“フルネームで商品記号”を明記してください。
Please refer to the catalogue reference while ordering.

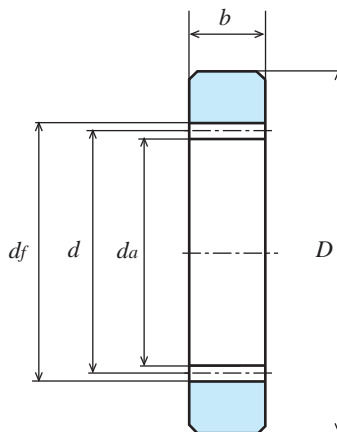

RoHS 対応

2006年11月生産開始分より欧州 RoHS 指令に対応できる商品を提供しています。

We supplied the KG-products with RoHS compliance of EU to all our valued customers since November 2006

C3713P 快削黄銅板、C3604B 快削黄銅棒

Material : Brass (ISO CuZn38Pb2,CuZn39Pb3)

単位 : mm
Dimensions : mm

モジュール Module	商品記号 Catalogue Number	歯数 Number of Teeth z	基準円直径 Reference Diameter d	歯先円直径 Tip Diameter d_a	歯底円直径 Root Diameter d_f	歯幅 Face Width b	外径 Outside Diameter of Ring D	重量 Weight $W(g)$
0.5	IS50B 60A - 0350	60	$\phi 30.0$	$\phi 29.0$	$\phi 31.25$	3	$\phi 50$	32.0
0.5	IS50B 80A - 0360	80	$\phi 40.0$	$\phi 39.0$	$\phi 41.25$	3	$\phi 60$	40.1
0.5	IS50B 90A - 0370	90	$\phi 45.0$	$\phi 44.0$	$\phi 46.25$	3	$\phi 70$	57.6
0.5	IS50B 100A - 0375	100	$\phi 50.0$	$\phi 49.0$	$\phi 51.25$	3	$\phi 75$	62.6
0.5	IS50B 120A - 0380	120	$\phi 60.0$	$\phi 59.0$	$\phi 61.25$	3	$\phi 80$	56.1

C3713P 快削黄銅板、C3604B 快削黄銅棒

Material : Brass (ISO CuZn38Pb2,CuZn39Pb3)

単位 : mm
Dimensions : mm

モジュール Module	商品記号 Catalogue Number	歯数 Number of Teeth z	基準円直径 Reference Diameter d	歯先円直径 Tip Diameter d_a	歯底円直径 Root Diameter d_f	歯幅 Face Width b	外径 Outside Diameter of Ring D	重量 Weight $W(g)$
0.8	IS80B 60A - 0780	60	$\phi 48.0$	$\phi 46.4$	$\phi 50.0$	7	$\phi 80$	191.4
0.8	IS80B 80A - 0790	80	$\phi 64.0$	$\phi 62.4$	$\phi 66.0$	7	$\phi 90$	187.1
0.8	IS80B 90A - 0700	90	$\phi 72.0$	$\phi 70.4$	$\phi 74.0$	7	$\phi 100$	225.1
0.8	IS80B 100A - 0705	100	$\phi 80.0$	$\phi 78.4$	$\phi 82.0$	7	$\phi 105$	216.1
0.8	IS80B 120A - 0720	120	$\phi 96.0$	$\phi 94.4$	$\phi 98.0$	7	$\phi 120$	242.3

S45C 機械構造用炭素鋼 (JIS G 4051)

Material : Carbon Steel (ISO C45)

単位 : mm
Dimensions : mm

モジュール Module	商品記号 Catalogue Number	歯数 Number of Teeth <i>z</i>	基準円直径 Reference Diameter <i>d</i>	歯先円直径 Tip Diameter <i>d_a</i>	歯底円直径 Root Diameter <i>d_f</i>	歯幅 Face Width <i>b</i>	外径 Outside Diameter of Ring <i>D</i>	重量 Weight <i>W(g)</i>
1	IS1S 60A - 1090	60	φ 60.0	φ 58.0	φ 62.5	10	φ 90	277.4
1	IS1S 80A - 1010	80	φ 80.0	φ 78.0	φ 82.5	10	φ 110	351.4
1	IS1S 90A - 1020	90	φ 90.0	φ 88.0	φ 92.5	10	φ 120	388.4
1	IS1S 100A - 1030	100	φ 100.0	φ 98.0	φ 102.5	10	φ 130	425.4
1	IS1S 120A - 1050	120	φ 120.0	φ 118.0	φ 122.5	10	φ 150	499.4

内歯車の干渉

内歯車とピニオン (外歯車) とをかみ合わせるとき、内歯車の歯数が少なかったり、内歯車とピニオンの歯数差が少なかったりすると、組み立てできないことがあります。これらの不都合を、「内歯車の干渉」といい、次表に干渉の種類とその現象と原因を示します。

Interference will occur when design provides insufficient Number of teeth between Internal and Planet gears (External gear) during assembly.

主な使用例 For example

1. 内歯車と外歯車のかみ合い
Engagement between Internal and Pinion.

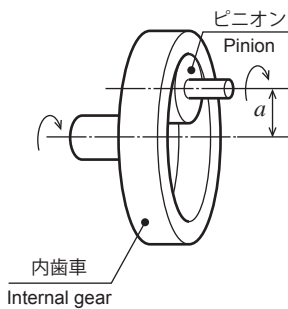

外歯車同士のかみ合いに比べ、中心距離 *a* が短くなり、互いに同じ方向の回転が得られません。Center distance for the Internal gear train is shorter than the external gear train, but can be obtained in the same direction.

伝達比 *u* は

- a) ピニオンが駆動車となる場合
Pinion is driver gear.

$$u = \frac{\text{ピニオンの歯数}}{\text{内歯車の歯数}} \text{ (減速)}$$

$$u = \frac{\text{No. of teeth of pinion}}{\text{No. of teeth of Internal gear}} \text{ (Speed Reducer)}$$

- b) 内歯車が駆動車となる場合
Internal gear is driver gear.

$$u = \frac{\text{内歯車の歯数}}{\text{ピニオンの歯数}} \text{ (増速)}$$

$$u = \frac{\text{No. of teeth of Internal gear}}{\text{No. of teeth of pinion}} \text{ (Speed increaser)}$$

となります。

- 単列遊星歯車機構の基本軸 (2K-H)
Basic gear axis for Planetary gear train mechanism (2K-H).

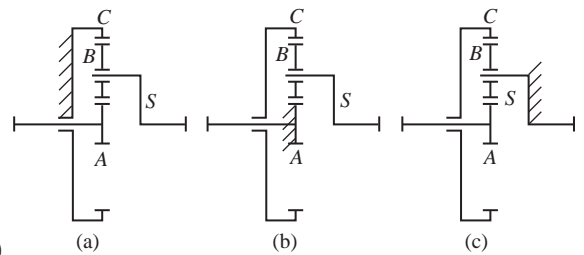

2. 遊星歯車機構
Planetary gear mechanism

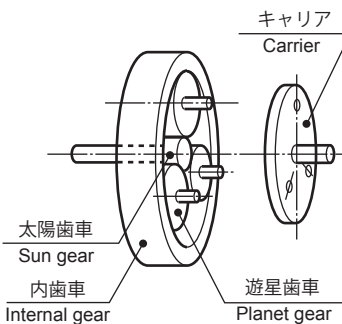

遊星歯車機構は、太陽歯車、遊星歯車、内歯車、キャリア (腕) から構成され、コンパクトで大きな減速比がえられます。

Most mechanism of Planetary gear comes with compact design and high reductive gear ratio consisting of Sun, Planet, Internal gears and Planet carrier.

種類 Type of mechanism	固定要素 Fixed factor	入力 Input	出力 Output	減速比の計算式 Formula of gear ratio	減速比の範囲 Ratio
(a) プラネタリ型 Type of planetary	内歯車 Internal gear	太陽歯車 Sun gear	キャリア Carrier	$\frac{1}{\frac{zC}{zA} + 1}$ (<i>z</i> : Number of teeth)	1/3 ~ 1/12
(b) ソーラ型 Type of solar	太陽歯車 Sun gear	内歯車 Internal gear	キャリア Carrier	$\frac{1}{\frac{zA}{zC} + 1}$	1/1.2 ~ 1/1.7
(c) スター型 Type of star	キャリア (腕) Carrier	太陽歯車 Sun gear	内歯車 Internal gear	$-\frac{1}{\frac{zC}{zA}}$ Input and output axis have opposite rotation	1/2 ~ 1/11

・ *z* は歯数を示し、添付の A、C は各々太陽歯車、内歯車を示す。

・ 負記号は、入力回転と反対の出力回転方向を示す。

z: Number of teeth, A&C: Sun and internal Gears.

[-]: Expressed output rotated direction against input rotation.

内歯車 (インターナルギヤ)

INTERNAL GEARS

Please refer to the causes and types of interference as follows.

Interference of Internal Gear (Table 1)

There are restriction of the number of teeth for the planet gear and the sun gear when the planetary gear mechanism is designed.

干渉 Interference	現象 Phenomenon	原因 Cause	干渉 Interference	現象 Phenomenon	原因 Cause
インボリュート干渉 Involute interference	ピニオンの歯元に内歯車の歯先が食い込んで、回転できない。 Unworkable conditions when a Tooth tip of Internal gear cuts into Dedendum of pinion during operations.	ピニオンの歯数が少ない。 Insufficient of Number of Teeth for Pinion gear.	トリミング干渉 Trimming interference	組付けの際、ピニオンは、軸方向に入れる事はできても、半径方向に出入れできない。 During assembling, pinion can be assembled to axial direction but not to radius direction.	トロコイド干渉と同じ Same as Trochoid interference.
トロコイド干渉 Trochoid interference	噛合を終えたピニオン歯先がふたたび内歯車の歯先と接触し、回転できない。 Tip of pinion after engaging with Sun gear interferes to Tooth tip of Internal gear causing unworkable conditions.	内・外歯車の歯数差が少ない。 Difference in No. of teeth between Internal and Planet is insufficient.	隅肉干渉 Fillet interference	内歯車の歯元隅肉部にピニオン歯先が接触し、回転できない。 Tooth tip of pinion touched Dedendum fillet of Internal gear causing unworkable condition.	ピニオンの歯数が少ない (ピニオンの歯たけが低い) Insufficient No. of teeth for pinion. (insufficient Tooth depth of pinion.)

遊星歯車の組立条件 Relationship among the gears in a planetary gear mechanism

遊星歯車を設計する場合、次の条件を満足するような歯数構成としてください。

When designing Planet gear, please achieve following conditions.

- ① 内歯車の歯数 = 太陽歯車の歯数 + 2 × (遊星歯車の歯数)
No of teeth of Internal gear = (No. of teeth of Sun gear + 2) × No. of teeth of Planet gear.
- ②
$$\frac{\text{内歯車の歯数} + \text{太陽歯車の歯数}}{\text{遊星歯車の使用個数}} = \text{整数であること}$$

$$\frac{\text{No. of teeth of (Internal gear + Sun gear)}}{\text{The number of Planet gear}} = \text{Should be Integer number}$$
- ③ 遊星歯車同志の歯先干渉を起こさないこと
Prevent the Tip interference among Planet gears.
$$m(ZB+2) < m(ZA+ZB) \sin(\pi/n)$$
 (n: 遊星歯車の個数 The number of Planet gear π [rad])

KG 内歯車とかみ合う遊星歯車の歯数範囲 Range of number of teeth for pinion and KG-Internal gears

内歯車の歯数 Number of teeth of Internal gear	遊星歯車の歯数範囲 Range of number of teeth for pinion	内歯車の歯数 Number of teeth of Internal gear	遊星歯車の歯数範囲 Range of number of teeth for pinion
60	21 ~ 44	100	19 ~ 84
80	20 ~ 64	120	19 ~ 104
90	19 ~ 74		

内歯車 (インターナルギヤ)

INTERNAL GEARS

組み合わせの例 The combination of KG STOCK GEARS

内歯車歯数 No. of teeth of Internal gear	プラネット 個 数 The number of Planet gears.	太陽歯車 歯 数 No. of teeth of Sun gears	遊星歯車 歯 数 No. of teeth of Planet gear	プラネタリ型 減速比 Gear ratio of planetary type	スター型 減速比 Gear ratio of star type	ソーラ型 減速比 Gear ratio of solar.
60	3	12	24	1/6.00	1/5.00	1/1.20
60	4	16	22	1/4.75	1/3.75	1/1.26
80	3	16	32	1/6.00	1/5.00	1/1.20
80	3	40	20	1/3.00	1/2.00	1/1.50
80	4	20	30	1/5.00	1/4.00	1/1.25
80	4	32	24	1/3.50	1/2.50	1/1.40
80	4	40	20	1/3.00	1/2.00	1/1.50
80	5	40	20	1/3.00	1/2.00	1/1.50
90	3	18	36	1/6.00	1/5.00	1/1.20
90	3	30	30	1/4.00	1/3.00	1/1.33
90	4	18	36	1/6.00	1/5.00	1/1.20
90	4	30	30	1/4.00	1/3.00	1/1.33
90	4	50	20	1/2.80	1/1.80	1/1.55
90	5	30	30	1/4.00	1/3.00	1/1.33
90	5	50	20	1/2.80	1/1.80	1/1.55

内歯車歯数 No. of teeth of Internal gear	プラネット 個 数 The number of Planet gears.	太陽歯車 歯 数 No. of teeth of Sun gears	遊星歯車 歯 数 No. of teeth of Planet gear	プラネタリ型 減速比 Gear ratio of planetary type	スター型 減速比 Gear ratio of star type	ソーラ型 減速比 Gear ratio of solar.
100	3	20	40	1/ 6.00	1/ 5.00	1/1.20
100	3	50	25	1/ 3.00	1/ 2.00	1/1.50
100	4	20	40	1/ 6.00	1/ 5.00	1/1.20
100	4	40	30	1/ 3.50	1/ 2.50	1/1.40
100	5	40	30	1/ 3.50	1/ 2.50	1/1.40
100	5	50	25	1/ 3.00	1/ 2.00	1/1.50
120	3	12	54	1/11.00	1/10.00	1/1.10
120	3	24	48	1/ 6.00	1/ 5.00	1/1.20
120	3	30	45	1/ 5.00	1/ 4.00	1/1.25
120	3	48	36	1/ 3.50	1/ 2.50	1/1.40
120	3	60	30	1/ 3.00	1/ 2.00	1/1.50
120	4	24	48	1/ 6.00	1/ 5.00	1/1.20
120	4	40	40	1/ 4.00	1/ 3.00	1/1.33
120	4	80	20	1/ 2.50	1/ 1.50	1/1.66

The above variety of Sun, Planet and Internal gear are KG-STOCK GEARS series.

この表の太陽歯車、遊星歯車はほとんど規格歯車で揃っています。

※この他にも太陽歯車、遊星歯車をいろいろ組合せれば多くの減速比が求められます。(減速比の計算式参照のこと)

※組合せを2重にすれば減速比は(1段目の比率) × (2段目の比率)となり高比率の減速になります。

High ratio can be obtained by doubly jointing the planetary gear boxes.

To obtain the variety of gear ratio when combining with another Sun and Planet gears, please refer to the calculation of gear ratio.

To obtain high gear ratio when assembling the double and triple combinations.

Memo

目次
CONTENTS

インフォメーション
INFORMATION

ギヤボックス
GEAR BOXES

ノーバッキング
ANTI BACKLASH SPUR GEAR
ギヤ

歯研平歯車
GROUND SPUR GEAR

平歯車
SPUR GEAR

内歯車
INTERNAL GEAR

歯研ラック
GROUND RACK

ラック
RACK

ヘリカル・スクリューギヤ
HELICAL GEAR AND SCREW GEAR

ウォーム
WORM AND WORM WHEEL
ウォームホイール

かさ歯車
BEVEL GEAR

スプロケット
SPUR GEAR

技術資料
REFERENCE DATA



歯面研削小モジュールラック 精密歯研ラック

歯面研削サーキュラーピッチラック

精密歯研 CP ラック

精密歯研 CP ピニオン

Ground Racks, Circular Pitch Ground Racks
and Pinion Gears.

商品記号の読み方 Reference of Catalogue Number

歯車の種類 Kind of Gear	ピッチ Circular Pitch	モジュール Module	材質 Material	全長 Overall Length	歯幅 Face Width	全高さ Overall Thickness
RKG : Ground Rack (歯研ラック) RKGP : Ground Circular Pitch Rack (歯研 CP ラック)	2 : CP2 5 : CP5 2 : 2 Millimeter 5 : 5 Millimeter	m : 0.5 0.8 1.0 1.5 2.0 2.5 3.0 モジュールが 1 未満の表示は 100 倍の数値になります Expressed the unit of module's size. Module 0.5 and 0.8 as multiple of 100. 例 Example m0.5 → 50 m0.8 → 80	S : S45C 素材調質 HS40 ~ 45 SCM435 歯部高周波焼入 HRC49 ~ 55 Material : Carbon Steel Applied thermal refining of HS40~45 to the raw material. Chromium Molybdenum Steel, complete with high frequency Induction Hardening. (HRC49 to 55)	この数値の 100 倍が全長です。 Increase hundred times from these numbers. Example 2 → 200 millimeter 3 → 300 millimeter	単位 : mm Dimension : millimeter	単位 : mm Dimension : millimeter

歯車の種類 Kind of Gear	ピッチ Circular Pitch	材質 Material	穴仕上 Bore Processed	歯数 Number of Teeth
SGP : Circular Pitch Ground Spur Gear (歯研 CP スパーギヤ) Circular pitch pinions	2 : CP2 Pitch : 2mm (0.636 module) 5 : CP5 Pitch : 5mm (1.591 module)	S : SCM435、440 歯部高周波焼入 HRC49 ~ 55 Material : Chromium Molybdenum Steel, complete with high frequency Induction Hardening. (HRC 49 to 55).	【一】：研削仕上 Ground bore. without threaded hole/ without Set Screw. 【*】：研削仕上 2 箇所止めネジ付き with two threaded holes/ without Set Screw.	Z : 20、25、30

メカトロ分野、工作機械および測定機器等の精密な動きを要求されるところにベストマッチする精密歯研ラックです。

The precision gears are applied and demanded in the Mechatronics, Machine Tools, and Measured Instruments.

歯研ラック GROUND RACKS

モジュール **0.5/0.8/1/1.5** 圧力角 20° (並歯)
MODULE 20° PRESSURE ANGLE FULL DEPTH TOOTH

素材調質 HS40 ~ 45
Applied thermal refining with hardness of HS 40 ~ 45 to the raw material.

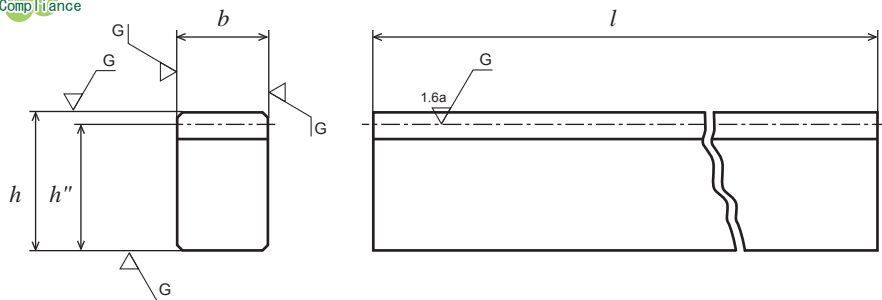

S45C 機械構造用炭素鋼 (JIS G 4051) Material : Carbon Steel (ISO C45)

単位 : mm
Dimensions : mm

モジュール Module <i>m</i>	商品記号 Catalogue Number	全長 Overall Length <i>l</i>	両端面加工 Both Ends Processed <i>p</i>	有効歯数 Effective Number of Teeth <i>z</i>	かみ合い高さ Datum Line <i>h''</i>	歯幅 Face Width <i>b(hδ)</i>	高さ Overall Thickness <i>h(hδ)</i>	重量 Weight <i>W(kg)</i>
0.5	RKG50S 2 - 0812	201.06	0.02 ~ 0.08	128	11.5	8	12	0.14
0.8	RKG80S 2 - 0812	201.06	0.03 ~ 0.12	80	11.2	8	12	0.14
1.0	RKG1S 3 - 1015	301.59	0.03 ~ 0.12	96	14.0	10	15	0.32
1.5	RKG1.5S 3 - 1520	301.59	0.06 ~ 0.18	64	18.5	15	20	0.64

相手ピニオンは当社歯研平歯車 SG シリーズよりお選び下さい。

KG-Ground Rack is able to match with other gear makers however it is advisable to use KG-Ground Spur gear series for best result.

S45C 精密歯研ラックの主な特徴

- 精度
素材真直度
最終加工精度は 0.04 mm 以内に仕上げております。
素材平行度
四面研削仕上にて 0.01 mm 以内に仕上げております。
累積ピッチ誤差
0.025 mm (200l) 以内に仕上げております。
- アンチバックラッシュギヤとしての使用
近年アンチバックラッシュ機構のニーズが増えております。歯研ラックを使用致しますとバックラッシュを『0』に近づける事が出来ます。ただしこの場合は高精度の取り付けが要求されますのでご注意ください。
- 素材経年変化について
素材調質 (Hs40 ~ 45) を施しておりますが、内部応力により経年変化をすることがあります。

Feature of C45 Ground Racks

- Precision
 - Straightness: 0.04mm and below after processed.
 - Parallelism: 0.01mm and below after grinding process on all four faces.
 - Total cumulative pitch deviation: 0.025mm (for 200 length) and below after processed.
- To use with Anti Backlash gear.
Due to the recent increase demand of anti backlash mechanism, zero backlash can be obtained by matching the Ground Spur Gear with Anti Backlash gear. However using this method will require the assembler to be very precise with this assembly.
- The secular change of the material.
Ground Rack's material has been thermal refined but secular change may occur due to the inner stress and characteristic.

両端面加工詳細 (ピッチ合わせ) Detail of both ends processed

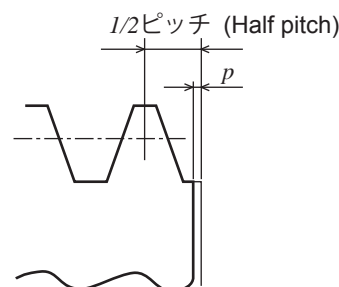

歯研ラック GROUND RACKS

モジュール 1/1.5/2/2.5/3 圧力角 20° (並歯)
MODULE 1/1.5/2/2.5/3 20° PRESSURE ANGLE FULL DEPTH TOOTH

歯部高周波焼き入れ HRC49 ~ 55
Gear tooth surface completed with induction hardening, Hardness HRC49 to 55.

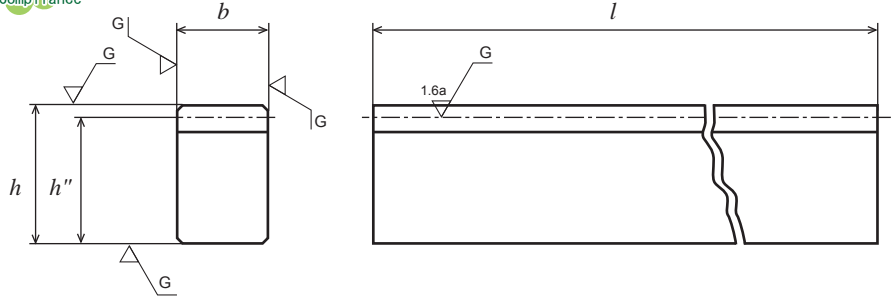

SCM435 クロムモリブデン鋼 (JIS G 4305)
Material : Chromium Molybdenum Steel (ISO 34CrMo4)

単位 : mm
Dimensions : mm

モジュール Module <i>m</i>	商品記号 Catalogue Number	全長 Overall Length <i>l</i>	両端面加工 Both Ends Processed <i>p</i>	有効歯数 Effective Number of Teeth <i>z</i>	かみ合い高さ Datum Line <i>h''</i>	歯幅 Face Width <i>b(hδ)</i>	高さ Overall Thickness <i>h(hδ)</i>	重量 Weight <i>W(kg)</i>
● 1	RKG1S 5 - 1015H	505.80	0.03 ~ 0.12	161	14	10	15	0.55
● 1	RKG1S 10 - 1015H	1021.02	0.03 ~ 0.12	325	14	10	15	1.12
● 1.5	RKG1.5S 5 - 1515H	504.23	0.06 ~ 0.18	107	13.5	15	15	0.80
● 1.5	RKG1.5S 10 - 1515H	1008.45	0.06 ~ 0.18	214	13.5	15	15	1.59
● 2	RKG2S 5 - 2020H	502.66	0.06 ~ 0.18	80	18	20	20	1.41
● 2	RKG2S 10 - 2020H	1005.31	0.06 ~ 0.18	160	18	20	20	2.82
● 2.5	RKG2.5S 5 - 2525H	502.66	0.06 ~ 0.18	64	22.5	25	25	2.21
● 2.5	RKG2.5S 10 - 2525H	1005.31	0.06 ~ 0.18	128	22.5	25	25	4.41
● 3	RKG3S 5 - 3030H	499.51	0.10 ~ 0.25	53	27	30	30	3.16
● 3	RKG3S 10 - 3030H	1008.45	0.10 ~ 0.25	107	27	30	30	6.37

●の商品は新商品です。
Products with ● marks are new item.

焼入れの影響で、歯部以外も硬化している場合がございます。
歯底付近 (2 ~ 3mm 程度) の追加工は御注意ください。
Take note that areas of the gear teeth and near gear teeth may occur the condition of low machinability by the influence of induction hardening processed.

相手ピニオンは当社歯研平歯車 SG シリーズよりお選び下さい。
KG-Ground Rack is able to match with other gear makers however it is advisable to use KG-Ground Spur gear series for best result.

目次 CONTENTS

インフォメーション INFORMATION

ギヤボックス GEAR BOXES

ノーバクシスギヤ ANTI BACKLASH SPUR GEAR

歯研平歯車 GROUND SPUR GEARS

平歯車 SPUR GEARS

内歯車 INTERNAL GEARS

歯研ラック GROUND RACKS

ラック RACKS

へリカル・スクリューギヤ HELICAL GEARS AND SCREW GEARS

ウォーム・ウォームギヤ WORMS AND WORM GEARS

かさ歯車 BEVEL GEARS

スプロケット SPROCKETS

技術資料 REFERENCE DATA

歯研 CP ラック

GROUND CP RACK

ピッチ **2/5** 圧力角 20° (並歯)
 PITCH **2/5** 20° PRESSURE ANGLE FULL DEPTH TOOTH

素材調質 HS40 ~ 45
 Applied thermal refining with hardness of HS 40 ~ 45 to the raw material.

Please refer to the catalogue reference while ordering.

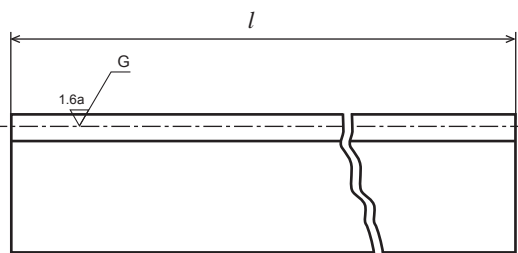
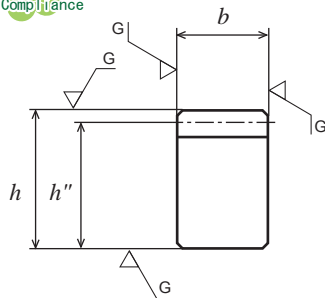

S45C 機械構造用炭素鋼 (JIS G 4051)

Material : Carbon Steel (ISO C45) Able to obtain integer number of length, if selected from any number of teeth due to integer pitch.

単位 : mm
 Dimensions : mm

ピッチ Circular Pitch <i>cp</i>	商品記号 Catalogue Number	全長 Overall Length <i>l</i>	両端面加工 Both Ends Processed <i>p</i>	有効歯数 Effective Number of Teeth <i>z</i>	かみ合い高さ Datum Line <i>h''</i>	歯幅 Face Width <i>b(hδ)</i>	高さ Overall Thickness <i>h(hδ)</i>	重量 Weight <i>W(kg)</i>
2	RKGP2S 2-0812	200	0.02 ~ 0.08	100	11.364	8	12	0.14
5	RKGP5S 3-1520	300	0.04 ~ 0.16	60	18.409	15	20	0.65

Applied thermal refining with hardness of HS 40 ~ 45 to the material.

両端面加工詳細 (ピッチ合わせ)

Details of both ends processed

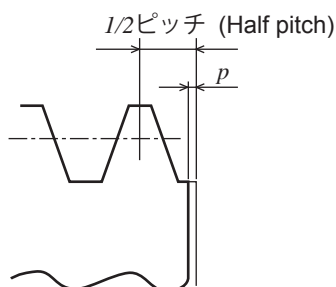

齒研 CP ラックピニオン GROUND CP RACK PNION

ピッチ **2/5** 圧力角 20° (並歯)
PITCH **2/5** 20° PRESSURE ANGLE FULL DEPTH TOOTH

歯部高周波焼き入れ HRC49 ~ 55
JIS B 1702-1 (ISO) 5 級
System of accuracy: JIS B1702-1(ISO) class 5



New **ねじを2箇所 (120°配) にしました。**
New item with two thread holes (120°)

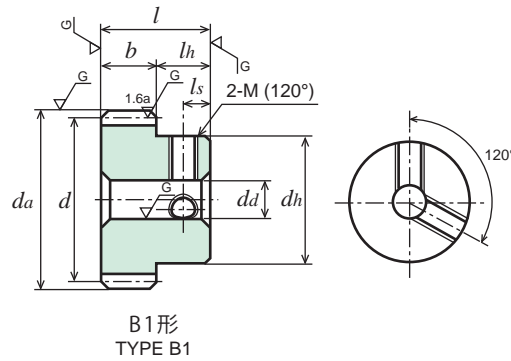

SCM435、440 クロムモリブデン鋼 (JIS G 4053) Material : Chromium Molybdenum Steel (ISO 34CrMo4, 42CrMo4)

単位 : mm
Dimensions : mm

ピッチ Circular Pitch <i>cp</i>	商品記号 Catalogue Number	歯数 Number of Teeth <i>z</i>	基準円直径 Reference Diameter <i>d</i>	歯先円直径 Tip Diameter <i>da</i>	形 Type	歯幅 Face Width <i>b</i>	穴径 Bore Diameter <i>da(H7)</i>	ハブ外径 Hub Diameter <i>dh</i>	ハブ長さ Hub Projection <i>lh</i>	全長 Overall Length <i>l</i>	ねじ Set Screw		1回転距離 Distance of one turn 注)	重量 Weight <i>W(g)</i>
											2-M	<i>ls</i>		
2	SGP2S - 20	20	φ12.73	φ14.01	B1	8	φ 5	φ10	7	15	-	-	40	10.0
2	SGP2S * 20	20	φ12.73	φ14.01	B1	8	φ 5	φ10	7	15	2-M3	3.5	40	9.6
2	SGP2S - 25	25	φ15.92	φ17.19	B1	8	φ 6	φ12	7	15	-	-	50	15.4
2	SGP2S * 25	25	φ15.92	φ17.19	B1	8	φ 6	φ12	7	15	2-M3	3.5	50	14.9
2	SGP2S - 30	30	φ19.10	φ20.37	B1	8	φ 6	φ15	7	15	-	-	60	24.4
2	SGP2S * 30	30	φ19.10	φ20.37	B1	8	φ 6	φ15	7	15	2-M4	3.5	60	23.7
5	SGP5S - 20	20	φ31.83	φ35.01	B1	15	φ10	φ25	10	25	-	-	100	117.1
5	SGP5S - 25	25	φ39.79	φ42.97	B1	15	φ10	φ30	10	25	-	-	125	187.0
5	SGP5S - 30	30	φ47.75	φ50.93	B1	15	φ10	φ40	10	25	-	-	150	294.8

注) 1回転移動距離...ピニオンがラック上で1回転した時に移動する距離です。
Traveling distance of one turn.
Obtain traveling amount of integer number, revolved one turn of the CP Pinion on the CP Rack.

Gear tooth surface completed with induction hardening, Hardness HRC49 to 55.

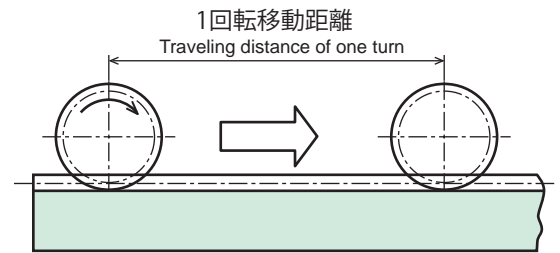

許容伝達動力表 曲げ強さ (kW)

Allowable transfer capability table (kW) Bending Strength

商品記号 Catalogue Numbers	回転速度 (min ⁻¹) revolution/min						
	100	250	500	800	1,000	1,500	2,000
SGP2S - 20	0.038	0.096	0.191	0.306	0.383	0.574	0.765
SGP2S - 25	0.053	0.132	0.263	0.421	0.526	0.790	1.053
SGP2S - 30	0.068	0.169	0.338	0.540	0.675	1.013	1.350
SGP5S - 20	0.448	1.121	2.242	3.587	4.483	6.725	8.892
SGP5S - 25	0.617	1.542	3.084	4.935	6.169	9.225	11.99
SGP5S - 30	0.791	1.978	3.955	6.328	7.910	11.65	15.07

The above numerical values are equivalent to JGMA formulas as reference only.

動力の換算式は P26 をご参照ください。Please refer to the conversion formulas of power on page P26.

許容伝達動力表 歯面強さ (kW)

Allowable transfer capability table (kW) Surface Durability

商品記号 Catalogue Numbers	回転速度 (min ⁻¹) revolution/min						
	100	250	500	800	1,000	1,500	2,000
SGP2S - 20	0.007	0.019	0.038	0.063	0.079	0.121	0.163
SGP2S - 25	0.011	0.030	0.061	0.100	0.126	0.193	0.260
SGP2S - 30	0.017	0.043	0.090	0.146	0.185	0.282	0.381
SGP5S - 20	0.091	0.238	0.490	0.800	1.010	1.542	2.066
SGP5S - 25	0.146	0.379	0.782	1.277	1.612	2.454	3.230
SGP5S - 30	0.214	0.556	1.146	1.871	2.362	3.541	4.638

つなぎ用ゲージ GAUGE RACKS

モジュール 0.5/0.8/1/1.5 ピッチ 2/5^{CP} 圧力角 20° (並歯)
MODULE PITCH 20° PRESSURE ANGLE FULL DEPTH TOOTH

材質 : S45C Material : S45C
素材調質 HS40 ~ 45
Applied thermal refining with hardness of HS 40 ~ 45 to the raw material.

材質 : SCM435 Material : SCM435
歯部高周波焼入 HRC49 ~ 55
Gear tooth surface completed with induction hardening.
Hardness HRC 49 to 55.

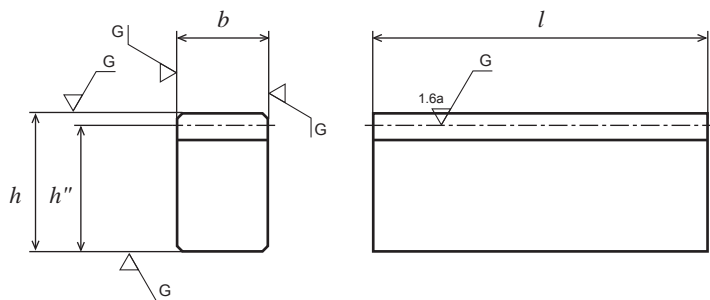

ラックつなぎ用ゲージ (歯面研削品) Material : Carbon Steel (ISO C45)

単位 : mm
Dimensions : mm

モジュール Module <i>m</i>	商品記号 Catalogue Number	材質 Material <i>M</i>	全長 Overall Length <i>l</i>	歯数 Number of Teeth <i>z</i>	かみ合い高さ Datum Line <i>h''</i>	歯幅 Face Width <i>b(h8)</i>	高さ Overall Thickness <i>h(h8)</i>	重量 Weight <i>W(g)</i>
0.5	RKG50S - G	S45C	45.3	29	11.5	8	12	32.7
0.8	RKG80S - G	S45C	44.9	18	11.2	8	12	31.5
1.0	RKG1S - G	S45C	43.6	14	14.0	10	15	47.9
1.5	RKG1.5S - G	S45C	41.9	9	18.5	15	20	91.2
2.0	RKG2S - GH	SCM435	94	15	18	20	20	264.6
2.5	RKG2.5S - GH	SCM435	94	12	22.5	25	25	413.4
3.0	RKG3S - GH	SCM435	94	9	27	30	30	595.3

● の商品は新商品です。
Products with ● marks are new item.

CP ラックつなぎ用ゲージ (歯面研削品) Material : Carbon Steel (ISO C45)

単位 : mm
Dimensions : mm

ピッチ Circular Pitch <i>cp</i>	商品記号 Catalogue Number	材質 Material <i>M</i>	全長 Overall Length <i>l</i>	歯数 Number of Teeth <i>z</i>	かみ合い高さ Datum Line <i>h''</i>	歯幅 Face Width <i>b(h8)</i>	高さ Overall Thickness <i>h(h8)</i>	重量 Weight <i>W(g)</i>
2	RKGP2S - G	S45C	45.7	23	11.364	8	12	32.6
5	RKGP5S - G	S45C	39.4	8	18.409	15	20	85.4

ラックつなぎ用ゲージの使用法

複数のラックをつないで使用する場合、㉑ ㉒ ラック間の最適なピッチ設定には右図の様にラックつなぎ用ゲージをご利用下さい。

Numerous Rack Gears between ㉑ and ㉒ to be joint, please apply the Gauge Rack for the best fit of the pitch.
Refer to the picture on the right.



Memo

目次
CONTENTS

インフォメーション
INFORMATION

ギヤボックス
GEAR BOXES

ノーバッキングギヤ
ANTI BACKLASH SPUR GEARS

歯研平歯
GROUND SPUR GEARS

平歯
SPUR GEARS

内歯
INTERNAL GEARS

歯研ラック
GROUND RACKS

ラック
RACKS

へりかき・スクリューギヤ
HELICAL GEARS AND SCREW GEARS

ウォーム・ウォームホイール
WORMS AND WORM WHEELS

かさ歯
BEVEL GEARS

スプロケット
SPROCKETS

技術資料
REFERENCE DATA

Memo

目次
CONTENTS

インフォメーション
INFORMATION

ギヤボックス
GEAR BOXES

ノーバックラッシュギヤ
ANTI BACKLASH SPUR GEARS

歯研平歯車
GROUND SPUR GEARS

平歯車
SPUR GEARS

内歯車
INTERNAL GEARS

歯研ラック
GROUND RACKS

ラック
RACKS

ヘリカル・スクリューギヤ
HELICAL GEARS AND SCREW GEARS

ウォーム・ウォームホイール
WORMS AND WORM WHEELS

かさ歯車
BEVEL GEARS

スプロケット
SPURKETS

技術資料
REFERENCE DATA



モジュールサイズ

ラック

サーキュラーピッチ

CP ラック

CP ラックピニオン

Racks (Metric and Circular Pitch) and Circular Pitch Pinion.

商品記号の読み方 Reference of Catalogue Number

ORK 50 SU 2 - 08 15

RK 75 SU 2 - 08 08

RK 1.5 SD 10 - 16 16 M

RK 2 SD 16 - 20 25

RKP 5 SD 5 - 16 16

軸径 Shaft Diameter	有効噛合長 Effective length of Action
単位：(mm) Dimension : millimeter	単位：(mm) Dimension : millimeter

歯車の種類 Kind of Gear	ピッチ Circular Pitch	モジュール Module	材質 Material	全長 Overall Length	歯幅 Face Width	全高さ Overall Thickness	取付穴 Fixed holes
RK : Rack (ラック) Module pitch Racks ORK : Round Rack (丸ラック) Round Racks RKP : Circular Rack (CP ラック) Circular Pitch Racks	2 : CP2 Pitch : 2 millimeter 5 : CP5 Pitch : 5 millimeter 10 : CP10 Pitch : 10 millimeter	モジュールが 1 未満の表示は 100 倍の数值になります。 例 m0.5 → 50 m0.75 → 75 Expressed the unit of module's size. Module 0.3, 0.5, 0.75 and 0.8 as multiple of 100. Example m0.5 → 50	B : 黄銅 Brass SU : ステンレス SUS304 Stainless Steel SD : S45C Carbon Steel	この数値の 100 倍が全長です Expressed overall length : Multiplication of 100 from the numbers : For Example : 2 as 200millimeter	単位：(mm) Dimension : millimeter	単位：(mm) Dimension : millimeter	取付穴 With fixed holes

SP 2 S - 20

歯車の種類 Kind of Gear	ピッチ Circular Pitch	材質 Material	穴仕上 Bore Processed	歯数 Number of Teeth
SP : Circular SPUR GEAR (CP スパーギヤ) Circular pitch pinions	2 : CP2 Pitch : 2mm (0.636module) 5 : CP5 Pitch : 5mm (1.591module) 10 : CP10 Pitch : 10mm (3.183module)	S : S45C Carbon Steel	【-】: キーみぞ、ネジ穴無し 旋削仕上げ Gear without key way / without threaded hole. 【*】: ネジ穴付 旋削仕上げ Gear with two threaded holes / with two set screws.	P2 : 15,20,25,30 P5 : 15,16,20,24,25,30 P10 : 20,25,30

丸ラック

ROUND RACKS

モジュール **0.5/0.75/0.8/1** 圧力角 20° (並歯)
 MODULE 20° PRESSURE ANGLE FULL DEPTH TOOTH

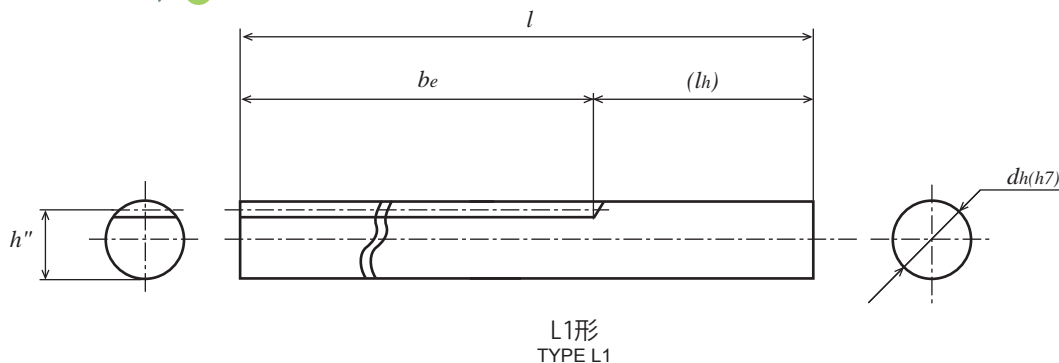

柄付き丸ラック SUS304 ステンレス鋼

Material : Stainless Steel SUS304 (JIS G 4303)

単位 : mm
 Dimensions : mm

モジュール Module <i>m</i>	商品記号 Catalogue Number	全長 Overall Length <i>l</i>	有効歯数 Effective Number of Teeth <i>z</i>	有効かみ合い長さ Effective Datum Length <i>be</i>	かみ合い高さ Datum Line <i>h''</i>	軸径 Shaft Diameter <i>dh(h7)</i>	柄長さ Length of Stem <i>lh</i>	重量 Weight <i>W(g)</i>
0.5	ORK50SU 2 - 0815	200	95	149	7.5	φ 8	50	78
0.75	ORK75SU 2 - 0815	200	63	148	7.25	φ 8	50	76
0.8	ORK80SU 2 - 0815	200	59	148	7.2	φ 8	50	76
1	ORK1SU 3 - 1024	300	76	238	9	φ 10	60	177

全長の呼びが 200mm は、202mm ± 1mm
 全長の呼びが 300mm は、305mm ± 1mm

Actual tolerances and length for 200.0 mm: 202.0 mm +/-1.0 mm
 Actual tolerances and length for 300.0 mm: 305.0 mm +/-1.0 mm

目次 CONTENTS
 インフォメーション INFORMATION
 ギヤボックス GEAR BOXES
 ノーバックラッシュギヤ ANTI BACKLASH SPUR GEARS
 歯研平歯車 GROUND SPUR GEARS
 平歯車 SPUR GEARS
 内歯車 INTERNAL GEARS
 歯研ラック GROUND RACKS
 ラック RACKS
 ヘリカルスクリューギヤ HELICAL GEARS AND SCREW GEARS
 ワーム WORMS AND WORM WHEELS
 かさ歯車 BEVEL GEARS
 スプロケット SPURGEETS
 技術資料 REFERENCE DATA



御注文には必ず“フルネームで商品記号”を明記してください。
 Please refer to the catalogue reference while ordering.

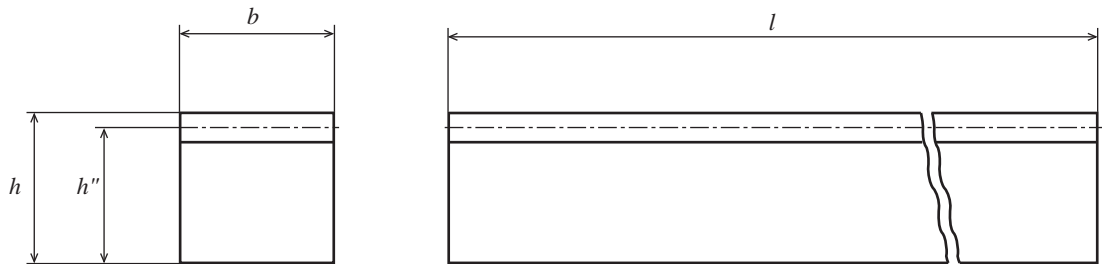

C3604B 快削黄銅

Material : Brass (ISO CuZn39Pb3)

単位 : mm
Dimensions : mm

モジュール Module <i>m</i>	商品記号 Catalogue Number	全長 Overall Length <i>l</i>	両端面加工 Both Ends Processed <i>p</i>	有効歯数 Effective Number of Teeth <i>z</i>	かみ合い高さ Datum Line <i>h''</i>	歯幅 Face Width <i>b(h1l)</i>	高さ Overall Thickness <i>h(h1l)</i>	重量 Weight <i>W(g)</i>
0.3	RK30B 2 - 0308	200	-	210	7.7	3	8	38
0.5	RK50B 2 - 0308	200	-	125	7.5	3	8	37
0.5	RK50B 2 - 0808	200	-	125	7.5	8	8	98
0.5	RK50B 5 - 0810	505	-	319	9.5	8	10	313
0.75	RK75B 2 - 0308	200	-	82	7.25	3	8	35
0.75	RK75B 2 - 0808	200	-	82	7.25	8	8	95
0.75	RK75B 5 - 0310	505	-	212	9.25	3	10	115
0.75	RK75B 5 - 0810	505	-	212	9.25	8	10	307
0.8	RK80B 2 - 0707	200	-	77	6.2	7	7	70
0.8	RK80B 5 - 0510	505	-	198	9.2	5	10	191
0.8	RK80B 5 - 0710	505	-	198	9.2	7	10	268

RoHS 対応

2006年11月生産開始分より欧州 RoHS 指令に対応できる商品を提供しています。
 We supplied the KG-products with RoHS compliance of EU to all our valued customers since November 2006

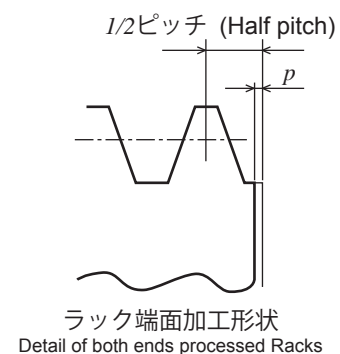
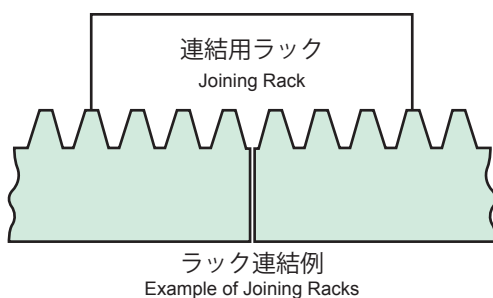



RoHS指令対応
RoHS Compliance



SUS304 ステンレス鋼 (JIS G 4303)

Material : Stainless Steel SUS304 (JIS G 4318)

単位 : mm
Dimensions : mm

モジュール Module <i>m</i>	商品記号 Catalogue Number	全長 Overall Length <i>l</i>	両端面加工 Both Ends Processed <i>p</i>	有効歯数 Effective Number of Teeth <i>z</i>	かみ合い高さ Datum Line <i>h''</i>	歯幅 Face Width <i>b(h12)</i>	高さ Overall Thickness <i>h(h12)</i>	重量 Weight <i>W(g)</i>
0.5	RK50SU 2 - 0310	202 ~ 205	-	126	9.5	3	10	45
0.5	RK50SU 2 - 0808	202 ~ 205	-	126	7.5	8	8	95
0.5	RK50SU 5 - 0810	505 ~ 508	-	319	9.5	8	10	300
0.75	RK75SU 2 - 0310	202 ~ 205	-	83	9.25	3	10	44
0.75	RK75SU 2 - 0808	202 ~ 205	-	83	7.25	8	8	91
0.75	RK75SU 5 - 0810	505 ~ 508	-	212	9.25	8	10	295
0.8	RK80SU 2 - 0707	202 ~ 205	-	78	6.2	7	7	70
0.8	RK80SU 5 - 0510	505 ~ 508	-	198	9.2	5	10	183
0.8	RK80SU 5 - 0710	505 ~ 508	-	198	9.2	7	10	256
1	RK1SU 3 - 1010	303 ~ 306	-	94	9	10	10	210
1	RK1SU 5 - 0810	505 ~ 508	-	158	9	8	10	280
1	RK1SU 5 - 1010	505 ~ 508	-	158	9	10	10	360
1.5	RK1.5SU 3 - 1616	303 ~ 306	-	62	14.5	16	16	0.55(kg)
1.5	RK1.5SU 5 - 1616	503 ~ 506	-	105	14.5	16	16	0.92(kg)
1.5	RK1.5SU 10 - 1219	1008.5	0.06 ~ 0.18	214	17.5	12	19	1.67(kg)
1.5	RK1.5SU 10 - 1616	1008.5	0.06 ~ 0.18	214	14.5	16	16	1.83(kg)
2	RK2SU 10 - 1420	1005.3	0.06 ~ 0.18	160	18	14	20	1.99(kg)

歯幅、高さの仕上り寸法

素材の寸法公差は引き抜き材のために歯幅、高さ共に h11 ~ 12 級程度に仕上がっております。

全長について

ラックの両端面加工を施してあるものは、理論値から 0.06 ~ 0.5mm マイナスしています。

両端面加工 (連結用ピッチ合せ加工)

ラックを連結して使用する場合に両端面加工 *p* の寸法に仕上がっております。

経年変化について

歯切り加工後矯正を行っておりますが経年変化により曲がりが発生することがあります。

Surface condition and Tolerances of Face Width and Overall thickness.

Tolerances of Racks have been about h11 to h12 for Face width, Overall thickness are processed by cold drawn material.

Regarding to Overall Length of Racks.

Both ends processed of Racks had an overall length of theory tolerance that range from minus 0.06 to 0.5 mm.

Both ends processed Racks (Counterpart process for the joining.)

Please refer to dimension of P for the rack joining.

Regarding to the Secular change.

Due to the characteristic of materials, secular change or cause of inter-stress may result in the possibility that the straightness of dimension may change after the adjustment of the racks.

取付穴付 SUS ラック

RACKS(SUS)with fixed holes and both ends processed

モジュール **1.5/2**
MODULE

圧力角 20° (並歯)

20° PRESSURE ANGLE FULL DEPTH TOOTH



御注文には必ず“フルネームで商品記号”を明記してください。
Please refer to the catalogue reference while ordering.

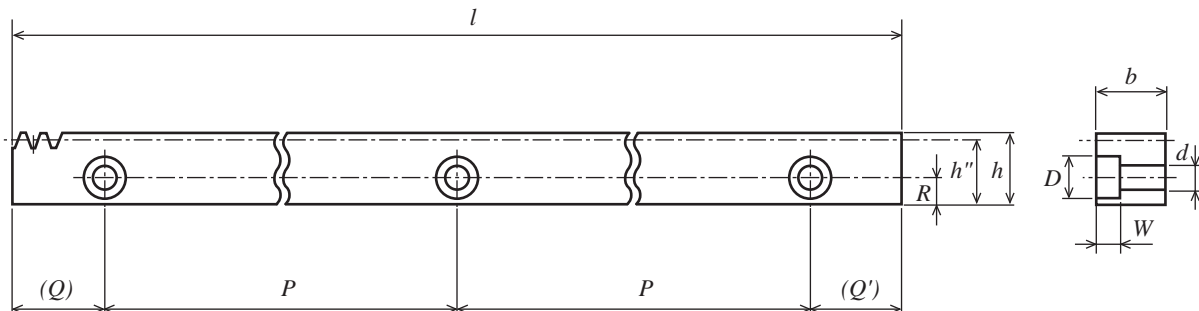

取付穴付ラック
KG-Rack with fixed holes

SUS304 ステンレス鋼 (JIS G 4303)
Material : Stainless Steel SUS304 (JIS G 4318)

単位 : mm
Dimensions : mm

モジュール Module m	商品記号 Catalogue Number	全長 Overall Length l	かみ合い 高さ Datum Line h''	歯幅 Face Width b(h12)	高さ Overall Thickness h(h12)	取付穴								重量 Weight W(kg)
						穴数	キリ穴 Drill Hole Diameter d	ザクリ 径 Counter Sink Diameter D	ザクリ 深さ Counter Sink Depth W	底面から の高さ R	端面位置		ピッチ P	
											(Q)	(Q')		
1.5	RK1.5SU 3 - 1219M	301.59	17.5	12	19	3	5.5	9.5	5.4	7	20.8	20.8	130	0.48
1.5	RK1.5SU 5 - 1219M	499.51	17.5	12	19	4	5.5	9.5	5.4	7	24.7	24.7	150	0.80
1.5	RK1.5SU 10 - 1219M	1008.45	17.5	12	19	6	5.5	9.5	5.4	7	49.5	58.9	180	1.63
1.5	RK1.5SU 3 - 1616M	301.59	14.5	16	16	3	5.5	9.5	5.4	6	20.8	20.8	130	0.53
1.5	RK1.5SU 5 - 1616M	499.51	14.5	16	16	4	5.5	9.5	5.4	6	24.7	24.7	150	0.88
1.5	RK1.5SU 10 - 1616M	1008.45	14.5	16	16	6	5.5	9.5	5.4	6	49.5	58.9	180	1.79
2	RK2SU 3 - 1420M	301.59	18	14	20	3	6.6	11	6.5	7	20.8	20.8	130	0.57
2	RK2SU 5 - 1420M	496.37	18	14	20	4	6.6	11	6.5	7	23.1	23.1	150	0.95
2	RK2SU 10 - 1420M	1005.31	18	14	20	6	6.6	11	6.5	7	52.6	52.6	180	1.94

全長について

ラックの両端面加工を施してあるものは、理論値から 0.06 ~ 0.5mm マイナスしています。

両端面加工 (連結用ピッチ合せ加工)

ラックを連結して使用する場合に両端面加工 p の寸法に仕上がっております。

Regarding to Overall Length of Racks.

Both ends processed of Racks had an overall length of theory tolerance that range from minus 0.06 to 0.5 mm.

Both ends processed Racks (Counterpart process for the joining.)

Please refer to dimension of P for the rack joining.

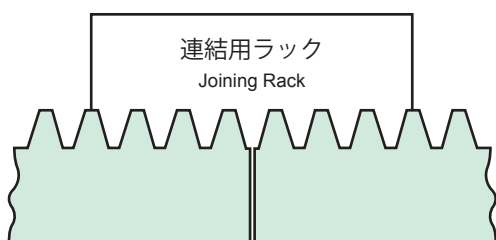

ラック連結例
Example of Joining Racks

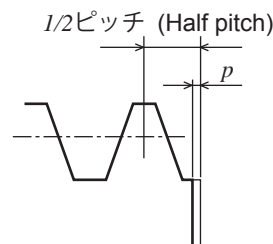

ラック端面加工形状
Detail of both ends processed Racks

目次 CONTENTS

インフォメーション INFORMATION

ギヤボックス GEAR BOXES

ノーバッキングギヤ ANTI BACKLASH SPUR GEARS

歯研削歯車 GROUND SPUR GEARS

平歯車 SPUR GEARS

内歯車 INTERNAL GEARS

歯研削ラック GROUND RACKS

ラック RACKS

へリカル・スクリューギヤ HELICAL GEARS AND SCREW GEARS

ワーム・ワームホイール WORMS AND WORM WHEELS

かさ歯車 BEVEL GEARS

スプロケット SPROCKETS

技術資料 REFERENCE DATA

S45C ラック RACKS

モジュール 1/1.25/1.5/2 圧力角 20° (並歯)
MODULE 20° PRESSURE ANGLE FULL DEPTH TOOTH



S45C 機械構造用炭素鋼 (JIS G 4051) Material : Carbon Steel

単位 : mm
Dimensions : mm

モジュール Module <i>m</i>	商品記号 Catalogue Number	全長 Overall Length <i>l</i>	両端面加工 Both Ends Processed <i>p</i>	有効歯数 Effective Number of Teeth <i>z</i>	かみ合い高さ Datum Line <i>h''</i>	歯幅 Face Width <i>b(h12)</i>	高さ Overall Thickness <i>h(h12)</i>	重量 Weight <i>W(kg)</i>
1	RK1SD 3 - 1010	303 ~ 306	-	94	9	10	10	0.20
1	RK1SD 5 - 1010	505 ~ 508	-	158	9	10	10	0.34
1	RK1SD 10 - 1015	1021.0	0.03 ~ 0.12	325	14	10	15	1.12
1.25	RK1.25SD 5 - 1010	505 ~ 508	-	126	8.75	10	10	0.34
1.25	RK1.25SD 5 - 1313	505 ~ 508	-	126	11.75	13	13	0.60
1.5	RK1.5SD 3 - 1616	303 ~ 306	-	62	14.5	16	16	0.53
1.5	RK1.5SD 5 - 1216	505 ~ 508	-	105	14.5	12	16	0.66
1.5	RK1.5SD 5 - 1616	503 ~ 506	-	105	14.5	16	16	0.90
1.5	RK1.5SD 10 - 1616	1008.5	0.06 ~ 0.18	214	14.5	16	16	1.84
1.5	RK1.5SD 5 - 1620	503 ~ 506	-	105	18.5	16	20	1.16
1.5	RK1.5SD 10 - 1620	1008.5	0.06 ~ 0.18	214	18.5	16	20	2.34
1.5	RK1.5SD 16 - 1620	1602.2	0.06 ~ 0.18	340	18.5	16	20	3.72
2	RK2SD 3 - 2020	303 ~ 306	-	46	18	20	20	0.90
2	RK2SD 5 - 2020	503 ~ 506	-	78	18	20	20	1.40
2	RK2SD 10 - 1420	1005.3	0.06 ~ 0.18	160	18	14	20	1.95
2	RK2SD 10 - 2020	1005.3	0.06 ~ 0.18	160	18	20	20	2.80
2	RK2SD 5 - 2025	501 ~ 506	-	78	23	20	25	1.80
2	RK2SD 10 - 2025	1005.3	0.06 ~ 0.18	160	23	20	25	3.63
2	RK2SD 16 - 2025	1602.2	0.06 ~ 0.18	255	23	20	25	5.80

歯幅、高さの仕上り寸法

素材の寸法公差は引き抜き材のために歯幅、高さ共に h11 ~ 12 級程度に仕上がっております。

経年変化について

歯切り加工後矯正を行っておりますが経年変化により曲がりが発生することがあります。

高周波焼入れ

S45C のラック素材は引き抜き材のため表面に脱炭層があり、歯部高周波焼入れをした場合に表面の硬度が上がらないことがあります。また、歪、曲がりが発生しピッチの変化の原因となりますのでご注意ください。

Surface condition and Tolerance of Face Width and Overall thickness.

Tolerances of Racks have been about h11 to h12 for Face width, Overall Thickness are processed by cold drawn material.

Regarding to the Secular change.

Due to the characteristic of materials, secular change or cause of inter-stress may result in the possibility that the straightness of dimension may change after the adjustment of the racks.

The Quenching.

Due to cold drawn of S45C material's Rack, it has a layer of decarburization. Additional heat treatment on the teeth of cold drawn Racks are not recommended due to possibility to obtain quenching cracks and unfulfilled quenching temperature. It will also affect the pitch of the Rack and straightness due to the cause of strain and bending

取付穴付き S45C ラック

RACKS(S45C)with fixed holes and both ends processed

モジュール 1/1.5/2

MODULE

圧力角 20° (並歯)

20° PRESSURE ANGLE FULL DEPTH TOOTH



御注文には必ず“フルネームで商品記号”を明記してください。

Please refer to the catalogue reference while ordering.

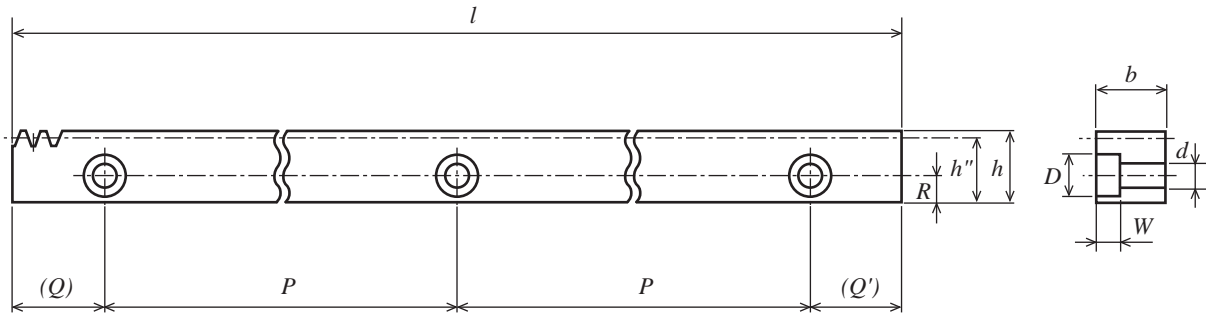

取付穴付ラック
KG-Rack with fixed holes

S45C 機械構造用炭素鋼 (JIS G 4051)

Material : Carbon Steel

単位 : mm
Dimensions : mm

モジュール Module <i>m</i>	商品記号 Catalogue Number	全長 Overall Length <i>l</i>	かみ合い 高さ Datum Line <i>h''</i>	歯幅 Face Width <i>b(h12)</i>	高さ Overall Thickness <i>h(h12)</i>	取付穴							重量 Weight <i>W(kg)</i>	
						穴数	キリ穴 Drill Hole Diameter <i>d</i>	ザクリ 径 Counter Sink Diameter <i>D</i>	ザクリ 深さ Counter Sink Depth <i>W</i>	底面から の高さ <i>R</i>	端面位置			ピッチ <i>P</i>
											<i>(Q)</i>	<i>(Q')</i>		
1	RK1SD 3 - 1015M	298.45	14	10	15	3	4.5	—	—	6	19.2	19.2	130	0.32
1	RK1SD 5 - 1015M	505.79	14	10	15	4	4.5	—	—	6	27.9	27.9	150	0.55
1	RK1SD 10 - 1015M	1021.01	14	10	15	6	4.5	—	—	6	60.5	60.5	180	1.11
1.5	RK1.5SD 3 - 1616M	301.59	14.5	16	16	3	5.5	9.5	5.4	6	20.8	20.8	130	0.53
1.5	RK1.5SD 5 - 1616M	499.51	14.5	16	16	4	5.5	9.5	5.4	6	24.7	24.7	150	0.88
1.5	RK1.5SD 10 - 1616M	1008.45	14.5	16	16	6	5.5	9.5	5.4	6	49.5	58.9	180	1.80
1.5	RK1.5SD 3 - 1620M	301.59	18.5	16	20	3	5.5	9.5	5.4	8	20.8	20.8	130	0.68
1.5	RK1.5SD 5 - 1620M	499.51	18.5	16	20	4	5.5	9.5	5.4	8	24.7	24.7	150	1.13
1.5	RK1.5SD 10 - 1620M	1008.45	18.5	16	20	6	5.5	9.5	5.4	8	49.5	58.9	180	2.30
2	RK2SD 3 - 1420M	301.59	18	14	20	3	6.6	11	6.5	7	20.8	20.8	130	0.57
2	RK2SD 5 - 1420M	496.37	18	14	20	4	6.6	11	6.5	7	23.1	23.1	150	0.95
2	RK2SD 10 - 1420M	1005.31	18	14	20	6	6.6	11	6.5	7	52.6	52.6	180	1.94
2	RK2SD 3 - 2020M	301.59	18	20	20	3	6.6	11	6.5	7	20.8	20.8	130	0.82
2	RK2SD 5 - 2020M	496.37	18	20	20	4	6.6	11	6.5	7	23.1	23.1	150	1.36
2	RK2SD 10 - 2020M	1005.31	18	20	20	6	6.6	11	6.5	7	52.6	52.6	180	2.77
2	RK2SD 3 - 2025M	301.59	23	20	25	3	6.6	11	6.5	10	20.8	20.8	130	1.05
2	RK2SD 5 - 2025M	496.37	23	20	25	4	6.6	11	6.5	10	23.1	23.1	150	1.75
2	RK2SD 10 - 2025M	1005.31	23	20	25	6	6.6	11	6.5	10	52.6	52.6	180	3.56

目次
CONTENTS

インフォメーション
INFORMATION

ギヤボックス
GEAR BOXES

ノーバッキングギヤ
ANTI BACKLASH SPUR GEARS

歯研削歯
GROUND SPUR GEARS

平歯車
SPUR GEARS

内歯車
INTERNAL GEARS

歯ラック
GROUND RACKS

ラック
RACKS

へリカル・スクリューギヤ
HELICAL GEARS AND SCREW GEARS

ワームとワームホイール
WORMS AND WORM WHEELS

かさ歯車
BEVEL GEARS

スプロケット
SPROCKETS

技術資料
REFERENCE DATA

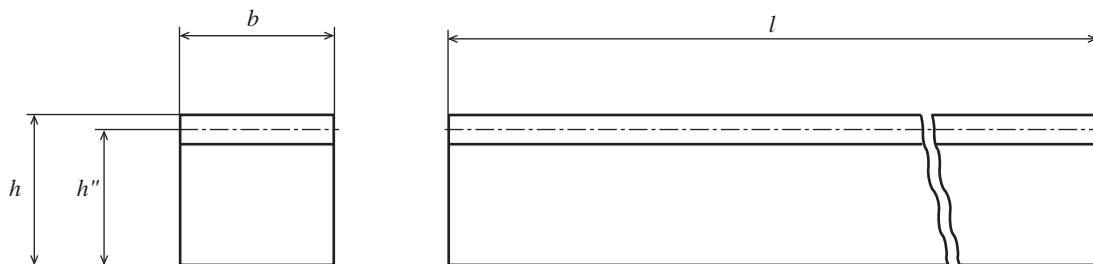

S45C 機械構造用炭素鋼 (JIS G 4051)

Material : Carbon Steel

単位 : mm
Dimensions : mm

モジュール Module <i>m</i>	商品記号 Catalogue Number	全長 Overall Length <i>l</i>	両端面加工 Both Ends Processed <i>p</i>	有効歯数 Effective Number of Teeth <i>z</i>	かみ合い高さ Datum Line <i>h''</i>	歯幅 Face Width <i>b(h12)</i>	高さ Overall Thickness <i>h(h12)</i>	重量 Weight <i>W(kg)</i>
2.5	RK2.5SD 3 - 2525	303 ~ 306	-	36	22.5	25	25	1.32
2.5	RK2.5SD 5 - 2525	503 ~ 506	-	62	22.5	25	25	2.20
2.5	RK2.5SD 10 - 1825	1005.3	0.06 ~ 0.18	128	22.5	18	25	3.13
2.5	RK2.5SD 10 - 2525	1005.3	0.06 ~ 0.18	128	22.5	25	25	4.40
2.5	RK2.5SD 5 - 2530	501 ~ 506	-	62	27.5	25	30	2.69
2.5	RK2.5SD 10 - 2530	1005.3	0.06 ~ 0.18	128	27.5	25	30	5.42
2.5	RK2.5SD 16 - 2530	1602.2	0.06 ~ 0.18	204	27.5	25	30	8.60
3	RK3SD 3 - 3030	300 ~ 306	-	30	27	30	30	1.90
3	RK3SD 5 - 3030	503 ~ 506	-	52	27	30	30	3.20
3	RK3SD 10 - 2230	1008.5	0.10 ~ 0.25	107	27	22	30	4.80
3	RK3SD 10 - 3030	1008.5	0.10 ~ 0.25	107	27	30	30	6.40
3	RK3SD 5 - 3035	501 ~ 506	-	52	32	30	35	3.76
3	RK3SD 10 - 3035	1008.5	0.10 ~ 0.25	107	32	30	35	7.60
3	RK3SD 16 - 3035	1602.2	0.10 ~ 0.25	170	32	30	35	12.10
4	RK4SD 10 - 4040	1005.3	0.10 ~ 0.25	80	36	40	40	12.00
5	RK5SD 10 - 5050	1005.3	0.10 ~ 0.25	64	45	50	50	18.50

全長について

ラックの両端面加工を施してあるものは、理論値から 0.06 ~ 0.5mm マイナスしています。

両端面加工 (連結用ピッチ合せ加工)

ラックを連結して使用する場合に両端面加工 *p* の寸法に仕上がっております。

Regarding to Overall Length of Racks.

Both ends processed of Racks had an overall length of theory tolerance that range from minus 0.06 to 0.5 mm.

Both ends processed Racks (Counterpart process for the joining.)

Please refer to dimension of *P* for the rack joining.

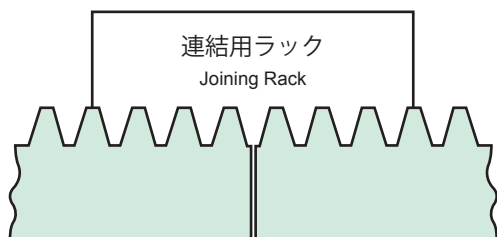

ラック連結例
Example of Joining Racks

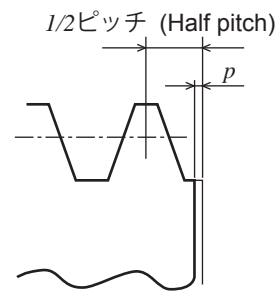

ラック端面加工形状
Detail of both ends processed Racks

取付穴付き S45C ラック

RACKS(S45C)with fixed holes and both ends processed

モジュール **2.5/3**
MODULE

圧力角 20° (並歯)

20° PRESSURE ANGLE FULL DEPTH TOOTH



御注文には必ず“フルネームで商品記号”を明記してください。
Please refer to the catalogue reference while ordering.

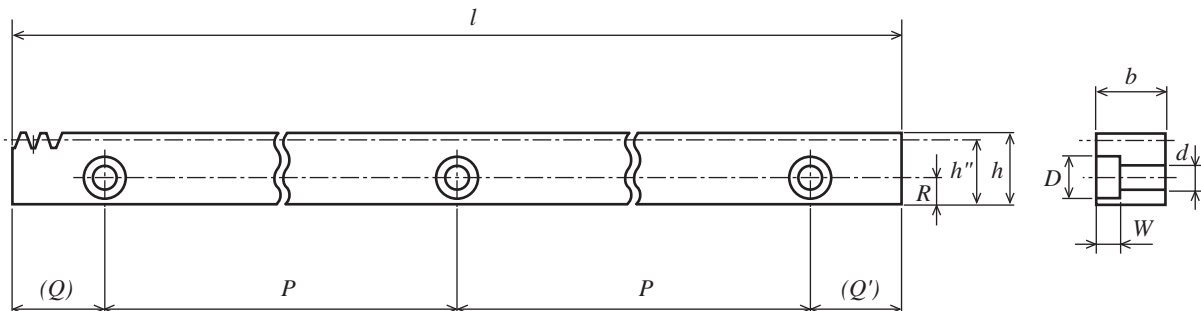

取付穴付ラック
KG-Rack with fixed holes

S45C 機械構造用炭素鋼 (JIS G 4051)

Material : Carbon Steel

単位 : mm
Dimensions : mm

モジュール Module <i>m</i>	商品記号 Catalogue Number	全長 Overall Length <i>l</i>	かみ合い 高さ Datum Line <i>h''</i>	歯幅 Face Width <i>b(h12)</i>	高さ Overall Thickness <i>h(h12)</i>	取付穴								重量 Weight <i>W(kg)</i>
						穴数	キリ穴 Drill Hole Diameter <i>d</i>	ザクリ 径 Counter Sink Diameter <i>D</i>	ザクリ 深さ Counter Sink Depth <i>W</i>	底面から の高さ <i>R</i>	端面位置		ピッチ <i>P</i>	
											<i>(Q)</i>	<i>(Q')</i>		
2.5	RK2.5SD 3 - 1825M	298.45	22.5	18	25	3	9	14	8.6	9	19.2	19.2	130	0.90
2.5	RK2.5SD 5 - 1825M	494.80	22.5	18	25	4	9	14	8.6	9	22.4	22.4	150	1.51
2.5	RK2.5SD 10 - 1825M	1005.31	22.5	18	25	6	9	14	8.6	9	52.6	52.6	180	3.10
2.5	RK2.5SD 3 - 2525M	298.45	22.5	25	25	3	9	14	8.6	9	19.2	19.2	130	1.24
2.5	RK2.5SD 5 - 2525M	494.80	22.5	25	25	4	9	14	8.6	9	22.4	22.4	150	2.09
2.5	RK2.5SD 10 - 2525M	1005.31	22.5	25	25	6	9	14	8.6	9	52.6	52.6	180	4.29
2.5	RK2.5SD 3 - 2530M	298.45	27.5	25	30	3	9	14	8.6	12	19.2	19.2	130	1.54
2.5	RK2.5SD 5 - 2530M	494.80	27.5	25	30	4	9	14	8.6	12	22.4	22.4	150	2.57
2.5	RK2.5SD 10 - 2530M	1005.31	27.5	25	30	6	9	14	8.6	12	52.6	52.6	180	5.28
3	RK3SD 3 - 2230M	301.59	27	22	30	3	11	17.5	10.8	11	20.8	20.8	130	1.32
3	RK3SD 5 - 2230M	499.51	27	22	30	4	11	17.5	10.8	11	24.7	24.7	150	2.21
3	RK3SD 10 - 2230M	1008.45	27	22	30	6	11	17.5	10.8	11	49.5	58.9	180	4.53
3	RK3SD 3 - 3030M	301.59	27	30	30	3	11	17.5	10.8	11	20.8	20.8	130	1.78
3	RK3SD 5 - 3030M	499.51	27	30	30	4	11	17.5	10.8	11	24.7	24.7	150	3.00
3	RK3SD 10 - 3030M	1008.45	27	30	30	6	11	17.5	10.8	11	49.5	58.9	180	6.15
3	RK3SD 3 - 3035M	301.59	32	30	35	3	11	17.5	10.8	14	20.8	20.8	130	2.14
3	RK3SD 5 - 3035M	499.51	32	30	35	4	11	17.5	10.8	14	24.7	24.7	150	3.59
3	RK3SD 10 - 3035M	1008.45	32	30	35	6	11	17.5	10.8	14	49.5	58.9	180	7.33

目次 CONTENTS

インフォメーション INFORMATION

ギヤボックス GEAR BOXES

ノーバッキングギヤ ANTI BACKLASH SPUR GEARS

歯研研歯 GROUND SPUR GEARS

平歯車 SPUR GEARS

内歯車 INTERNAL GEARS

歯ラック GROUND RACKS

ラック RACKS

へリカル・スクリューギヤ HELICAL GEARS AND SCREW GEARS

ワーム・マニマニギヤ WORMS AND WORM WHEELS

かさ歯車 BEVEL GEARS

スプロケット SPROCKETS

技術データ REFERENCE DATA

CP (サーキュラーピッチ) ラック

CIRCULAR PITCH RACKS

ピッチ **2/5/10** 圧力角 20° (並歯)
 PITCH **2/5/10** 20° PRESSURE ANGLE FULL DEPTH TOOTH

目次
CONTENTS

インフォメーション
INFORMATION

ギヤボックス
GEAR BOXES

ノーバクラッシュギヤ
ANTI BACKLASH SPUR GEARS

歯車
GROUND SPUR GEARS

平歯車
SPUR GEARS

内歯車
INTERNAL GEARS

歯車ラック
GROUND RACKS

ラック
RACKS

ヘリカルスクリューギヤ
HELICAL GEARS AND SCREW GEARS

ウォーム
WORMS AND WORM WHEELS

かさ歯車
BEVEL GEARS

スプロケット
SPURKETS

技術資料
REFERENCE DATA



御注文には必ず“フルネームで商品記号”を明記してください。
 Please refer to the catalogue reference while ordering.

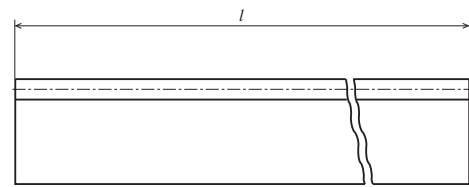
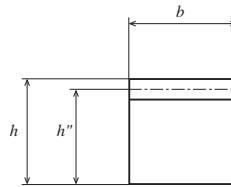
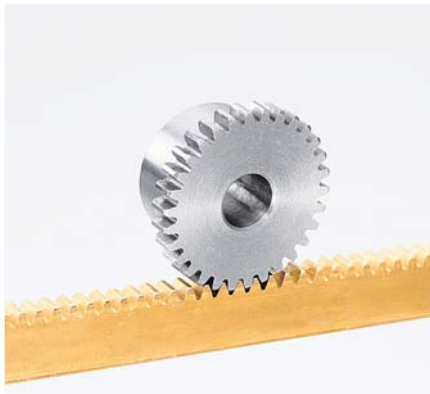

サーキュラーピッチラック

Material : Brass , Carbon Steel

単位 : mm
 Dimensions : mm

ピッチ Circular Pitch <i>cp</i>	商品記号 Catalogue Number	材質 Material <i>M</i>	全長 Overall Length <i>l</i>	両端面加工 Both Ends Processed <i>p</i>	有効歯数 Effective Number of Teeth <i>z</i>	かみ合い高さ Datum Line <i>h''</i>	歯幅 Face Width <i>b(h1l)</i>	高さ Overall Thickness <i>h(h1l)</i>	重量 Weight <i>W(g)</i>
2	RKP2B 2 - 0308	C3604B	200	-	98	7.36	3	8	35.8
2	RKP2B 5 - 0310	C3604B	500	-	248	9.36	3	10	113.7
5	RKP5SD 5 - 1616	S45C	503 ~ 506	-	98	14.41	16	16	0.92(kg)
5	RKP5SD 10 - 1616	S45C	1,000	0.06 ~ 0.18	200	14.41	16	16	1.80(kg)
10	RKP10SD 5 - 3030	S45C	503 ~ 506	-	48	26.82	30	30	3.16(kg)
10	RKP10SD 10 - 3030	S45C	1,000	0.10 ~ 0.25	100	26.82	30	30	6.32(kg)

注) CP ラックとは モジュールラックは一歯当りピッチは $\pi \cdot m$ (モジュール) ですが、CP ラック・ピニオンの組合せは、ピニオン 1 回当り・ラック移動量を、100、150、200、... というような決めることができます。したがって、ステッピング・モーター、サーボ・モーター等との組合せによる設計が容易になります。ボールネジ等高価な部品を使う前に一度ご検討下さい。

注) CP ラックは CP ピニオンとのみかみ合います。同じピッチのラックとピニオンを組合せて下さい。モジュールサイズのピニオンとはかみ合いません。

Note that engagement of CP-Racks and Pinions has been design to obtain a traveling distance of one full turn of a pinion on the CP Racks at an integer figure (e.g. 100, 150 or 200...), but instead the Module Rack has been design at one pitch with $\pi \cdot m$ (about 3.14159 mm x Module). Therefore it is easier to design CP Rack & Pinion with Servo and Stepping motors. Please consider designing the CP-Racks and Pinions before using a costly of ball screw.

Note that engagement of the same pitches of CP-Rack and Pinions are indispensable. CP-Rack and Module pinion are impossible.

RoHS 対応

2006 年 11 月生産開始分より欧州 RoHS 指令に対応できる商品を提供しています。
 We supplied the KG-products with RoHS compliance of EU to all our valued customers since November 2006

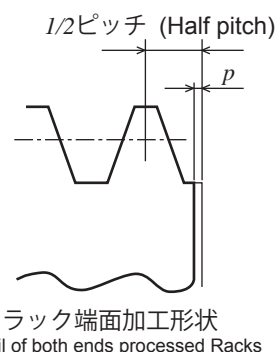
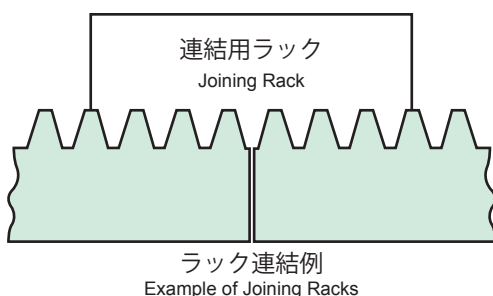



New **ねじを2箇所 (120°配) にしました。**
締結力が1.6倍になりました。
 New item with two threaded holes (120°)
 Tightening power increased by 1.6 times.

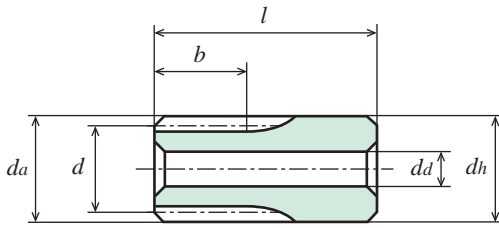

K2形
TYPE K2

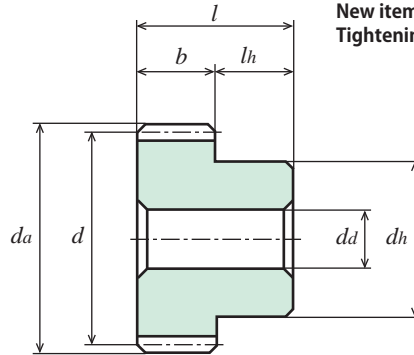

B1形
TYPE B1

S45C 機械構造用炭素鋼 (JIS G 4051)

Material : Brass Carbon Steel

単位 : mm
Dimensions : mm

ピッチ Circular Pitch <i>cp</i>	商品記号 Catalogue Number	歯数 Number of Teeth <i>z</i>	基準円直径 Reference Diameter <i>d</i>	歯先円直径 Tip Diameter <i>da</i>	形 Type	歯幅 Face Width <i>b</i>	穴径 Bore Diameter <i>da(H7)</i>	ハブ外径 Hub Diameter <i>dh</i>	ハブ長さ Hub Projection <i>lh</i>	全長 Overall Length <i>l</i>	ねじ Set Screw		1回転距離 Distance of one turn <small>注)</small>	重量 Weight <i>W(g)</i>
											2-M(120°)	<i>ls</i>		
2	SP2S - 15	15	φ 9.55	φ 10.82	K2	5	φ4(H8)	φ10.82	10	15	-	-	30	8.54
2	SP2S * 15	15	φ 9.55	φ 10.82	K2	5	φ4(H8)	φ10.82	10	15	2-M3	3	30	8.25
2	SP2S - 20	20	φ12.73	φ 14.01	B1	3	φ 5	φ10	7	10	-	-	40	5.78
2	SP2S * 20	20	φ12.73	φ 14.01	B1	3	φ 5	φ10	7	10	2-M3	3.5	40	5.55
2	SP2S - 25	25	φ15.92	φ 17.19	B1	3	φ 6	φ12	7	10	-	-	50	8.67
2	SP2S * 25	25	φ15.92	φ 17.19	B1	3	φ 6	φ12	7	10	2-M3	3.5	50	8.42
2	SP2S - 30	30	φ19.10	φ 20.37	B1	3	φ 6	φ15	7	10	-	-	60	14.2
2	SP2S * 30	30	φ19.10	φ 20.37	B1	3	φ 6	φ15	7	10	2-M4	3.5	60	13.5

注) 1回転移動距離・・・ピニオンがラック上で1回転した時に移動する距離です。

Travelling distance of one turn.

Obtain travelling amount of integral number, revolved one turn of the CP Pinion on the CP Rack.

【*】(アスタ)にはセットスクリーが2個付いております。

[*]: Gear with two threaded holes / with two set screws.

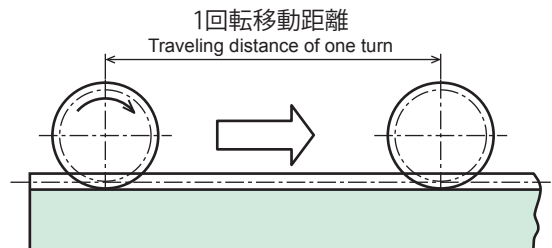

許容伝達動力表 曲げ強さ (W)

Allowable transfer capability table (W) Bending Strength

商品記号 Catalogue Numbers	回転速度 (min ⁻¹) revolution/min						
	10	100	200	400	800	1,200	1,500
SP2S - 15	0.88	8.78	17.55	35.10	70.21	105.31	131.64
SP2S - 20	0.83	8.25	16.50	33.00	66.01	99.01	117.89
SP2S - 25	1.14	11.36	22.71	45.43	90.86	131.38	154.87
SP2S - 30	1.46	14.56	29.12	58.25	116.49	162.56	189.99

The above references are JGMA standard.

動力の換算式は P26 をご参照ください。Please refer to the conversion fomulas of power on page P26.

許容伝達動力表 歯面強さ (W)

Allowable transfer capability table (W) Surface Durability

商品記号 Catalogue Numbers	回転速度 (min ⁻¹) revolution/min						
	10	100	200	400	800	1,200	1,500
SP2S - 15	0.03	0.29	0.59	1.21	2.42	3.63	4.54
SP2S - 20	0.03	0.33	0.66	1.32	2.63	3.95	4.81
SP2S - 25	0.05	0.53	1.05	2.10	4.27	6.19	7.34
SP2S - 30	0.08	0.77	1.55	3.10	6.27	8.76	10.41

CP ラックピニオン CIRCULAR PITCH PINIONS

ピッチ 5/10
PITCH

圧力角 20° (並歯)
20° PRESSURE ANGLE FULL DEPTH TOOTH

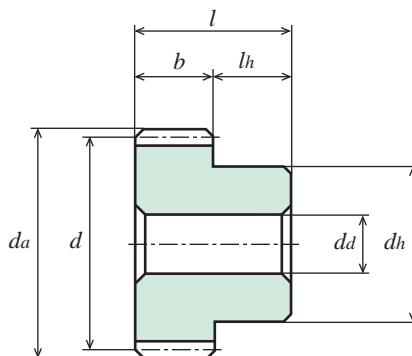

B1形
TYPE B1

S45C 機械構造用炭素鋼 (JIS G 4051)
Material : Brass Carbon Steel

単位 : mm
Dimensions : mm

ピッチ Circular Pitch <i>cp</i>	商品記号 Catalogue Number	歯数 Number of Teeth <i>z</i>	基準円直径 Reference Diameter <i>d</i>	歯先円直径 Tip Diameter <i>da</i>	形 Type	歯幅 Face Width <i>b</i>	穴径 Bore Diameter <i>da(H7)</i>	ハブ外径 Hub Diameter <i>dh</i>	ハブ長さ Hub Projection <i>lh</i>	全長 Overall Length <i>l</i>	ねじ Set Screw		1回転距離 Distance of one turn 注)	重量 Weight <i>W(g)</i>
											2-M(120°)	<i>ls</i>		
5	SP5S - 15	15	φ23.87	φ27.06	B1	16	φ8	φ18	10	26	-	-	75	65.9
5	SP5S - 16	16	φ25.46	φ28.65	B1	16	φ8	φ20	10	26	-	-	80	78.3
5	SP5S - 20	20	φ31.83	φ35.01	B1	16	φ10	φ25	10	26	-	-	100	122.4
5	SP5S - 24	24	φ38.20	φ41.38	B1	16	φ10	φ25	10	26	-	-	120	166.3
5	SP5S - 25	25	φ39.79	φ42.97	B1	16	φ10	φ25	10	26	-	-	125	178.6
5	SP5S - 30	30	φ47.75	φ50.93	B1	16	φ10	φ40	10	26	-	-	150	307.4
10	SP10S - 20	20	φ63.66	φ70.03	B1	30	φ18	φ50	15	45	-	-	200	0.89(kg)
10	SP10S - 25	25	φ79.58	φ85.94	B1	30	φ18	φ50	15	45	-	-	250	1.31(kg)
10	SP10S - 30	30	φ95.49	φ101.86	B1	30	φ18	φ60	15	45	-	-	300	1.93(kg)

注) 1回転移動距離・・・ピニオンがラック上で1回転した時に移動する距離です。

Travelling distance of one turn.

Obtain travelling amount of integral number, revolved one turn of the CP Pinion on the CP Rack.

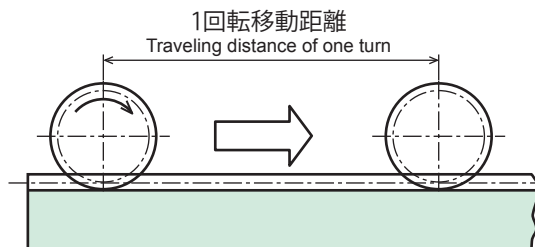

許容伝達動力表 曲げ強さ (W)

Allowable transfer capability table (W) Bending Strength

商品記号 Catalogue Numbers	回転速度 (min ⁻¹) revolution/min						
	10	100	200	400	800	1,200	1,500
SP5S - 15	17.55	175.51	351.03	702.06	1353.35	1861.80	2149.14
SP5S - 16	19.58	195.83	391.65	775.54	1491.99	2043.38	2349.95
SP5S - 20	27.51	275.13	550.27	1048.12	2000.97	2695.23	3134.46
SP5S - 24	35.75	357.55	715.09	1312.09	2487.24	3300.42	3972.78
SP5S - 25	37.86	378.59	752.47	1376.67	2605.30	3477.94	4180.66
SP5S - 30	48.54	485.44	935.79	1688.48	3170.25	4355.38	5201.23
SP10S - 20	206.4	2063.5	3751.8	6603.2	12537.7	17687.1	21265.0
SP10S - 25	283.9	2821.8	4885.0	8626.0	16722.8	23634.2	28394.0
SP10S - 30	364.1	3509.2	5944.2	10787.6	20804.7	29453.5	36408.2

The above references are JGMA standard.

動力の換算式は P26 をご参照ください。Please refer to the conversion formulas of power on page P26.

許容伝達動力表 歯面強さ (W)

Allowable transfer capability table (W) Surface Durability

商品記号 Catalogue Numbers	回転速度 (min ⁻¹) revolution/min						
	10	100	200	400	800	1,200	1,500
SP5S - 15	0.65	6.55	13.21	26.63	51.62	71.99	84.51
SP5S - 16	0.75	7.51	15.13	30.23	58.53	81.28	95.19
SP5S - 20	1.20	12.03	24.28	46.78	89.93	123.79	147.26
SP5S - 24	1.76	17.69	35.76	66.51	127.17	173.46	213.09
SP5S - 25	1.91	19.28	38.77	71.92	137.43	188.73	232.18
SP5S - 30	2.81	28.36	55.43	101.68	193.54	275.03	339.52
SP10S - 20	9.67	97.83	181.2	327.2	632.5	932.7	1169.8
SP10S - 25	15.5	156.2	276.8	505.6	997.5	1496.5	1875.6
SP10S - 30	22.78	223.3	389.8	732.0	1458.7	2192.2	2850.5

Memo

目次
CONTENTS

インフォメーション
INFORMATION

ギヤボックス
GEAR BOXES

ノーバッキングギヤ
ANTI BACKLASH SPUR GEARS

歯研平歯
GROUND SPUR GEARS

平歯
SPUR GEARS

内歯
INTERNAL GEARS

歯ラック
GROUND RACKS

ラック
RACKS

へりかき・スクリューギヤ
HELICAL GEARS AND SCREW GEARS

ワーム・ワームホイール
WORMS AND WORM WHEELS

かみ歯
BEVEL GEARS

スプロケット
SPROCKETS

技術資料
REFERENCE DATA

Memo

目次
CONTENTS

インフォメーション
INFORMATION

ギヤボックス
GEAR BOXES

ノーバックラッシュギヤ
ANTI BACKLASH SPUR GEARS

歯研平歯車
GROUND SPUR GEARS

平歯車
SPUR GEARS

内歯車
INTERNAL GEARS

歯研ラック
GROUND RACKS

ラック
RACKS

ヘリカル・スクリューギヤ
HELICAL GEARS AND SCREW GEARS

ウォーム・ウォームホイール
WORMS AND WORM WHEELS

かさ歯車
BEVEL GEARS

スプロケット
SPUR METS

技術資料
REFERENCE DATA



はすば歯車 ねじ歯車

Helical Gears and Screw Gears

商品記号の読み方 Reference of Catalogue Number

ヘリカル・ギヤ (はすば歯車)

H 1 S 13 R - B
H 1 SU 13 R - B
H 1 D 13 L * B

歯車の種類 Kind of Gear	モジュール Module	材質 Material	歯数 Number of Teeth	ねじれ方向 Direction of Helix	穴仕上 Bores Processed	形状 Type
Helical gear (ヘリカル) Helical gears and Screw gears	m : 1.0 1.5 2.0 2.5 3.0	S : S45C Carbon Steel SU : ステンレス (SUS304) Stainless Steel D : ポリアセタール Poly Acetal (Machined)	z : 13 26	R : 右ねじれ Right Hand L : 左ねじれ Left Hand	【-】旋削加工 Gear without Key Way / without Thread hole. 【*】: ネジ穴付 旋削仕上げ Gear with two threaded holes / with two set screws.	B : 片ハブ付き with Hub on one side.

Memo

目次
CONTENTS

インフォメーション
INFORMATION

ギヤボックス
GEAR BOXES

ノーバッキングスピリギヤ
ANTI BACKLASH SPIR GEARS

歯研平歯車
GROUND SPUR GEARS

平歯車
SPUR GEARS

内歯車
INTERNAL GEARS

歯研ラック
GROUND RACKS

ラック
RACKS

ヘリカル・スクリューギヤ
HELICAL GEARS AND SCREW GEARS

ウォーム・ウォームホイール
WORMS AND WORM WHEELS

かさ歯車
BEVEL GEARS

スプロケット
SPURKETS

技術資料
REFERENCE DATA

はすば歯車の使用上の注意

Usage precaution of Helical Gear

- 理想的な噛み合いをさせる為に、それぞれのねじ歯車の軸角 90 度はできるだけ正確に取りつけて下さい。
- ご使用の際、軸方向のスラストを生じますので軸方向スラストを十分耐えうる軸受にして下さい。
- はすば歯車のスラスト荷重について
はすば歯車は平歯車に比較して、噛み合いがなめらかなる長所がありますが、歯すじがねじれている為に軸方向のスラストを生じる欠点があります。したがって、軸方向スラストを十分支えるように軸受の設計をして下さい。

- To obtain ideal engagement of the shafts of Helical gears, provide right angle (90°) correctly.
- Provide the bearing that will completely support the thrust load when Helical gear is operated as the axial thrust direction.
- As for the thrust load of Helical gear.
Helical gear is able to obtain a smooth engagement compare to Spur gear, However Helical gear produces thrust load by helix angle on the tooth trace. Therefore the design of the shafts between drive gear (Pinion) and driven gear (Gear) should be in firm condition, and provide bearing that completely support pinion and gear against the axial thrust load.

はすば歯車の軸方向にかかるスラスト

Axial thrust load of helical gear and location of bearing

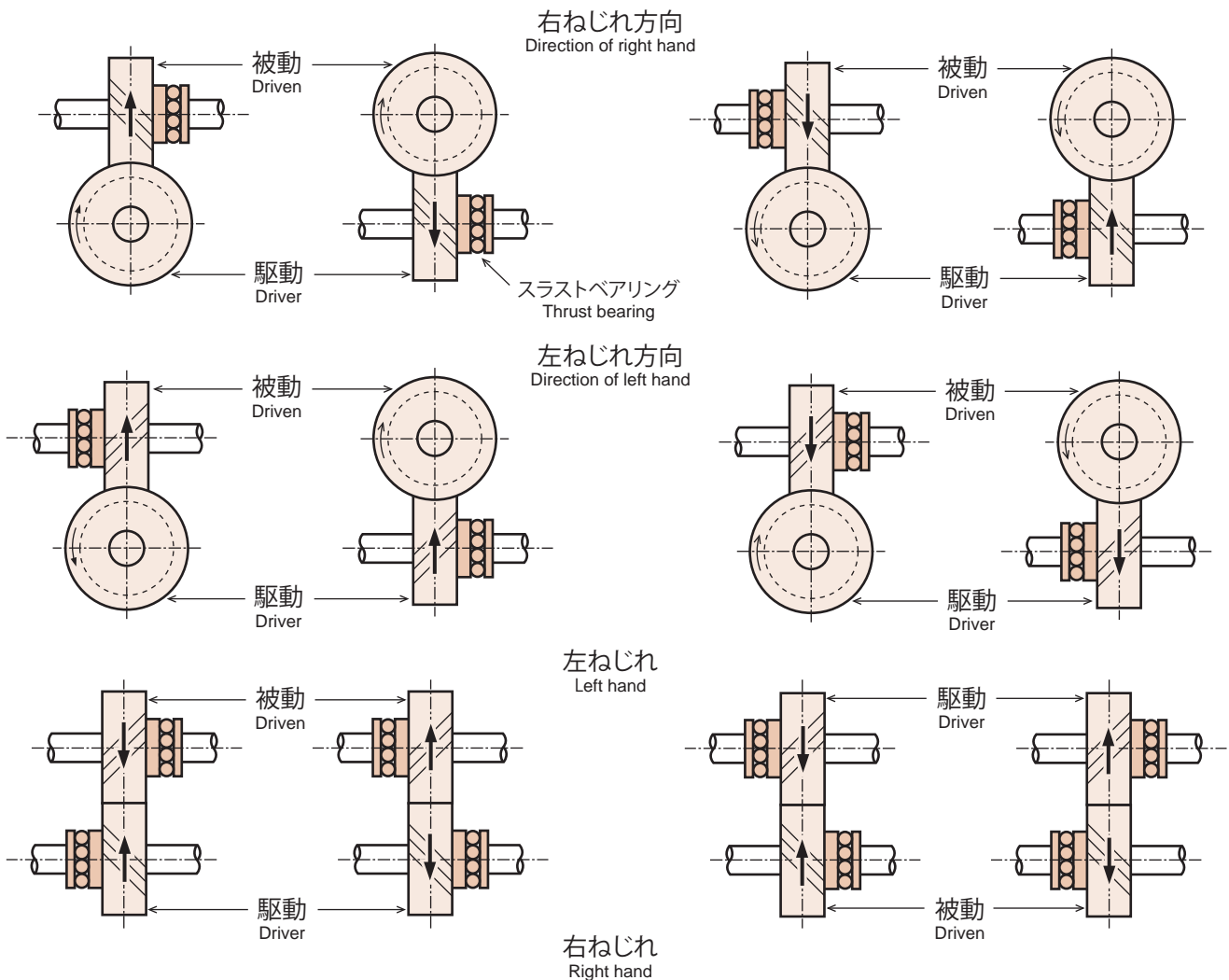

相手歯車を弊社以外の商品と組合わせて使用されますと、不具合が発生するおそれがあります。

KG STOCK GEARS 以外の仕様で設計される時は弊社までご相談ください。

KG-Helical gear is able to match with other gear makers however it is advisable to use KG-Gear for best result.

We are able to fabricate made to order according to your specifications. Please do not hesitate to contact us.

はすば歯車 / ねじ歯車

HELICAL GEARS

モジュール **1/1.5** 圧力角 20° (並歯) ねじれ角 45°
 20° PRESSURE ANGLE FULL DEPTH TOOTH 45° Helix Angle

JIS B 1702-1 (ISO) 9~10 級
 System of accuracy : JIS B 1702-1(ISO) class 9-10



New **ねじを2箇所 (120°配) にしました。**
 New item with two threaded holes (120°)

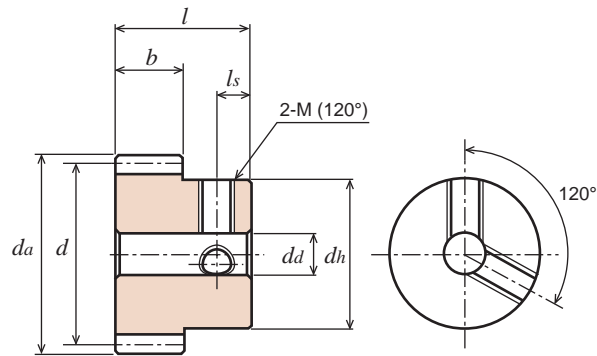

B1形
TYPE B1

ポリアセタール (白色)
 Material : Poly Acetal (White)

単位 : mm
 Dimensions : mm

商品記号 Catalogue Number	ねじれ方向 Direction of Helix	モジュール Module	歯数 Number of Teeth	基準円直径 Reference Diameter	歯先円直径 Tip Diameter	歯幅 Face Width	穴径 Bore Diameter	ハブ外径 Hub Diameter	ハブ長さ Hub Projection	全長 Overall Length	ねじ Set Screw		重量 Weight
											2-M(120°)	ls	
H1D 13R - B	R	1	13	φ18.38	φ20.4	12	φ 8	φ15	10	22	-	-	5.4
H1D 13L - B	L	1	13	φ18.38	φ20.4	12	φ 8	φ15	10	22	-	-	5.4
H1D 26R - B	R	1	26	φ36.77	φ38.8	12	φ10	φ32	10	22	-	-	26.9
H1D 26L - B	L	1	26	φ36.77	φ38.8	12	φ10	φ32	10	22	-	-	26.9
H1D 13R * B	R	1	13	φ18.38	φ20.4	12	φ 8	φ15	10	22	2-M3	5	5.3
H1D 13L * B	L	1	13	φ18.38	φ20.4	12	φ 8	φ15	10	22	2-M3	5	5.3
H1D 26R * B	R	1	26	φ36.77	φ38.8	12	φ10	φ32	10	22	2-M4	5	26.6
H1D 26L * B	L	1	26	φ36.77	φ38.8	12	φ10	φ32	10	22	2-M4	5	26.6
H1.5D 13R - B	R	1.5	13	φ27.58	φ30.6	15	φ10	φ23	10	25	-	-	15.7
H1.5D 13L - B	L	1.5	13	φ27.58	φ30.6	15	φ10	φ23	10	25	-	-	15.7
H1.5D 26R - B	R	1.5	26	φ55.15	φ58.2	15	φ12	φ40	10	25	-	-	64.2
H1.5D 26L - B	L	1.5	26	φ55.15	φ58.2	15	φ12	φ40	10	25	-	-	64.2
H1.5D 13R * B	R	1.5	13	φ27.58	φ30.6	15	φ10	φ23	10	25	2-M4	5	15.5
H1.5D 13L * B	L	1.5	13	φ27.58	φ30.6	15	φ10	φ23	10	25	2-M4	5	15.5
H1.5D 26R * B	R	1.5	26	φ55.15	φ58.2	15	φ12	φ40	10	25	2-M5	5	63.6
H1.5D 26L * B	L	1.5	26	φ55.15	φ58.2	15	φ12	φ40	10	25	2-M5	5	63.6

【*】(アスタ)にはセットスクリーが2個付いております。[*]: Gear with two threaded holes / with two set screws.

はすば歯車 (軸平行) 許容伝達動力表 曲げ強さ (W)

Allowable transfer capability table
 The table below shows the Bending strength applicable for parallel axis only.

商品記号 Catalogue Numbers	回転速度 (min ⁻¹) revolution/min						
	10	100	200	400	800	1,200	1,500
H1D 13R	2.98	29.75	59.46	118.79	237.06	354.80	442.76
H1D 26R	5.95	59.46	118.79	237.06	472.02	704.88	875.19
H1.5D 13R	4.71	47.10	94.12	187.93	374.61	560.04	698.30
H1.5D 26R	9.43	94.12	187.93	374.61	744.23	1,099.52	1,356.90

The above numerical values are equivalent to JGMA formulas as reference only.

動力の換算式は P26 をご参照ください。

Please refer to the conversion formulas of power on page P26.

はすば歯車 / ねじ歯車 HELICAL GEARS

モジュール **1/1.5** 圧力角 20° (並歯) ねじれ角 45°
MODULE 20° PRESSURE ANGLE FULL DEPTH TOOTH 45° Helix Angle

JIS B 1702-1 (ISO) 9 級
System of accuracy : JIS B 1702-1(ISO) class 9



御注文には必ず“フルネームで商品記号”を明記してください。
Please refer to the catalogue reference while ordering.

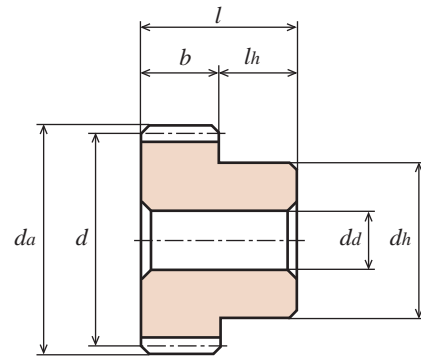

B1形
TYPE B1

SUS304 ステンレス鋼棒 (JIS G 4303) Material : Stainless SUS304 (JIS G 4303)

単位 : mm
Dimensions : mm

商品記号 Catalogue Number	ねじれ方向 Direction of Helix	モジュール Module <i>m</i>	歯数 Number of Teeth <i>z</i>	基準円直径 Reference Diameter <i>d</i>	歯先円直径 Tip Diameter <i>da</i>	歯幅 Face Width <i>b</i>	穴径 Bore Diameter <i>da(H8)</i>	ハブ外径 Hub Diameter <i>dh</i>	ハブ長さ Hub Projection <i>lh</i>	全長 Overall Length <i>l</i>	ねじ Set Screw		重量 Weight <i>W(g)</i>
											2-M(120°)	ls	
H1SU 13R - B	R	1	13	φ18.38	φ20.4	12	φ 8	φ15	10	22	-	-	30.5
H1SU 13L - B	L	1	13	φ18.38	φ20.4	12	φ 8	φ15	10	22	-	-	30.5
H1SU 26R - B	R	1	26	φ36.77	φ38.8	12	φ10	φ32	10	22	-	-	151.1
H1SU 26L - B	L	1	26	φ36.77	φ38.8	12	φ10	φ32	10	22	-	-	151.1
H1SU 13R * B	R	1	13	φ18.38	φ20.4	12	φ 8	φ15	10	22	2-M3	5	30.2
H1SU 13L * B	L	1	13	φ18.38	φ20.4	12	φ 8	φ15	10	22	2-M3	5	30.2
H1SU 26R * B	R	1	26	φ36.77	φ38.8	12	φ10	φ32	10	22	2-M4	5	149.3
H1SU 26L * B	L	1	26	φ36.77	φ38.8	12	φ10	φ32	10	22	2-M4	5	149.3
H1.5SU 13R - B	R	1.5	13	φ27.58	φ30.6	15	φ10	φ23	10	25	-	-	88.4
H1.5SU 13L - B	L	1.5	13	φ27.58	φ30.6	15	φ10	φ23	10	25	-	-	88.4
H1.5SU 26R - B	R	1.5	26	φ55.15	φ58.2	15	φ12	φ40	10	25	-	-	361.4
H1.5SU 26L - B	L	1.5	26	φ55.15	φ58.2	15	φ12	φ40	10	25	-	-	361.4
H1.5SU 13R * B	R	1.5	13	φ27.58	φ30.6	15	φ10	φ23	10	25	2-M4	5	87.4
H1.5SU 13L * B	L	1.5	13	φ27.58	φ30.6	15	φ10	φ23	10	25	2-M4	5	87.4
H1.5SU 26R * B	R	1.5	26	φ55.15	φ58.2	15	φ12	φ40	10	25	2-M5	5	357.9
H1.5SU 26L * B	L	1.5	26	φ55.15	φ58.2	15	φ12	φ40	10	25	2-M5	5	357.9

SUS304 の商品にはセットスクリューは付いておりません。

[*] : Gear with two threaded holes / without set screw.

はすば歯車 (軸平行) 許容伝達動力表 曲げ強さ (W)

Allowable transfer capability table
The table below shows the Bending strength applicable for parallel axis only.

商品記号 Catalogue Numbers	回転速度 (min ⁻¹) revolution/min						
	10	100	200	400	800	1,200	1,500
H1SU 13R	4.07	40.68	81.36	162.73	325.46	477.08	572.13
H1SU 26R	9.50	95.02	190.03	380.06	703.15	952.90	1,110.70
H1.5SU 13R	11.44	114.42	228.83	457.67	894.52	1,237.04	1,460.79
H1.5SU 26R	26.72	267.23	534.46	1,044.61	1,786.69	2,423.37	2,933.19

The above numerical values are equivalent to JGMA formulas as reference only.

動力の換算式は P26 をご参照ください。

Please refer to the conversion formulas of power on page P26.

目次
CONTENTS
インフォメーション
INFORMATION
ギヤボックス
GEAR BOXES
ノーバッキングギヤ
ANTI BACKLASH SPUR GEARS
歯研歯車
GROUND SPUR GEARS
平歯車
SPUR GEARS
内歯車
INTERNAL GEARS
歯研ラック
GROUND RACKS
ラック
RACKS
はすば歯車とスクリュー
HELICAL GEARS AND SCREW GEARS
ワームとワームホイール
WORMS AND WORM WHEELS
かさ歯車
BEVEL GEARS
スプロケット
SPROCKETS
技術資料
REFERENCE DATA

はすば歯車 / ねじ歯車

HELICAL GEARS

モジュール **1/1.5**
MODULE

圧力角 20° (並歯) ねじれ角 45°
20° PRESSURE ANGLE FULL DEPTH TOOTH 45° Helix Angle

JIS B 1702-1 (ISO) 9 級
System of accuracy : JIS B 1702-1(ISO) class 9



New **ねじを2箇所 (120°配) にしました。**
New item with two threaded holes (120°)

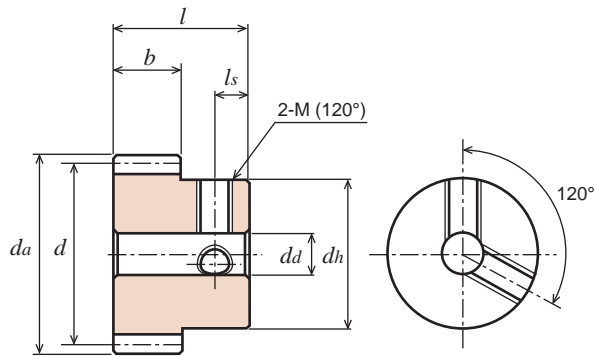

B1形
TYPE B1

S45C 機械構造用炭素鋼 (JIS G 4051)

Material : Carbon Steel (ISO C45)

単位 : mm
Dimensions : mm

商品記号 Catalogue Number	ねじれ方向 Direction of Helix	モジュール Module	歯数 Number of Teeth	基準円直径 Reference Diameter	歯先円直径 Tip Diameter	歯幅 Face Width	穴径 Bore Diameter	ハブ外径 Hub Diameter	ハブ長さ Hub Projection	全長 Overall Length	ねじ Set Screw		重量 Weight
											2-M(120°)	ls	
H1S 13R - B	R	1	13	φ18.38	φ20.4	12	φ 8	φ15	10	22	-	-	0.03
H1S 13L - B	L	1	13	φ18.38	φ20.4	12	φ 8	φ15	10	22	-	-	0.03
H1S 26R - B	R	1	26	φ36.77	φ38.8	12	φ10	φ32	10	22	-	-	0.15
H1S 26L - B	L	1	26	φ36.77	φ38.8	12	φ10	φ32	10	22	-	-	0.15
H1S 13R * B	R	1	13	φ18.38	φ20.4	12	φ 8	φ15	10	22	2-M3	5	0.03
H1S 13L * B	L	1	13	φ18.38	φ20.4	12	φ 8	φ15	10	22	2-M3	5	0.03
H1S 26R * B	R	1	26	φ36.77	φ38.8	12	φ10	φ32	10	22	2-M4	5	0.15
H1S 26L * B	L	1	26	φ36.77	φ38.8	12	φ10	φ32	10	22	2-M4	5	0.15
H1.5S 13R - B	R	1.5	13	φ27.58	φ30.6	15	φ10	φ23	10	25	-	-	0.09
H1.5S 13L - B	L	1.5	13	φ27.58	φ30.6	15	φ10	φ23	10	25	-	-	0.09
H1.5S 26R - B	R	1.5	26	φ55.15	φ58.2	15	φ12	φ40	10	25	-	-	0.36
H1.5S 26L - B	L	1.5	26	φ55.15	φ58.2	15	φ12	φ40	10	25	-	-	0.36
H1.5S 13R * B	R	1.5	13	φ27.58	φ30.6	15	φ10	φ23	10	25	2-M4	5	0.09
H1.5S 13L * B	L	1.5	13	φ27.58	φ30.6	15	φ10	φ23	10	25	2-M4	5	0.09
H1.5S 26R * B	R	1.5	26	φ55.15	φ58.2	15	φ12	φ40	10	25	2-M5	5	0.36
H1.5S 26L * B	L	1.5	26	φ55.15	φ58.2	15	φ12	φ40	10	25	2-M5	5	0.36

歯部高周波焼き入れ HRC 47 ~ 53

Gear tooth surface completed with induction hardening, Hardness HRC 47 to 53.

【*】 (アスタ) にはセットスクリューが2個付いております。 [*] : Gear with two threaded holes / with two set screws.

はすば歯車 (軸平行) 許容伝達動力表 曲げ強さ (kW)

Allowable transfer capability table

The table below shows the Bending strength applicable for parallel axis only.

商品記号 Catalogue Numbers	回転速度 (min ⁻¹) revolution/min						
	10	100	200	400	800	1,200	1,500
H1S 13R	0.009	0.09	0.19	0.38	0.77	1.13	1.36
H1S 26R	0.022	0.22	0.45	0.90	1.67	2.26	2.64
H1.5S 13R	0.027	0.27	0.54	1.08	2.12	2.94	3.47
H1.5S 26R	0.063	0.63	1.27	2.48	4.25	5.76	6.98

歯面強さ (kW)

Allowable transfer capability table (kW) Surface Durability

商品記号 Catalogue Numbers	回転速度 (min ⁻¹) revolution/min						
	10	100	200	400	800	1,200	1,500
H1S 13R	0.003	0.03	0.07	0.14	0.28	0.42	0.51
H1S 26R	0.015	0.15	0.31	0.64	1.20	1.65	1.95
H1.5S 13R	0.010	0.10	0.20	0.41	0.81	1.14	1.36
H1.5S 26R	0.045	0.45	0.91	1.81	3.16	4.37	5.35

The above numerical values are equivalent to JGMA formulas as reference only.

動力の換算式は P26 をご参照ください。 Please refer to the conversion fomulas of power on page P26.



ねじれ角同方向
Same direction of helix

ねじれ角異方向
Different direction of helix

御注文には必ず“フルネームで商品記号”を明記してください。
Please refer to the catalogue reference while ordering.

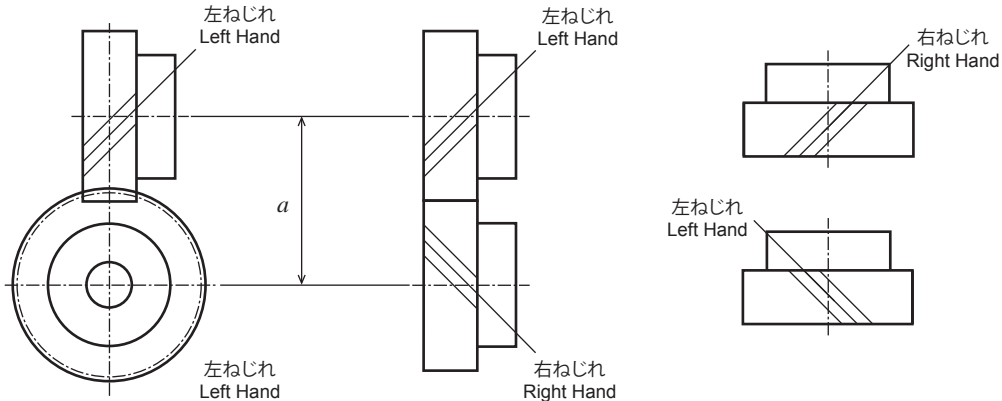

S45C 機械構造用炭素鋼 (JIS G 4051)

Material : Carbon Steel (ISO C45)

単位 : mm
Dimensions : mm

商品記号 Catalogue Number	ねじれ方向 Direction of Helix	モジュール Module <i>m</i>	歯数 Number of Teeth <i>z</i>	基準円直径 Reference Diameter <i>d</i>	歯先円直径 Tip Diameter <i>d_a</i>	歯幅 Face Width <i>b</i>	穴径 Bore Diameter <i>d_a(H8)</i>	ハブ外径 Hub Diameter <i>d_h</i>	ハブ長さ Hub Projection <i>l_h</i>	全長 Overall Length <i>l</i>	重量 Weight <i>W(kg)</i>
H2S 13R - B	R	2	13	φ 36.77	φ 40.8	20	φ12	φ30	13	33	0.21
H2S 13L - B	L	2	13	φ 36.77	φ 40.8	20	φ12	φ30	13	33	0.21
H2S 26R - B	R	2	26	φ 73.54	φ 77.5	20	φ16	φ55	13	33	0.86
H2S 26L - B	L	2	26	φ 73.54	φ 77.5	20	φ16	φ55	13	33	0.86
H2.5S 13R - B	R	2.5	13	φ 45.96	φ 50.9	22	φ14	φ38	14	36	0.37
H2.5S 13L - B	L	2.5	13	φ 45.96	φ 50.9	22	φ14	φ38	14	36	0.37
H2.5S 26R - B	R	2.5	26	φ 91.92	φ 96.9	22	φ18	φ63	14	36	1.41
H2.5S 26L - B	L	2.5	26	φ 91.92	φ 96.9	22	φ18	φ63	14	36	1.41
H3S 13R - B	R	3	13	φ 55.15	φ 61.2	25	φ16	φ44	15	40	0.58
H3S 13L - B	L	3	13	φ 55.15	φ 61.2	25	φ16	φ44	15	40	0.58
H3S 26R - B	R	3	26	φ110.31	φ116.3	25	φ22	φ70	15	40	2.21
H3S 26L - B	L	3	26	φ110.31	φ116.3	25	φ22	φ70	15	40	2.21

歯部高周波焼き入れ HRC 47 ~ 53

Gear tooth surface completed with induction hardening, Hardness HRC 47 to 53.

はすば歯車 (軸平行) 許容伝達動力表 曲げ強さ (kW)

Allowable transfer capability table

The table below shows the Bending strength applicable for parallel axis only.

商品記号 Catalogue Numbers	回転速度 (min ⁻¹) revolution/min						
	10	100	200	400	800	1,200	1,500
H2S 13R - B	0.06	0.64	1.29	2.58	4.77	6.47	7.54
H2S 26R - B	0.15	1.50	2.99	5.53	9.17	12.99	15.73
H2.5S 13R - B	0.11	1.10	2.21	4.41	7.75	10.31	12.43
H2.5S 26R - B	0.26	2.57	5.15	9.04	15.34	21.67	26.20
H3S 13R - B	0.18	1.82	3.63	7.10	12.14	16.47	19.93
H3S 26R - B	0.42	4.22	8.24	14.10	24.43	34.56	42.17
H4S 13R - B	0.38	3.78	7.56	13.99	23.20	32.86	39.78

The above references are JGMA standard.

動力の換算式は P26 をご参照ください。Please refer to the conversion fomulas of power on page P26.

歯面強さ (kW)

Allowable transfer capability table (kW) Surface Durability

商品記号 Catalogue Numbers	回転速度 (min ⁻¹) revolution/min						
	10	100	200	400	800	1,200	1,500
H2S 13R - B	0.02	0.24	0.49	0.99	1.87	2.57	3.03
H2S 26R - B	0.11	1.07	2.16	4.06	6.91	9.98	12.23
H2.5S 13R - B	0.04	0.52	0.85	1.71	3.06	4.14	5.04
H2.5S 26R - B	0.19	1.87	3.79	6.78	11.83	17.08	20.92
H3S 13R - B	0.07	0.71	1.42	2.82	4.92	6.79	8.31
H3S 26R - B	0.31	3.11	6.15	10.75	19.22	27.82	34.40
H4S 13R - B	0.15	1.52	3.06	5.75	9.77	14.12	17.31

Memo

目次
CONTENTS

インフォメーション
INFORMATION

ギヤボックス
GEAR BOXES

ノーバックラッシュギヤ
ANTI BACKLASH SPUR GEARS

歯研平歯車
GROUND SPUR GEARS

平歯車
SPUR GEARS

内歯車
INTERNAL GEARS

歯研ラック
GROUND RACKS

ラック
RACKS

ヘリカル・スクリューギヤ
HELICAL GEARS AND SCREW GEARS

ウォーム・ウォームホイール
WORMS AND WORM WHEELS

かさ歯車
BEVEL GEARS

スプロケット
SPURKETS

技術資料
REFERENCE DATA



ウォーム・ギヤ

Worms and Worm Wheels

商品記号の読み方 Reference of Catalogue Number

ウォーム Worm

W 1 S R 1 = A
W 1 S L 1 - L
W 1 SU R 1 + B

歯車の種類 Kind of Gear	モジュール Module	材質 Material	ねじれ方向 Direction of Thread	条数 Number of Thread	穴仕上 Bores Processed	形状 Type
Worm (ウォーム)	m : 0.5 0.8 1.0 1.25 1.5 2.0 2.5 3.0 4.0 5.0 Expressed the unit of module's size. Module 0.5 and 0.8 as multiple of 100. Example m0.5 → 50 m0.8 → 80	S : S45C Carbon Steel SU : ステンレス (SUS304) Stainless Steel	R : 右ねじれ Right Hand L : 左ねじれ Left Hand	1 : 1条 Single thread 2 : 2条 Double thread	【-】: 旋削加工 Gear without key way / without threaded hole. 【+】: 旋削加工 止めねじ付き Gear with threaded hole / with set screw with out set screw (Please refer the detail) 【=】: 旋削加工 キーみぞ付き Gear with key way / with key.	A : ハブ無し Hubless B : 片ハブ付き with hub on one side. C : 両ハブ付き With hub on both sides. L : 両軸付き With Solid shaft on both sides

ウォーム・ホイール Worm Wheel

G 1 A 20 R 2 + 6
G 1 A 30 R 1 = 10
G 2 A 25 L 1 - 12

歯車の種類 Kind of Gear	モジュール Module	材質 Material	歯数 Number of teeth	ねじれ方向 Direction of Thread	条数 Number of Thread	穴仕上 Bores Processed	穴径 Bore
Worm Wheel (ウォームホイール)	m : 0.5 0.8 1.0 1.25 1.5 2.0 2.5 3.0 4.0 5.0	B : 黄銅 Brass D : ポリアセタール Poly Acetal C : FC200 (鋳物) Cast iron A : CAC702 (アルミニウム青銅) Aluminium Bronze DB : ポリアセタール (黄銅ブッシュ入り) Poly Acetal with brass bush	z : 20 25 30 40 50 60 80 100	R : 右ねじれ Right Hand L : 左ねじれ Left Hand	1 : 1条 Single thread 2 : 2条 Double thread	【-】: 旋削加工 Gear without key way / without threaded hole. 【+】: 旋削加工 止めねじ付き Gear with threaded hole / with set screw with out set screw (Please refer the detail) 【=】: 旋削加工 キーみぞ付き Gear with key way / with key.	単位: ミリメートル Dimension : Millimeter

(材質により若干、記号体系が異なります。)
For CAC702 worm wheel, the material and hub may vary.
Please refer to catalogue information.

KG 転造ウォームについて

Regarding rolling worm of KG

当社のモジュール 0.5 ～ 2.0 のウォームは冷間転造にて造られております。

一般的特徴

Feature of Cold Rolled precision Worm.

- 1) 冷間転造による加工のため、ねじ面の表面は加工硬化によって硬さが向上し、金属の繊維組織が切断されていないので機械切削のウォームに比べ機械的性質も優れております。
- 2) 転造後の表面硬さは母材の硬さの 1.2 倍～ 1.3 倍になり、『ねじ面の硬さは HB240 ～ 260』になります。
- 3) 転造ウォームは、ねじ面の表面粗さが鏡面のため、ウォームホイールと組み合わせるとウォームギヤの寿命が切削をしたウォームとの組み合わせと比較して寿命が長くなります。
- 4) ウォームホイールをポリアセタールなどの軟材質で作った場合、組み合わせるウォームが切削加工品ですと、ねじ山の角でウォームホイールの歯を削りとってしまうことがあります。
転造ウォームは、ねじ面の表面粗さが鏡面になり表面硬さも増し、特にねじ山の角は転造時のもり上がりの為、完全な曲面となり、前述のようなウォームホイールの歯を削りとする現象は無く、その耐久性は極めて優れています。
- 5) 転造ウォームは転造中の素材が均一に塑性変形をしない為、転造特有の酔歩誤差(歩きとも言う)が有ります。転造ウォームが 1 回転 (1 リード中に) する過程において、特定の位置での位相の進み遅れを酔歩誤差といいます。
- 6) 単一ピッチ誤差及び圧力角誤差は転造用ロールダイスの精度によって左右されますが、転造されたウォームの単一ピッチ誤差の最大は 18 μm で圧力角誤差は $\pm 20'$ となっています。

The Module 0.5 to 2.0 of KG-Worms are manufactured by using the cold rolled forming method.

- 1) The hardness of the helicoid surface has been increased by work hardening because cold rolling was performed, and the worms has more excellent mechanical properties than machined worms because the metallic fibrous structure has not been cut.
- 2) The surface hardness after cold rolling process was increased by 1.2 to 1.3 times compare with the hardness of original material, and the hardness of the helicoid surface was increased to HB240 to 260.
- 3) Cold rolling worm is suitable for the miniature module, and can be rotated smoothly without damaging the worm wheel of the Acetal or other soft materials.
- 4) Due to this cold rolling method, the helicoid surface of KG-Worm (M0.5 to 2.0) has a mirror finishing that looks like a mirror. The KG-Precision Cold Rolling Worm is able to provide a smooth engagement and high durability.

転造ウォームの歯部高周波焼入れは、焼き割れをおこす恐れがありますので推奨出来ません。

It is not advisable to apply heat treatments to KG-Cold Rolling Worm that may cause the possibility of 'quenching crack'.

規格品以外に、量産加工の受注を行っております。

If you have any enquiry for Customize make Worm and Worm Wheels, please do not hesitate to contact us.

研削ウォームについても受注致しております。

別途お見積もり致しますので図面をお送り下さい。

We are able to manufacture the Customize make Ground Worm according to your specifications. Please provide your drawings to us and all will be make to order.

相手歯車を弊社以外の商品と組合わせて使用されますと、不具合が発生する恐れがあります。

KG STOCK GEARS 以外の仕様で設計される時は弊社までご相談下さい。

Due to the different manufacturing process of the normal module Worm and Worm Wheels in the industries, it is not advisable to match KG Worm or Worm Wheels with other gear manufacturers.

We are able to fabricate made to order specifications, please do not hesitate to contact us.

ウォームギヤの使用上の注意

Usage precaution

- 理想的な噛み合いを得るためにはウォームとウォームホイールを組み立てるときに、正確に直角度を出して下さい。
- ウォームとウォームホイールのかみ合いにおける歯面の摩擦が大きいので、できるだけ潤滑油の中で運転するような方法でご使用下さい。
- ウォームとウォームホイールは同じねじれ方向、同じ条数の組み合わせでご使用下さい。
- ウォーム軸およびウォームホイール軸はたわまないように軸受はできるだけ歯車に近いところのがんじょうに設計して下さい。
- ウォームに働く軸方向スラストはかなり大きくなりますので注意して下さい。
軸方向スラストについては下図をご参照下さい。

- To obtain ideal engagement of Worm and Worm Wheel's shafts, provide right angle (90°) correctly.
- Lubrication oil is indispensable to Worm and Worm Wheel during operation due to high rate of friction between tooth surface of Worm and Worm Wheel.
- Engagement of the same number of thread (starts) and hand of thread are important to Worm and Worm Wheel.
- The design of the shafts between Worm and Worm Wheel should be in firm condition, and provide bearing which completely support Worm and Worm Wheel as close as possible.
- Provide the bearing that will completely support the Worm gear from the axial thrust when in operation. Refer to Figure below for its axial thrust directions.

ウォームに働く軸方向スラスト

Axial thrust load to Worm gear and location of bearings

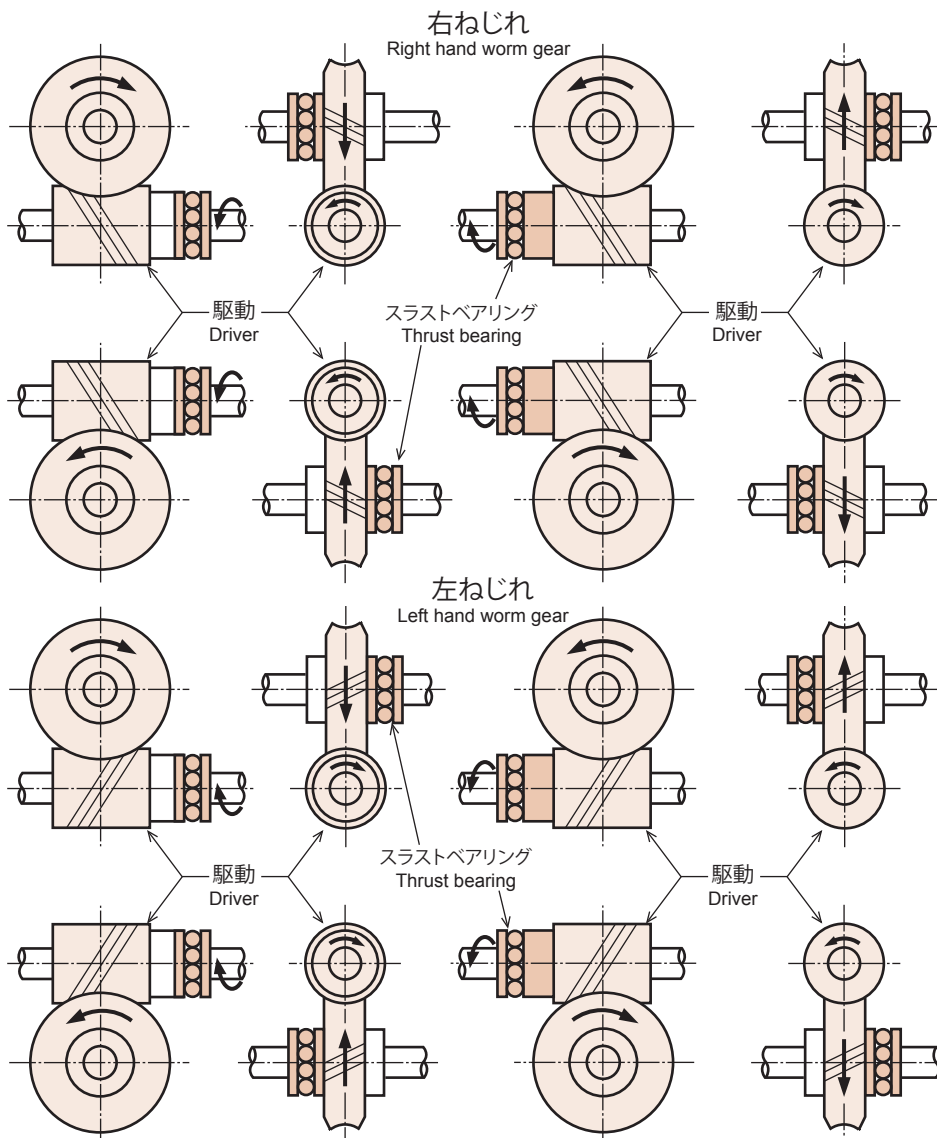

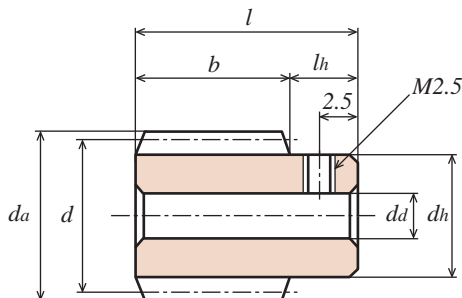

B形
TYPE B

SUS304 ステンレス鋼棒 (JIS G 4303) 精密転造仕上商品です。
 Material : Stainless Steel SUS304 (JIS G 4303) Precision Cold Rolled processed Worm

単位 : mm
 Dimensions : mm

商品記号 Catalogue Number	ねじれ方向 Direction of Thread	条数 Number of Thread z	基準円直径 Reference Diameter d	歯先円直径 Tip Diameter d_a	形 Type	歯幅 Face Width b	穴径 Bore Diameter $d_i(H8)$	ハブ外径 Hub Diameter d_h	ハブ長さ Hub Projection l_h	全長 Overall Length l	進み角 Lead Angle γ	重量 Weight $W(g)$
W50SU R1 + B	R	1	$\phi 9$	$\phi 10$	B	13	$\phi 3$	$\phi 7.6$	5	18	$3^{\circ}11'$	7.3

【+】にはセットスクリーが付いております。(材質はステンレスではありません。)+: Gear with threaded hole / with set screw. (not SUS)



御注文には必ず“フルネームで商品記号”を明記してください。
 Please refer to the catalogue reference while ordering.

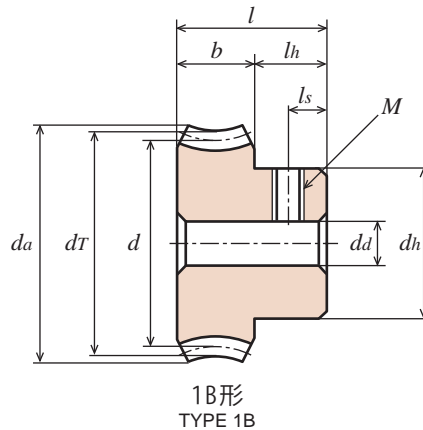

C3604 快削黄銅棒

Material : Brass (ISO CuZn39Pb3) Dimension X: Coefficient of Rack shift.

単位 : mm
 Dimensions : mm

商品記号 Catalogue Number	歯数比 Gear Ratio <i>u</i>	歯数 Number of Teeth <i>z</i>	歯ピッチ 円直径 Pitch Diameter <i>d</i>	転位 係数 <i>x</i>	のどの 直径 Throat Diameter <i>dT</i>	歯先円 直径 Tip Diameter <i>da</i>	形 Type	歯幅 Face Width <i>b</i>	穴径 Bore Diameter <i>da(H8)</i>	ハブ 外径 Hub Diameter <i>dh</i>	ハブ 長さ Hub Projection <i>lh</i>	全長 Overall Length <i>l</i>	ねじ Set Screw		歯合中心 距離 Center Distance <i>A</i>	ウォームのねじれ 方向及び条数 Hand and Thread for Worm	重量 Weight <i>W(g)</i>
													<i>M</i>	<i>ls</i>			
G50B 20 + R1	20	20	φ10	-0.015	φ11	φ11.3	1B	5	φ3	φ9	6	11	M3	3	9.5	R1	5.9
G50B 30 + R1	30	30	φ15	-0.023	φ16	φ16.3	1B	5	φ4	φ12	6	11	M3	3	12.0	R1	11.2
G50B 40 + R1	40	40	φ20	-0.031	φ21	φ21.3	1B	5	φ5	φ15	8	13	M4	4	14.5	R1	22.7
G50B 50 + R1	50	50	φ25	-0.038	φ26	φ26.3	1B	5	φ5	φ16	8	13	M4	4	17.0	R1	29.8

歯先円直径 *da* は理論値ではありません。Dimension *da* does not follow the theory value.

【+】にはセットスクリューが付いております。[-]: Gear with threaded hole / with set screw.

RoHS 対応

2006年11月生産開始分より欧州 RoHS 指令に対応できる商品を提供しています。

We supplied the KG-products with RoHS compliance of EU to all our valued customers since November 2006

ウォームホイールの許容トルク (N・cm) 歯面強さ

Allowable Transfer Capability Torque of Worm Wheel apply to the rotating speed of Worm only (N・cm) as surface durability.

商品記号 Catalogue Numbers	回転速度 (min ⁻¹) revolution/min (Rotating speed of worm)						
	100	250	500	1,000	1,200	1,500	1,800
G50B 20 + R1	21.687	18.482	15.435	12.661	11.975	11.162	10.515
G50B 30 + R1	46.452	40.111	34.015	28.096	26.636	24.892	23.520
G50B 40 + R1	79.380	69.188	59.466	49.343	46.834	43.855	41.493
G50B 50 + R1	120.226	105.546	91.365	76.263	72.451	67.923	64.337

ウォーム回転数に対してのウォームホイール許容トルクです。

The above numerical values are equivalent to JGMA formulas as reference only.

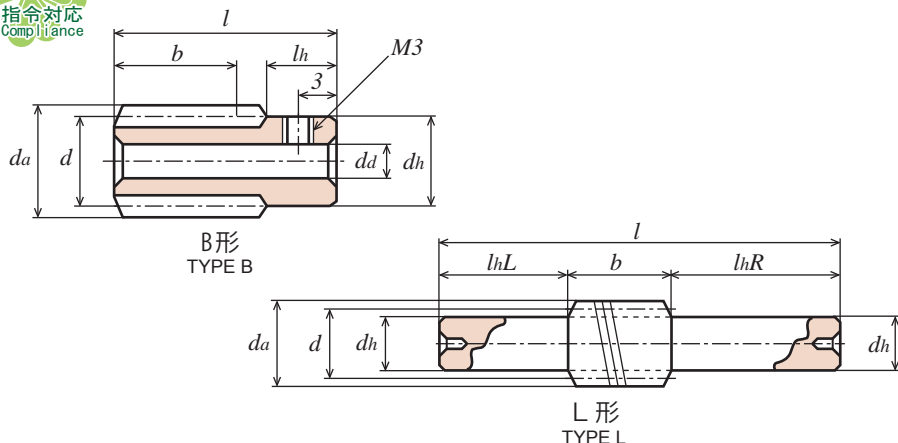

SUS304 ステンレス鋼棒 (JIS G 4303) 精密転造仕上商品です。
Material : Stainless Steel SUS304 (JIS G 4303) Precision Cold Rolled processed Worm

単位 : mm
Dimensions : mm

商品記号 Catalogue Number	ねじれ方向 Direction of Thread	条数 Number of Thread <i>z</i>	基準円直径 Reference Diameter <i>d</i>	歯先円直径 Tip Diameter <i>da</i>	形 Type	歯幅 Face Width <i>b</i>	穴径 Bore Diameter <i>da(H8)</i>	ハブ外径 Hub Diameter <i>dh</i>	ハブ長さ Hub Projection		全長 Overall Length <i>l</i>	進み角 Lead Angle γ	重量 Weight <i>W(g)</i>
									<i>lhL</i>	<i>lhR</i>			
W80SU R1 + B	R	1	$\phi 10.4$	$\phi 12$	B	14	$\phi 5$	$\phi 10.3$	-	6	26	4°24'	18.0
W80SU R1 - L	R	1	$\phi 10.4$	$\phi 12$	L	20	-	$\phi 8 (h9)$	20	40	80	4°24'	40.0

SUS304 の商品にはセットスクリーが付いておりません。Gear with threaded hole / without set screw.

S45C 機械構造用炭素鋼 (JIS G 4051) 精密転造仕上商品です。
Material : Carbon Steel (ISO C45) Precision Cold Rolled processed Worm

単位 : mm
Dimensions : mm

商品記号 Catalogue Number	ねじれ方向 Direction of Thread	条数 Number of Thread <i>z</i>	基準円直径 Reference Diameter <i>d</i>	歯先円直径 Tip Diameter <i>da</i>	形 Type	歯幅 Face Width <i>b</i>	穴径 Bore Diameter <i>da(H8)</i>	ハブ外径 Hub Diameter <i>dh</i>	ハブ長さ Hub Projection		全長 Overall Length <i>l</i>	進み角 Lead Angle γ	重量 Weight <i>W(g)</i>
									<i>lhL</i>	<i>lhR</i>			
W80S R1 + B	R	1	$\phi 10.4$	$\phi 12$	B	14	$\phi 5$	$\phi 10.3$	-	6	26	4°24'	18.0
W80S R1 - L	R	1	$\phi 10.4$	$\phi 12$	L	20	-	$\phi 8 (h9)$	20	40	80	4°24'	40.0

[+]にはセットスクリーが付いております。[+]: Gear with threaded hole / with set screw.



御注文には必ず“フルネームで商品記号”を明記してください。
 Please refer to the catalogue reference while ordering.

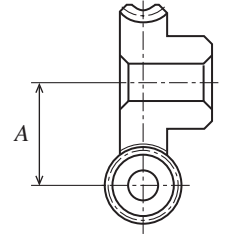
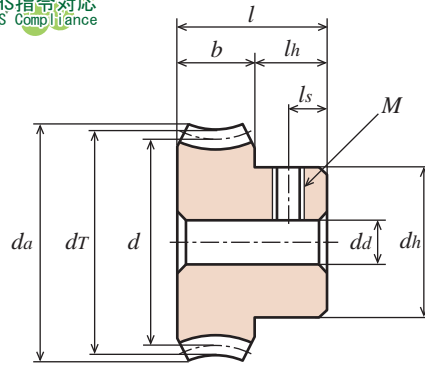

1B形
TYPE 1B

ポリアセタール (白色)

Material : Poly Acetal (White) Dimension X: Coefficient of Rack shift.

単位 : mm
Dimensions : mm

商品記号 Catalogue Number	歯数比 Gear Ratio <i>u</i>	歯数 Number of Teeth <i>z</i>	噛み合ピッチ 円直径 Pitch Diameter <i>d</i>	転位 係数 <i>x</i>	のどの 直径 Throat Diameter <i>dT</i>	歯先円 直径 Tip Diameter <i>da</i>	形 Type	歯幅 Face Width <i>b</i>	穴径 Bore Diameter <i>dd</i>	ハブ 外径 Hub Diameter <i>dh</i>	ハブ 長さ Hub Projection <i>lh</i>	全長 Overall Length <i>l</i>	ねじ Set Screw		噛み合中心 距離 Center Distance <i>A</i>	ウォームのねじれ 方向及び条数 Hand and Thread for Worm	重量 Weight <i>W(g)</i>
													<i>M</i>	<i>ls</i>			
G80D 20 + R1	20	20	φ16	-0.029	φ17.6	φ18.1	1B	6	φ5	φ12	6	12	M3	3	13.2	R1	2.5
G80D 30 + R1	30	30	φ24	-0.044	φ25.6	φ26.1	1B	6	φ5	φ16	6	12	M3	3	17.2	R1	5.2
G80D 40 + R1	40	40	φ32	-0.059	φ33.6	φ34.1	1B	6	φ6	φ18	8	14	M4	4	21.2	R1	10.0
G80D 50 + R1	50	50	φ40	-0.074	φ41.6	φ42.1	1B	6	φ6	φ20	8	14	M4	4	25.2	R1	14.0

歯先円直径 *da* は理論値ではありません。Dimension *da* does not follow the theory value.

【+】にはセットスクリーンが付いております。[-]: Gear with threaded hole / with set screw.

C6191BE アルミニウム青銅、CAC702 アルミニウム青銅鋳物

Material : Aluminum Bronze (JIS C6191BE), Aluminum Bronze casting (JIS CAC702) Dimension X: Coefficient of Rack shift.

単位 : mm
Dimensions : mm

商品記号 Catalogue Number	歯数比 Gear Ratio <i>u</i>	歯数 Number of Teeth <i>z</i>	噛み合ピッチ 円直径 Pitch Diameter <i>d</i>	転位 係数 <i>x</i>	のどの 直径 Throat Diameter <i>dT</i>	歯先円 直径 Tip Diameter <i>da</i>	形 Type	歯幅 Face Width <i>b</i>	穴径 Bore Diameter <i>dd</i> (H8)	ハブ 外径 Hub Diameter <i>dh</i>	ハブ 長さ Hub Projection <i>lh</i>	全長 Overall Length <i>l</i>	ねじ Set Screw		噛み合中心 距離 Center Distance <i>A</i>	ウォームのねじれ 方向及び条数 Hand and Thread for Worm	重量 Weight <i>W(g)</i>
													<i>M</i>	<i>ls</i>			
G80A 20 + R1	20	20	φ16	-0.029	φ17.6	φ18.1	1B	6	φ5	φ12	6	12	M3	3	13.2	R1	12.9
G80A 30 + R1	30	30	φ24	-0.044	φ25.6	φ26.1	1B	6	φ5	φ16	6	12	M3	3	17.2	R1	26.5
G80A 40 + R1	40	40	φ32	-0.059	φ33.6	φ34.1	1B	6	φ6	φ18	8	14	M4	4	21.2	R1	50.7
G80A 50 + R1	50	50	φ40	-0.074	φ41.6	φ42.1	1B	6	φ6	φ20	8	14	M4	4	25.2	R1	75.7

歯先円直径 *da* は理論値ではありません。Dimension *da* does not follow the theory value.

【+】にはセットスクリーンが付いております。[-]: Gear with threaded hole / with set screw.

ウォームホイールの許容トルク (N・m) 歯面強さ

Allowable Transfer Capability Torque of Worm Wheel apply to the rotating speed of Worm only (N・m) as surface durability.

商品記号 Catalogue Numbers	回転速度 (min ⁻¹) revolution/min (Rotating speed of worm)						
	100	250	500	1,000	1,200	1,500	1,800
G80A 20 + R1	0.872	0.735	0.607	0.499	0.470	0.441	0.411
G80A 30 + R1	1.871	1.597	1.352	1.117	1.058	0.989	0.931
G80A 40 + R1	3.194	2.763	2.371	1.960	1.862	1.744	1.646
G80A 50 + R1	4.841	4.223	3.645	3.038	2.891	2.704	2.557

ウォーム回転数に対するウォームホイール許容トルクです。

The above numerical values are equivalent to JGMA formulas as reference only.

- 目次 CONTENTS
- インフォメーション INFORMATION
- ギヤボックス GEAR BOXES
- ノーバッキングバックラッシュギヤ AMT BACKLASH SPUR GEARS
- 歯研平歯車 GROUND SPUR GEARS
- 平歯車 SPUR GEARS
- 内歯車 INTERNAL GEARS
- 歯研ラック GROUND RACKS
- ラック RACKS
- ハブ・スクリューギヤ MECHANICAL GEARS AND SCREW GEARS
- ウォームとウォームホイール WORMS AND WORM WHEELS
- かさ歯車 BEVEL GEARS
- スプロケット SPROCKETS
- 技術資料 REFERENCE DATA

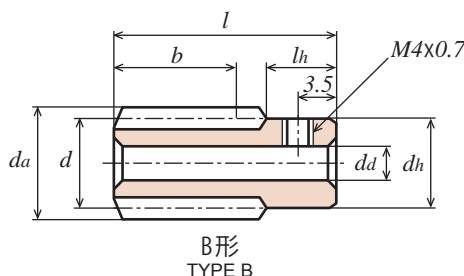

SUS304 ステンレス鋼棒 (JIS G 4303) 精密転造仕上商品です。
Material : Stainless Steel SUS304 (JIS G 4303) Precision Cold Rolled processed Worm

単位 : mm
Dimensions : mm

商品記号 Catalogue Number	ねじれ方向 Direction of Thread	条数 Number of Thread z	基準円直径 Reference Diameter d	歯先円直径 Tip Diameter d_a	形 Type	歯幅 Face Width b	穴径 Bore Diameter $d_a(H8)$	ハブ外径 Hub Diameter d_h	ハブ長さ Hub Projection l_h	全長 Overall Length l	進み角 Lead Angle γ	重量 Weight $W(g)$
W1SU R1 + B	R	1	$\phi 16$	$\phi 18$	B	15.5	$\phi 6$	$\phi 15.85$	7	32	$3^{\circ}35'$	42.0
W1SU R2 + B	R	2	$\phi 16$	$\phi 18$	B	15	$\phi 6$	$\phi 15.85$	7	32	$7^{\circ}11'$	42.0

SUS304 の商品にはセットスクリーが付いておりません。Gear with threaded hole / without set screw.

ウォームとウォームホイールのねじれ方向及び条数は同じ組み合わせでご使用下さい。

(W : R1 → G : R1) (W : R2 → G : R2)

Engagement of the same number of thread (starts) and hand of thread are important to Worm and Worm Wheel.

Worm: Right hand with single thread
 Worm Wheel: Right hand with single thread.

転造加工について

- 素材の塑性変形の原理を利用し、一對の転造ロールの間に材料を置き両側から油圧力により強圧しながら回転させて加工する。
- 材料は、硬度 HB220 以下であれば何でも加工できるが非鉄金属はできない。S45C 以下、S20C 程度が最適。
- ねじピッチ 0.8mm ~ 8mm
- 単体物は外径 $\phi 100$ 、長さ 150 迄。
- ねじの山の型は、自由に設定できる。ねじ、ウォーム、セレーション等。

Regarding the Precision Cold Rolling processed.

With regard to the precision Cold Rolling process of the worm, in respect of theory of plasticity material, the fabrication of the material of Cold Rolled-worm is produced by rotating with hydraulic pressing between both sides of the rolling tooth machine.

For the material of worm without nonferrous metal that can use HB220 or below, S20C to S45C are the most suitable process of the Cold Rolling.

Thread pitch 0.8 to 8.0mm

Our capacity of maximum dimension and length: $\phi 100 \times 150$ mm

It may be possible that this process can make to design of the screw, worm and serration to the free type of thread

御注文には必ず“フルネームで商品記号”を明記してください。
Please refer to the catalogue reference while ordering.

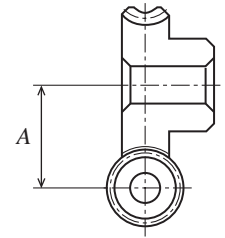
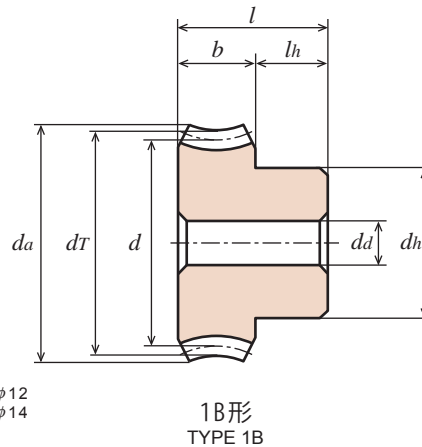
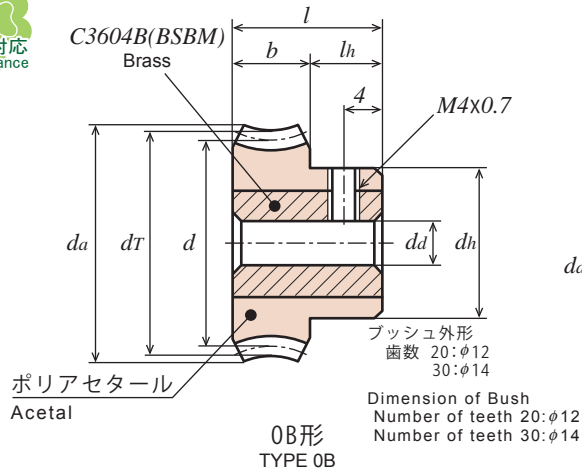

ポリアセタール (白色) 黄銅ブッシュ入り (C3604B)

Material : Poly Acetal (with Brass Bushing) Dimension X: Coefficient of Rack shift.

単位 : mm
Dimensions : mm

商品記号 Catalogue Number	歯数比 Gear Ratio <i>u</i>	歯数 Number of Teeth <i>z</i>	噛合ピッチ 円直径 Pitch Diameter <i>d</i>	転位係数 <i>x</i>	のどの 直径 Throat Diameter <i>dT</i>	歯先円 直径 Tip Diameter <i>da</i>	形 Type	歯幅 Face Width <i>b</i>	穴径 Bore Diameter <i>da(HS)</i>	ハブ 外径 Hub Diameter <i>dh</i>	ハブ 長さ Hub Projection <i>lh</i>	全長 Overall Length <i>l</i>	噛合中心 距離 Center Distance <i>A</i>	ウォームのねじれ 方向及び条数 Hand and Thread for Worm	重量 Weight <i>W(g)</i>
G1DB 20 + R2	10	20	φ20	-0.079	φ22	φ23	0B	8	φ6	φ16	9	17	18	R2	15.0
G1DB 20 + R1	20	20	φ20	-0.019	φ22	φ23	0B	8	φ6	φ16	9	17	18	R1	15.0
G1DB 30 + R1	30	30	φ30	-0.029	φ32	φ33	0B	8	φ6	φ20	9	17	23	R1	25.7

[+]にはセットスクリーが付いております。[+]: Gear with threaded hole / with set screw.

RoHS 対応

2006年11月生産開始分より欧州 RoHS 指令に対応できる商品を提供しています。
We supplied the KG-products with RoHS compliance of EU to all our valued customers since November 2006

ポリアセタール (白色) ブッシュなし

Material : Poly Acetal (White) Dimension X: Coefficient of Rack shift.

単位 : mm
Dimensions : mm

商品記号 Catalogue Number	歯数比 Gear Ratio <i>u</i>	歯数 Number of Teeth <i>z</i>	噛合ピッチ 円直径 Pitch Diameter <i>d</i>	転位係数 <i>x</i>	のどの 直径 Throat Diameter <i>dT</i>	歯先円 直径 Tip Diameter <i>da</i>	形 Type	歯幅 Face Width <i>b</i>	穴径 Bore Diameter <i>da</i>	ハブ 外径 Hub Diameter <i>dh</i>	ハブ 長さ Hub Projection <i>lh</i>	全長 Overall Length <i>l</i>	噛合中心 距離 Center Distance <i>A</i>	ウォームのねじれ 方向及び条数 Hand and Thread for Worm	重量 Weight <i>W(g)</i>
G1D 20 - R2	10	20	φ 20	-0.079	φ 22	φ 23.5	1B	10	φ 6	φ17	8	18	18	R2	6.0
G1D 20 - R1	20	20	φ 20	-0.019	φ 22	φ 23.5	1B	10	φ 6	φ17	8	18	18	R1	6.0
G1D 30 - R2	15	30	φ 30	-0.118	φ 32	φ 33.5	1B	10	φ 6	φ22	8	18	23	R2	14.0
G1D 30 - R1	30	30	φ 30	-0.029	φ 32	φ 33.5	1B	10	φ 6	φ22	8	18	23	R1	14.0
G1D 40 - R1	40	40	φ 40	-0.039	φ 42	φ 43.5	1B	10	φ 8	φ25	8	18	28	R1	22.2
G1D 50 - R1	50	50	φ 50	-0.048	φ 52	φ 53.5	1B	10	φ 8	φ30	8	18	33	R1	34.7
G1D 60 - R1	60	60	φ 60	-0.058	φ 62	φ 63.5	1B	10	φ10	φ30	8	18	38	R1	46.0
G1D 80 - R1	80	80	φ 80	-0.078	φ 82	φ 83.5	1B	10	φ10	φ40	8	18	48	R1	84.0
G1D 100 - R1	100	100	φ100	-0.098	φ102	φ103.5	1B	10	φ10	φ40	8	18	58	R1	125.0

ウォームギヤ

WORMS AND WORM WHEELS

モジュール
MODULE

1

圧力角 20° (並歯)
20° PRESSURE ANGLE FULL DEPTH TOOTH

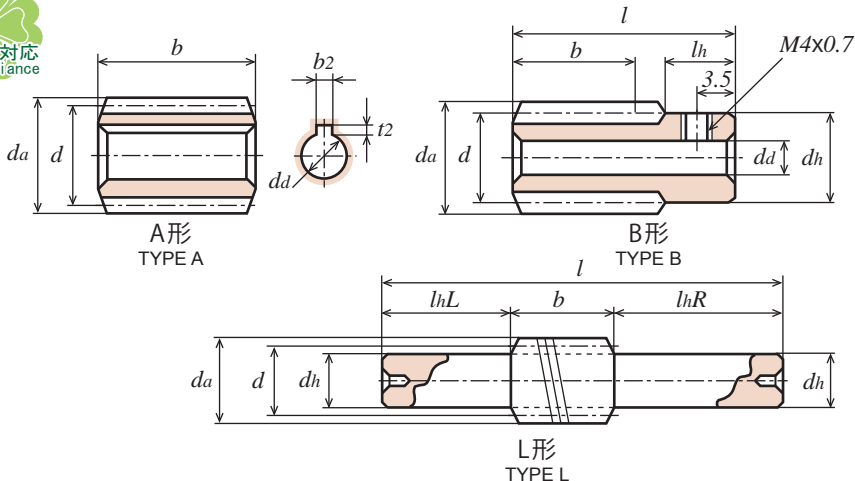

S45C 機械構造用炭素鋼 (JIS G 4051) 精密転造仕上商品です。
Material : Carbon Steel (ISO C45) Precision Cold Rolled processed Worm

単位 : mm
Dimensions : mm

商品記号 Catalogue Number	ねじれ方向 Direction of Thread	条数 Number of Thread z	基準円直径 Reference Diameter d	歯先円直径 Tip Diameter d_a	形 Type	歯幅 Face Width b	穴径 Bore Diameter $d_a(H8)$	ハブ外径 Hub Diameter d_h	ハブ長さ Hub Projection		全長 Overall Length l	キーみぞ Key Way $b_2 \times t_2$	進み角 Lead Angle γ	重量 Weight $W(g)$
									l_{hL}	l_{hR}				
W1S R1 = A	R	1	$\phi 16$	$\phi 18$	A	25	$\phi 8$	-	-	-	25	3×1.4	$3^\circ 35'$	28.0
W1S R1 + B	R	1	$\phi 16$	$\phi 18$	B	17	$\phi 6$	$\phi 15.85$	-	7	32	-	$3^\circ 35'$	42.0
W1S R1 + B - 8	R	1	$\phi 16$	$\phi 18$	B	17	$\phi 8$	$\phi 15.85$	-	7	32	-	$3^\circ 35'$	42.0
W1S R1 - L	R	1	$\phi 16$	$\phi 18$	L	25	-	$\phi 13(h8)$	25	50	100	-	$3^\circ 35'$	120.0
W1S R2 = A	R	2	$\phi 16$	$\phi 18$	A	25	$\phi 8$	-	-	-	25	3×1.4	$7^\circ 11'$	28.0
W1S R2 + B	R	2	$\phi 16$	$\phi 18$	B	16.5	$\phi 6$	$\phi 15.85$	-	7	32	-	$7^\circ 11'$	42.0
W1S R2 + B - 8	R	2	$\phi 16$	$\phi 18$	B	16.5	$\phi 8$	$\phi 15.85$	-	7	32	-	$7^\circ 11'$	42.0
W1S R2 - L	R	2	$\phi 16$	$\phi 18$	L	25	-	$\phi 13(h8)$	25	50	100	-	$7^\circ 11'$	120.0
W1S L1 = A	L	1	$\phi 16$	$\phi 18$	A	25	$\phi 8$	-	-	-	25	3×1.4	$3^\circ 35'$	28.0
W1S L1 + B	L	1	$\phi 16$	$\phi 18$	B	17	$\phi 6$	$\phi 15.85$	-	7	32	-	$3^\circ 35'$	42.0
W1S L1 - L	L	1	$\phi 16$	$\phi 18$	L	25	-	$\phi 13(h8)$	25	50	100	-	$3^\circ 35'$	120.0
W1S L2 = A	L	2	$\phi 16$	$\phi 18$	A	25	$\phi 8$	-	-	-	25	3×1.4	$7^\circ 11'$	28.0
W1S L2 + B	L	2	$\phi 16$	$\phi 18$	B	16.5	$\phi 6$	$\phi 15.85$	-	7	32	-	$7^\circ 11'$	42.0
W1S L2 - L	L	2	$\phi 16$	$\phi 18$	L	25	-	$\phi 13(h8)$	25	50	100	-	$7^\circ 11'$	120.0

【=】にはキー材が付いております。【=】: Gear with key way / with key.

【+】にはセットスクリューが付いております。

【+】: Gear with threaded hole / with set screw.

How to identify the left and right hand threads for worm and worm wheel.

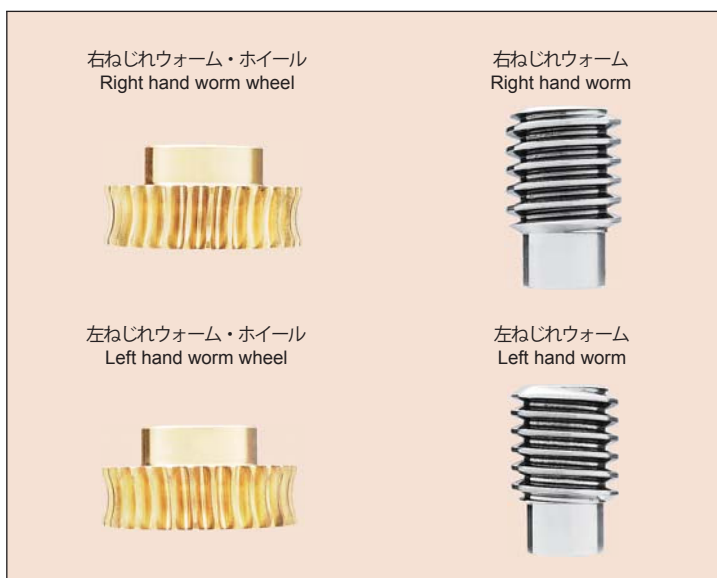



御注文には必ず“フルネームで商品記号”を明記してください。
Please refer to the catalogue reference while ordering.

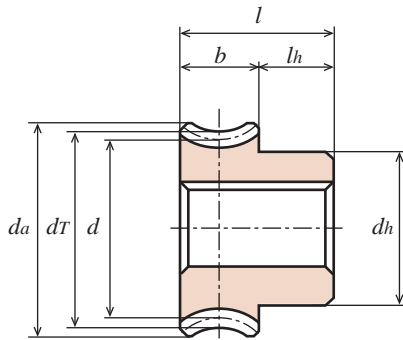

1B形
TYPE 1B

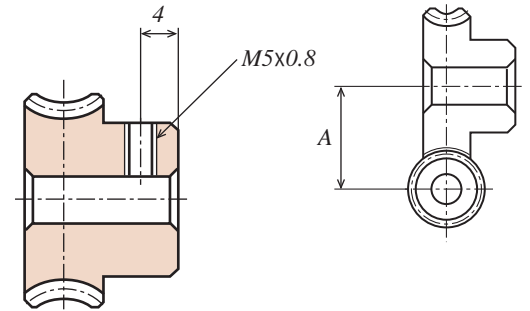
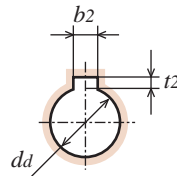

1B形
TYPE 1B

C6191BE アルミニウム青銅

Material : Aluminum Bronze(JIS C6191BE) Dimension X: Coefficient of Rack shift.

単位 : mm
Dimensions : mm

商品記号 Catalogue Number	歯数比 Gear Ratio u	歯数 Number of Teeth z	噛み合ピッチ 円直径 Pitch Diameter d	転位係数 係数 x	のどの直径 Throat Diameter d _T	歯先円直径 Tip Diameter d _a	形 Type	歯幅 Face Width b	穴径 Bore Diameter d _a (H8)	ハブ 外径 Hub Diameter d _h	ハブ 長さ Hub Projection l _h	全長 Overall Length l	キー みぞ Key Way b ₂ × t ₂	噛み合中心 距離 Center Distance A	ウォームのねじれ 方向及び条数 Hand and Thread for Worm	重量 Weight W(g)
G1A 20R2 + 6	10	20	φ20	-0.079	φ22	φ23.5	1B	10	φ 6	φ17	8	18	-	18	R2	35.0
G1A 20R2 + 8	10	20	φ20	-0.079	φ22	φ23.5	1B	10	φ 8	φ17	8	18	-	18	R2	32.0
G1A 20R2 = 8	10	20	φ20	-0.079	φ22	φ23.5	1B	10	φ 8	φ17	8	18	3 × 1.4	18	R2	31.7
G1A 20R1 + 6	20	20	φ20	-0.019	φ22	φ23.5	1B	10	φ 6	φ17	8	18	-	18	R1	35.0
G1A 20R1 + 8	20	20	φ20	-0.019	φ22	φ23.5	1B	10	φ 8	φ17	8	18	-	18	R1	32.0
G1A 20R1 = 8	20	20	φ20	-0.019	φ22	φ23.5	1B	10	φ 8	φ17	8	18	3 × 1.4	18	R1	31.7
G1A 20L2 + 6	10	20	φ20	-0.079	φ22	φ23.5	1B	10	φ 6	φ17	8	18	-	18	L2	35.0
G1A 20L1 + 6	20	20	φ20	-0.019	φ22	φ23.5	1B	10	φ 6	φ17	8	18	-	18	L1	35.0
G1A 30R2 + 6	15	30	φ30	-0.118	φ32	φ33.5	1B	10	φ 6	φ22	8	18	-	23	R2	73.0
G1A 30R2 + 8	15	30	φ30	-0.118	φ32	φ33.5	1B	10	φ 8	φ22	8	18	-	23	R2	69.5
G1A 30R2 = 10	15	30	φ30	-0.118	φ32	φ33.5	1B	10	φ10	φ22	8	18	3 × 1.4	23	R2	66.0
G1A 30R1 + 6	30	30	φ30	-0.029	φ32	φ33.5	1B	10	φ 6	φ22	8	18	-	23	R1	73.0
G1A 30R1 + 8	30	30	φ30	-0.029	φ32	φ33.5	1B	10	φ 8	φ22	8	18	-	23	R1	69.5
G1A 30R1 = 10	30	30	φ30	-0.029	φ32	φ33.5	1B	10	φ10	φ22	8	18	3 × 1.4	23	R1	66.0
G1A 30L2 + 6	15	30	φ30	-0.118	φ32	φ33.5	1B	10	φ 6	φ22	8	18	-	23	L2	73.0
G1A 30L1 + 6	30	30	φ30	-0.029	φ32	φ33.5	1B	10	φ 6	φ22	8	18	-	23	L1	73.0

【=】にはキー材が付いております。【=】: Gear with key way / with key.

【+】にはセットスクリーンが付いております。【+】: Gear with threaded hole / with set screw.

ウォームとウォームホイールのねじれ方向及び条数は同じ組み合わせでご使用下さい。

(W : R1 → G : R1) (W : L2 → G : L2)

Engagement of the same number of thread (starts) and hand of thread are important to Worm and Worm Wheel.

Worm: Right hand with single thread
Worm Wheel: Right hand with single thread.

ウォームホイールの許容トルク (N・m) 歯面強さ

Allowable Transfer Capability Torque of Worm Wheel apply to the rotating speed of Worm only (N・m) as surface durability.

商品記号 Catalogue Numbers	回転速度 (min ⁻¹) revolution/min (Rotating speed of worm)						
	100	250	500	1,000	1,200	1,500	1,800
G1A 20R2 + 6	2.185	1.793	1.479	1.185	1.107	1.009	0.980
G1A 20R1 + 6	2.322	1.930	1.597	1.303	1.225	1.146	1.078
G1A 20L2 + 6	2.185	1.793	1.479	1.185	1.107	1.009	0.980
G1A 20L1 + 6	2.322	1.930	1.597	1.303	1.225	1.146	1.078
G1A 30R2 + 6	4.488	3.547	2.900	2.312	2.175	1.989	1.852
G1A 30R1 + 6	4.978	4.184	3.528	2.891	2.724	2.548	2.401
G1A 30L2 + 6	4.488	3.547	2.900	2.312	2.175	1.989	1.852
G1A 30L1 + 6	4.978	4.184	3.528	2.891	2.724	2.548	2.401

ウォーム回転数に対するウォームホイール許容トルクです。

The above references are JGMA standard.

目次 CONTENTS

インフォメーション INFORMATION

ギヤボックス GEAR BOXES

ノーバッキングギヤ ANTI BACKLASH SPUR GEARS

歯研研歯歯車 GROUND SPUR GEARS

平歯車 SPUR GEARS

内歯車 INTERNAL GEARS

歯研ラック GROUND RACKS

ラック RACKS

らせん歯車とスクリーン HEILICAL GEARS AND SCREW GEARS

ウォームとウォームホイール WORMS AND WORM WHEELS

かさ歯車 BEVEL GEARS

スプロケット SPROCKETS

技術資料 REFERENCE DATA

ウォームギヤ

WORMS AND WORM WHEELS

モジュール
MODULE

1

圧力角 20° (並歯)
20° PRESSURE ANGLE FULL DEPTH TOOTH

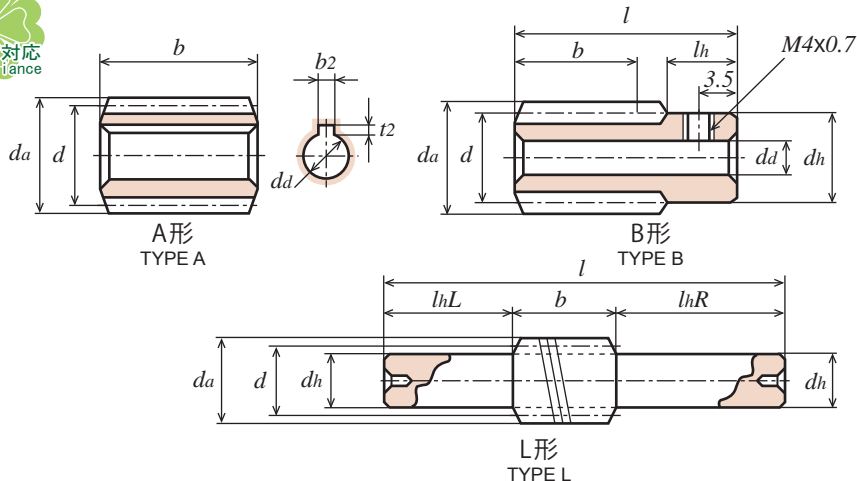

S45C 機械構造用炭素鋼 (JIS G 4051) 精密転造仕上商品です。
Material : Carbon Steel (ISO C45) Precision Cold Rolled processed Worm

単位 : mm
Dimensions : mm

商品記号 Catalogue Number	ねじれ方向 Direction of Thread	条数 Number of Thread <i>z</i>	基準円直径 Reference Diameter <i>d</i>	歯先円直径 Tip Diameter <i>da</i>	形 Type	歯幅 Face Width <i>b</i>	穴径 Bore Diameter <i>da</i> (H8)	ハブ外径 Hub Diameter <i>dh</i>	ハブ長さ Hub Projection		全長 Overall Length <i>l</i>	キーみぞ Key Way <i>b2 × t2</i>	進み角 Lead Angle <i>γ</i>	重量 Weight <i>W</i> (g)
									<i>lhL</i>	<i>lhR</i>				
W1S R1 = A	R	1	φ16	φ18	A	25	φ8	-	-	-	25	3 × 1.4	3°35'	28.0
W1S R1 + B	R	1	φ16	φ18	B	17	φ6	φ15.85	-	7	32	-	3°35'	42.0
W1S R1 + B - 8	R	1	φ16	φ18	B	17	φ8	φ15.85	-	7	32	-	3°35'	42.0
W1S R1 - L	R	1	φ16	φ18	L	25	-	φ13(h8)	25	50	100	-	3°35'	120.0
W1S R2 = A	R	2	φ16	φ18	A	25	φ8	-	-	-	25	3 × 1.4	7°11'	28.0
W1S R2 + B	R	2	φ16	φ18	B	16.5	φ6	φ15.85	-	7	32	-	7°11'	42.0
W1S R2 + B - 8	R	2	φ16	φ18	B	16.5	φ8	φ15.85	-	7	32	-	7°11'	42.0
W1S R2 - L	R	2	φ16	φ18	L	25	-	φ13(h8)	25	50	100	-	7°11'	120.0
W1S L1 = A	L	1	φ16	φ18	A	25	φ8	-	-	-	25	3 × 1.4	3°35'	28.0
W1S L1 + B	L	1	φ16	φ18	B	17	φ6	φ15.85	-	7	32	-	3°35'	42.0
W1S L1 - L	L	1	φ16	φ18	L	25	-	φ13(h8)	25	50	100	-	3°35'	120.0
W1S L2 = A	L	2	φ16	φ18	A	25	φ8	-	-	-	25	3 × 1.4	7°11'	28.0
W1S L2 + B	L	2	φ16	φ18	B	16.5	φ6	φ15.85	-	7	32	-	7°11'	42.0
W1S L2 - L	L	2	φ16	φ18	L	25	-	φ13(h8)	25	50	100	-	7°11'	120.0

【=】にはキー材が付いております。【=】: Gear with key way / with key.

【+】にはセットスクリューが付いております。

【+】: Gear with threaded hole / with set screw.

How to identify the left and right hand threads for worm and worm wheel.

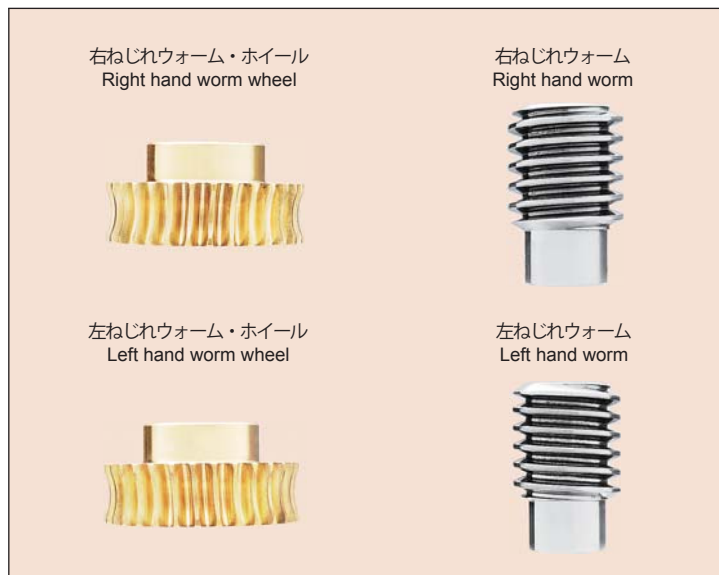

御注文には必ず“フルネームで商品記号”を明記してください。
Please refer to the catalogue reference while ordering.

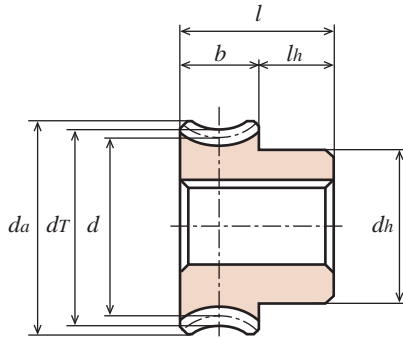

1B形
TYPE 1B

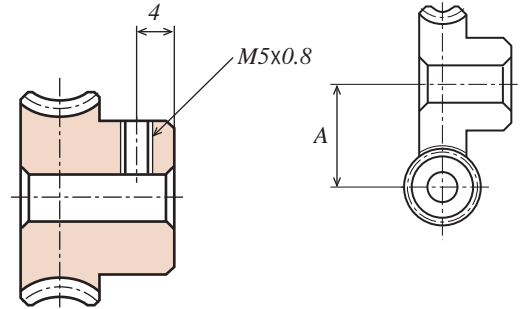
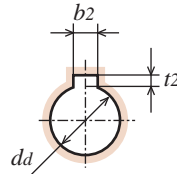

1B形
TYPE 1B

CAC702 アルミニウム青銅鋳物

Material : Aluminum Bronze Casting (JIS CAC702) Dimension X: Coefficient of Rack shift.

単位 : mm
Dimensions : mm

商品記号 Catalogue Number	歯数比 Gear Ratio u	歯数 Number of Teeth z	噛み合ピッチ円直径 Pitch Diameter d	転位係数 x	のどの直径 Throat Diameter d _T	歯先円直径 Tip Diameter d _a	形 Type	歯幅 Face Width b	穴径 Bore Diameter d _a (H8)	ハブ外径 Hub Diameter d _h	ハブ長さ Hub Projection l _h	全長 Overall Length l	キミぞ Key Way b ₂ × t ₂	噛み合中心距離 Center Distance A	ウォームのねじれ方向及び条数 Hand and Thread for Worm	重量 Weight W(g)
G1A 40R2 + 8	20	40	φ40	-0.158	φ42	φ43.5	1B	10	φ 8	φ25	8	18	-	28	R2	121.0
G1A 40R1 + 8	40	40	φ40	-0.039	φ42	φ43.5	1B	10	φ 8	φ25	8	18	-	28	R1	121.0
G1A 40R1 + 10	40	40	φ40	-0.039	φ42	φ43.5	1B	10	φ10	φ25	8	18	-	28	R1	119.5
G1A 40R1 = 10	40	40	φ40	-0.039	φ42	φ43.5	1B	10	φ10	φ25	8	18	3 × 1.4	28	R1	118.0
G1A 40L2 + 8	20	40	φ40	-0.158	φ42	φ43.5	1B	10	φ 8	φ25	8	18	-	28	L2	121.0
G1A 40L1 + 8	40	40	φ40	-0.039	φ42	φ43.5	1B	10	φ 8	φ25	8	18	-	28	L1	120.0
G1A 50R2 + 8	25	50	φ50	-0.197	φ52	φ53.5	1B	10	φ 8	φ30	8	18	-	33	R2	190.0
G1A 50R1 + 8	50	50	φ50	-0.048	φ52	φ53.5	1B	10	φ 8	φ30	8	18	-	33	R1	190.0
G1A 50R1 + 10	50	50	φ50	-0.048	φ52	φ53.5	1B	10	φ10	φ30	8	18	-	33	R1	187.5
G1A 50R1 = 12	50	50	φ50	-0.048	φ52	φ53.5	1B	10	φ12	φ30	8	18	4 × 1.8	33	R1	185.0
G1A 50L2 + 8	25	50	φ50	-0.197	φ52	φ53.5	1B	10	φ 8	φ30	8	18	-	33	L2	190.0
G1A 50L1 + 8	50	50	φ50	-0.048	φ52	φ53.5	1B	10	φ 8	φ30	8	18	-	33	L1	190.0

[=] にはキー材が付いております。 [=] : Gear with key way / with key.
[+] にはセットスクリューが付いております。 [+] : Gear with threaded hole / with set screw.

ウォームとウォームホイールのねじれ方向及び条数は同じ組み合わせでご利用下さい。

(W : R1 → G : R1) (W : L2 → G : L2)

Engagement of the same number of thread (starts) and hand of thread are important to Worm and Worm Wheel.

Worm: Right hand with single thread
Worm Wheel: Right hand with single thread.

ウォームホイールの許容トルク (N・m) 歯面強さ

Allowable Transfer Capability Torque of Worm Wheel apply to the rotating speed of Worm only (N・m) as surface durability.

商品記号 Catalogue Numbers	回転速度 (min ⁻¹) revolution/min (Rotating speed of worm)						
	100	250	500	1,000	1,200	1,500	1,800
G1A 40R2 + 8	8.339	6.918	5.742	4.684	4.390	4.096	3.861
G1A 40R1 + 8	8.496	7.212	6.164	5.086	4.792	4.488	4.243
G1A 40L2 + 8	8.339	6.918	5.742	4.684	4.390	4.096	3.861
G1A 40L1 + 8	8.496	7.212	6.164	5.086	4.792	4.488	4.243
G1A 50R2 + 8	12.965	10.838	8.878	7.271	6.830	6.379	6.017
G1A 50R1 + 8	12.926	11.054	9.476	7.859	7.408	6.948	6.585
G1A 50L2 + 8	12.965	10.838	8.878	7.271	6.830	6.379	6.017
G1A 50L1 + 8	12.926	11.054	9.476	7.859	7.408	6.948	6.585

ウォーム回転数に対するウォームホイール許容トルクです。

The above references are JGMA standard.

目次 CONTENTS

インフォメーション INFORMATION

ギヤボックス GEAR BOXES

ノーバッキングギヤ ANTI BACKLASH SPUR GEARS

歯研研歯歯車 GROUND SPUR GEARS

平歯車 SPUR GEARS

内歯車 INTERNAL GEARS

歯研ラック GROUND RACKS

ラック RACKS

ハニカム・スチールギヤ HONEYCOMB AND STEEL GEARS

ウォームとウォームホイール WORMS AND WORM WHEELS

かさ歯車 BEVEL GEARS

スプロケット SPROCKETS

技術資料 REFERENCE DATA

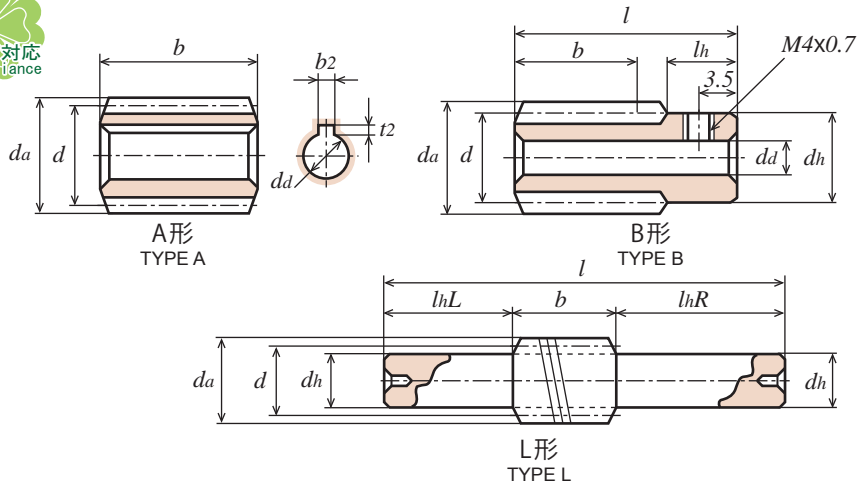

S45C 機械構造用炭素鋼 (JIS G 4051) 精密転造仕上商品です。
Material : Carbon Steel (ISO C45) Precision Cold Rolled processed Worm

単位 : mm
 Dimensions : mm

商品記号 Catalogue Number	ねじれ方向 Direction of Thread	条数 Number of Thread z	基準円直径 Reference Diameter d	歯先円直径 Tip Diameter da	形 Type	歯幅 Face Width b	穴径 Bore Diameter $da(H8)$	ハブ外径 Hub Diameter dh	ハブ長さ Hub Projection		全長 Overall Length l	キーみぞ Key Way $b_2 \times t_2$	進み角 Lead Angle γ	重量 Weight $W(g)$
									lhL	lhR				
W1S R1 = A	R	1	$\phi 16$	$\phi 18$	A	25	$\phi 8$	-	-	25	3×1.4	$3^\circ 35'$	28.0	
W1S R1 + B	R	1	$\phi 16$	$\phi 18$	B	17	$\phi 6$	$\phi 15.85$	-	7	32	-	$3^\circ 35'$	42.0
W1S R1 + B - 8	R	1	$\phi 16$	$\phi 18$	B	17	$\phi 8$	$\phi 15.85$	-	7	32	-	$3^\circ 35'$	42.0
W1S R1 - L	R	1	$\phi 16$	$\phi 18$	L	25	-	$\phi 13(h8)$	25	50	100	-	$3^\circ 35'$	120.0

【=】にはキー材が付いております。【=】: Gear with key way / with key.

【+】にはセットスクリーが付いております。【+】: Gear with threaded hole / with set screw.

転造加工について

- 素材の塑性変形の原理を利用し、一對の転造ロールの間に材料を置き両側から油圧力により強圧しながら回転させて加工する。
- 材料は、硬度 HB220 以下であれば何でも加工できるが非鉄金属はできない。S45C 以下、S20C 程度が最適。
- ねじピッチ 0.8mm ~ 8mm
- 単体物は外径 $\phi 100$ 、長さ 150 迄。
- ねじの山の型は、自由に設定できる。ねじ、ウォーム、セレーション等。

Regarding the Precision Cold Rolling processed.

With regard to the precision Cold Rolling process of the worm, in respect of theory of plasticity material, the fabrication of the material of Cold Rolled-worm is produced by rotating with hydraulic pressing between both sides of the rolling tooth machine.

For the material of worm without nonferrous metal that can use HB220 or below, S20C to S45C are the most suitable process of the Cold Rolling.

Thread pitch 0.8 to 8.0mm

Our capacity of maximum dimension and length: $\phi 100 \times 150$ mm

It may be possible that this process can make to design of the screw, worm and serration to the free type of thread

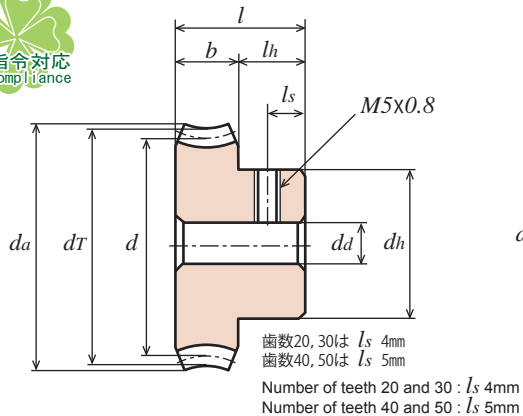

1B形
TYPE 1B

御注文には必ず“フルネームで商品記号”を明記してください。
Please refer to the catalogue reference while ordering.

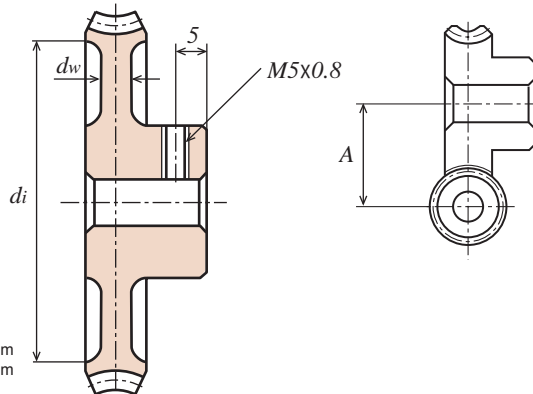

2B形
TYPE 2B

FC200 ねずみ鋳鉄 (JIS G 5501)

Material : Grey Iron casting (JIS FC200) Dimension X: Coefficient of Rack shift.

単位 : mm
Dimensions : mm

商品記号 Catalogue Number	歯数比 Gear Ratio u	歯数 Number of Teeth z	噛合ピッチ 円直径 Pitch Diameter d	転位係数 x	のどの 直径 Throat Diameter dT	歯先円 直径 Tip Diameter da	形 Type	歯幅 Face Width b	穴径 Bore Diameter da(H8)	ハブ 外径 Hub Diameter dh	ハブ 長さ Hub Projection lh	全長 Overall Length l	リム 内径 Dimension of Rim di	ウェブ 厚さ Thickness of Web dw	噛合中心 距離 Center Distance A	ウォームのねじれ 方向及び条数 Hand and Thread for Worm	重量 Weight W(g)
G1C 30 + R1	30	30	φ 30	-0.029	φ 32	φ 33	1B	8	φ 6	φ 20	9	17	-	-	23	R1	57.0
G1C 40 + R1	40	40	φ 40	-0.039	φ 42	φ 43	1B	8	φ 8	φ 25	10	18	-	-	28	R1	100.0
G1C 50 + R1	50	50	φ 50	-0.048	φ 52	φ 53	1B	8	φ 8	φ 30	10	18	-	-	33	R1	155.0
G1C 60 + R1	60	60	φ 60	-0.058	φ 62	φ 63	2B	8	φ 10	φ 30	10	18	φ 54	4	38	R1	160.0
G1C 80 + R1	80	80	φ 80	-0.078	φ 82	φ 83	2B	8	φ 10	φ 30	10	18	φ 74	4	48	R1	235.0
G1C 100 + R1	100	100	φ 100	-0.098	φ 102	φ 103	2B	8	φ 10	φ 35	10	18	φ 94	4	58	R1	340.0

【+】にはセットスクリューが付いております。【-】: Gear with threaded hole / with set screw.

ウォームホイールの許容トルク (N・m) 歯面強さ

Allowable Transfer Capability Torque of Worm Wheel apply to the rotating speed of Worm only (N・m) as surface durability.

商品記号 Catalogue Numbers	回転速度 (min ⁻¹) revolution/min (Rotating speed of worm)						
	10	20	50	100	150	200	300
G1C 30 + R1	4.909	4.606	4.125	3.773	3.528	3.332	3.057
G1C 40 + R1	8.232	7.859	7.036	6.448	6.076	5.733	5.272
G1C 50 + R1	12.348	11.858	10.682	9.770	9.202	8.761	8.045
G1C 60 + R1	17.052	16.464	14.994	13.720	12.936	12.250	11.368
G1C 80 + R1	28.714	27.636	25.480	23.422	22.050	20.972	19.502
G1C 100 + R1	42.826	41.258	38.612	35.378	33.418	31.850	29.596

ウォーム回転数に対してのウォームホイール許容トルクです。

The above references are JGMA standard.

- 目次 CONTENTS
- インフォメーション INFORMATION
- ギヤボックス GEAR BOXES
- ノーバッキングバックラッシュギヤ ANTI BACKLASH SPUR GEARS
- 齒研平齒車 GROUND SPUR GEARS
- 平齒車 SPUR GEARS
- 内齒車 INTERNAL GEARS
- 齒研ラック GROUND RACKS
- ラック RACKS
- へりかみ・スクリューギヤ HELICAL GEARS AND SCREW GEARS
- ウォーム・ウォームホイール WORMS AND WORM WHEELS
- かさ歯車 BEVEL GEARS
- スプロケット SPROCKETS
- 技術データ REFERENCE DATA

ウォームギヤ

WORMS AND WORM WHEELS

モジュール
MODULE

1.25

圧力角 20° (並歯)

20° PRESSURE ANGLE FULL DEPTH TOOTH

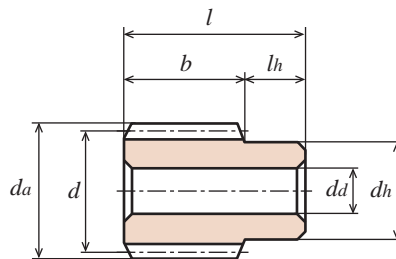

B形
TYPE B

S45C 機械構造用炭素鋼 (JIS G 4051) 精密転造仕上商品です。

Material : Carbon Steel (ISO C45) Precision Cold Rolled processed Worm

単位 : mm
Dimensions : mm

商品記号 Catalogue Number	ねじれ方向 Direction of Thread	条数 Number of Thread z	基準円直径 Reference Diameter d	歯先円直径 Tip Diameter d_a	形 Type	歯幅 Face Width b	穴径 Bore Diameter $d_i(H8)$	ハブ外径 Hub Diameter d_h	ハブ長さ Hub Projection l_h	全長 Overall Length l	進み角 Lead Angle γ	重量 Weight $W(g)$
W1.25S R1 - B	R	1	$\phi 20$	$\phi 22.5$	B	25	$\phi 8$	$\phi 16.8$	12	37	$3^\circ 35'$	65.2

ポリアセタール (白色)

Material : Poly Acetal (White) Dimension X: Coefficient of Rack shift.

単位 : mm
Dimensions : mm

商品記号 Catalogue Number	歯数比 Gear Ratio u	歯数 Number of Teeth z	噛合ピッチ円直径 Pitch Diameter d	転位係数 係数 x	のどの直径 Throat Diameter d_T	歯先円直径 Tip Diameter d_a	形 Type	歯幅 Face Width b	穴径 Bore Diameter d_i	ハブ外径 Hub Diameter d_h	ハブ長さ Hub Projection l_h	全長 Overall Length l	噛合中心距離 Center Distance A	ウォームのねじれ方向及び条数 Hand and Thread for Worm	重量 Weight $W(g)$
G1.25D 20 - R1	20	20	$\phi 25$	-0.020	$\phi 27.5$	$\phi 29.55$	1B	12	$\phi 6$	$\phi 18$	10	22	22.5	R1	11.1
G1.25D 30 - R1	30	30	$\phi 37$	-0.229	$\phi 39.5$	$\phi 41.55$	1B	12	$\phi 8$	$\phi 25$	10	22	28.5	R1	24.0
G1.25D 40 - R1	40	40	$\phi 50$	-0.039	$\phi 52.5$	$\phi 54.55$	1B	12	$\phi 10$	$\phi 35$	10	22	35.0	R1	45.0
G1.25D 50 - R1	50	50	$\phi 63$	0.151	$\phi 65.5$	$\phi 67.55$	1B	12	$\phi 10$	$\phi 35$	10	22	41.5	R1	65.0

ウォームとウォームホイールのねじれ方向及び条数は同じ組み合わせでご利用下さい。

(W : R1 → G : R1) (W : R2 → G : R2)

Engagement of the same number of thread (starts) and hand of thread are important to Worm and Worm Wheel.

Worm: Right hand with single thread
Worm Wheel: Right hand with single thread.



御注文には必ず“フルネームで商品記号”を明記してください。
 Please refer to the catalogue reference while ordering.

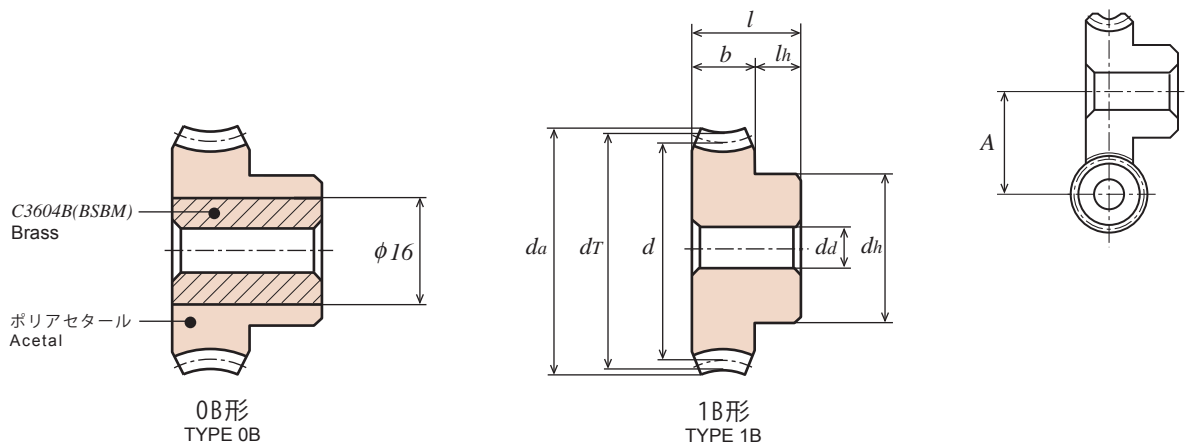

SUS304 ステンレス鋼棒 (JIS G 4303) 精密転造仕上商品です。
 Material : Stainless Steel SUS304 (JIS G 4303) Precision Cold Rolled processed Worm

単位 : mm
 Dimensions : mm

商品記号 Catalogue Number	ねじれ方向 Direction of Thread	条数 Number of Thread z	基準円直径 Reference Diameter d	歯先円直径 Tip Diameter da	形 Type	歯幅 Face Width b	穴径 Bore Diameter da(H8)	ハブ外径 Hub Diameter dh	ハブ長さ Hub Projection lh	全長 Overall Length l	進み角 Lead Angle γ	重量 Weight W(g)
W1.5SU R1 - B	R	1	φ25	φ28	B	30	φ10	φ20	13	43	3°26'	120.0
W1.5SU R2 - B	R	2	φ25	φ28	B	30	φ10	φ20	13	43	6°54'	120.0

ポリアセタール (白色) 黄銅ブッシュ入り (C3604B)
 Material : Poly Acetal (with Brass Bushing) Dimension X: Coefficient of Rack shift.

単位 : mm
 Dimensions : mm

商品記号 Catalogue Number	歯数比 Gear Ratio u	歯数 Number of Teeth z	噛合ピッチ円直径 Pitch Diameter d	転係数 係数 x	のどの直径 Throat Diameter dT	歯先円直径 Tip Diameter da	形 Type	歯幅 Face Width b	穴径 Bore Diameter da	ハブ外径 Hub Diameter dh	ハブ長さ Hub Projection lh	全長 Overall Length l	噛合中心距離 Center Distance A	ウォームのねじれ方向及び条数 Hand and Thread for Worm	重量 Weight W(g)
G1.5DB 20 - R2	10	20	φ30	-0.072	φ33	φ34.3	0B	10	φ8	φ22	10	20	27.5	R2	35.0
G1.5DB 20 - R1	20	20	φ30	-0.018	φ33	φ34.3	0B	10	φ8	φ22	10	20	27.5	R1	35.0

ポリアセタール (白色) ブッシュなし
 Material : Poly Acetal (White) Dimension X: Coefficient of Rack shift.

単位 : mm
 Dimensions : mm

商品記号 Catalogue Number	歯数比 Gear Ratio u	歯数 Number of Teeth z	噛合ピッチ円直径 Pitch Diameter d	転係数 係数 x	のどの直径 Throat Diameter dT	歯先円直径 Tip Diameter da	形 Type	歯幅 Face Width b	穴径 Bore Diameter da	ハブ外径 Hub Diameter dh	ハブ長さ Hub Projection lh	全長 Overall Length l	噛合中心距離 Center Distance A	ウォームのねじれ方向及び条数 Hand and Thread for Worm	重量 Weight W(g)
G1.5D 20 - R2	10	20	φ30	-0.072	φ33	φ35.3	1B	15	φ8	φ25	10	25	27.5	R2	21.0
G1.5D 20 - R1	20	20	φ30	-0.018	φ33	φ35.3	1B	15	φ8	φ25	10	25	27.5	R1	21.0
G1.5D 30 - R2	15	30	φ45	-0.109	φ48	φ50.3	1B	15	φ10	φ30	10	25	35	R2	42.0
G1.5D 30 - R1	30	30	φ45	-0.027	φ48	φ50.3	1B	15	φ10	φ30	10	25	35	R1	42.0
G1.5D 40 - R1	40	40	φ60	-0.036	φ63	φ65.3	1B	15	φ12	φ36	13	28	42.5	R1	75.0
G1.5D 50 - R1	50	50	φ75	-0.045	φ78	φ80.3	1B	15	φ12	φ40	13	28	50	R1	114.0

RoHS 対応

2006年11月生産開始分より欧州 RoHS 指令に対応できる商品を提供しています。
 We supplied the KG-products with RoHS compliance of EU to all our valued customers since November 2006

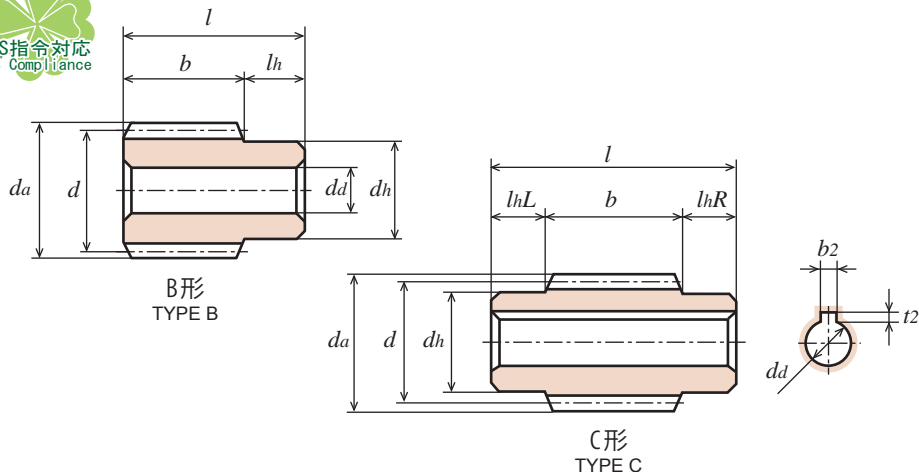

S45C 機械構造用炭素鋼 (JIS G 4051) 精密転造仕上商品です。
Material : Carbon Steel (ISO C45) Precision Cold Rolled processed Worm

単位 : mm
 Dimensions : mm

商品記号 Catalogue Number	ねじれ方向 Direction of Thread	条数 Number of Thread z	基準円直径 Reference Diameter d	歯先円直径 Tip Diameter d_a	形 Type	歯幅 Face Width b	穴径 Bore Diameter $d_a(H8)$	ハブ外径 Hub Diameter d_h	ハブ長さ Hub Projection		全長 Overall Length l	キーみぞ Key Way $b_2 \times t_2$	進み角 Lead Angle γ	重量 Weight $W(kg)$
									lhL	lhR				
W1.5S R1 - B	R	1	$\phi 25$	$\phi 28$	B	30	$\phi 10$	$\phi 20$	-	13	43	-	3°26'	0.12
W1.5S R1 - CF	R	1	$\phi 25$	$\phi 28$	C	35	$\phi 12$	$\phi 20$	10	10	55	-	3°26'	0.14
W1.5S R1 = C	R	1	$\phi 25$	$\phi 28$	C	35	$\phi 12$	$\phi 20$	10	10	55	4 × 1.8	3°26'	0.13
W1.5S R2 - B	R	2	$\phi 25$	$\phi 28$	B	30	$\phi 10$	$\phi 20$	-	13	43	-	6°54'	0.12
W1.5S R2 - CF	R	2	$\phi 25$	$\phi 28$	C	35	$\phi 12$	$\phi 20$	10	10	55	-	6°54'	0.14
W1.5S R2 = C	R	2	$\phi 25$	$\phi 28$	C	35	$\phi 12$	$\phi 20$	10	10	55	4 × 1.8	6°54'	0.13
W1.5S L1 - B	L	1	$\phi 25$	$\phi 28$	B	30	$\phi 10$	$\phi 20$	-	13	43	-	3°26'	0.12
W1.5S L1 = C	L	1	$\phi 25$	$\phi 28$	C	35	$\phi 12$	$\phi 20$	10	10	55	4 × 1.8	3°26'	0.13
W1.5S L2 - B	L	2	$\phi 25$	$\phi 28$	B	30	$\phi 10$	$\phi 20$	-	13	43	-	6°54'	0.12
W1.5S L2 = C	L	2	$\phi 25$	$\phi 28$	C	35	$\phi 12$	$\phi 20$	10	10	55	4 × 1.8	6°54'	0.13

【=】にはキー材が付いております。【=】: Gear with key way / with key.

ウォームとウォームホイールのねじれ方向及び条数は同じ組み合わせでご利用下さい。

(W : R1 → G : R1) (W : L2 → G : L2)

Engagement of the same number of thread (starts) and hand of thread are important to Worm and Worm Wheel.

Worm: Right hand with single thread
 Worm Wheel: Right hand with single thread.

How to identify the left and right hand threads for worm and worm wheel.

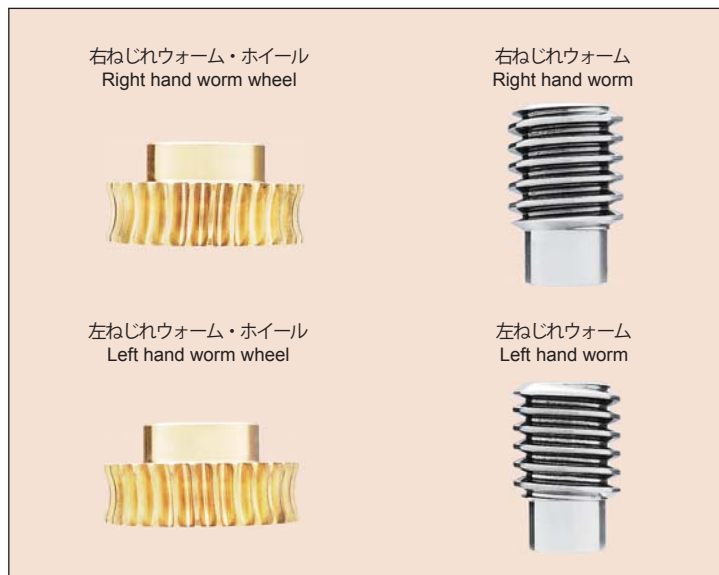



御注文には必ず“フルネームで商品記号”を明記してください。
 Please refer to the catalogue reference while ordering.

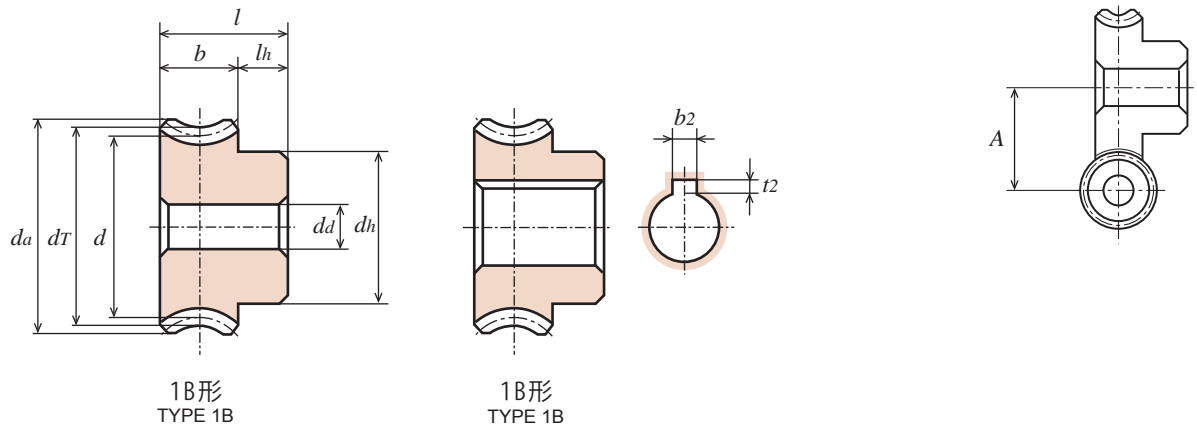

C6191BE アルミニウム青銅、CAC702 アルミニウム青銅鋳物

Material : Aluminum Bronze(JIS C6191BE), Aluminum Bronze Casting (JIS CAC702) Dimension X: Coefficient of Rack shift.

単位 : mm
 Dimensions : mm

商品記号 Catalogue Number	歯数比 Gear Ratio u	歯数 Number of Teeth z	噛み合ピッチ 円直径 Pitch Diameter d	転位 係数 x	のどの 直径 Throat Diameter d _T	歯先円 直径 Tip Diameter d _a	形 Type	歯幅 Face Width b	穴径 Bore Diameter d _a (H8)	ハブ 外径 Hub Diameter d _h	ハブ 長さ Hub Projection l _h	全長 Overall Length l	キー みぞ Key Way b ₂ × t ₂	噛み合中心 距離 Center Distance A	ウォームのねじれ 方向及び条数 Hand and Thread for Worm	重量 Weight W(kg)
G1.5A 20R2 - 8	10	20	φ30	-0.072	φ33	φ35.3	1B	15	φ8	φ25	10	25	-	27.5	R2	0.11
G1.5A 20R2 = 12	10	20	φ30	-0.072	φ33	φ35.3	1B	15	φ12	φ25	10	25	4 × 1.8	27.5	R2	0.10
G1.5A 20R1 - 8	20	20	φ30	-0.018	φ33	φ35.3	1B	15	φ8	φ25	10	25	-	27.5	R1	0.11
G1.5A 20R1 = 12	20	20	φ30	-0.018	φ33	φ35.3	1B	15	φ12	φ25	10	25	4 × 1.8	27.5	R1	0.11
G1.5A 20L2 - 8	10	20	φ30	-0.072	φ33	φ35.3	1B	15	φ8	φ25	10	25	-	27.5	L2	0.11
G1.5A 20L1 - 8	20	20	φ30	-0.018	φ33	φ35.3	1B	15	φ8	φ25	10	25	-	27.5	L1	0.11
G1.5A 30R2 - 10	15	30	φ45	-0.109	φ48	φ50.3	1B	15	φ10	φ30	10	25	-	35	R2	0.23
G1.5A 30R2 = 15	15	30	φ45	-0.109	φ48	φ50.3	1B	15	φ15	φ30	10	25	5 × 2.3	35	R2	0.18
G1.5A 30R1 - 10	30	30	φ45	-0.027	φ48	φ50.3	1B	15	φ10	φ30	10	25	-	35	R1	0.23
G1.5A 30R1 = 15	30	30	φ45	-0.027	φ48	φ50.3	1B	15	φ15	φ30	10	25	5 × 2.3	35	R1	0.18
G1.5A 30L2 - 10	15	30	φ45	-0.109	φ48	φ50.3	1B	15	φ10	φ30	10	25	-	35	L2	0.23
G1.5A 30L1 - 10	30	30	φ45	-0.027	φ48	φ50.3	1B	15	φ10	φ30	10	25	-	35	L1	0.23

[=] にはキー材が付いております。[≠] : Gear with key way / with key.

ウォームホイールの許容トルク (N・m) 歯面強さ

Allowable Transfer Capability Torque of Worm Wheel apply to the rotating speed of Worm only (N・m) as surface durability.

商品記号 Catalogue Numbers	回転速度 (min ⁻¹) revolution/min (Rotating speed of worm)						
	100	250	500	1,000	1,200	1,500	1,800
G1.5A 20R2 - 8	6.801	5.370	4.390	3.498	3.273	3.008	2.802
G1.5A 20R1 - 8	7.036	5.762	4.762	3.851	3.635	3.381	3.185
G1.5A 20L2 - 8	6.801	5.370	4.390	3.498	3.273	3.008	2.802
G1.5A 20L1 - 8	7.036	5.762	4.762	3.851	3.635	3.381	3.185
G1.5A 30R2 - 10	14.700	11.858	9.741	7.830	7.389	6.840	6.409
G1.5A 30R1 - 10	15.092	12.544	10.486	8.545	8.085	7.546	7.114
G1.5A 30L2 - 10	14.700	11.858	9.741	7.830	7.389	6.840	6.409
G1.5A 30L1 - 10	15.092	12.544	10.486	8.545	8.085	7.546	7.114

ウォーム回転数に対するのウォームホイール許容トルクです。

The above references are JGMA standard.

- 目次 CONTENTS
- インフォメーション INFORMATION
- ギヤボックス GEAR BOXES
- ノーバッキングギヤ ANTI BACKLASH SPUR GEARS
- 歯研削歯車 GROUND SPUR GEARS
- 平歯車 SPUR GEARS
- 内歯車 INTERNAL GEARS
- 歯研削歯車 GROUND RACKS
- ラック RACKS
- らせん歯車 HEDICAL GEARS AND SCREW GEARS
- ウォームとウォームホイール WORMS AND WORM WHEELS
- かさ歯車 BEVEL GEARS
- スプロケット SPROCKETS
- 技術データ REFERENCE DATA

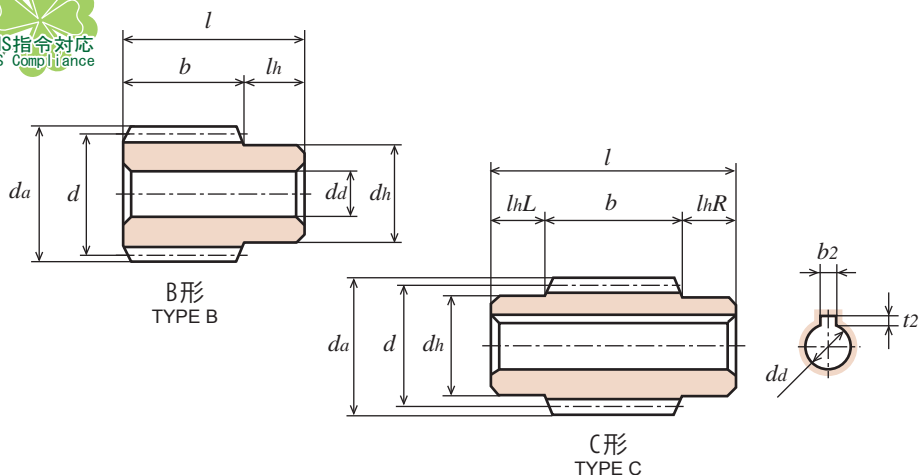

S45C 機械構造用炭素鋼 (JIS G 4051) 精密転造仕上商品です。
Material : Carbon Steel (ISO C45) Precision Cold Rolled processed Worm

単位 : mm
 Dimensions : mm

商品記号 Catalogue Number	ねじれ方向 Direction of Thread	条数 Number of Thread z	基準円直径 Reference Diameter d	歯先円直径 Tip Diameter d_a	形 Type	歯幅 Face Width b	穴径 Bore Diameter $d_a(H8)$	ハブ外径 Hub Diameter d_h	ハブ長さ Hub Projection		全長 Overall Length l	キーみぞ Key Way $b_2 \times t_2$	進み角 Lead Angle γ	重量 Weight $W(kg)$
									l_{hL}	l_{hR}				
W1.5S R1 - B	R	1	$\phi 25$	$\phi 28$	B	30	$\phi 10$	$\phi 20$	-	13	43	-	$3^\circ 26'$	0.12
W1.5S R1 - CF	R	1	$\phi 25$	$\phi 28$	C	35	$\phi 12$	$\phi 20$	10	10	55	-	$3^\circ 26'$	0.14
W1.5S R1 = C	R	1	$\phi 25$	$\phi 28$	C	35	$\phi 12$	$\phi 20$	10	10	55	4×1.8	$3^\circ 26'$	0.13
W1.5S R2 - B	R	2	$\phi 25$	$\phi 28$	B	30	$\phi 10$	$\phi 20$	-	13	43	-	$6^\circ 54'$	0.12
W1.5S R2 - CF	R	2	$\phi 25$	$\phi 28$	C	35	$\phi 12$	$\phi 20$	10	10	55	-	$6^\circ 54'$	0.14
W1.5S R2 = C	R	2	$\phi 25$	$\phi 28$	C	35	$\phi 12$	$\phi 20$	10	10	55	4×1.8	$6^\circ 54'$	0.13
W1.5S L1 - B	L	1	$\phi 25$	$\phi 28$	B	30	$\phi 10$	$\phi 20$	-	13	43	-	$3^\circ 26'$	0.12
W1.5S L1 = C	L	1	$\phi 25$	$\phi 28$	C	35	$\phi 12$	$\phi 20$	10	10	55	4×1.8	$3^\circ 26'$	0.13
W1.5S L2 - B	L	2	$\phi 25$	$\phi 28$	B	30	$\phi 10$	$\phi 20$	-	13	43	-	$6^\circ 54'$	0.12
W1.5S L2 = C	L	2	$\phi 25$	$\phi 28$	C	35	$\phi 12$	$\phi 20$	10	10	55	4×1.8	$6^\circ 54'$	0.13

[=] にはキー材が付いております。 [=]: Gear with key way / with key.



御注文には必ず“フルネームで商品記号”を明記してください。
 Please refer to the catalogue reference while ordering.

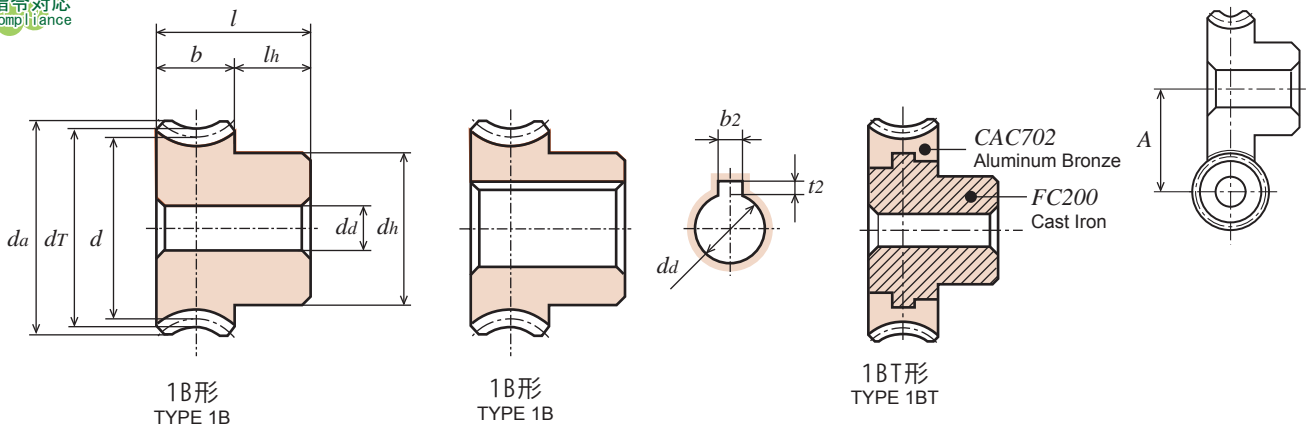

CAC702 アルミニウム青銅鋳物

Material : Aluminum Bronze Casting (JIS CAC702) Dimension X: Coefficient of Rack shift.

単位 : mm
 Dimensions : mm

商品記号 Catalogue Number	歯数比 Gear Ratio <i>u</i>	歯数 Number of Teeth <i>z</i>	噛み合ピッチ 円直径 Pitch Diameter <i>d</i>	転位係数 係数 <i>x</i>	のどの 直径 Throat Diameter <i>d_T</i>	歯先円 直径 Tip Diameter <i>d_a</i>	形 Type	歯幅 Face Width <i>b</i>	穴径 Bore Diameter <i>d_d</i>	ハブ 外径 Hub Diameter <i>d_h</i>	ハブ 長さ Hub Projection <i>l_h</i>	全長 Overall Length <i>l</i>	キー みぞ Key Way <i>b₂ × t₂</i>	噛み合中心 距離 Center Distance <i>A</i>	ウォームのねじれ 方向及び条数 Hand and Thread for Worm	重量 Weight <i>W(kg)</i>
G1.5A 40R2 - 12	20	40	φ60	-0.145	φ63	φ65.3	1BT	15	φ12	φ36	13	28	-	42.5	R2	0.36
G1.5A 40R1 - 12	40	40	φ60	-0.036	φ63	φ65.3	1BT	15	φ12	φ36	13	28	-	42.5	R1	0.36
G1.5A 40R1 = 16	40	40	φ60	-0.036	φ63	φ65.3	1BT	15	φ16	φ36	13	28	5 × 2.3	42.5	R1	0.33
G1.5A 40L2 - 12	20	40	φ60	-0.145	φ63	φ65.3	1BT	15	φ12	φ36	13	28	-	42.5	L2	0.36
G1.5A 40L1 - 12	40	40	φ60	-0.036	φ63	φ65.3	1BT	15	φ12	φ36	13	28	-	42.5	L1	0.36
G1.5A 50R2 - 12	25	50	φ75	-0.181	φ78	φ80.3	1BT	15	φ12	φ40	13	28	-	50	R2	0.53
G1.5A 50R1 - 12	50	50	φ75	-0.045	φ78	φ80.3	1BT	15	φ12	φ40	13	28	-	50	R1	0.53
G1.5A 50R1 = 20	50	50	φ75	-0.045	φ78	φ80.3	1BT	15	φ20	φ40	13	28	6 × 2.8	50	R1	0.48
G1.5A 50L2 - 12	25	50	φ75	-0.181	φ78	φ80.3	1BT	15	φ12	φ40	13	28	-	50	L2	0.53
G1.5A 50L1 - 12	50	50	φ75	-0.045	φ78	φ80.3	1BT	15	φ12	φ40	13	28	-	50	L1	0.53

[=]にはキー材が付いております。[:]: Gear with key way / with key.

ウォームとウォームホイールのねじれ方向及び条数は同じ組み合わせでご使用下さい。

(W : R1 → G : R1) (W : L2 → G : L2)

Engagement of the same number of thread (starts) and hand of thread are important to Worm and Worm Wheel.

Worm: Right hand with single thread
 Worm Wheel: Right hand with single thread.

ウォームホイールの許容トルク (N・m) 歯面強さ

Allowable Transfer Capability Torque of Worm Wheel apply to the rotating speed of Worm only (N・m) as surface durability.

商品記号 Catalogue Numbers	回転速度 (min ⁻¹) revolution/min (Rotating speed of worm)						
	100	250	500	1,000	1,200	1,500	1,800
G1.5A 40R2 - 12	25.284	20.678	17.150	13.818	13.034	12.152	11.466
G1.5A 40R1 - 12	25.774	21.560	18.326	14.994	14.210	13.328	12.544
G1.5A 40L2 - 12	25.284	20.678	17.150	13.818	13.034	12.152	11.466
G1.5A 40L1 - 12	25.774	21.560	18.326	14.994	14.210	13.328	12.544
G1.5A 50R2 - 12	38.612	31.752	26.460	21.462	20.286	18.914	17.836
G1.5A 50R1 - 12	39.004	32.928	28.224	23.226	22.050	20.580	19.502
G1.5A 50L2 - 12	38.612	31.752	26.460	21.462	20.286	18.914	17.836
G1.5A 50L1 - 12	39.004	32.928	28.224	23.226	22.050	20.580	19.502

ウォーム回転数に対してのウォームホイール許容トルクです。

The above references are JGMA standard.

How to identify the left and right hand threads for worm and worm wheel.

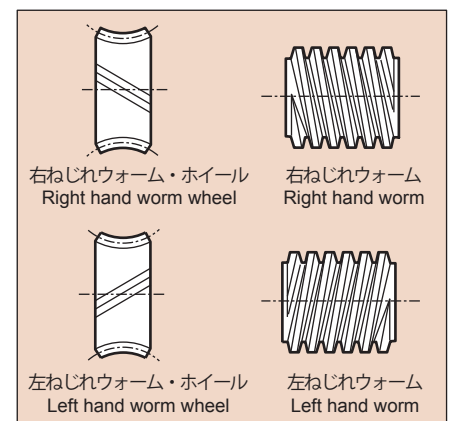

目次 CONTENTS

インフォメーション INFORMATION

ギヤボックス GEAR BOXES

ノーバッキングギヤ ANTI BACKLASH SPUR GEARS

歯研研歯 GROUND SPUR GEARS

平歯車 SPUR GEARS

内歯車 INTERNAL GEARS

歯研研歯 GROUND RACKS

ラック RACKS

ハニカム・スクリューギヤ HELICAL GEARS AND SCREW GEARS

ウォームとウォームホイール WORMS AND WORM WHEELS

かさ歯車 BEVEL GEARS

スプロケット SPROCKETS

技術資料 REFERENCE DATA

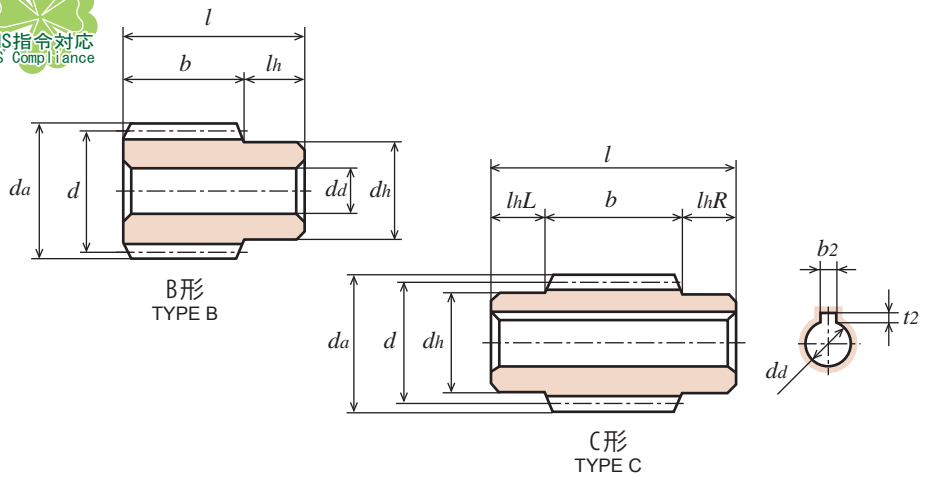

S45C 機械構造用炭素鋼 (JIS G 4051) 精密転造仕上商品です。
Material : Carbon Steel (ISO C45) Precision Cold Rolled processed Worm

単位 : mm
Dimensions : mm

商品記号 Catalogue Number	ねじれ方向 Direction of Thread	条数 Number of Thread z	基準円直径 Reference Diameter d	歯先円直径 Tip Diameter d_a	形 Type	歯幅 Face Width b	穴径 Bore Diameter $d_a(H8)$	ハブ外径 Hub Diameter d_h	ハブ長さ Hub Projection		全長 Overall Length l	キーみぞ Key Way $b_2 \times t_2$	進み角 Lead Angle γ	重量 Weight $W(kg)$
									l_{hL}	l_{hR}				
W1.5S R1 - B	R	1	$\phi 25$	$\phi 28$	B	30	$\phi 10$	$\phi 20$	-	13	43	-	$3^\circ 26'$	0.12
W1.5S R1 - CF	R	1	$\phi 25$	$\phi 28$	C	35	$\phi 12$	$\phi 20$	10	10	55	-	$3^\circ 26'$	0.14
W1.5S R1 = C	R	1	$\phi 25$	$\phi 28$	C	35	$\phi 12$	$\phi 20$	10	10	55	4×1.8	$3^\circ 26'$	0.13
W1.5S R2 - B	R	2	$\phi 25$	$\phi 28$	B	30	$\phi 10$	$\phi 20$	-	13	43	-	$6^\circ 54'$	0.12
W1.5S R2 - CF	R	2	$\phi 25$	$\phi 28$	C	35	$\phi 12$	$\phi 20$	10	10	55	-	$6^\circ 54'$	0.14
W1.5S R2 = C	R	2	$\phi 25$	$\phi 28$	C	35	$\phi 12$	$\phi 20$	10	10	55	4×1.8	$6^\circ 54'$	0.13

[=] にはキー材が付いております。[=]: Gear with key way / with key.

転造加工について

- 素材の塑性変形の原理を利用し、一对の転造ロールの間に材料を置き両側から油圧力により強圧しながら回転させて加工する。
- 材料は、硬度 HB220 以下であれば何でも加工できるが非鉄金属はできない。S45C 以下、S20C 程度が最適。
- ねじピッチ 0.8mm ~ 8mm
- 単体物は外径 $\phi 100$ 、長さ 150 迄。
- ねじの山の型は、自由に設定できる。ねじ、ウォーム、セレーション等。

Regarding the Precision Cold Rolling processed.

With regard to the precision Cold Rolling process of the worm, in respect of theory of plasticity material, the fabrication of the material of Cold Rolled-worm is produced by rotating with hydraulic pressing between both sides of the rolling tooth machine.

For the material of worm without nonferrous metal that can use HB220 or below, S20C to S45C are the most suitable process of the Cold Rolling.

Thread pitch 0.8 to 8.0mm

Our capacity of maximum dimension and length: $\phi 100 \times 150$ mm

It may be possible that this process can make to design of the screw, worm and serration to the free type of thread

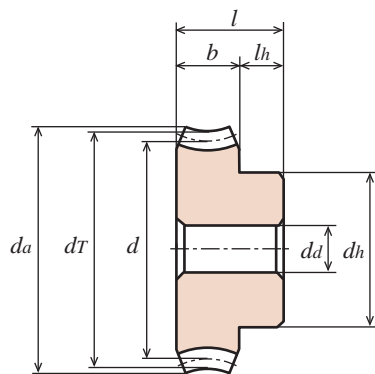

1B形
TYPE 1B

御注文には必ず“フルネームで商品記号”を明記してください。
 Please refer to the catalogue reference while ordering.

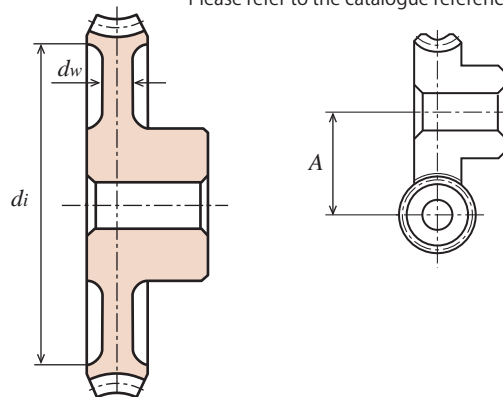

2B形 (3B形はぬき穴付き)
TYPE 2B (Type 3B with Piercing hole)

FC200 ねずみ鋳鉄 (JIS G 5501)

Material : Grey Iron casting (JIS FC200) Dimension X: Coefficient of Rack shift.

単位 : mm
Dimensions : mm

商品記号 Catalogue Number	歯数比 Gear Ratio u	歯数 Number of Teeth z	噛合ピッチ 円直径 Pitch Diameter d	転位 係数 x	のどの 直径 Throat Diameter dT	歯先円 直径 Tip Diameter da	形 Type	歯幅 Face Width b	穴径 Bore Diameter da(H8)	ハブ 外径 Hub Diameter dh	ハブ 長さ Hub Projection lh	全長 Overall Length l	リム 内径 Dimension of Rim di	ウェブ 厚さ Thickness of Web dw	噛合中心 距離 Center Distance A	ウォームのねじれ 方向及び条数 Hand and Thread for Worm	重量 Weight W(kg)
G1.5C 20 - R2	10	20	φ 30	-0.072	φ 33	φ 34.3	1B	10	φ 8	φ 22	10	20	-	-	27.5	R2	0.07
G1.5C 20 - R1	20	20	φ 30	-0.018	φ 33	φ 34.3	1B	10	φ 8	φ 22	10	20	-	-	27.5	R1	0.07
G1.5C 30 - R2	15	30	φ 45	-0.109	φ 48	φ 50	1B	12	φ 10	φ 30	10	22	-	-	35	R2	0.18
G1.5C 30 - R1	30	30	φ 45	-0.027	φ 48	φ 50	1B	12	φ 10	φ 30	10	22	-	-	35	R1	0.18
G1.5C 40 - R1	40	40	φ 60	-0.036	φ 63	φ 65	1B	12	φ 12	φ 36	13	25	-	-	42.5	R1	0.32
G1.5C 50 - R1	50	50	φ 75	-0.045	φ 78	φ 80	1B	14	φ 12	φ 40	13	27	-	-	50	R1	0.54
G1.5C 60 - R1	60	60	φ 90	-0.054	φ 93	φ 96	2B	14	φ 12	φ 40	13	27	φ 81	6	57.5	R1	0.54
G1.5C 80 - R1	80	80	φ 120	-0.072	φ 123	φ 126	2B	14	φ 15	φ 50	15	29	φ 111	6	72.5	R1	0.83
G1.5C 100 - R1	100	100	φ 150	-0.090	φ 153	φ 156	3B	14	φ 15	φ 50	15	29	φ 137	8	87.5	R1	1.19

ウォームとウォームホイールのねじれ方向及び条数は同じ組み合わせでご利用下さい。

(W : R1 → G : R1) (W : R2 → G : R2)

Engagement of the same number of thread (starts) and hand of thread are important to Worm and Worm Wheel.

Worm: Right hand with single thread
 Worm Wheel: Right hand with single thread.

ウォームホイールの許容トルク (N・m) 歯面強さ

Allowable Transfer Capability Torque of Worm Wheel apply to the rotating speed of Worm only (N・m) as surface durability.

商品記号 Catalogue Numbers	回転速度 (min ⁻¹) revolution/min (Rotating speed of worm)						
	10	20	50	100	150	200	300
G1.5C 20 - R2	6.762	6.174	5.448	4.802	4.312	4.018	3.626
G1.5C 20 - R1	6.604	6.174	5.448	4.900	4.508	4.214	3.822
G1.5C 30 - R2	18.032	16.660	14.798	13.230	12.152	11.270	10.094
G1.5C 30 - R1	17.934	16.758	14.994	13.524	12.544	11.858	10.780
G1.5C 40 - R1	30.086	28.616	25.578	23.226	21.560	20.384	18.620
G1.5C 50 - R1	44.982	43.120	38.710	35.084	32.732	31.066	28.420
G1.5C 60 - R1	75.362	72.226	65.464	59.486	55.468	52.626	48.510
G1.5C 80 - R1	126.518	121.128	111.720	101.528	94.668	89.964	83.496
G1.5C 100 - R1	189.042	181.006	169.050	153.664	143.374	136.220	126.518

ウォーム回転数に対するのウォームホイール許容トルクです。

The above references are JGMA standard.

- 目次 CONTENTS
- インフォメーション INFORMATION
- ギヤボックス GEAR BOXES
- ノーバッキングギヤ ANTI BACKLASH SPUR GEARS
- 歯研歯輪 GROUND SPUR GEARS
- 平歯車 SPUR GEARS
- 内歯車 INTERNAL GEARS
- 歯研ラック GROUND RACKS
- ラック RACKS
- へリカル・スクリューギヤ HELICAL GEARS AND SCREW GEARS
- ウォームとウォームホイール WORMS AND WORM WHEELS
- かさね歯車 BEVEL GEARS
- スピロケット SPROCKETS
- 技術資料 REFERENCE DATA

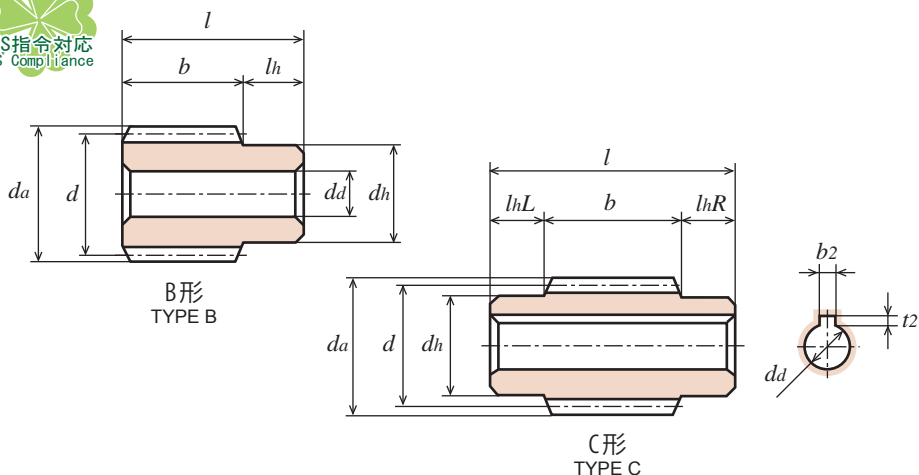

S45C 機械構造用炭素鋼 (JIS G 4051) 精密転造仕上商品です。
Material : Carbon Steel (ISO C45) Precision Cold Rolled processed Worm

単位 : mm
Dimensions : mm

商品記号 Catalogue Number	ねじれ方向 Direction of Thread	条数 Number of Thread z	基準円直径 Reference Diameter d	歯先円直径 Tip Diameter d_a	形 Type	歯幅 Face Width b	穴径 Bore Diameter $d_a(H8)$	ハブ外径 Hub Diameter d_h	ハブ長さ Hub Projection		全長 Overall Length l	キーみぞ Key Way $b_2 \times t_2$	進み角 Lead Angle γ	重量 Weight $W(kg)$
									lhL	lhR				
W2S R1 - B	R	1	$\phi 31$	$\phi 35$	B	35	$\phi 12$	$\phi 25$	-	15	50	-	$3^\circ 42'$	0.22
W2S R1 - CF	R	1	$\phi 31$	$\phi 35$	C	41	$\phi 14$	$\phi 25$	12	12	65	-	$3^\circ 42'$	0.25
W2S R1 = C	R	1	$\phi 31$	$\phi 35$	C	41	$\phi 14$	$\phi 25$	12	12	65	5×2.3	$3^\circ 42'$	0.24
W2S R2 - B	R	2	$\phi 31$	$\phi 35$	B	35	$\phi 12$	$\phi 25$	-	15	50	-	$7^\circ 25'$	0.22
W2S R2 - CF	R	2	$\phi 31$	$\phi 35$	C	41	$\phi 14$	$\phi 25$	12	12	65	-	$7^\circ 25'$	0.25
W2S R2 = C	R	2	$\phi 31$	$\phi 35$	C	41	$\phi 14$	$\phi 25$	12	12	65	5×2.3	$7^\circ 25'$	0.24
W2S L1 - B	L	1	$\phi 31$	$\phi 35$	B	35	$\phi 12$	$\phi 25$	-	15	50	-	$3^\circ 42'$	0.22
W2S L1 = C	L	1	$\phi 31$	$\phi 35$	C	41	$\phi 14$	$\phi 25$	12	12	65	5×2.3	$3^\circ 42'$	0.24
W2S L2 - B	L	2	$\phi 31$	$\phi 35$	B	35	$\phi 12$	$\phi 25$	-	15	50	-	$7^\circ 25'$	0.22
W2S L2 = C	L	2	$\phi 31$	$\phi 35$	C	41	$\phi 14$	$\phi 25$	12	12	65	5×2.3	$7^\circ 25'$	0.24

[=] にはキー材が付いております。 [=]: Gear with key way / with key.

ウォームとウォームホイールのねじれ方向及び条数は同じ組み合わせでご利用下さい。

(W : R1 → G : R1) (W : L2 → G : L2)

Engagement of the same number of thread (starts) and hand of thread are important to Worm and Worm Wheel.

Worm: Right hand with single thread
Worm Wheel: Right hand with single thread.

How to identify the left and right hand threads for worm and worm wheel.

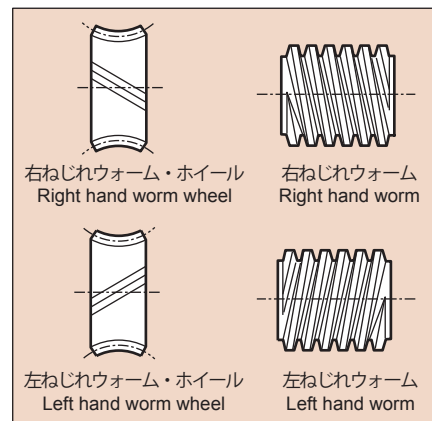

御注文には必ず“フルネームで商品記号”を明記してください。
Please refer to the catalogue reference while ordering.

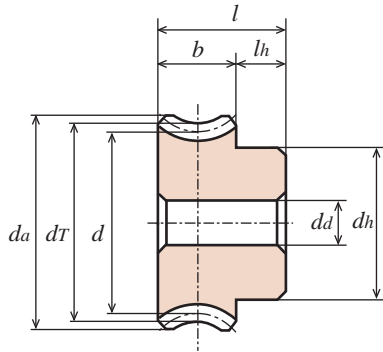

1B形
TYPE 1B

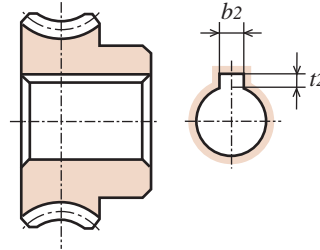

1B形
TYPE 1B

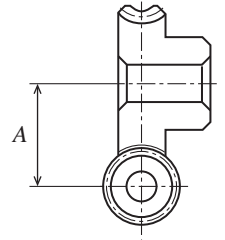

CAC702 アルミニウム青銅鋳物

Material : Aluminum Bronze Casting (JIS CAC702) Dimension X: Coefficient of Rack shift.

単位 : mm
Dimensions : mm

商品記号 Catalogue Number	歯数比 Gear Ratio u	歯数 Number of Teeth z	噛合ピッチ 円直径 Pitch Diameter d	転位 係数 x	のどの 直径 Throat Diameter d _T	歯先円 直径 Tip Diameter d _a	形 Type	歯幅 Face Width b	穴径 Bore Diameter d _a (H8)	ハブ 外径 Hub Diameter d _h	ハブ 長さ Hub Projection l _h	全長 Overall Length l	キー みぞ Key Way b ₂ × t ₂	噛合中心 距離 Center Distance A	ウォームのねじれ 方向及び条数 Hand and Thread for Worm	重量 Weight W(kg)
G2A 20R2 - 10	10	20	φ40	-0.084	φ44	φ47	1B	20	φ10	φ32	15	35	-	35.5	R2	0.26
G2A 20R2 = 15	10	20	φ40	-0.084	φ44	φ47	1B	20	φ15	φ32	15	35	5 × 2.3	35.5	R2	0.23
G2A 20R1 - 10	20	20	φ40	-0.020	φ44	φ47	1B	20	φ10	φ32	15	35	-	35.5	R1	0.26
G2A 20R1 = 15	20	20	φ40	-0.020	φ44	φ47	1B	20	φ15	φ32	15	35	5 × 2.3	35.5	R1	0.23
G2A 20L2 - 10	10	20	φ40	-0.084	φ44	φ47	1B	20	φ10	φ32	15	35	-	35.5	L2	0.26
G2A 20L1 - 10	20	20	φ40	-0.020	φ44	φ47	1B	20	φ10	φ32	15	35	-	35.5	L1	0.26
G2A 25R2 - 12	12.5	25	φ50	-0.105	φ54	φ57	1B	20	φ12	φ38	15	35	-	40.5	R2	0.41
G2A 25R1 - 12	25	25	φ50	-0.026	φ54	φ57	1B	20	φ12	φ38	15	35	-	40.5	R1	0.41
G2A 25L2 - 12	12.5	25	φ50	-0.105	φ54	φ57	1B	20	φ12	φ38	15	35	-	40.5	L2	0.41
G2A 25L1 - 12	25	25	φ50	-0.026	φ54	φ57	1B	20	φ12	φ38	15	35	-	40.5	L1	0.41
G2A 30R2 - 12	15	30	φ60	-0.126	φ64	φ67	1B	20	φ12	φ40	15	35	-	45.5	R2	0.56
G2A 30R2 = 18	15	30	φ60	-0.126	φ64	φ67	1B	20	φ18	φ40	15	35	6 × 2.8	45.5	R2	0.53
G2A 30R1 - 12	30	30	φ60	-0.031	φ64	φ67	1B	20	φ12	φ40	15	35	-	45.5	R1	0.56
G2A 30R1 = 18	30	30	φ60	-0.031	φ64	φ67	1B	20	φ18	φ40	15	35	6 × 2.8	45.5	R1	0.53
G2A 30L2 - 12	15	30	φ60	-0.126	φ64	φ67	1B	20	φ12	φ40	15	35	-	45.5	L2	0.56
G2A 30L1 - 12	30	30	φ60	-0.031	φ64	φ67	1B	20	φ12	φ40	15	35	-	45.5	L1	0.56

[=] にはキー材が付いております。 [=] : Gear with key way / with key.

ウォームホイールの許容トルク (N・m) 歯面強さ

Allowable Transfer Capability Torque of Worm Wheel apply to the rotating speed of Worm only (N・m) as surface durability.

商品記号 Catalogue Numbers	回転速度 (min ⁻¹) revolution/min (Rotating speed of worm)						
	100	250	500	1,000	1,200	1,500	1,800
G2A 20R2 - 10	14.504	11.466	9.310	7.350	6.860	6.370	5.880
G2A 20R1 - 10	12.936	12.250	10.094	8.134	7.644	7.154	6.664
G2A 20L2 - 10	14.504	11.466	9.310	7.350	6.860	6.370	5.880
G2A 20L1 - 10	12.936	12.250	10.094	8.134	7.644	7.154	6.664
G2A 25R2 - 12	22.148	17.640	14.406	11.564	10.878	9.996	9.114
G2A 25R1 - 12	22.932	18.816	15.582	12.642	11.956	11.172	10.486
G2A 25L2 - 12	22.148	17.640	14.406	11.564	10.878	9.996	9.114
G2A 25L1 - 12	22.932	18.816	15.582	12.642	11.956	11.172	10.486
G2A 30R2 - 12	31.262	25.186	20.678	16.562	15.680	14.504	13.524
G2A 30R1 - 12	32.144	26.656	22.246	18.130	17.150	15.974	14.994
G2A 30L2 - 12	31.262	25.186	20.678	16.562	15.680	14.504	13.524
G2A 30L1 - 12	32.144	26.656	22.246	18.130	17.150	15.974	14.994

ウォーム回転数に対するウォームホイール許容トルクです。

The above references are JGMA standard.

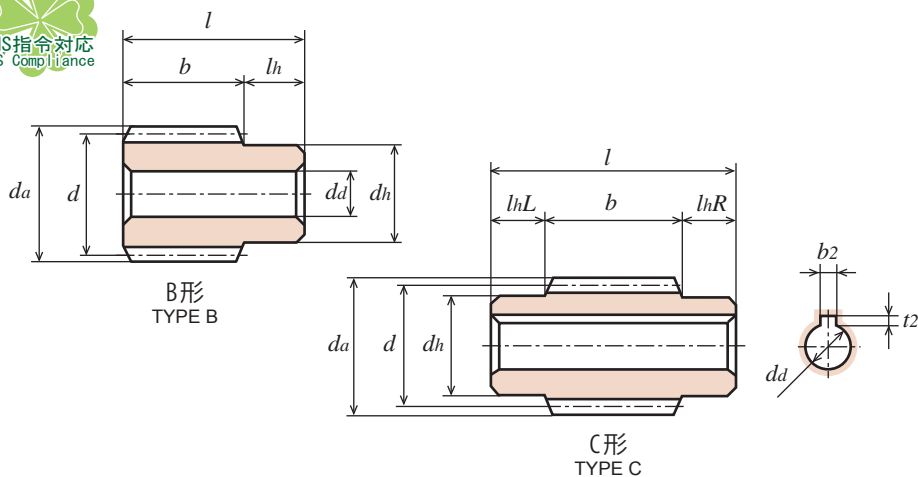

S45C 機械構造用炭素鋼 (JIS G 4051) 精密転造仕上商品です。
Material : Carbon Steel (ISO C45) Precision Cold Rolled processed Worm

単位 : mm
Dimensions : mm

商品記号 Catalogue Number	ねじれ方向 Direction of Thread	条数 Number of Thread <i>z</i>	基準円直径 Reference Diameter <i>d</i>	歯先円直径 Tip Diameter <i>da</i>	形 Type	歯幅 Face Width <i>b</i>	穴径 Bore Diameter <i>da(H8)</i>	ハブ外径 Hub Diameter <i>dh</i>	ハブ長さ Hub Projection		全長 Overall Length <i>l</i>	キーみぞ Key Way <i>b2 × t2</i>	進み角 Lead Angle <i>γ</i>	重量 Weight <i>W(kg)</i>
									<i>lhL</i>	<i>lhR</i>				
W2S R1 - B	R	1	φ31	φ35	B	35	φ12	φ25	-	15	50	-	3°42'	0.22
W2S R1 - CF	R	1	φ31	φ35	C	41	φ14	φ25	12	12	65	-	3°42'	0.25
W2S R1 = C	R	1	φ31	φ35	C	41	φ14	φ25	12	12	65	5 × 2.3	3°42'	0.24
W2S R2 - B	R	2	φ31	φ35	B	35	φ12	φ25	-	15	50	-	7°25'	0.22
W2S R2 - CF	R	2	φ31	φ35	C	41	φ14	φ25	12	12	65	-	7°25'	0.25
W2S R2 = C	R	2	φ31	φ35	C	41	φ14	φ25	12	12	65	5 × 2.3	7°25'	0.24
W2S L1 - B	L	1	φ31	φ35	B	35	φ12	φ25	-	15	50	-	3°42'	0.22
W2S L1 = C	L	1	φ31	φ35	C	41	φ14	φ25	12	12	65	5 × 2.3	3°42'	0.24
W2S L2 - B	L	2	φ31	φ35	B	35	φ12	φ25	-	15	50	-	7°25'	0.22
W2S L2 = C	L	2	φ31	φ35	C	41	φ14	φ25	12	12	65	5 × 2.3	7°25'	0.24

【=】にはキー材が付いております。【=】: Gear with key way / with key.

ウォームとウォームホイールのねじれ方向及び条数は同じ組み合わせでご利用下さい。

(W : R1 → G : R1) (W : L2 → G : L2)

Engagement of the same number of thread (starts) and hand of thread are important to Worm and Worm Wheel.

Worm: Right hand with single thread
Worm Wheel: Right hand with single thread.

How to identify the left and right hand threads for worm and worm wheel.

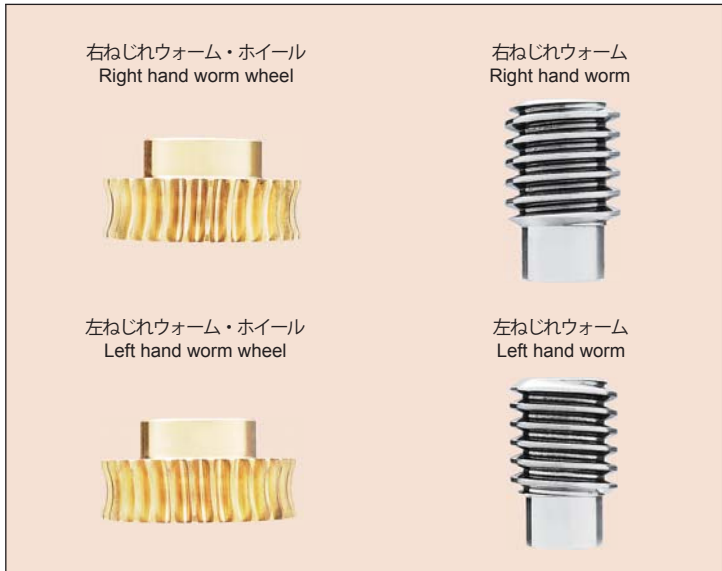



御注文には必ず“フルネームで商品記号”を明記してください。
Please refer to the catalogue reference while ordering.

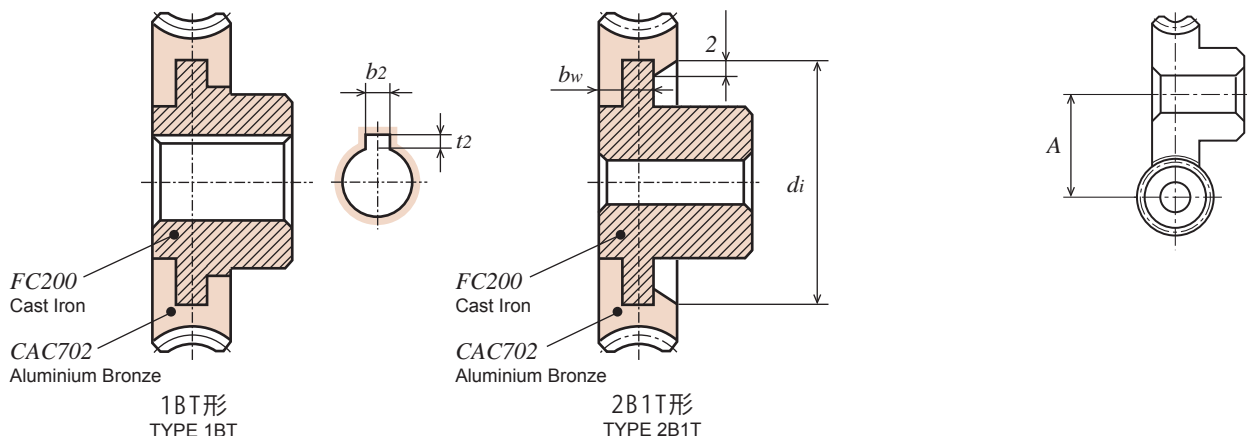

CAC702 アルミニウム青銅鋳物

Material : Aluminum Bronze Casting (JIS CAC702) Dimension X: Coefficient of Rack shift.

単位 : mm
Dimensions : mm

商品記号 Catalogue Number	歯数比 Gear Ratio <i>u</i>	歯数 Number of Teeth <i>z</i>	噛合ピッチ 円直径 Pitch Diameter <i>d</i>	転位係数 係数 <i>x</i>	のどの 直径 Throat Diameter <i>dT</i>	歯先円 直径 Tip Diameter <i>da</i>	形 Type	歯幅 Face Width <i>b</i>	穴径 Bore Diameter <i>da(H8)</i>	ハブ 外径 Hub Diameter <i>dh</i>	ハブ 長さ Hub Projection <i>lh</i>	全長 Overall Length <i>l</i>	キー みぞ Key Way <i>b2 × t2</i>	リム 内径 Dimension of Rim <i>di</i>	ウェブ 厚さ Thickness of Web <i>d_w</i>	噛合中心 距離 Center Distance <i>A</i>	ウォームのねじれ 方向及び条数 Hand and Thread for Worm	重量 Weight <i>W(kg)</i>
G2A 40R2 - 14	20	40	φ 80	-0.168	φ 84	φ 87	1BT	20	φ14	φ45	18	38	-	-	-	55.5	R2	0.92
G2A 40R1 - 14	40	40	φ 80	-0.041	φ 84	φ 87	1BT	20	φ14	φ45	18	38	-	-	-	55.5	R1	0.92
G2A 40R1 = 20	40	40	φ 80	-0.041	φ 84	φ 87	1BT	20	φ20	φ45	18	38	6 × 2.8	-	-	55.5	R1	0.88
G2A 40L2 - 14	20	40	φ 80	-0.168	φ 84	φ 87	1BT	20	φ14	φ45	18	38	-	-	-	55.5	L2	0.92
G2A 40L1 - 14	40	40	φ 80	-0.041	φ 84	φ 87	1BT	20	φ14	φ45	18	38	-	-	-	55.5	L1	0.92
G2A 50R2 - 14	25	50	φ100	-0.210	φ104	φ107	2BT1T	20	φ14	φ50	18	38	-	φ70	15	65.5	R2	1.32
G2A 50R1 - 14	50	50	φ100	-0.052	φ104	φ107	2BT1T	20	φ14	φ50	18	38	-	φ70	15	65.5	R1	1.32
G2A 50R1 = 25	50	50	φ100	-0.052	φ104	φ107	2BT1T	20	φ25	φ50	18	38	8 × 3.3	φ70	15	65.5	R1	1.23
G2A 50L2 - 14	25	50	φ100	-0.210	φ104	φ107	2BT1T	20	φ14	φ50	18	38	-	φ70	15	65.5	L2	1.32
G2A 50L1 - 14	50	50	φ100	-0.052	φ104	φ107	2BT1T	20	φ14	φ50	18	38	-	φ70	15	65.5	L1	1.32

[=]にはキー材が付いております。[-]: Gear with key way / with key.

ウォームとウォームホイールのねじれ方向及び条数は同じ組み合わせでご利用下さい。

(W : R1 → G : R1) (W : L2 → G : L2)

Engagement of the same number of thread (starts) and hand of thread are important to Worm and Worm Wheel.

Worm: Right hand with single thread
Worm Wheel: Right hand with single thread.

ウォームホイールの許容トルク (N・m) 歯面強さ

Allowable Transfer Capability Torque of Worm Wheel apply to the rotating speed of Worm only (N・m) as surface durability.

商品記号 Catalogue Numbers	回転速度 (min ⁻¹) revolution/min (Rotating speed of worm)						
	100	250	500	1,000	1,200	1,500	1,800
G2A 40R2 - 14	53.900	44.002	36.260	29.302	27.636	25.676	24.108
G2A 40R1 - 14	54.978	45.864	38.906	31.850	30.184	28.126	26.558
G2A 40L2 - 14	53.900	44.002	36.260	29.302	27.636	25.676	24.108
G2A 40L1 - 14	54.978	45.864	38.906	31.850	30.184	28.126	26.558
G2A 50R2 - 14	82.222	67.620	56.056	45.472	43.022	39.984	37.632
G2A 50R1 - 14	83.202	69.972	59.780	49.196	46.648	43.610	41.160
G2A 50L2 - 14	82.222	67.620	56.056	45.472	43.022	39.984	37.632
G2A 50L1 - 14	83.202	69.972	59.780	49.196	46.648	43.610	41.160

ウォーム回転数に対するウォームホイール許容トルクです。

The above references are JGMA standard.

目次 CONTENTS

インフォメーション INFORMATION

ギヤボックス GEAR BOXES

ノーバッキングバックラッシュギヤ ANTI BACKLASH SPUR GEAR

歯研削歯車 GROUND SPUR GEARS

平歯車 SPUR GEARS

内歯車 INTERNAL GEARS

歯研削ラック GROUND RACKS

ラック RACKS

へリカル・スクリューギヤ HELICAL GEARS AND SCREW GEARS

ウォームとウォームホイール WORMS AND WORM WHEELS

かさ歯車 BEVEL GEARS

スプロケット SPROCKETS

技術資料 REFERENCE DATA

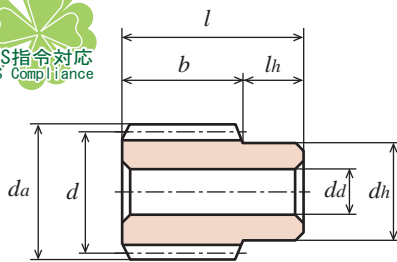

B形
TYPE B

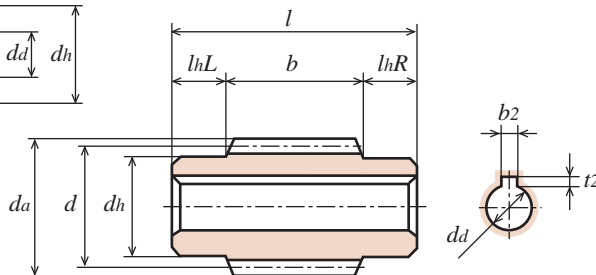

C形
TYPE C

S45C 機械構造用炭素鋼 (JIS G 4051) 精密転造仕上商品です。
Material : Carbon Steel (ISO C45) Precision Cold Rolled processed Worm

単位 : mm
Dimensions : mm

商品記号 Catalogue Number	ねじれ方向 Direction of Thread	条数 Number of Thread z	基準円直径 Reference Diameter d	歯先円直径 Tip Diameter d_a	形 Type	歯幅 Face Width b	穴径 Bore Diameter $d_a(H8)$	ハブ外径 Hub Diameter d_h	ハブ長さ Hub Projection		全長 Overall Length l	キーみぞ Key Way $b_2 \times t_2$	進み角 Lead Angle γ	重量 Weight $W(kg)$
									l_{hL}	l_{hR}				
W2S R1 - B	R	1	$\phi 31$	$\phi 35$	B	35	$\phi 12$	$\phi 25$	-	15	50	-	$3^\circ 42'$	0.22
W2S R1 - CF	R	1	$\phi 31$	$\phi 35$	C	41	$\phi 14$	$\phi 25$	12	12	65	-	$3^\circ 42'$	0.25
W2S R1 = C	R	1	$\phi 31$	$\phi 35$	C	41	$\phi 14$	$\phi 25$	12	12	65	5×2.3	$3^\circ 42'$	0.24
W2S R2 - B	R	2	$\phi 31$	$\phi 35$	B	35	$\phi 12$	$\phi 25$	-	15	50	-	$7^\circ 25'$	0.22
W2S R2 - CF	R	2	$\phi 31$	$\phi 35$	C	41	$\phi 14$	$\phi 25$	12	12	65	-	$7^\circ 25'$	0.25
W2S R2 = C	R	2	$\phi 31$	$\phi 35$	C	41	$\phi 14$	$\phi 25$	12	12	65	5×2.3	$7^\circ 25'$	0.24

[=] にはキー材が付いております。 [=] : Gear with key way / with key.

転造加工について

- 素材の塑性変形の原理を利用し、一对の転造ロールの間に材料を置き両側から油圧力により強圧しながら回転させて加工する。
- 材料は、硬度 HB220 以下であれば何でも加工できるが非鉄金属はできない。S45C 以下、S20C 程度が最適。
- ねじピッチ 0.8mm ~ 8mm
- 単体物は外径 $\phi 100$ 、長さ 150 迄。
- ねじの山の型は、自由に設定できる。ねじ、ウォーム、セレーション等。

Regarding the Precision Cold Rolling processed.

With regard to the precision Cold Rolling process of the worm, in respect of theory of plasticity material, the fabrication of the material of Cold Rolled-worm is produced by rotating with hydraulic pressing between both sides of the rolling tooth machine.

For the material of worm without nonferrous metal that can use HB220 or below, S20C to S45C are the most suitable process of the Cold Rolling.

Thread pitch 0.8 to 8.0mm

Our capacity of maximum dimension and length: $\phi 100 \times 150$ mm

It may be possible that this process can make to design of the screw, worm and serration to the free type of thread

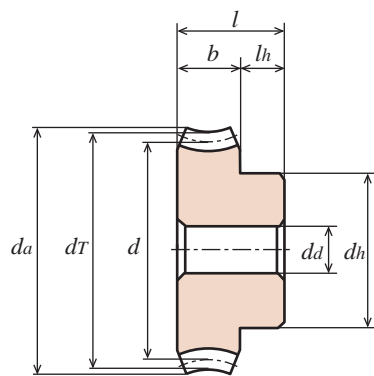

1B形
TYPE 1B

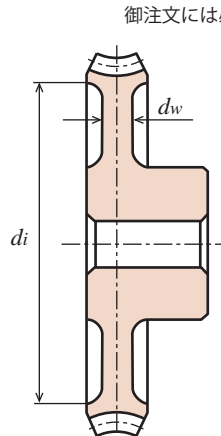

2B形 (3B形はぬき穴付き)
TYPE 2B (Type 3B with Piercing hole)

御注文には必ず“フルネームで商品記号”を明記してください。
Please refer to the catalogue reference while ordering.

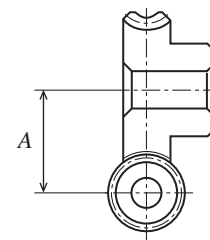

FC200 ねずみ鋳鉄 (JIS G 5501)

Material : Grey Iron casting (JIS FC200) Dimension X: Coefficient of Rack shift.

単位 : mm
Dimensions : mm

商品記号 Catalogue Number	歯数比 Gear Ratio u	歯数 Number of Teeth z	噛合ピッチ 円直径 Pitch Diameter d	転位 係数 x	のどの 直径 Throat Diameter dT	歯先円 直径 Tip Diameter da	形 Type	歯幅 Face Width b	穴径 Bore Diameter da(H8)	ハブ 外径 Hub Diameter dh	ハブ 長さ Hub Projection lh	全長 Overall Length l	リム 内径 Dimension of Rim di	ウェブ 厚さ Thickness of Web dw	噛合中心 距離 Center Distance A	ウォームのねじれ 方向及び条数 Hand and Thread for Worm	重量 Weight W(kg)
G2C 20 - R2	10	20	φ 40	-0.084	φ 44	φ 46.5	1B	16	φ10	φ30	14	30	-	-	35.5	R2	0.20
G2C 20 - R1	20	20	φ 40	-0.020	φ 44	φ 46.5	1B	16	φ10	φ30	14	30	-	-	35.5	R1	0.20
G2C 25 - R1	25	25	φ 50	-0.026	φ 54	φ 57	1B	18	φ12	φ38	15	33	-	-	40.5	R1	0.33
G2C 30 - R2	15	30	φ 60	-0.126	φ 64	φ 67	1B	18	φ12	φ40	15	33	-	-	45.5	R2	0.44
G2C 30 - R1	30	30	φ 60	-0.031	φ 64	φ 67	1B	18	φ12	φ40	15	33	-	-	45.5	R1	0.44
G2C 40 - R1	40	40	φ 80	-0.041	φ 84	φ 88	2B	20	φ14	φ45	18	38	φ 70	8	55.5	R1	0.75
G2C 50 - R1	50	50	φ100	-0.052	φ104	φ108	2B	20	φ14	φ50	18	38	φ 90	8	65.5	R1	1.04
G2C 60 - R1	60	60	φ120	-0.062	φ124	φ128	2B	20	φ14	φ50	18	38	φ110	8	75.5	R1	1.35
G2C 80 - R1	80	80	φ160	-0.083	φ164	φ168	3B	20	φ19	φ54	20	40	φ146	8	95.5	R1	1.82
G2C 100 - R1	100	100	φ200	-0.104	φ204	φ208	3B	20	φ19	φ55	20	40	φ185	8	115.5	R1	2.38

ウォームとウォームホイールのねじれ方向及び条数は同じ組み合わせでご利用下さい。

(W : R1 → G : R1) (W : R2 → G : R2)

Engagement of the same number of thread (starts) and hand of thread are important to Worm and Worm Wheel.

Worm: Right hand with single thread
Worm Wheel: Right hand with single thread.

ウォームホイールの許容トルク (N・m) 歯面強さ

Allowable Transfer Capability Torque of Worm Wheel apply to the rotating speed of Worm only (N・m) as surface durability.

商品記号 Catalogue Numbers	回転速度 (min ⁻¹) revolution/min (Rotating speed of worm)						
	10	20	50	100	150	200	300
G2C 20 - R2	19.600	18.032	15.974	14.014	12.642	11.662	10.486
G2C 20 - R1	19.796	18.228	16.268	14.504	13.328	12.446	11.270
G2C 25 - R1	29.792	27.538	24.598	22.050	20.286	19.110	17.346
G2C 30 - R2	41.650	38.318	34.104	30.086	27.636	25.774	23.030
G2C 30 - R1	41.356	38.710	34.496	30.968	28.616	26.950	24.598
G2C 40 - R1	80.360	76.244	68.110	61.250	56.938	53.606	49.098
G2C 50 - R1	120.050	114.954	103.096	92.708	86.338	81.928	74.872
G2C 60 - R1	166.698	159.544	144.648	130.046	121.128	114.954	105.742
G2C 80 - R1	279.692	267.736	246.764	222.068	206.878	196.392	181.986
G2C 100 - R1	418.068	400.134	373.282	336.140	313.208	297.430	275.772

ウォーム回転数に対するウォームホイール許容トルクです。

The above references are JGMA standard.

目次 CONTENTS

インフォメーション INFORMATION

ギヤボックス GEAR BOXES

ノーバッキングギヤ ANTI BACKLASH SPUR GEARS

歯研歯車 GROUND SPUR GEARS

平歯車 SPUR GEARS

内歯車 INTERNAL GEARS

歯研ラック GROUND RACKS

ラック RACKS

へリカル・スクリューギヤ HELICAL GEARS AND SCREW GEARS

ウォームとウォームホイール WORMS AND WORM WHEELS

かさ歯車 BEVEL GEARS

スプロケット SPROCKETS

技術データ REFERENCE DATA

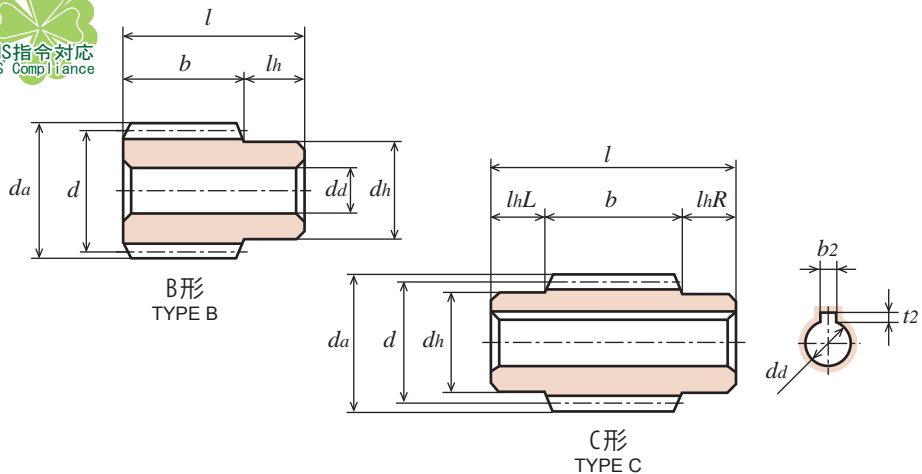

S45C 機械構造用炭素鋼 (JIS G 4051)

Material : Carbon Steel (ISO C45)

単位 : mm
Dimensions : mm

商品記号 Catalogue Number	ねじれ方向 Direction of Thread	条数 Number of Thread z	基準円直径 Reference Diameter d	歯先円直径 Tip Diameter d_a	形 Type	歯幅 Face Width b	穴径 Bore Diameter $d_a(H8)$	ハブ外径 Hub Diameter d_h	ハブ長さ Hub Projection		全長 Overall Length l	キーみぞ Key Way $b_2 \times t_2$	進み角 Lead Angle γ	重量 Weight $W(kg)$
									l_{hL}	l_{hR}				
W2.5S R1 - B	R	1	$\phi 37$	$\phi 42$	B	42	$\phi 14$	$\phi 30$	-	18	60	-	$3^\circ 52'$	0.37
W2.5S R1 - CF	R	1	$\phi 37$	$\phi 42$	C	47	$\phi 16$	$\phi 30$	14	14	75	-	$3^\circ 52'$	0.42
W2.5S R1 = C	R	1	$\phi 37$	$\phi 42$	C	47	$\phi 16$	$\phi 30$	14	14	75	5×2.3	$3^\circ 52'$	0.41
W2.5S R2 - B	R	2	$\phi 37$	$\phi 42$	B	42	$\phi 14$	$\phi 30$	-	18	60	-	$7^\circ 46'$	0.37
W2.5S R2 - CF	R	2	$\phi 37$	$\phi 42$	C	47	$\phi 16$	$\phi 30$	14	14	75	-	$7^\circ 46'$	0.42
W2.5S R2 = C	R	2	$\phi 37$	$\phi 42$	C	47	$\phi 16$	$\phi 30$	14	14	75	5×2.3	$7^\circ 46'$	0.41
W2.5S L1 - B	L	1	$\phi 37$	$\phi 42$	B	42	$\phi 14$	$\phi 30$	-	18	60	-	$3^\circ 52'$	0.37
W2.5S L1 = C	L	1	$\phi 37$	$\phi 42$	C	47	$\phi 16$	$\phi 30$	14	14	75	5×2.3	$3^\circ 52'$	0.41

【=】にはキー材が付いております。【=】: Gear with key way / with key.

ウォームとウォームホイールのねじれ方向及び条数は同じ組み合わせでご利用下さい。
(W : R1 → G : R1) (W : L2 → G : L2)

Engagement of the same number of thread (starts) and hand of thread are important to Worm and Worm Wheel.

Worm: Right hand with single thread
Worm Wheel: Right hand with single thread.

How to identify the left and right hand threads for worm and worm wheel.

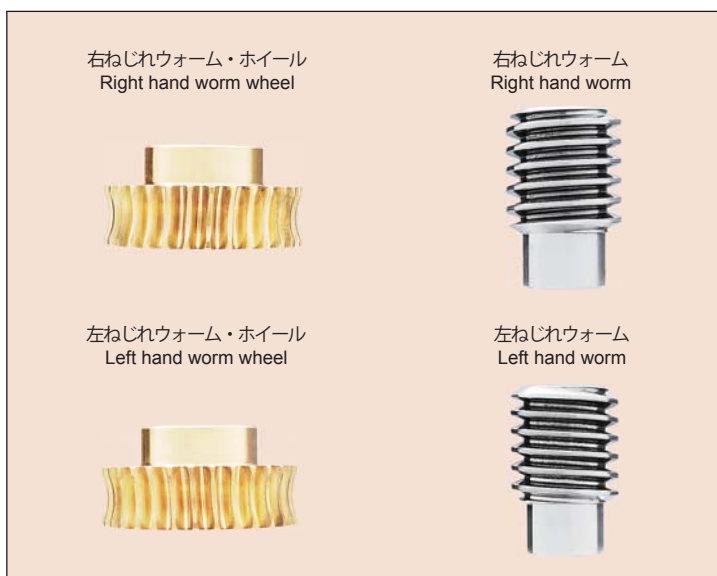



御注文には必ず“フルネームで商品記号”を明記してください。
 Please refer to the catalogue reference while ordering.

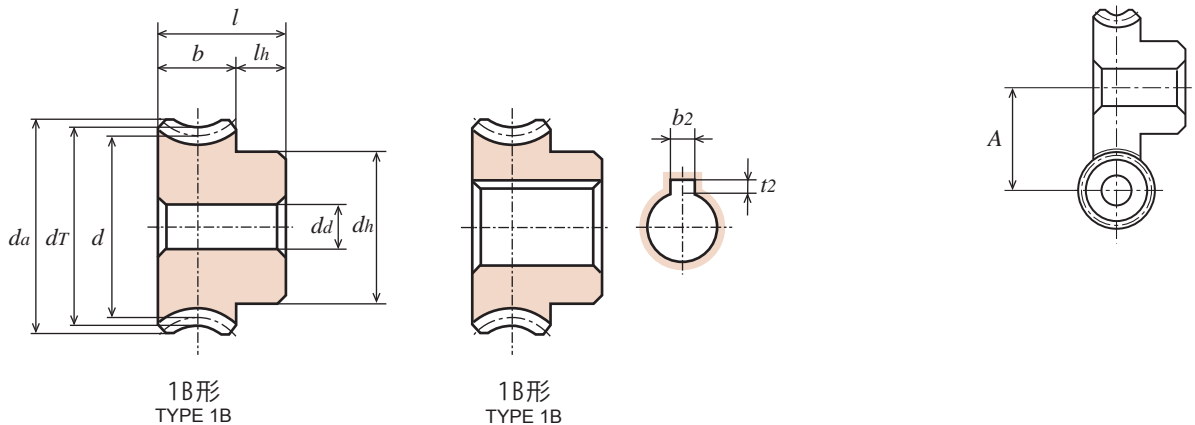

CAC702 アルミニウム青銅鋳物

Material : Aluminum Bronze Casting (JIS CAC702) Dimension X: Coefficient of Rack shift.

単位 : mm
 Dimensions : mm

商品記号 Catalogue Number	歯数比 Gear Ratio u	歯数 Number of Teeth z	噛み合ピッチ 円直径 Pitch Diameter d	転位 係数 x	のどの 直径 Throat Diameter dT	歯先円 直径 Tip Diameter da	形 Type	歯幅 Face Width b	穴径 Bore Diameter da(H8)	ハブ 外径 Hub Diameter dh	ハブ 長さ Hub Projection lh	全長 Overall Length l	キー みぞ Key Way b2 × t2	噛み合中心 距離 Center Distance A	ウォームのねじれ 方向及び条数 Hand and Thread for Worm	重量 Weight W(kg)
G2.5A 20R2 - 12	10	20	φ50	-0.092	φ55	φ58.8	1B	24	φ12	φ40	16	40	-	43.5	R2	0.50
G2.5A 20R2 = 18	10	20	φ50	-0.092	φ55	φ58.8	1B	24	φ18	φ40	16	40	6 × 2.8	43.5	R2	0.46
G2.5A 20R1 - 12	20	20	φ50	-0.022	φ55	φ58.8	1B	24	φ12	φ40	16	40	-	43.5	R1	0.50
G2.5A 20R1 = 18	20	20	φ50	-0.022	φ55	φ58.8	1B	24	φ18	φ40	16	40	6 × 2.8	43.5	R1	0.46
G2.5A 20L1 - 12	20	20	φ50	-0.022	φ55	φ58.8	1B	24	φ12	φ40	16	40	-	43.5	L1	0.50
G2.5A 30R2 - 14	15	30	φ75	-0.138	φ80	φ83.8	1B	24	φ14	φ50	16	40	-	56	R2	1.02
G2.5A 30R2 = 20	15	30	φ75	-0.138	φ80	φ83.8	1B	24	φ20	φ50	16	40	6 × 2.8	56	R2	0.98
G2.5A 30R1 - 14	30	30	φ75	-0.034	φ80	φ83.8	1B	24	φ14	φ50	16	40	-	56	R1	1.02
G2.5A 30R1 = 20	30	30	φ75	-0.034	φ80	φ83.8	1B	24	φ20	φ50	16	40	6 × 2.8	56	R1	0.98
G2.5A 30L1 - 14	30	30	φ75	-0.034	φ80	φ83.8	1B	24	φ14	φ50	16	40	-	56	L1	1.02

[=] にはキー材が付いております。[-]: Gear with key way / with key.

ウォームとウォームホイールのねじれ方向及び条数は同じ組み合わせでご利用下さい。

(W : R1 → G : R1) (W : L2 → G : L2)

Engagement of the same number of thread (starts) and hand of thread are important to Worm and Worm Wheel.

Worm: Right hand with single thread
 Worm Wheel: Right hand with single thread.

ウォームホイールの許容トルク (N・m) 歯面強さ

Allowable Transfer Capability Torque of Worm Wheel apply to the rotating speed of Worm only (N・m) as surface durability.

商品記号 Catalogue Numbers	回転速度 (min ⁻¹) revolution/min (Rotating speed of worm)						
	100	250	500	1,000	1,200	1,500	1,800
G2.5A 20R2 - 12	26.166	20.580	16.758	13.328	12.446	11.368	10.486
G2.5A 20R1 - 12	27.048	22.050	18.130	14.700	13.818	12.838	11.956
G2.5A 20L1 - 12	27.048	22.050	18.130	14.700	13.818	12.838	11.956
G2.5A 30R2 - 14	56.448	45.276	37.142	29.792	28.028	25.970	24.010
G2.5A 30R1 - 14	58.016	47.922	39.984	32.536	30.772	28.616	26.656
G2.5A 30L1 - 14	58.016	47.922	39.984	32.536	30.772	28.616	26.656

ウォーム回転数に対するウォームホイール許容トルクです。

The above references are JGMA standard.

目次 CONTENTS

インフォメーション INFORMATION

ギヤボックス GEAR BOXES

ノーバッキングギヤ ANTI BACKLASH SPUR GEARS

歯研歯車 GROUND SPUR GEARS

平歯車 SPUR GEARS

内歯車 INTERNAL GEARS

歯研ラック GROUND RACKS

ラック RACKS

へリカル・スクリューギヤ HELICAL GEARS AND SCREW GEARS

ウォームとウォームホイール WORMS AND WORM WHEELS

かさ歯車 BEVEL GEARS

スプロケット SPROCKETS

技術資料 REFERENCE DATA

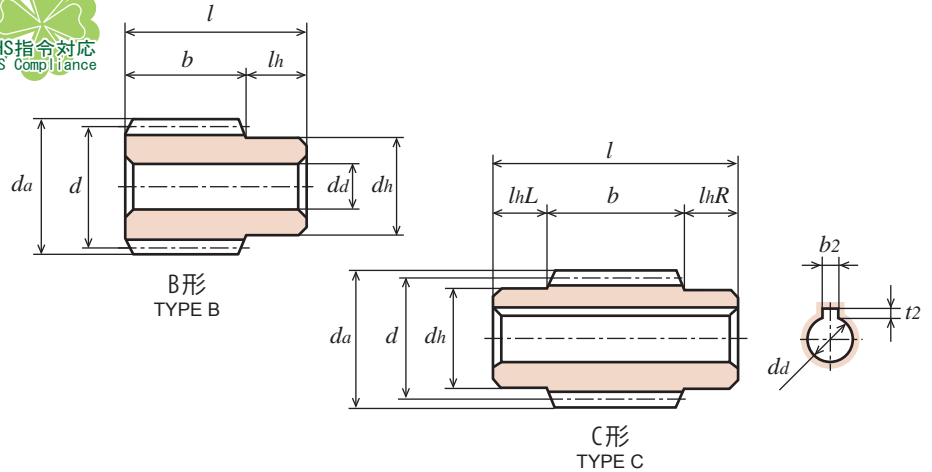

S45C 機械構造用炭素鋼 (JIS G 4051)

Material : Carbon Steel (ISO C45)

単位 : mm
Dimensions : mm

商品記号 Catalogue Number	ねじれ方向 Direction of Thread	条数 Number of Thread z	基準円直径 Reference Diameter d	歯先円直径 Tip Diameter d_a	形 Type	歯幅 Face Width b	穴径 Bore Diameter $d_a(H8)$	ハブ外径 Hub Diameter d_h	ハブ長さ Hub Projection		全長 Overall Length l	キーみぞ Key Way $b_2 \times t_2$	進み角 Lead Angle γ	重量 Weight $W(kg)$
									lhL	lhR				
W2.5S R1 - B	R	1	$\phi 37$	$\phi 42$	B	42	$\phi 14$	$\phi 30$	-	18	60	-	$3^\circ 52'$	0.37
W2.5S R1 - CF	R	1	$\phi 37$	$\phi 42$	C	47	$\phi 16$	$\phi 30$	14	14	75	-	$3^\circ 52'$	0.42
W2.5S R1 = C	R	1	$\phi 37$	$\phi 42$	C	47	$\phi 16$	$\phi 30$	14	14	75	5×2.3	$3^\circ 52'$	0.41
W2.5S R2 - B	R	2	$\phi 37$	$\phi 42$	B	42	$\phi 14$	$\phi 30$	-	18	60	-	$7^\circ 46'$	0.37
W2.5S R2 - CF	R	2	$\phi 37$	$\phi 42$	C	47	$\phi 16$	$\phi 30$	14	14	75	-	$7^\circ 46'$	0.42
W2.5S R2 = C	R	2	$\phi 37$	$\phi 42$	C	47	$\phi 16$	$\phi 30$	14	14	75	5×2.3	$7^\circ 46'$	0.41
W2.5S L1 - B	L	1	$\phi 37$	$\phi 42$	B	42	$\phi 14$	$\phi 30$	-	18	60	-	$3^\circ 52'$	0.37
W2.5S L1 = C	L	1	$\phi 37$	$\phi 42$	C	47	$\phi 16$	$\phi 30$	14	14	75	5×2.3	$3^\circ 52'$	0.41

[=]にはキー材が付いております。[=]: Gear with key way / with key.

ウォームとウォームホイールのねじれ方向及び条数は同じ組み合わせでご利用下さい。

(W : R1 → G : R1) (W : L2 → G : L2)

Engagement of the same number of thread (starts) and hand of thread are important to Worm and Worm Wheel.

Worm: Right hand with single thread
Worm Wheel: Right hand with single thread.

How to identify the left and right hand threads for worm and worm wheel.

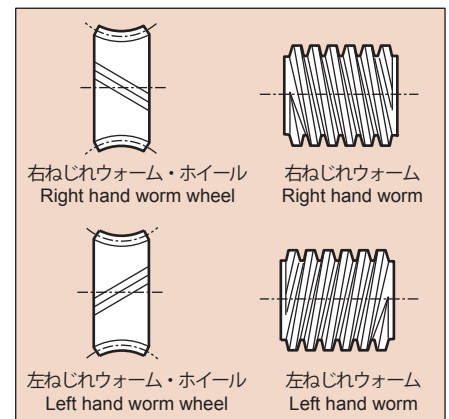



御注文には必ず“フルネームで商品記号”を明記してください。
 Please refer to the catalogue reference while ordering.

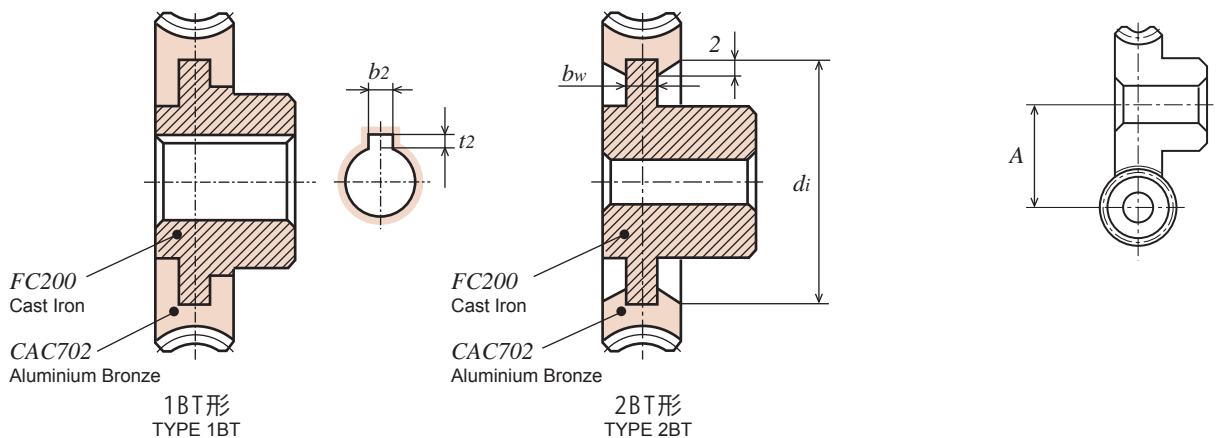

CAC702 アルミニウム青銅鋳物

Material : Aluminum Bronze Casting (JIS CAC702) Dimension X: Coefficient of Rack shift.

単位 : mm
 Dimensions : mm

商品記号 Catalogue Number	歯数比 Gear Ratio <i>u</i>	歯数 Number of Teeth <i>z</i>	噛合ピッチ 円直径 Pitch Diameter <i>d</i>	転位係数 係数 <i>x</i>	のどの直径 Throat Diameter <i>d_T</i>	歯先円直径 Tip Diameter <i>d_a</i>	形 Type	歯幅 Face Width <i>b</i>	穴径 Bore Diameter <i>d_a(H8)</i>	ハブ 外径 Hub Diameter <i>d_h</i>	ハブ 長さ Hub Projection <i>l_h</i>	全長 Overall Length <i>l</i>	キー みぞ Key Way <i>b₂ × t₂</i>	リム 内径 Dimension of Rim <i>d_i</i>	ウェブ 厚さ Thickness of Web <i>d_w</i>	噛合中心 距離 Center Distance <i>A</i>	ウォームのねじれ 方向及び条数 Hand and Thread for Worm	重量 Weight <i>W(kg)</i>
G2.5A 40R2 - 15	20	40	φ100	-0.185	φ105	φ108.8	1BT	24	φ15	φ52	16	40	-	-	-	68.5	R2	1.61
G2.5A 40R1 - 15	40	40	φ100	-0.045	φ105	φ108.8	1BT	24	φ15	φ52	16	40	-	-	-	68.5	R1	1.61
G2.5A 40R1 = 25	40	40	φ100	-0.045	φ105	φ108.8	1BT	24	φ25	φ52	16	40	8 × 3.3	-	-	68.5	R1	1.51
G2.5A 40L1 - 15	40	40	φ100	-0.045	φ105	φ108.8	1BT	24	φ15	φ52	16	40	-	-	-	68.5	L1	1.61
G2.5A 50R2 - 15	25	50	φ125	-0.231	φ130	φ133.8	2BT	24	φ15	φ60	16	40	-	φ90	12	81	R2	2.10
G2.5A 50R1 - 15	50	50	φ125	-0.057	φ130	φ133.8	2BT	24	φ15	φ60	16	40	-	φ90	12	81	R1	2.10
G2.5A 50R1 = 30	50	50	φ125	-0.057	φ130	φ133.8	2BT	24	φ30	φ60	16	40	8 × 3.3	φ90	12	81	R1	1.95
G2.5A 50L1 - 15	50	50	φ125	-0.057	φ130	φ133.8	2BT	24	φ15	φ60	16	40	-	φ90	12	81	L1	2.10

[=] にはキー材が付いております。[=: Gear with key way / with key.

ウォームとウォームホイールのねじれ方向及び条数は同じ組み合わせでご利用下さい。

(W : R1 → G : R1) (W : L2 → G : L2)

Engagement of the same number of thread (starts) and hand of thread are important to Worm and Worm Wheel.

Worm: Right hand with single thread
 Worm Wheel: Right hand with single thread.

ウォームホイールの許容トルク (N・m) 歯面強さ

Allowable Transfer Capability Torque of Worm Wheel apply to the rotating speed of Worm only (N・m) as surface durability.

商品記号 Catalogue Numbers	回転速度 (min ⁻¹) revolution/min (Rotating speed of worm)						
	100	250	500	1,000	1,200	1,500	1,800
G2.5A 40R2 - 15	97.216	79.184	65.170	52.528	49.588	46.060	42.728
G2.5A 40R1 - 15	99.176	82.614	69.874	57.134	54.096	50.372	47.040
G2.5A 40L1 - 15	99.176	82.614	69.874	57.134	54.096	50.372	47.040
G2.5A 50R2 - 15	148.372	121.618	100.646	81.634	77.126	71.638	66.640
G2.5A 50R1 - 15	150.136	126.028	107.408	88.298	83.594	78.008	72.192
G2.5A 50L1 - 15	150.136	126.028	107.408	88.298	83.594	78.008	72.192

ウォーム回転数に対するウォームホイール許容トルクです。

The above references are JGMA standard.

目次 CONTENTS

インフォメーション INFORMATION

ギヤボックス GEAR BOXES

ノーバッキングスピギヤ ANTI BACKLASH SPUR GEAR

歯形ギヤ GROUND SPUR GEARS

平歯車 SPUR GEARS

内歯車 INTERNAL GEARS

歯形ラック GROUND RACKS

ラック RACKS

へリカル・スクリューギヤ HELICAL GEARS AND SCREW GEARS

ウォームとウォームホイール WORMS AND WORM WHEELS

かさ歯車 BEVEL GEARS

スプロケット SPROCKETS

技術資料 REFERENCE DATA

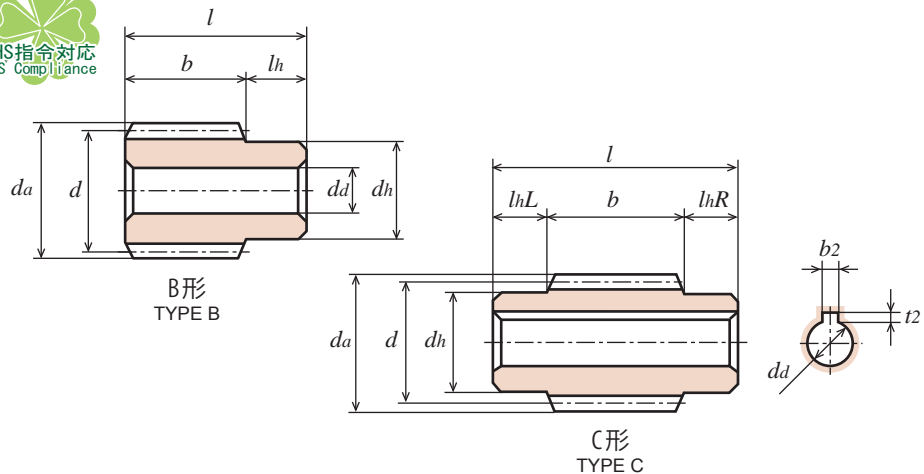

S45C 機械構造用炭素鋼 (JIS G 4051)

Material : Carbon Steel (ISO C45)

単位 : mm
Dimensions : mm

商品記号 Catalogue Number	ねじれ方向 Direction of Thread	条数 Number of Thread z	基準円直径 Reference Diameter d	歯先円直径 Tip Diameter d_a	形 Type	歯幅 Face Width b	穴径 Bore Diameter $d_a(H8)$	ハブ外径 Hub Diameter d_h	ハブ長さ Hub Projection		全長 Overall Length l	キーみぞ Key Way $b_2 \times t_2$	進み角 Lead Angle γ	重量 Weight $W(kg)$
									lhL	lhR				
W3S R1 - B	R	1	$\phi 44$	$\phi 50$	B	50	$\phi 16$	$\phi 36$	-	20	70	-	3°55'	0.62
W3S R1 - CF	R	1	$\phi 44$	$\phi 50$	C	55	$\phi 20$	$\phi 36$	15	15	85	-	3°55'	0.67
W3S R1 = C	R	1	$\phi 44$	$\phi 50$	C	55	$\phi 20$	$\phi 36$	15	15	85	6 × 2.8	3°55'	0.66
W3S R2 - B	R	2	$\phi 44$	$\phi 50$	B	50	$\phi 16$	$\phi 36$	-	20	70	-	7°50'	0.62
W3S R2 - CF	R	2	$\phi 44$	$\phi 50$	C	55	$\phi 20$	$\phi 36$	15	15	85	-	7°50'	0.67
W3S R2 = C	R	2	$\phi 44$	$\phi 50$	C	55	$\phi 20$	$\phi 36$	15	15	85	6 × 2.8	7°50'	0.66
W3S L1 - B	L	1	$\phi 44$	$\phi 50$	B	50	$\phi 16$	$\phi 36$	-	20	70	-	3°55'	0.62
W3S L1 = C	L	1	$\phi 44$	$\phi 50$	C	55	$\phi 20$	$\phi 36$	15	15	85	6 × 2.8	3°55'	0.66

【=】にはキー材が付いております。 [=]: Gear with key way / with key.

ウォームとウォームホイールのねじれ方向及び条数は同じ組み合わせでご利用下さい。
(W : R1 → G : R1) (W : L2 → G : L2)

Engagement of the same number of thread (starts) and hand of thread are important to Worm and Worm Wheel.

Worm: Right hand with single thread
Worm Wheel: Right hand with single thread.

How to identify the left and right hand threads for worm and worm wheel.

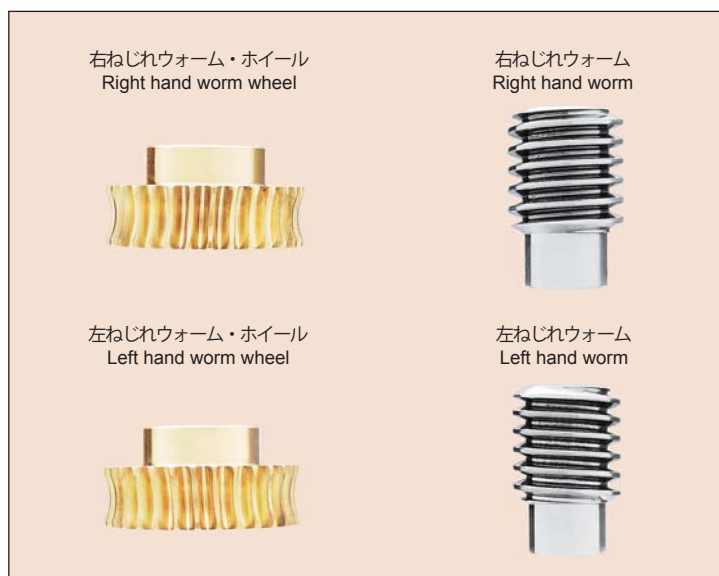



御注文には必ず“フルネームで商品記号”を明記してください。
Please refer to the catalogue reference while ordering.

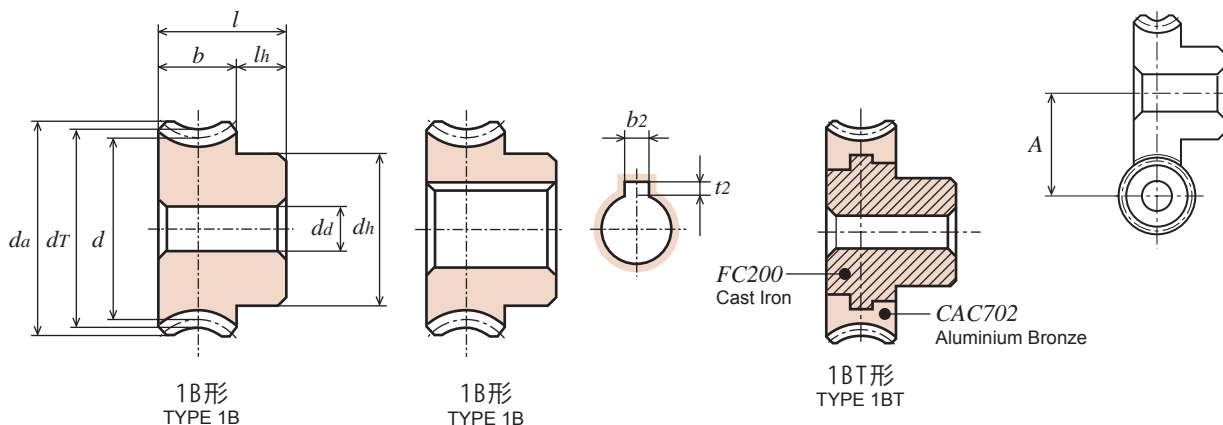

CAC702 アルミニウム青銅鋳物

Material : Aluminum Bronze Casting (JIS CAC702) Dimension X: Coefficient of Rack shift.

単位 : mm
Dimensions : mm

商品記号 Catalogue Number	歯数比 Gear Ratio u	歯数 Number of Teeth z	噛み合ピッチ 円直径 Pitch Diameter d	転位係数 係数 x	のどの直径 Throat Diameter dT	歯先円直径 Tip Diameter da	形 Type	歯幅 Face Width b	穴径 Bore Diameter da(H8)	ハブ 外径 Hub Diameter dh	ハブ 長さ Hub Projection lh	全長 Overall Length l	キー みぞ Key Way b2 × t2	噛み合中心 距離 Center Distance A	ウォームのねじれ 方向及び条数 Hand and Thread for Worm	重量 Weight W(kg)
G3A 20R2 - 16	10	20	φ60	-0.094	φ66	φ 70.5	1B	28	φ16	φ48	17	45	-	52	R2	0.80
G3A 20R2 = 20	10	20	φ60	-0.094	φ66	φ 70.5	1B	28	φ20	φ48	17	45	6 × 2.8	52	R2	0.77
G3A 20R1 - 16	20	20	φ60	-0.023	φ66	φ 70.5	1B	28	φ16	φ48	17	45	-	52	R1	0.80
G3A 20R1 = 20	20	20	φ60	-0.023	φ66	φ 70.5	1B	28	φ20	φ48	17	45	6 × 2.8	52	R1	0.77
G3A 20L1 - 16	20	20	φ60	-0.023	φ66	φ 70.5	1B	28	φ16	φ48	17	45	-	52	L1	0.80
G3A 25R2 - 16	12.5	25	φ75	-0.117	φ81	φ 85.5	1B	28	φ16	φ55	17	45	-	59.5	R2	1.22
G3A 25R1 - 16	25	25	φ75	-0.029	φ81	φ 85.5	1B	28	φ16	φ55	17	45	-	59.5	R1	1.22
G3A 25L1 - 16	25	25	φ75	-0.029	φ81	φ 85.5	1B	28	φ16	φ55	17	45	-	59.5	L1	1.22
G3A 30R2 - 16	15	30	φ90	-0.141	φ96	φ 100.5	1BT	28	φ16	φ55	17	45	-	67	R2	1.59
G3A 30R2 = 25	15	30	φ90	-0.141	φ96	φ 100.5	1BT	28	φ25	φ55	17	45	8 × 3.3	67	R2	1.51
G3A 30R1 - 16	30	30	φ90	-0.034	φ96	φ 100.5	1BT	28	φ16	φ55	17	45	-	67	R1	1.59
G3A 30R1 = 25	30	30	φ90	-0.034	φ96	φ 100.5	1BT	28	φ25	φ55	17	45	8 × 3.3	67	R1	1.51
G3A 30L1 - 16	30	30	φ90	-0.034	φ96	φ 100.5	1BT	28	φ16	φ55	17	45	-	67	L1	1.59

[=]にはキー材が付いております。[-]: Gear with key way / with key.

ウォームホイールの許容トルク (N・m) 歯面強さ

Allowable Transfer Capability Torque of Worm Wheel apply to the rotating speed of Worm only (N・m) as surface durability.

商品記号 Catalogue Numbers	回転速度 (min ⁻¹) revolution/min (Rotating speed of worm)						
	100	250	500	1,000	1,200	1,500	1,800
G3A 20R2 - 16	42.532	33.418	26.950	21.560	20.188	18.228	16.758
G3A 20R1 - 16	44.100	35.868	29.302	23.716	22.344	20.580	19.012
G3A 20L1 - 16	44.100	35.868	29.302	23.716	22.344	20.580	19.012
G3A 25R2 - 16	64.974	51.548	41.846	33.614	31.556	28.714	26.460
G3A 25R1 - 16	67.326	55.076	45.276	36.848	34.790	31.948	29.694
G3A 25L1 - 16	67.326	55.076	45.276	36.848	34.790	31.948	29.694
G3A 30R2 - 16	91.826	73.598	59.878	48.314	45.374	41.552	38.318
G3A 30R1 - 16	94.472	77.812	64.582	52.724	49.784	45.766	42.532
G3A 30L1 - 16	94.472	77.812	64.582	52.724	49.784	45.766	42.532

ウォーム回転数に対してのウォームホイール許容トルクです。

The above references are JGMA standard.

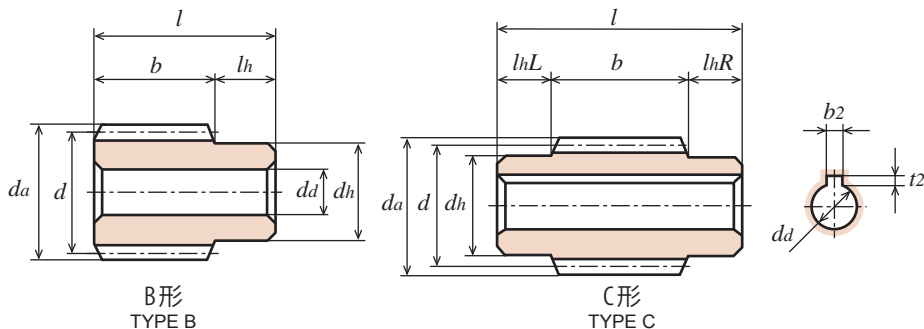

S45C 機械構造用炭素鋼 (JIS G 4051)

Material : Carbon Steel (ISO C45)

単位 : mm
Dimensions : mm

商品記号 Catalogue Number	ねじれ方向 Direction of Thread	条数 Number of Thread	基準円直径 Reference Diameter	歯先円直径 Tip Diameter	形 Type	歯幅 Face Width	穴径 Bore Diameter	ハブ外径 Hub Diameter	ハブ長さ Hub Projection		全長 Overall Length	キーみぞ Key Way	進み角 Lead Angle	重量 Weight
									lhL	lhR				
W3S R1 - B	R	1	φ44	φ50	B	50	φ16	φ36	-	20	70	-	3°55'	0.62
W3S R1 - CF	R	1	φ44	φ50	C	55	φ20	φ36	15	15	85	-	3°55'	0.67
W3S R1 = C	R	1	φ44	φ50	C	55	φ20	φ36	15	15	85	6 × 2.8	3°55'	0.66
W3S R2 - B	R	2	φ44	φ50	B	50	φ16	φ36	-	20	70	-	7°50'	0.62
W3S R2 - CF	R	2	φ44	φ50	C	55	φ20	φ36	15	15	85	-	7°50'	0.67
W3S R2 = C	R	2	φ44	φ50	C	55	φ20	φ36	15	15	85	6 × 2.8	7°50'	0.66
W3S L1 - B	L	1	φ44	φ50	B	50	φ16	φ36	-	20	70	-	3°55'	0.62
W3S L1 = C	L	1	φ44	φ50	C	55	φ20	φ36	15	15	85	6 × 2.8	3°55'	0.66

[=]にはキー材が付いております。[=]: Gear with key way / with key.

ウォームとウォームホイールのねじれ方向及び条数は同じ組み合わせでご利用下さい。

(W : R1 → G : R1) (W : L2 → G : L2)

Engagement of the same number of thread (starts) and hand of thread are important to Worm and Worm Wheel.

Worm: Right hand with single thread
Worm Wheel: Right hand with single thread.

How to identify the left and right hand threads for worm and worm wheel.

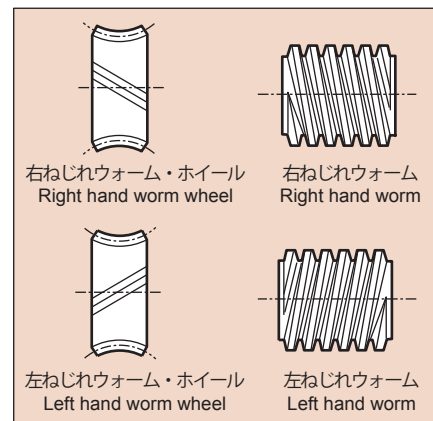



御注文には必ず“フルネームで商品記号”を明記してください。
Please refer to the catalogue reference while ordering.

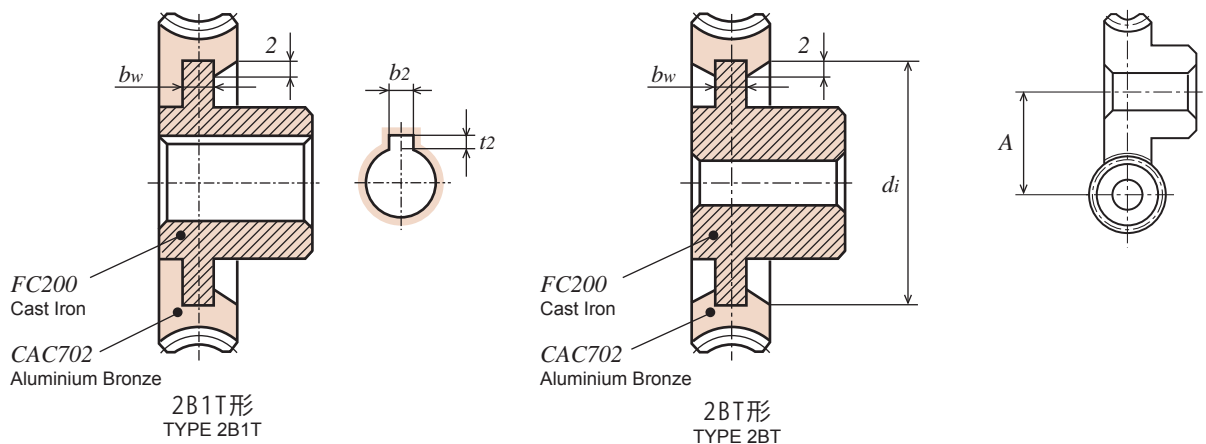

CAC702 アルミニウム青銅鋳物

Material : Aluminum Bronze Casting (JIS CAC702) Dimension X: Coefficient of Rack shift.

単位 : mm
Dimensions : mm

商品記号 Catalogue Number	歯数比 Gear Ratio <i>u</i>	歯数 Number of Teeth <i>z</i>	歯ピッチ 円直径 Pitch Diameter <i>d</i>	転位係数 <i>x</i>	のどの直径 Throat Diameter <i>dt</i>	歯先円直径 Tip Diameter <i>da</i>	形 Type	歯幅 Face Width <i>b</i>	穴径 Bore Diameter <i>da(H8)</i>	ハブ外径 Hub Diameter <i>dh</i>	ハブ長さ Hub Projection <i>lh</i>	全長 Overall Length <i>l</i>	キヤミぞ Key Way <i>b2 × t2</i>	リム内径 Dimension of Rim <i>di</i>	ウェブ厚さ Thickness of Web <i>dw</i>	噛合中心距離 Center Distance <i>A</i>	ウォームのねじれ方向及び条数 Hand and Thread for Worm	重量 Weight <i>W(kg)</i>
G3A 40R2 - 16	20	40	φ120	-0.188	φ126	φ130.5	2B1T	28	φ16	φ60	20	48	-	φ86	20	82	R2	2.50
G3A 40R1 - 16	40	40	φ120	-0.046	φ126	φ130.5	2B1T	28	φ16	φ60	20	48	-	φ86	20	82	R1	2.50
G3A 40R1 = 30	40	40	φ120	-0.046	φ126	φ130.5	2B1T	28	φ30	φ60	20	48	8 × 3.3	φ86	20	82	R1	2.32
G3A 40L1 - 16	40	40	φ120	-0.046	φ126	φ130.5	2B1T	28	φ16	φ60	20	48	-	φ86	20	82	L1	2.50
G3A 50R2 - 16	25	50	φ150	-0.235	φ156	φ160.5	2BT	28	φ16	φ70	20	48	-	φ108	12	97	R2	3.60
G3A 50R1 - 16	50	50	φ150	-0.058	φ156	φ160.5	2BT	28	φ16	φ70	20	48	-	φ108	12	97	R1	3.60
G3A 50R1 = 40	50	50	φ150	-0.058	φ156	φ160.5	2BT	28	φ40	φ70	20	48	12 × 3.3	φ108	12	97	R1	3.17
G3A 50L1 - 16	50	50	φ150	-0.058	φ156	φ160.5	2BT	28	φ16	φ70	20	48	-	φ108	12	97	L1	3.60

[=]にはキー材が付いております。 [=]: Gear with key way / with key.

ウォームとウォームホイールのねじれ方向及び条数は同じ組み合わせでご使用下さい。

(W : R1 → G : R1) (W : L2 → G : L2)

Engagement of the same number of thread (starts) and hand of thread are important to Worm and Worm Wheel.

Worm: Right hand with single thread

Worm Wheel: Right hand with single thread.

ウォームホイールの許容トルク (N・m) 歯面強さ

Allowable Transfer Capability Torque of Worm Wheel apply to the rotating speed of Worm only (N・m) as surface durability.

商品記号 Catalogue Numbers	回転速度 (min ⁻¹) revolution/min (Rotating speed of worm)						
	100	250	500	1,000	1,200	1,500	1,800
G3A 40R2 - 16	158.270	128.576	105.154	85.260	80.262	73.696	68.306
G3A 40R1 - 16	161.406	134.162	112.896	92.512	87.416	80.654	75.068
G3A 40L1 - 16	161.406	134.162	112.896	92.512	87.416	80.654	75.068
G3A 50R2 - 16	241.570	197.568	162.582	132.202	124.754	114.660	106.428
G3A 50R1 - 16	244.412	204.624	173.460	142.982	135.338	124.950	116.424
G3A 50L1 - 16	244.412	204.624	173.460	142.982	135.338	124.950	116.424

ウォーム回転数に対するウォームホイール許容トルクです。

The above references are JGMA standard.

目次 CONTENTS

インフォメーション INFORMATION

ギヤボックス GEAR BOXES

ノーバッキングスピギヤ ANTI BACKLASH SPUR GEAR

歯研平歯車 GROUND SPUR GEARS

平歯車 SPUR GEARS

内歯車 INTERNAL GEARS

歯研ラック GROUND RACKS

ラック RACKS

へリカル・スクリューギヤ HELICAL GEARS AND SCREW GEARS

ウォームとウォームホイール WORMS AND WORM WHEELS

かさ歯車 BEVEL GEARS

スプロケット SPROCKETS

技術データ REFERENCE DATA

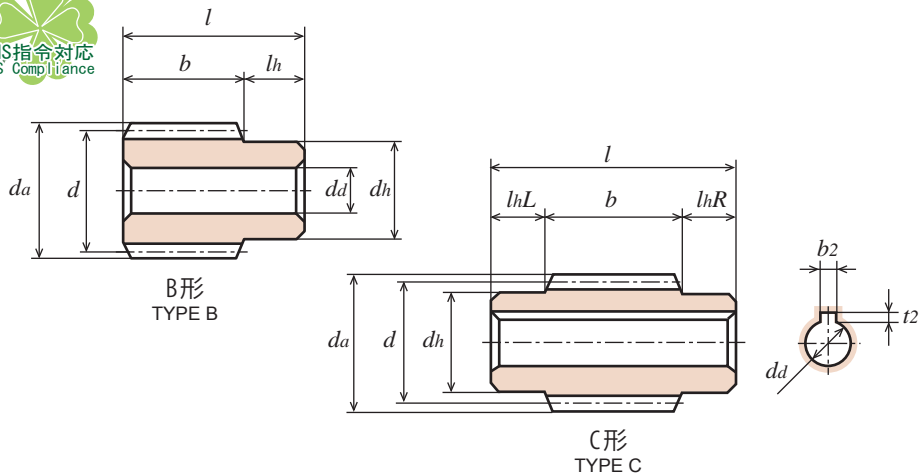

S45C 機械構造用炭素鋼 (JIS G 4051)

Material : Carbon Steel (ISO C45)

単位 : mm
Dimensions : mm

商品記号 Catalogue Number	ねじれ方向 Direction of Thread	条数 Number of Thread z	基準円直径 Reference Diameter d	歯先円直径 Tip Diameter d_a	形 Type	歯幅 Face Width b	穴径 Bore Diameter $d_a(H8)$	ハブ外径 Hub Diameter d_h	ハブ長さ Hub Projection		全長 Overall Length l	キーみぞ Key Way $b_2 \times t_2$	進み角 Lead Angle γ	重量 Weight $W(kg)$
									l_{hL}	l_{hR}				
W3S R1 - B	R	1	$\phi 44$	$\phi 50$	B	50	$\phi 16$	$\phi 36$	-	20	70	-	$3^\circ 55'$	0.62
W3S R1 - CF	R	1	$\phi 44$	$\phi 50$	C	55	$\phi 20$	$\phi 36$	15	15	85	-	$3^\circ 55'$	0.67
W3S R1 = C	R	1	$\phi 44$	$\phi 50$	C	55	$\phi 20$	$\phi 36$	15	15	85	6×2.8	$3^\circ 55'$	0.66
W3S R2 - B	R	2	$\phi 44$	$\phi 50$	B	50	$\phi 16$	$\phi 36$	-	20	70	-	$7^\circ 50'$	0.62
W3S R2 - CF	R	2	$\phi 44$	$\phi 50$	C	55	$\phi 20$	$\phi 36$	15	15	85	-	$7^\circ 50'$	0.67
W3S R2 = C	R	2	$\phi 44$	$\phi 50$	C	55	$\phi 20$	$\phi 36$	15	15	85	6×2.8	$7^\circ 50'$	0.66

【=】にはキー材が付いております。

【=】: Gear with key way / with key.

ウォームとウォームホイールのねじれ方向及び条数は同じ組み合わせでご使用下さい。

(W : R1 → G : R1) (W : R2 → G : R2)

Engagement of the same number of thread (starts) and hand of thread are important to Worm and Worm Wheel.

Worm: Right hand with single thread
Worm Wheel: Right hand with single thread.

How to identify the left and right hand threads for worm and worm wheel.

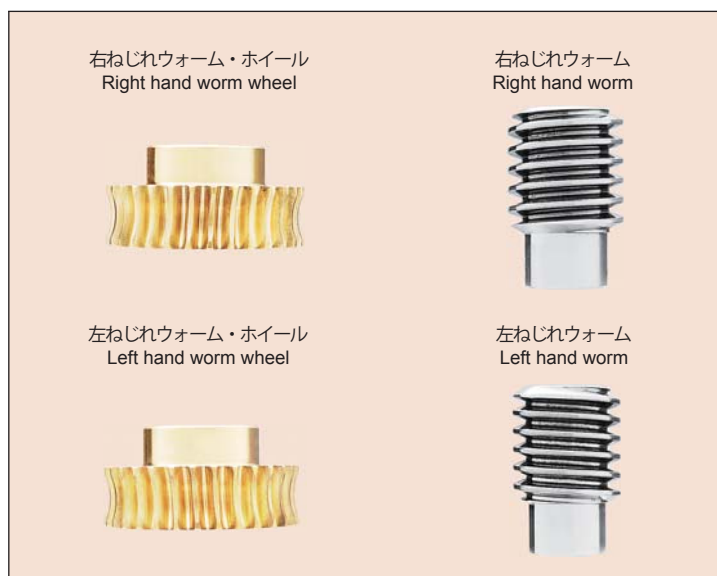

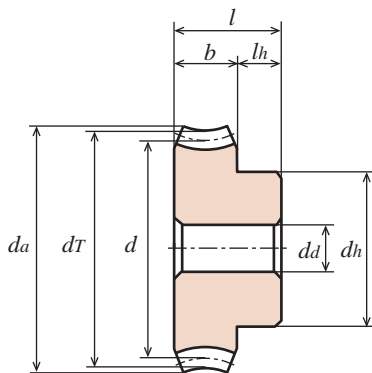

1B形
TYPE 1B

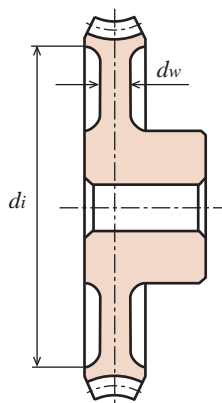

2B形
TYPE 2B

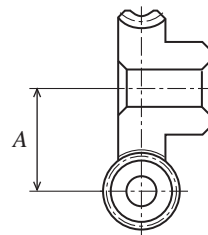

御注文には必ず“フルネームで商品記号”を明記してください。
Please refer to the catalogue reference while ordering.

FC200 ねずみ鋳鉄 (JIS G 5501)

Material : Grey Iron casting (JIS FC200) Dimension X: Coefficient of Rack shift.

単位 : mm
Dimensions : mm

商品記号 Catalogue Number	歯数比 Gear Ratio u	歯数 Number of Teeth z	歯ピッチ 円直径 Pitch Diameter d	転位係数 x	のどの直径 Throat Diameter dT	歯先円直径 Tip Diameter da	形 Type	歯幅 Face Width b	穴径 Bore Diameter da(H8)	ハブ外径 Hub Diameter dh	ハブ長さ Hub Projection lh	全長 Overall Length l	リム内径 Dimension of Rim di	ウェブ厚さ Thickness of Web dw	歯合中心距離 Center Distance A	ウォームのねじれ 方向及び条数 Hand and Thread for Worm	重量 Weight W(kg)
G3C 20 - R2	10	20	φ 60	-0.094	φ 66	φ 70	1B	24	φ16	φ48	18	42	-	-	52	R2	0.65
G3C 20 - R1	20	20	φ 60	-0.023	φ 66	φ 70	1B	24	φ16	φ48	18	42	-	-	52	R1	0.65
G3C 25 - R1	25	25	φ 75	-0.029	φ 81	φ 85	1B	24	φ16	φ55	18	42	-	-	59.5	R1	1.02
G3C 30 - R2	15	30	φ 90	-0.141	φ 96	φ 100	1B	24	φ16	φ55	18	42	-	-	67	R2	1.36
G3C 30 - R1	30	30	φ 90	-0.034	φ 96	φ 100	1B	24	φ16	φ55	18	42	-	-	67	R1	1.36
G3C 40 - R1	40	40	φ 120	-0.046	φ 126	φ 131	2B	28	φ16	φ60	20	48	φ106	8	82	R1	1.88

ウォームとウォームホイールのねじれ方向及び条数は同じ組み合わせでご利用下さい。

(W : R1 → G : R1) (W : R2 → G : R2)

Engagement of the same number of thread (starts) and hand of thread are important to Worm and Worm Wheel.

Worm: Right hand with single thread
Worm Wheel: Right hand with single thread.

ウォームホイールの許容トルク (N・m) 歯面強さ

Allowable Transfer Capability Torque of Worm Wheel apply to the rotating speed of Worm only (N・m) as surface durability.

商品記号 Catalogue Numbers	回転速度 (min ⁻¹) revolution/min (Rotating speed of worm)						
	10	20	50	100	150	200	300
G3C 20 - R2	53.99	49.58	43.51	37.73	34.00	31.45	28.02
G3C 20 - R1	54.39	50.07	44.39	39.00	35.77	33.61	30.18
G3C 25 - R1	82.02	75.75	67.22	59.58	54.58	51.25	46.55
G3C 30 - R2	114.66	105.35	93.29	81.34	74.48	69.28	61.93
G3C 30 - R1	113.87	106.23	94.37	83.69	77.12	72.42	66.05
G3C 40 - R1	226.67	214.91	191.10	169.54	157.48	148.07	135.14

ウォーム回転数に対するウォームホイール許容トルクです。

The above references are JGMA standard.

- 目次 CONTENTS
- インフォメーション INFORMATION
- ギヤボックス GEAR BOXES
- ノーバッキングギヤ ANTI BACKLASH SPUR GEARS
- 歯研平歯車 GROUND SPUR GEARS
- 平歯車 SPUR GEARS
- 内歯車 INTERNAL GEARS
- 歯研ラック GROUND RACKS
- ラック RACKS
- へリカル・スクリューギヤ HELICAL GEARS AND SCREW GEARS
- ウォームとウォームホイール WORMS AND WORM WHEELS
- かさ歯車 BEVEL GEARS
- スプロケット SPROCKETS
- 技術資料 REFERENCE DATA

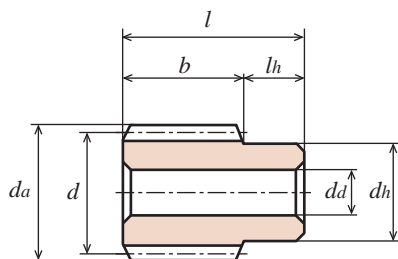

B形
TYPE B

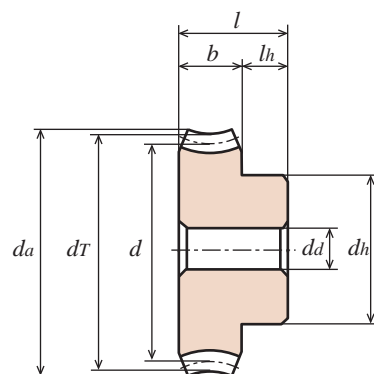

1B形
TYPE 1B

S45C 機械構造用炭素鋼 (JIS G 4051)

Material : Carbon Steel (ISO C45)

単位 : mm
Dimensions : mm

商品記号 Catalogue Number	ねじれ方向 Direction of Thread	条数 Number of Thread z	基準円直径 Reference Diameter d	歯先円直径 Tip Diameter da	形 Type	歯幅 Face Width b	穴径 Bore Diameter da(H8)	ハブ外径 Hub Diameter dh	ハブ長さ Hub Projection lh	全長 Overall Length l	進み角 Lead Angle γ	重量 Weight W(kg)
W4S R1 - B	R	1	φ62	φ70	B	70	φ22	φ50	25	95	3°42'	1.69
W4S R2 - B	R	2	φ62	φ70	B	70	φ22	φ50	25	95	7°25'	1.69

CAC702 アルミニウム青銅鋳物

Material : Aluminum Bronze Casting (JIS CAC702) Dimension X: Coefficient of Rack shift.

単位 : mm
Dimensions : mm

商品記号 Catalogue Number	歯数比 Gear Ratio u	歯数 Number of Teeth z	噛合ピッチ円直径 Pitch Diameter d	転位係数 係数 x	のどの直径 Throat Diameter dT	歯先円直径 Tip Diameter da	形 Type	歯幅 Face Width b	穴径 Bore Diameter da(H8)	ハブ外径 Hub Diameter dh	ハブ長さ Hub Projection lh	全長 Overall Length l	噛合中心距離 Center Distance A	ウォームのねじれ方向及び条数 Hand and Thread for Worm	重量 Weight W(kg)
G4A 20 - R2	10	20	φ80	-0.084	φ88	φ93	1B	36	φ22	φ64	25	61	71	R2	1.81
G4A 20 - R1	20	20	φ80	-0.020	φ88	φ93	1B	36	φ22	φ64	25	61	71	R1	1.81

ウォームホイールの許容トルク (N・m) 歯面強さ

Allowable Transfer Capability Torque of Worm Wheel apply to the rotating speed of Worm only (N・m) as surface durability.

商品記号 Catalogue Numbers	回転速度 (min ⁻¹) revolution/min (Rotating speed of worm)						
	100	250	500	1,000	1,200	1,500	1,800
G4A 20 - R2	72.226	56.350	45.472	35.966	33.124	29.988	27.244
G4A 20 - R1	74.774	60.466	49.392	39.592	36.750	33.712	31.066

ウォーム回転数に対してのウォームホイール許容トルクです。

The above references are JGMA standard.

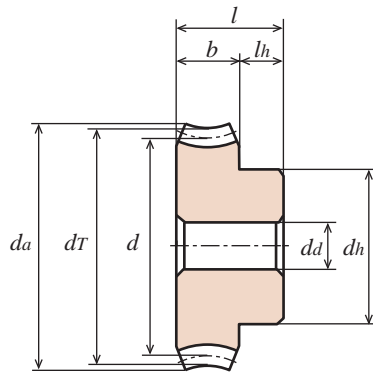

1B形
TYPE 1B

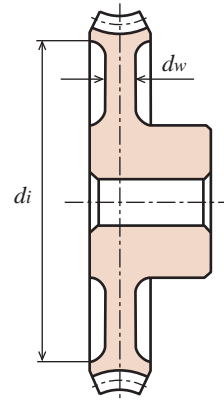

2B形
TYPE 2B

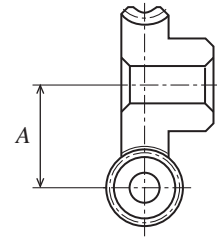

御注文には必ず“フルネームで商品記号”を明記してください。
Please refer to the catalogue reference while ordering.

FC200 ねずみ鋳鉄 (JIS G 5501)

Material : Grey Iron casting (JIS FC200) Dimension X: Coefficient of Rack shift.

単位 : mm
Dimensions : mm

商品記号 Catalogue Number	歯数比 Gear Ratio <i>u</i>	歯数 Number of Teeth <i>z</i>	歯ピッチ 円直径 Pitch Diameter <i>d</i>	転位 係数 Shift Coefficient <i>x</i>	のどの 直径 Throat Diameter <i>dT</i>	歯先円 直径 Tip Diameter <i>da</i>	形 Type	歯幅 Face Width <i>b</i>	穴径 Bore Diameter <i>da(H8)</i>	ハブ 外径 Hub Diameter <i>dh</i>	ハブ 長さ Hub Projection <i>lh</i>	全長 Overall Length <i>l</i>	リム 内径 Dimension of Rim <i>di</i>	ウェブ 厚さ Thickness of Web <i>dw</i>	歯合中心 距離 Center Distance <i>A</i>	ウォームのねじれ 方向及び条数 Hand and Thread for Worm	重量 Weight <i>W(kg)</i>
G4C 20 - R2	10	20	φ 80	-0.084	φ 88	φ 93	1B	36	φ22	φ 64	25	61	-	-	71	R2	1.68
G4C 20 - R1	20	20	φ 80	-0.020	φ 88	φ 93	1B	36	φ22	φ 64	25	61	-	-	71	R1	1.68
G4C 30 - R1	30	30	φ120	-0.031	φ128	φ135	1B	36	φ22	φ 70	25	61	-	-	91	R1	3.20
G4C 40 - R1	40	40	φ160	-0.041	φ168	φ175	2B	40	φ22	φ 80	25	65	φ140	10	111	R1	4.80

ウォームホイールの許容トルク (N・m) 歯面強さ

Allowable Transfer Capability Torque of Worm Wheel apply to the rotating speed of Worm only (N・m) as surface durability.

商品記号 Catalogue Numbers	回転速度 (min ⁻¹) revolution/min (Rotating speed of worm)						
	10	20	50	100	150	200	300
G4C 20 - R2	118.58	108.78	94.08	81.24	73.20	67.52	59.97
G4C 20 - R1	119.46	109.76	95.94	84.08	76.93	72.03	64.58
G4C 30 - R1	301.84	281.35	246.07	217.56	200.11	187.57	170.61
G4C 40 - R1	506.56	479.80	420.12	371.51	344.37	323.30	294.39

ウォーム回転数に対するウォームホイール許容トルクです。

The above references are JGMA standard.

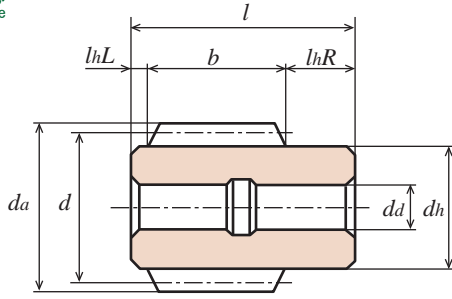

B形
TYPE B

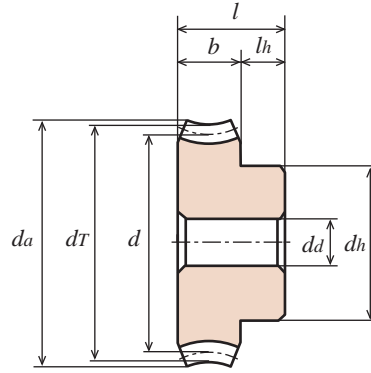

1B形
TYPE 1B

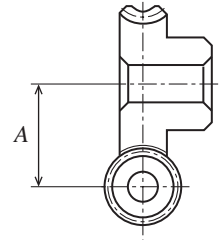

S45C 機械構造用炭素鋼 (JIS G 4051)

Material : Carbon Steel (ISO C45)

単位 : mm
Dimensions : mm

商品記号 Catalogue Number	ねじれ方向 Direction of Thread	条数 Number of Thread <i>z</i>	基準円直径 Reference Diameter <i>d</i>	歯先円直径 Tip Diameter <i>da</i>	形 Type	歯幅 Face Width <i>b</i>	穴径 Bore Diameter <i>da(H8)</i>	ハブ外径 Hub Diameter <i>dh</i>	ハブ長さ Hub Projection		全長 Overall Length <i>l</i>	進み角 Lead Angle γ	重量 Weight <i>W(kg)</i>
									<i>lhL</i>	<i>lhR</i>			
W5S R1 - B	R	1	φ72	φ82	B	90	φ25	φ58	5	30	125	3°58'	3.00
W5S R2 - B	R	2	φ72	φ82	B	90	φ25	φ58	5	30	125	7°59'	3.00

FC200 ねずみ鋳鉄 (JIS G 5501)

Material : Grey Iron casting (JIS FC200) Dimension X: Coefficient of Rack shift.

単位 : mm
Dimensions : mm

商品記号 Catalogue Number	歯数比 Gear Ratio <i>u</i>	歯数 Number of Teeth <i>z</i>	噛み合ピッチ円直径 Pitch Diameter <i>d</i>	転位係数 係数 <i>x</i>	のどの直径 Throat Diameter <i>dT</i>	歯先円直径 Tip Diameter <i>da</i>	形 Type	歯幅 Face Width <i>b</i>	穴径 Bore Diameter <i>da(H8)</i>	ハブ外径 Hub Diameter <i>dh</i>	ハブ長さ Hub Projection <i>lh</i>	全長 Overall Length <i>l</i>	リム内径 Dimension of Rim <i>di</i>	ウェブ厚さ Thickness of Web <i>dw</i>	噛み合中心距離 Center Distance <i>A</i>	ウォームのねじれ方向及び条数 Hand and Thread for Worm	重量 Weight <i>W(kg)</i>
G5C 20 - R2	10	20	φ100	-0.097	φ110	φ118	1B	46	φ25	φ80	26	72	-	-	86	R2	3.20
G5C 20 - R1	20	20	φ100	-0.024	φ110	φ118	1B	46	φ25	φ80	26	72	-	-	86	R1	3.20

ウォームホイールの許容トルク (N・m) 歯面強さ

Allowable Transfer Capability Torque of Worm Wheel apply to the rotating speed of Worm only (N・m) as surface durability.

商品記号 Catalogue Numbers	回転速度 (min ⁻¹) revolution/min (Rotating speed of worm)					
	10	20	50	100	150	200
G5C 20 - R2	247.84	227.26	195.31	168.26	151.41	139.74
G5C 20 - R1	249.90	229.51	199.13	174.24	159.25	149.05

ウォーム回転数に対するウォームホイール許容トルクです。

The above references are JGMA standard.



マイタギヤ / ベベルギヤ

Miter Gears and Bevel Gears

商品記号の読み方 Reference of Catalogue Number

マイタギヤ / ベベルギヤ

M 1 D 25 * 23 06
M 1 S 20 = 14 08
M 1.5 S 20 # 28 10 H
M 1 S 20 R + 21 08
B 2 S 18 L - 10

歯車の種類 Kind of Gear	モジュール Module	材質 Materials	歯数 Number of Teeth	歯すじ形状 Shape of Teeth	穴仕上 Bores Processed	位置決距離 Locating Distance	穴径 Bore Diameter	歯部処理 Heat Treatment
Miter Gear (マイタギヤ) Bevel Gear (ベベルギヤ)	m : 0.5 0.8 1.0 1.25 1.5 2.0 2.5 3.0 4.0 5.0 2.25 2.75 3.5 3.75 4.5 6.0 7.0 Expressed the unit of module's size. Module 0.5 and 0.8 as multiple of 100. Example. module 0.5 → 50 module 0.8 → 80	DM : 射出成形品 Injection molded gear with Poly Acetal D : ポリアセタール Machined gear with Poly Acetal SU : SUS304 Stainless Steel B : 黄銅 Brass S : S45C Carbon Steel DB : ポリアセタール (黄銅ブッシュ入) Poly Acetal with Brass Bush	z : 19 20 23 25 30 u Ratio 2 (z : 20 40) (z : 18 36) u Ratio 3 (z : 15 45)	無 : ストレート Blank : Straight. R : スパイラル 右ねじれ Right hand spiral. L : スパイラル 左ねじれ Left hand spiral.	【-】: 旋削加工 Gear without key way / without threaded hole. 【+】: 旋削加工 ネジ穴付 Gear with threaded hole / with set screw. with out set screw. (Please refer the detail) 【*】: 旋削加工 ネジ穴付 Gear with two threaded holes / with two set screws. 【=】: 旋削加工 キーみぞ付 Gear with key way / with key. 【#】: 旋削加工 キーみぞ、ネジ穴 付 Gear with key way and threaded hole / with key and screw.	単位 : ミリメートル Dimensions : Millimeter	単位 : ミリメートル Dimensions : Millimeter	歯部高周波焼入済 Gear tooth surface completed with induction harden

ベベルギヤの使用上の注意

Usage precaution of bevel Gears.

- 理想的な噛み合いを得る為に、歯車軸の軸角は、出来るだけ正確に、バックラッシも適正に与えて組み立てて下さい。
- ベベルギヤの場合、特に注意することは、その取り付け方法です。多くの場合に、ベベルギヤの軸受は片持ちとなりますから、荷重を受けると軸がたわみ易い欠点があります。そのために歯当りが片当たりとなって悪くなります。歯車軸及び軸受は十分に頑丈にして、歯車に接近させて軸受を設けるようにして下さい。組み立ての際にベベルギヤを軸方向に調整出来るようにして、歯当りを良くする為ハブの端面にシムを入れると歯当りの調整が容易に出来ます。
- 機械切りをした、ストレートベベルギヤのピッチ円周速度は 328m / min 程度以内とし、それ以上の周速度で使用する場合は、スパイラルベベルギヤをご使用下さるようお勧め致します。グリーンソン社では、ピッチ円周速度が 5.5m / s 以上かまたは毎分回転数が 1,000 以上の時はスパイラルベベルギヤをそして周速度が 40m / s 以上では研削をしたスパイラルベベルギヤを推奨しております。
- スパイラルベベルギヤは、ストレートベベルギヤよりも、同時噛み合い歯数が多く常に何枚かの歯がピッチ円すい上において接触をしていますので、円滑な回転を伝達することが出来ます。また、歯と歯の接触線はピッチ円すい母線に対して同時噛み合い歯数が多いことと、1枚の歯先に荷重が集中しないで、非常に丈夫な為、より小さく設計することが出来、高速度回転に使用出来る長所があります。短所としては、歯すじが曲がっているために、スラストが発生します。従って、スラストを十分ささえる様に軸受を設けて下さい。

スパイラルベベルギヤに働くスラスト

Generate a thrust load on Spiral gear.

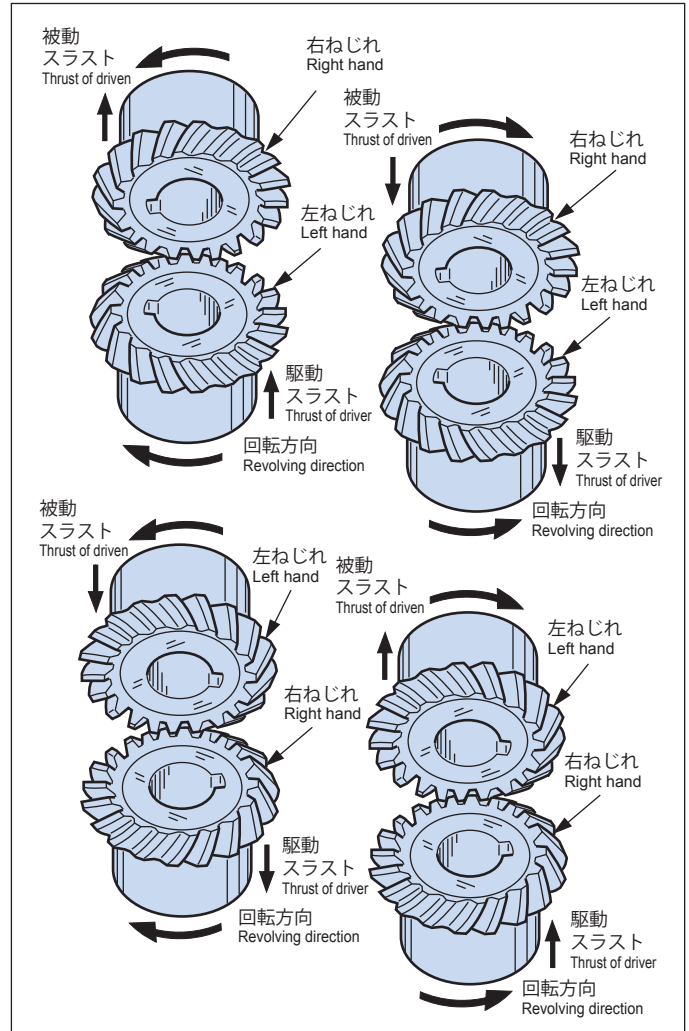

- To obtain ideal engagement of the bevel gears, the correct shaft angle and proper backlash should be obtained to assemble in an assembly.
- Important note that when designing of Bevel Gears, the gear shaft and gearbox must be strong enough to support the Bevel Gear in order to prevent any deflection. Bearing should be designed as close as possible to the Bevel Gear in order to prevent the overhang load.
- We recommend that Straight Bevel Gears are suitable for peripheral (pitch circle) of velocities less than 328m/min and Spiral Bevel Gears are suitable for peripheral (pitch circle) of velocities more than 328m/min. The above mention statement does not apply to Injection Molded type of Bevel Gears. Gleason Company in USA recommend that Machined Spiral Bevel Gears are suitable for peripheral (pitch circle) of velocities more than 5.5m/s or above 1,000 revolution per minute, and Ground Spiral Bevel Gears are suitable for peripheral (pitch circle) of velocities more than 40m/s.
- Spiral Bevel Gears are able to run smoothly in high speed environment and providing a quiet operation, due to fewer number of teeth contacting the matched gear and wide working number of teeth on the pitch cone comparing to Straight Bevel Gear. Spiral Bevel Gear has overlapping engagement in pitch cone generatrix and the load does not concentrate on one (1) tooth. The only disadvantage of a Spiral Bevel Gear is the axial thrust load that was generated due to the Helix design of the teeth trace. Therefore proper design of the bearing location and firm support are needed to be as close to the Spiral Bevel Gear as possible in order to minimize this axial thrust load.

相手歯車を弊社以外の商品と組み合わせると 不具合が発生する恐れがあります。KG STOCK GEARS 以外の仕様で設計される時は 弊社迄 ご相談ください。

To prevent the trouble of gear's engagement, please do not match the gears with other gear makers. Purchase of KG-STOCK GEARS in a set will result in better and smoother engagement.

Please do not hesitate to contact us for advice even though if your design and dimensions does not belong to KG-STOCK GEARS.

Memo

目次
CONTENTS

インフォメーション
INFORMATION

ギヤボックス
GEAR BOXES

ノーバッキングギヤ
ANTI BACKLASH SPUR GEARS

歯研平歯
GROUND SPUR GEARS

平歯
SPUR GEARS

内歯
INTERNAL GEARS

歯ラック
GROUND RACKS

ラック
RACKS

へりかきスクリューギヤ
HELICAL GEARS AND SCREW GEARS

ワーム・ワームホイール
WORMS AND WORM WHEELS

かみ歯
BEVEL GEARS

スプロケット
SPROCKETS

技術資料
REFERENCE DATA

ファインカットマイタギヤ

FINE CUT SPIRAL MITER GEARS

モジュール **1.5**
MODULE

圧力角 20° 歯数比 1:1 ねじれ角 35°
1:1 Ratio 20° PRESSURE ANGLE 35° SPIRAL ANGLE

歯部高周波焼入 HRC47 ~ 51
JIS B1704 2級
System of accuracy : JIS B1704 Class 2



仕様変更 締結加工不要。
Additional machining on tightening is not necessary.

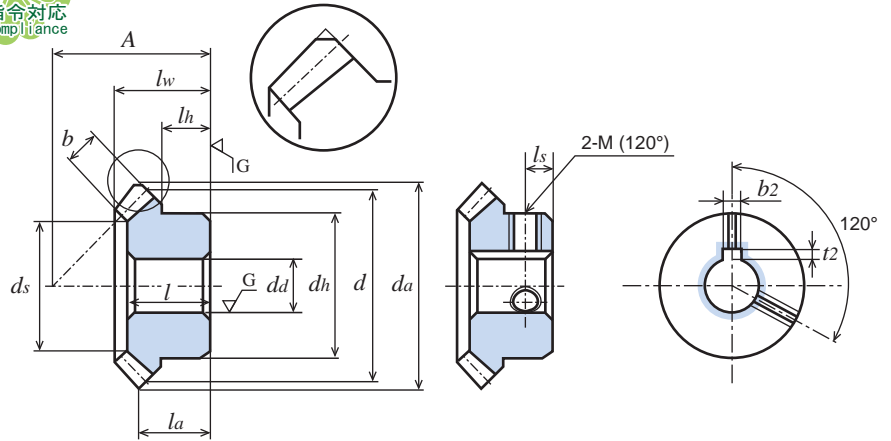

SCM435、440 クロムモリブデン鋼 (JIS G 4053)
Material : Chromium Molybdenum Steel (ISO 34CrMo4,42CrMo4)

単位 : mm
Dimensions : mm

商品記号 Catalogue Number	歯数 Number of Teeth z	基準円直径 Reference Diameter d	歯先円直径 Tip Diameter da	組立距離 Locating Distance A	穴径 Bore Diameter da(H7)	ハブ外径 Hub Diameter dh	ハブ長さ Hub Projection lh	穴長さ Bore Length l	全長 Overall Length lw	Tip Distance la	歯幅 Face Width b	キミぞ Key Way bs × ts	ねじ Set Screw		歯先角 Face Angle δa	歯先角 Face Angle ds	重量 Weight W(g)
													M	ls			
MF1.5S 19R - 2810H	19	φ28.5	^(φ30.34) φ28.5	28	φ10	φ25	12	16	18.19	14.67	5.5	-	-	-	50°23'	φ17.4	54.7
MF1.5S 19L - 2810H	19	φ28.5	^(φ30.34) φ28.5	28	φ10	φ25	12	16	18.19	14.67	5.5	-	-	-	50°23'	φ17.4	54.7
MF1.5S 19R # 2812H	19	φ28.5	^(φ30.34) φ28.5	28	φ12	φ25	12	16	18.19	14.67	5.5	4 × 1.8	2-M4	6	50°23'	φ17.4	49.1
MF1.5S 19L # 2812H	19	φ28.5	^(φ30.34) φ28.5	28	φ12	φ25	12	16	18.19	14.67	5.5	4 × 1.8	2-M4	6	50°23'	φ17.4	49.1
MF1.5S 23R - 3212H	23	φ34.5	^(φ36.33) φ34.5	32	φ12	φ30	12.5	18	19.91	15.67	6.5	-	-	-	49°22'	φ22.6	88.1
MF1.5S 23L - 3212H	23	φ34.5	^(φ36.33) φ34.5	32	φ12	φ30	12.5	18	19.91	15.67	6.5	-	-	-	49°22'	φ22.6	88.1
MF1.5S 23R # 3215H	23	φ34.5	^(φ36.33) φ34.5	32	φ15	φ30	12.5	18	19.91	15.67	6.5	5 × 2.3	2-M5	8	49°22'	φ22.6	77.1
MF1.5S 23L # 3215H	23	φ34.5	^(φ36.33) φ34.5	32	φ15	φ30	12.5	18	19.91	15.67	6.5	5 × 2.3	2-M5	8	49°22'	φ22.6	77.1

カタログ記号の末尾に【H】を付した商品は歯部高周波焼入済です。【H】: Gear tooth surface completed with induction hardening, Hardness HRC 47 to 51.

【=】(イコール)にはキー材が付いております。【=】: Gear with key way / with key.

【#】(シャープ)にはキー材とセットスクリューが付いております。【#】: Gear with key way and threaded hole / with key and screw.

歯先円直径 da の () 内は理論値です。最大外径は軸心と平行に面取りしてありますので、理論値より小さくなっています。

The numeric indicated in the bracket () under the column. Outside diameter da has been machined flat. With this process, the outer diameter is smaller than the theory with respect to shaft center to parallel.

許容伝達動力表 曲げ強さ (kW)

Allowable transfer capability table (kW) Bending Strength

商品記号 Catalogue Numbers	回転速度 (min ⁻¹) revolution/min						
	100	250	500	800	1,000	1,500	2,000
MF1.5S 19R	0.054	0.137	0.274	0.432	0.525	0.736	0.922
MF1.5S 23R	0.084	0.212	0.424	0.652	0.789	1.094	1.385

歯面強さ (kW)

Allowable transfer capability table (kW) Surface Durability

商品記号 Catalogue Numbers	回転速度 (min ⁻¹) revolution/min						
	100	250	500	800	1,000	1,500	2,000
MF1.5S 19R	0.025	0.067	0.138	0.223	0.273	0.391	0.495
MF1.5S 23R	0.047	0.123	0.255	0.401	0.489	0.691	0.886

The above references are JGMA standard.

動力の換算式は P26 をご参照ください。Please refer to the conversion formulas of power on page P26.

歯部高周波焼入 HRC47 ~ 51
JIS B1704 2級
System of accuracy: JIS B1704 Class 2



御注文には必ず“フルネームで商品記号”を明記してください。
Please refer to the catalogue reference while ordering.
 d_s の寸法は参考値です。
Dimension of d_s is for reference only.

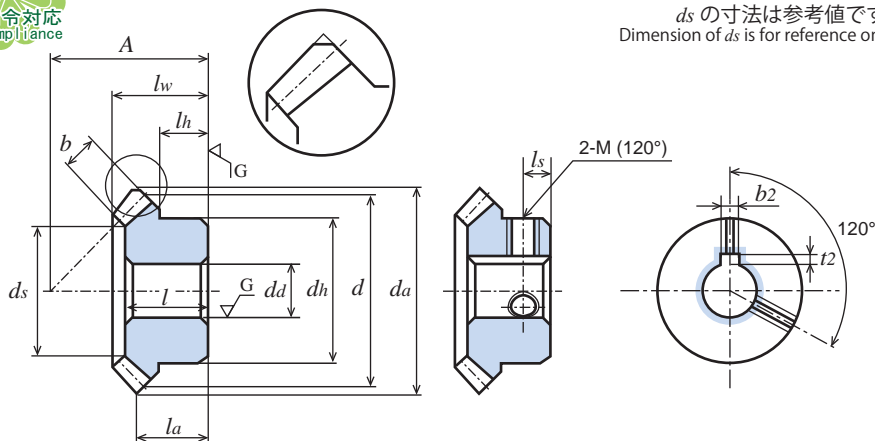

SCM435、440 クロムモリブデン鋼 (JIS G 4053)

Material: Chromium Molybdenum Steel (ISO 34CrMo4, 42CrMo4)

単位: mm
Dimensions: mm

商品記号 Catalogue Number	歯数 Number of Teeth z	基準円直径 Reference Diameter d	歯先円直径 Tip Diameter d_a	組立距離 Locating Distance A	穴径 Bore Diameter $\phi d(H7)$	ハブ外径 Hub Diameter ϕd_h	ハブ長さ Hub Projection l_h	穴長さ Bore Length l	全長 Overall Length l_w	Tip Distance l_a	歯幅 Face Width b	キミぞ Key Way $b_s \times t_s$	ねじ Set Screw		歯先角 Face Angle δ_a	歯先角 Face Angle d_s	重量 Weight $W(g)$
													M	l_s			
MF2S 19R - 3512H	19	$\phi 38$	$\phi 38.0$ <small>($\phi 40.43$)</small>	35	$\phi 12$	$\phi 32$	13	19	22.09	17.21	7.5	-	-	-	49°39'	$\phi 22.8$	113.4
MF2S 19L - 3512H	19	$\phi 38$	$\phi 38.0$ <small>($\phi 40.43$)</small>	35	$\phi 12$	$\phi 32$	13	19	22.09	17.21	7.5	-	-	-	49°39'	$\phi 22.8$	113.4
MF2S 19R # 3515H	19	$\phi 38$	$\phi 38.0$ <small>($\phi 40.43$)</small>	35	$\phi 15$	$\phi 32$	13	19	22.09	17.21	7.5	5 × 2.3	2-M5	8	49°39'	$\phi 22.8$	101.9
MF2S 19L # 3515H	19	$\phi 38$	$\phi 38.0$ <small>($\phi 40.43$)</small>	35	$\phi 15$	$\phi 32$	13	19	22.09	17.21	7.5	5 × 2.3	2-M5	8	49°39'	$\phi 22.8$	101.9
MF2S 23R - 4015H	23	$\phi 46$	$\phi 46.0$ <small>($\phi 48.52$)</small>	40	$\phi 15$	$\phi 40$	14	21	24.43	18.26	9.5	-	-	-	49°39'	$\phi 27.1$	191.9
MF2S 23L - 4015H	23	$\phi 46$	$\phi 46.0$ <small>($\phi 48.52$)</small>	40	$\phi 15$	$\phi 40$	14	21	24.43	18.26	9.5	-	-	-	49°39'	$\phi 27.1$	191.9
MF2S 23R # 4020H	23	$\phi 46$	$\phi 46.0$ <small>($\phi 48.52$)</small>	40	$\phi 20$	$\phi 40$	14	21	24.43	18.26	9.5	6 × 2.8	2-M5	9	49°39'	$\phi 27.1$	166.5
MF2S 23L # 4020H	23	$\phi 46$	$\phi 46.0$ <small>($\phi 48.52$)</small>	40	$\phi 20$	$\phi 40$	14	21	24.43	18.26	9.5	6 × 2.8	2-M5	9	49°39'	$\phi 27.1$	166.5

カタログ記号の末尾に【H】を付した商品は歯部高周波焼入済です。【H】: Gear tooth surface completed with induction hardening, Hardness HRC 47 to 51.

【=】(イコール)にはキー材が付いております。【=】: Gear with key way / with key.

【#】(シャープ)にはキー材とセットスクリューが付いております。【#】: Gear with key way and threaded hole / with key and screw.

歯先円直径 d_a の () 内は理論値です。最大外径は軸心と平行に面取りしてありますので、理論値より小さくなっています。

The numeric indicated in the bracket () under the column. Outside diameter d_a has been machined flat. With this process, the outer diameter is smaller than the theory with respect to shaft center to parallel.

許容伝達動力表 曲げ強さ (kW)

Allowable transfer capability table (kW) Bending Strength

商品記号 Catalogue Numbers	回転速度 (min ⁻¹) revolution/min						
	100	250	500	800	1,000	1,500	2,000
MF2S 19R	0.133	0.334	0.668	1.014	1.223	1.685	2.150
MF2S 23R	0.215	0.539	1.060	1.587	1.901	2.640	3.359

The above references are JGMA standard.

動力の換算式は P26 をご参照ください。Please refer to the conversion formulas of power on page P26.

歯面強さ (kW)

Allowable transfer capability table (kW) Surface Durability

商品記号 Catalogue Numbers	回転速度 (min ⁻¹) revolution/min						
	100	250	500	800	1,000	1,500	2,000
MF2S 19R	0.064	0.167	0.344	0.533	0.649	0.911	1.178
MF2S 23R	0.123	0.320	0.648	0.991	1.199	1.694	2.183

ファインカットマイタギヤ

FINE CUT SPIRAL MITER GEARS

モジュール **2.5**
MODULE

圧力角 20° 歯数比 1:1 ねじれ角 35°
1:1 Ratio 20° PRESSURE ANGLE 35° SPIRAL ANGLE

歯部高周波焼入 HRC47 ~ 51
JIS B1704 2級
System of accuracy : JIS B1704 Class 2



仕様変更 締結加工不要。
Additional machining on tightening is not necessary.

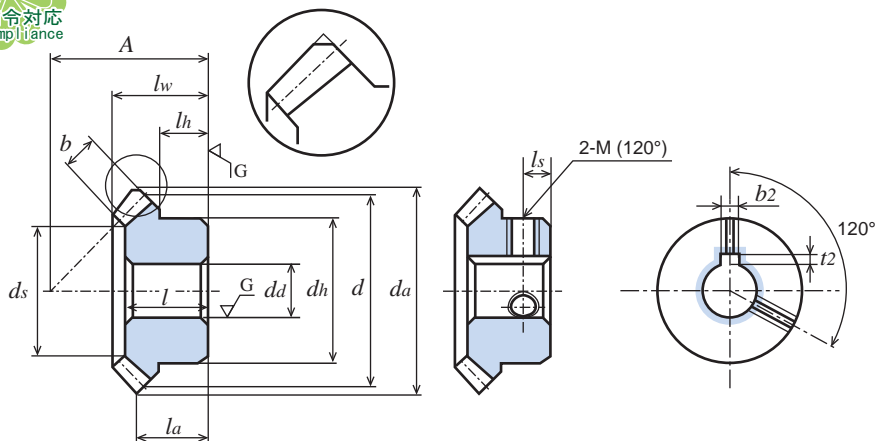

SCM435、440 クロムモリブデン鋼 (JIS G 4053)
Material : Chromium Molybdenum Steel (ISO 34CrMo4,42CrMo4)

単位 : mm
Dimensions : mm

商品記号 Catalogue Number	歯数 Number of Teeth z	基準円直径 Reference Diameter d	歯先円直径 Tip Diameter da	組立距離 Locating Distance A	穴径 Bore Diameter da(H7)	ハブ外径 Hub Diameter dh	ハブ長さ Hub Projection lh	穴長さ Bore Length l	全長 Overall Length lw	全長 Overall Length la	歯幅 Face Width b	キーみぞ Key Way b _s × t _s	ねじ Set Screw		歯先角 Face Angle δ _a	歯先角 Face Angle δ _s	重量 Weight W(g)
													M	l _s			
MF2.5S 19R - 4215H	19	φ47.5	(φ50.55) φ47.5	42	φ15	φ40	14.5	23	25.93	19.78	9.5	-	-	-	49°48'	φ30.1	210.8
MF2.5S 19L - 4215H	19	φ47.5	(φ50.55) φ47.5	42	φ15	φ40	14.5	23	25.93	19.78	9.5	-	-	-	49°48'	φ30.1	210.8
MF2.5S 19R # 4220H	19	φ47.5	(φ50.55) φ47.5	42	φ20	φ40	14.5	23	25.93	19.78	9.5	6 × 2.8	2-M6	10	49°48'	φ30.1	182.5
MF2.5S 19L # 4220H	19	φ47.5	(φ50.55) φ47.5	42	φ20	φ40	14.5	23	25.93	19.78	9.5	6 × 2.8	2-M6	10	49°48'	φ30.1	182.5
MF2.5S 23R - 4815H	23	φ57.5	(φ60.63) φ57.5	48	φ15	φ50	15.5	24	28.30	20.81	11.5	-	-	-	49°30'	φ34.5	363.9
MF2.5S 23L - 4815H	23	φ57.5	(φ60.63) φ57.5	48	φ15	φ50	15.5	24	28.30	20.81	11.5	-	-	-	49°30'	φ34.5	363.9
MF2.5S 23R # 4825H	23	φ57.5	(φ60.63) φ57.5	48	φ25	φ50	15.5	24	28.30	20.81	11.5	8 × 3.3	2-M6	10	49°30'	φ34.5	300.5
MF2.5S 23L # 4825H	23	φ57.5	(φ60.63) φ57.5	48	φ25	φ50	15.5	24	28.30	20.81	11.5	8 × 3.3	2-M6	10	49°30'	φ34.5	300.5

カタログ記号の末尾に【H】を付した商品は歯部高周波焼入済です。【H】: Gear tooth surface completed with induction hardening, Hardness HRC 47 to 51.
【#】(シャープ)にはキー材とセットスクリューが付いております。【#】: Gear with key way and threaded hole / with key and screw.

歯先円直径 da の () 内は理論値です。最大外径は軸心と平行に面取りしてありますので、理論値より小さくなっています。

The numeric indicated in the bracket () under the column. Outside diameter da has been machined flat. With this process, the outer diameter is smaller than the theory with respect to shaft center to parallel.

許容伝達動力表 (kW) 曲げ強さ
Allowable transfer capability table (kW) Bending Strength

商品記号 Catalogue Numbers	回転速度 (min ⁻¹) revolution/min						
	100	250	500	800	1,000	1,500	2,000
MF2.5S 19R	0.264	0.662	1.298	1.939	2.321	3.228	4.103
MF2.5S 23R	0.414	1.036	1.980	2.923	3.474	4.897	6.240

許容伝達動力表 (kW) 歯面強さ
Allowable transfer capability table (kW) Surface Durability

商品記号 Catalogue Numbers	回転速度 (min ⁻¹) revolution/min						
	100	250	500	800	1,000	1,500	2,000
MF2.5S 19R	0.128	0.335	0.678	1.034	1.250	1.769	2.278
MF2.5S 23R	0.240	0.624	1.230	1.853	2.224	3.192	4.119

The above references are JGMA standard.

動力の換算式は P26 をご参照ください。Please refer to the conversion formulas of power on page P26.

歯部高周波焼入 HRC47 ~ 51
JIS B1704 2級
System of accuracy: JIS B1704 Class 2



御注文には必ず“フルネームで商品記号”を明記してください。
Please refer to the catalogue reference while ordering.
 d_s の寸法は参考値です。
Dimension of d_s is for reference only.

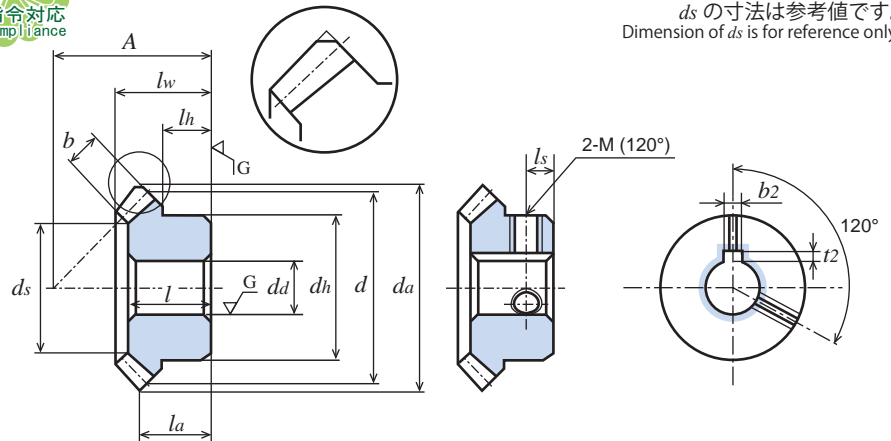

SCM435、440 クロムモリブデン鋼 (JIS G 4053)

Material: Chromium Molybdenum Steel (ISO 34CrMo4, 42CrMo4)

単位: mm
Dimensions: mm

商品記号 Catalogue Number	歯数 Number of Teeth z	基準円直径 Reference Diameter d	歯先円直径 Tip Diameter d_a	組立距離 Locating Distance A	穴径 Bore Diameter $d_d(H7)$	ハブ外径 Hub Diameter d_h	ハブ長さ Hub Projection l_h	穴長さ Bore Length l	全長 Overall Length l_w	Tip Distance l_a	歯幅 Face Width b	キヤミぞ Key Way $b_s \times t_s$	ねじ Set Screw		歯先角 Face Angle δ_a	歯先角 Face Angle d_s	重量 Weight $W(g)$
													M	l_s			
MF3S 19R - 5020H	19	$\phi 57$	$\phi 57.0$ <small>($\phi 60.68$)</small>	50	$\phi 20$	$\phi 48$	17	27	31.09	23.34	12.0	-	-	-	49°56'	$\phi 34.1$	347.8
MF3S 19L - 5020H	19	$\phi 57$	$\phi 57.0$ <small>($\phi 60.68$)</small>	50	$\phi 20$	$\phi 48$	17	27	31.09	23.34	12.0	-	-	-	49°56'	$\phi 34.1$	347.8
MF3S 19R # 5025H	19	$\phi 57$	$\phi 57.0$ <small>($\phi 60.68$)</small>	50	$\phi 25$	$\phi 48$	17	27	31.09	23.34	12.0	8 × 3.3	2-M6	10	49°56'	$\phi 34.1$	306.4
MF3S 19L # 5025H	19	$\phi 57$	$\phi 57.0$ <small>($\phi 60.68$)</small>	50	$\phi 25$	$\phi 48$	17	27	31.09	23.34	12.0	8 × 3.3	2-M6	10	49°56'	$\phi 34.1$	306.4
MF3S 23R - 5520H	23	$\phi 69$	$\phi 68.0$ <small>($\phi 72.73$)</small>	55	$\phi 20$	$\phi 60$	16	27	31.51	22.36	14.0	-	-	-	49°22'	$\phi 42.4$	571.3
MF3S 23L - 5520H	23	$\phi 69$	$\phi 68.0$ <small>($\phi 72.73$)</small>	55	$\phi 20$	$\phi 60$	16	27	31.51	22.36	14.0	-	-	-	49°22'	$\phi 42.4$	571.3
MF3S 23R # 5530H	23	$\phi 69$	$\phi 68.0$ <small>($\phi 72.73$)</small>	55	$\phi 30$	$\phi 60$	16	27	31.51	22.36	14.0	8 × 3.3	2-M8	9	49°22'	$\phi 42.4$	478.7
MF3S 23L # 5530H	23	$\phi 69$	$\phi 68.0$ <small>($\phi 72.73$)</small>	55	$\phi 30$	$\phi 60$	16	27	31.51	22.36	14.0	8 × 3.3	2-M8	9	49°22'	$\phi 42.4$	478.7

カタログ記号の末尾に【H】を付した商品は歯部高周波焼入済です。【H】: Gear tooth surface completed with induction hardening, Hardness HRC 47 to 51.
【#】(シャープ)にはキー材とセットスクリューが付いております。【#】: Gear with key way and threaded hole / with key and screw.

歯先円直径 d_a の () 内は理論値です。最大外径は軸心と平行に面取りしてありますので、理論値より小さくなっています。

The numeric indicated in the bracket () under the column. Outside diameter d_a has been machined flat. With this process, the outer diameter is smaller than the theory with respect to shaft center to parallel.

許容伝達動力表 (kW) 曲げ強さ

Allowable transfer capability table (kW) Bending Strength

商品記号 Catalogue Numbers	回転速度 (min ⁻¹) revolution/min						
	100	250	500	800	1,000	1,500	2,000
MF3S 19R	0.472	1.188	2.274	3.360	3.995	5.626	7.166
MF3S 23R	0.726	1.815	3.374	4.916	5.923	8.319	10.061

The above references are JGMA standard.

動力の換算式は P26 をご参照ください。Please refer to the conversion formulas of power on page P26.

許容伝達動力表 (kW) 歯面強さ

Allowable transfer capability table (kW) Surface Durability

商品記号 Catalogue Numbers	回転速度 (min ⁻¹) revolution/min						
	100	250	500	800	1,000	1,500	2,000
MF3S 19R	0.233	0.608	1.201	1.812	2.176	3.119	4.023
MF3S 23R	0.425	1.108	2.123	3.157	3.841	5.493	7.098

特徴

Feature of B-LOCKS.

1) B-LOCK のすぐれた特徴

- ① B-LOCK は歯車のボス部の締結機構により歯車と軸を固定するため、セットスクリューによる固定等のような軸へのへこみ傷が付きにくくなっております。
- ② B-LOCK は歯車のかみ合い調整を必要とする場合に適しております。
- ③ 歯車と軸を固定するための軸へのキー溝や D カット加工などを施す必要がありません。

ベベルギヤのバックラッシ量を調整するためには一般的には次の工程で行います。

Generally, the process of adjustment for gear backlash is as follows;-

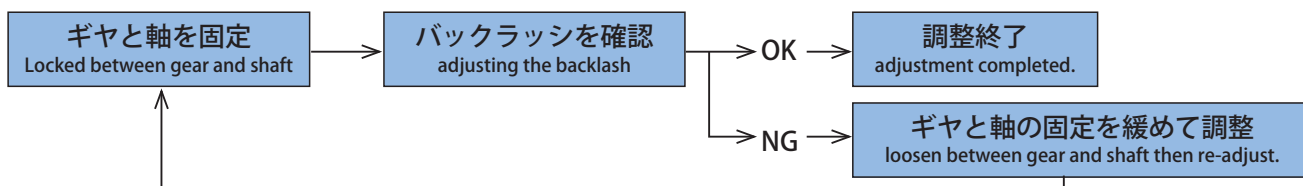

2) 既存のストレートマイタ歯車と互換性をもたせてありますので、相手歯車に既存のストレートマイタ歯車でも使用できます。

- 1) B-LOCK is a straight miter gear design with a locking mechanism that enable the gear and gear shaft to be tightened. The locking mechanism of B-LOCK tightens the gear shaft from the hub thus causing lesser damage to the gear shaft surface.
- 2) B-LOCK of Straight Miter gear has suitable mechanism for adjustment of the gear engagement.
- 3) Key way and D-cut are not necessary for tightening of the gear to the shaft.
- 4) B-LOCK of Straight Miter gear is easy for maintenance and adjustment.
- 5) KG-Straight Miter gears can match with KG- B-LOCKS because of the gear's tooth specification.

使用上の注意

Usage of precaution.

- 1) 商品の選定は使用上の最大トルクが許容伝達動力表のトルク値以下となる商品を選定して下さい。その際、モーターの起動トルクによる事故防止のため起動トルクを考慮して下さい。
- 2) 組立後すぐに実負荷をかけた運転は避け軽負荷による運転確認後実負荷運転を行って下さい。
- 3) 軽負荷によるならし運転を行った後に締め付けネジを再度トルクレンチを使用し指定の締め付けトルク値に締め直す確認を行って下さい。
- 4) 追加工は締結力に支障の無い範囲内として下さい。穴長さ、穴径、ボス径の追加工及び熱処理は行わないで下さい。
- 5) 使用上、特に起動回数の多い場合は本シリーズ以外のキー溝付の商品のご使用を推奨します。

- 1) For best selection, do not exceed the number (W) indicated in the Allowable Transfer Capability Table for the maximum torque of usage. Starting torque is an important factor to consider for prevention of any accident.
- 2) After assembly, warm up and test run with light load is highly recommended. Please do not apply actual load to the B-LOCK before warm up test run.
- 3) Re-Locking after the warm up test run is necessarily important by using a torque wrench to tighten at the recommended torque.
- 4) Additional machining to the B-LOCK and heat treatment are not allowed.
- 5) If the usage of frequently revolution, gear with keyway is recommended.

取り付け軸の精度 Precision of the gear shaft.

- 1) 軸径の公差は h7 以上の精度の軸を使用して下さい。
- 2) 軸の面粗さは 1.6a (6.3S) 以上の精度で仕上げた軸を使用して下さい。
- 1) Recommended tolerance of shaft is h7 or above.
- 2) Recommended surface roughness of shaft is 1.6a (6.3s) or above.

歯車の取り付け Installation of KG B-LOCK.

- 1) 締め付けネジを締める際は、トルクレンチを使用し指定の締め付けトルクにて 2 回～3 回締め付け直しを行って下さい。
(締め付けトルクの確認と締め付けネジの緩み防止のため)
- 2) 締め付けネジの緩み防止のためにネジ部への緩み防止剤の使用を推奨します。
- 3) 締め付けに使用する締め付けネジは、JIS の強度区分 10.9 級以上のボルトを使用して下さい。
- 1) In order to confirm the locked torque and prevent lose nut condition, torque wrench is recommended to tighten the screw few times for re-adjustment.
- 2) Anti-looseness products are recommended to apply.
- 3) Recommended screw for the tightening is JIS classification of strength class 10.9 or above.

その他 Other

万一、歯車が空転した場合は、歯車同士のかみ合いが外れる際に発生する歯の断片が他の機械要素部品へ影響を及ぼすことがありますので必ず他の機械要素部品の点検及び清掃を行って下さい。
本製品は、機能上支障の無い範囲で予告なく寸法変更させていただく場合がございます。あらかじめご了承ください。

Under unforeseen circumstances, when mis-engagement between two gears happened, this causes the B-LOCK to slip during operation. This fault needs to be rectified immediately and all foreign objects (e.g. chips or burrs) are to be removed or cleaned before installation again.

All dimensions and descriptions are subject to changes without prior notice.

本製品は、機能上支障の無い範囲で予告なく寸法変更させていただく場合がございます。あらかじめご了承ください。
All dimensions and descriptions are subject to changes without prior notice.

B-LOCK ビーロック

B-LOCK SERIES

モジュール **0.8/1/1.5/2**
MODULE

圧力角 20° 歯数比 1:1
1:1 Ratio 20° PRESSURE ANGLE

JIS B1704 4級
System of accuracy : JIS B1704 Class 4



d_s の寸法は参考値です。
Dimension of d_s is for reference only.

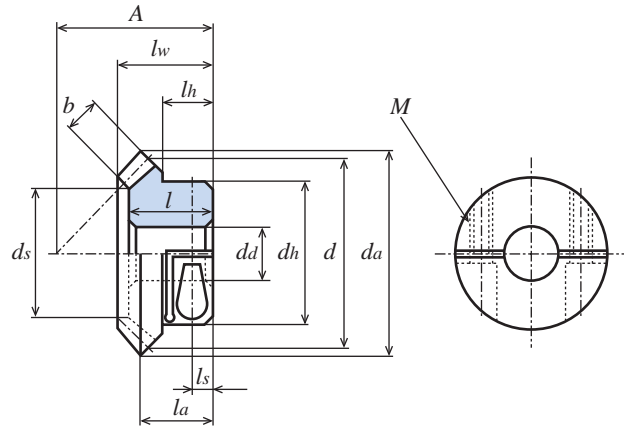

SUS304 ステンレス鋼棒 (JIS G 4303)

Material : Stainless Steel SUS304 (JIS G 4303)

単位 : mm
Dimensions : mm

商品記号 Catalogue Number	歯数比 Gear Ratio u	歯数 Number of Teeth z	基準円直径 Reference Diameter d	歯先円直径 Tip Diameter d_a	組立距離 Locating Distance A	穴径 Bore Diameter $d_a(H8)$	ハブ外径 Hub Diameter d_h	ハブ長さ Hub Projection l_h	穴長さ Bore Length l	全長 Overall Length l_w	全長 Overall Length l_a	歯幅 Face Width b	ねじ Set Screw		歯先角 Face Angle δ_a	d_s	重量 Weight $W(g)$
													M	l_s			
ML80SU 20 - 1605	1	20	$\phi 16$	$\phi 17.13$	16	$\phi 5$	$\phi 14.5$	7.25	10	10.95	8.57	3.7	M2.5	3	49° 3'	$\phi 9.5$	10.2
ML1SU 20 - 2106	1	20	$\phi 20$	$\phi 21.41$	21	$\phi 6$	$\phi 16$	9	13	14.48	11.71	4.3	M3	4	49° 3'	$\phi 11.8$	18.6
ML1SU 30 - 2808	1	30	$\phi 30$	$\phi 31.41$	28	$\phi 8$	$\phi 24$	11	16.5	17.84	13.71	6.2	M4	5	47° 42'	$\phi 19.4$	54.3
ML1.5SU 20 - 3010	1	20	$\phi 30$	$\phi 32.12$	30	$\phi 10$	$\phi 24$	12	18.5	20.38	16.06	6.8	M4	5	49° 3'	$\phi 17.7$	57.3
ML1.5SU 25 - 3412	1	25	$\phi 37.5$	$\phi 39.62$	34	$\phi 12$	$\phi 30$	12.5	19	21.11	16.31	7.5	M5	5.5	48° 51'	$\phi 23.8$	94.0
ML2SU 20 - 3715	1	20	$\phi 40$	$\phi 41.32$	37	$\phi 15$	$\phi 34$	14	21	23.85	19.07	8.5	M5	6	49° 3'	$\phi 23.9$	121.5

締め付けネジが付いております。
B-LOCK Miter gear with clamp screw.
Mating miter gears should be the same as module size, number of teeth and face width.

許容伝達動力表 (W)

Allowable transfer capability table (W) Bending Strength

商品記号 Catalogue Numbers	回転速度 (min ⁻¹) revolution/min						
	10	50	100	250	500	800	1,000
ML80SU 20 - 1605	0.2	1.3	2.6	6.5	13.1	20.9	26.2
ML1SU 20 - 2106	0.4	2.4	4.8	12.1	24.4	39.1	48.5
ML1SU 30 - 2808	1.2	6.1	12.2	30.5	61.1	94.5	113.5
ML1.5SU 20 - 3010	1.6	8.5	17.0	42.7	85.4	132.0	158.4
ML1.5SU 25 - 3412	2.6	13.2	26.5	66.4	132.9	197.3	234.9
ML2SU 20 - 3715	3.8	19.4	38.8	97.1	193.0	284.7	338.1

ねじの締め付けトルク (N·m) Recommendable power of screw tightening Torque (N·m)
0.68
0.98
2.45
2.45
3.92
3.92

相手歯車 商品記号 (既存商品) Example of some matching KG Miter gears.
M80SU 20 + 1605
M1SU 20 + 2106
M1SU 30 + 2608
M1.5SU 20 - 2810
M1.5SU 25 - 3410
M2SU 20 - 3712

材質 SUS304 の許容伝達動力値は参考値となります。
The above numerical value are reference value.
動力の換算式は P26 をご参照ください。
Please refer to the conversion formulas of power on page P26.

JIS B1704 3級
System of accuracy: JIS B1704 Class 3



御注文には必ず“フルネームで商品記号”を明記してください。
Please refer to the catalogue reference while ordering.

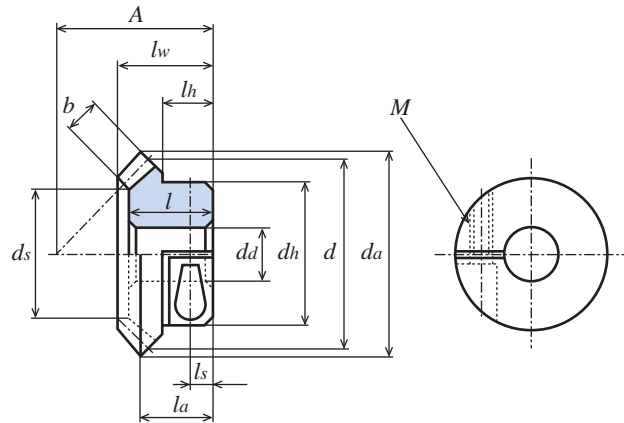

S45C 機械構造用炭素鋼 (JIS G 4051)

Material: Carbon Steel (ISO C45)

単位: mm
Dimensions: mm

商品記号 Catalogue Number	歯数比 Gear Ratio <i>u</i>	歯数 Number of Teeth <i>z</i>	基準円直径 Reference Diameter <i>d</i>	歯先円直径 Tip Diameter <i>da</i>	組立距離 Locating Distance <i>A</i>	穴径 Bore Diameter <i>da(H7)</i>	ハブ外径 Hub Diameter <i>dh</i>	ハブ長さ Hub Projection <i>lh</i>	穴長さ Bore Length <i>l</i>	全長 Overall Length <i>lw</i>	全長 Overall Length <i>la</i>	歯幅 Face Width <i>b</i>	ねじ Set Screw		歯先角 Face Angle <i>δa</i>	歯先角 Face Angle <i>δs</i>	重量 Weight <i>W(g)</i>
													<i>M</i>	<i>ls</i>			
ML1S 20 – 2108	1	20	φ20	φ21.41	21	φ 8	φ18	10	13	14.48	11.71	4.3	M3	4	49° 3'	φ11.8	19.5
ML1.5S 20 – 3010	1	20	φ30	φ32.12	30	φ10	φ24	12	18.5	20.38	16.06	6.8	M4	5	49° 3'	φ17.7	54.6
ML1.5S 25 – 3412	1	25	φ37.5	φ39.62	34	φ12	φ30	12.5	19	21.11	16.31	7.5	M5	5.5	48°51'	φ23.8	93.4
ML2S 20 – 3715	1	20	φ40	φ41.32	37	φ15	φ34	14	21	23.85	18.41	8.5	M5	5.5	49° 3'	φ23.9	119.2
ML2.5S 20 – 4820	1	20	φ50	φ51.66	48	φ20	φ42	19	28	31.86	24.77	11.1	M6	7.5	49° 3'	φ28.5	236.6

締め付けネジが付いております。
B-LOCK Miter gear with clamp screw.
Mating miter gears should be the same as module size, number of teeth and face width.

許容伝達動力表 (W)

Allowable transfer capability table (W) Bending Strength

商品記号 Catalogue Numbers	回転速度 (min ⁻¹) revolution/min						
	10	50	100	250	500	800	1,000
ML1S 20 – 2108	1.0	5.1	10.2	25.6	51.3	82.2	102.0
ML1.5S 20 – 3010	3.5	17.9	35.8	89.7	179.4	277.3	332.8
ML1.5S 25 – 3412	5.5	27.9	55.8	139.5	279.1	414.4	493.4
ML2S 20 – 3715	8.1	40.8	81.6	204.0	405.4	597.9	710.2
ML2.5S 20 – 4820	16.3	81.9	163.9	409.8	786.6	1141.2	1343.2

ねじの締め付けトルク (N・m) Recommendable power of screw tightening Torque (N・m)
1.17
2.54
5.09
5.09
7.84

相手歯車 商品記号 (既存商品) Example of some matching KG Miter gears.
M1S 20 – 2106
M1.5S 20 – 2810
M1.5S 25 – 3410
M2S 20 – 3712
M2.5S 20 – 4814

材質 SUS304 の許容伝達動力値は参考値となります。
The above numerical value are reference value.
動力の換算式は P26 をご参照ください。
Please refer to the conversion formulas of power on page P26.

- 目次 CONTENTS
- インフォメーション INFORMATION
- ギヤボックス GEAR BOXES
- ノーバッキングバックラッシュギヤ ANTI BACKLASH SPUR GEARS
- 歯研平歯車 GROUND SPUR GEARS
- 平歯車 SPUR GEARS
- 内歯車 INTERNAL GEARS
- 歯研ラック GROUND RACKS
- ラック RACKS
- へリカル・スクリューギヤ HELICAL GEARS AND SCREW GEARS
- ワーム・ワームホイール WORMS AND WORM WHEELS
- かなめ歯車 BEVEL GEARS
- スプロケット SPROCKETS
- 技術資料 REFERENCE DATA

MGH スパイラルミタギヤ

SPIRAL MITER GEARS

圧力角 20° 歯数 20 歯数比 1:1 ねじれ角 35°
1:1 Ratio 20° PRESSURE ANGLE 35° SPIRAL ANGLE

JIS B1704 4級
System of accuracy: JIS B1704 Class 4



ds の寸法は参考値です。
Dimension of ds is for reference only.

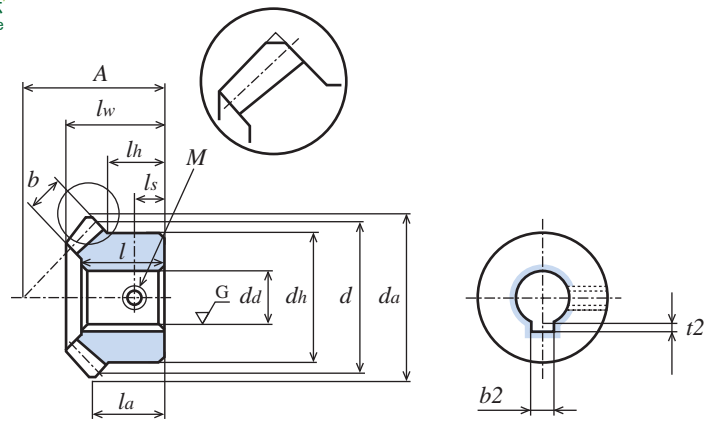

S45C 機械構造用炭素鋼 (JIS G 4051)

Material : Carbon Steel (ISO C45)

単位 : mm
Dimensions : mm

商品記号 Catalogue Number	穴径 Bore Diameter $da(H7)$	モジュール Module m	基準円直径 Reference Diameter d	歯先円直径 Tip Diameter da	組立距離 Locating Distance A	ハブ外径 Hub Diameter dh	ハブ長さ Hub Projection li	穴長さ Bore Length l	全長 Overall Length lw	Tip Distance la	歯幅 Face Width b	キミぞ Key Way $b_2 \times t_2$	ねじ Set Screw		歯先角 Face Angle δ_a	重量 Weight $W(g)$
													M	ls		
MGH R+ 8	$\phi 8$	1	$\phi 20$	$\phi 21.12$	20	$\phi 16$	8	12	13.43	10.56	4.5	-	M4	4	50°31'	16.0
MGH L+ 8	$\phi 8$	1	$\phi 20$	$\phi 21.12$	20	$\phi 16$	8	12	13.43	10.56	4.5	-	M4	4	50°31'	16.0
MGH R+ 10	$\phi 10$	1.25	$\phi 25$	$\phi 26.42$	25	$\phi 20$	10	15.5	17.13	13.21	6	-	M4	5	49°22'	32.0
MGH L+ 10	$\phi 10$	1.25	$\phi 25$	$\phi 26.42$	25	$\phi 20$	10	15.5	17.13	13.21	6	-	M4	5	49°22'	32.0
MGH R= 12	$\phi 12$	1.5	$\phi 30$	$\phi 31.85$	30	$\phi 24$	12	18.5	20.44	15.93	7	4 × 1.8	M5	6	50° 5'	54.9
MGH L= 12	$\phi 12$	1.5	$\phi 30$	$\phi 31.85$	30	$\phi 24$	12	18.5	20.44	15.93	7	4 × 1.8	M5	6	50° 5'	54.9
MGH R= 14	$\phi 14$	2	$\phi 40$	$\phi 40.88$ ($\phi 42.28$)	40	$\phi 32$	16	24	27.16	21.14	9	5 × 2.3	M5	8	48° 3'	137.6
MGH L= 14	$\phi 14$	2	$\phi 40$	$\phi 40.88$ ($\phi 42.28$)	40	$\phi 32$	16	24	27.16	21.14	9	5 × 2.3	M5	8	48° 3'	137.6
MGH R= 16	$\phi 16$	2.25	$\phi 45$	$\phi 46.03$ ($\phi 47.73$)	45	$\phi 36$	18	27.5	30.39	23.86	10	5 × 2.3	M6	9	49°22'	195.6
MGH L= 16	$\phi 16$	2.25	$\phi 45$	$\phi 46.03$ ($\phi 47.73$)	45	$\phi 36$	18	27.5	30.39	23.86	10	5 × 2.3	M6	9	49°22'	195.6

歯先円直径 da の () 内は理論値です。最大外径は軸心と平行に面取りしてありますので、理論値より小さくなっています。

The numeric indicated in the bracket () under the column. Outside diameter da has been machined flat. With this process, the outer diameter is smaller than the theory with respect to shaft center to parallel.

MGH シリーズの特徴

- ・ 歯部高周波焼入済 (HRC47 ~ 53)
 - ・ 穴研削仕上げ済
 - ・ キー材及びセットスクリュー付きです。
- 原則として”追加せず”にご使用頂く完成品です。

The Feature of MGH miter gear series.

- Gear tooth completed with induction harden. (HRC47 to 53)
- Ground bore.
- [+]: Gear with threaded hole / with set screw
- [=]: Gear with key way and key / with threaded hole and set screw

Please install the MGH Miter gear series to your machine without any additional machining as a completed finished gear.

許容伝達動力表 (kW) 曲げ強さ

Allowable transfer capability table (kW) Bending Strength

商品記号 Catalogue Numbers	回転速度 (min ⁻¹) revolution/min						
	300	600	900	1,200	1,500	1,800	2,000
MGH R+ 8	0.030	0.061	0.091	0.118	0.142	0.164	0.179
MGH R+ 10	0.062	0.125	0.184	0.234	0.280	0.322	0.348
MGH R= 12	0.107	0.215	0.297	0.387	0.460	0.525	0.568
MGH R= 14	0.251	0.488	0.680	0.847	0.998	1.150	1.245
MGH R= 16	0.357	0.679	0.940	1.163	1.379	1.583	1.710

許容伝達動力表 (kW) 歯面強さ

Allowable transfer capability table (kW) Surface Durability

商品記号 Catalogue Numbers	回転速度 (min ⁻¹) revolution/min						
	300	600	900	1,200	1,500	1,800	2,000
MGH R+ 8	0.012	0.026	0.040	0.052	0.063	0.074	0.081
MGH R+ 10	0.026	0.054	0.081	0.104	0.126	0.146	0.158
MGH R= 12	0.045	0.093	0.136	0.174	0.208	0.240	0.261
MGH R= 14	0.108	0.216	0.307	0.387	0.460	0.535	0.581
MGH R= 16	0.154	0.303	0.427	0.535	0.641	0.741	0.804

The above references are JGMA standard.

動力の換算式は P26 をご参照ください。Please refer to the conversion formulas of power on page P26.

JIS B1704 4級
System of accuracy : JIS B1704 Class 4



御注文には必ず“フルネームで商品記号”を明記してください。
Please refer to the catalogue reference while ordering.

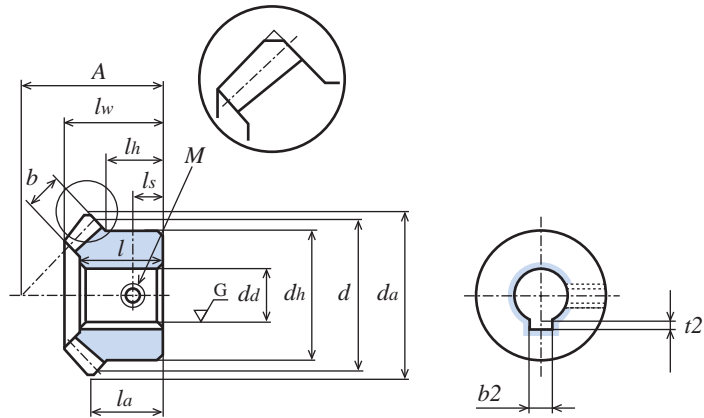

S45C 機械構造用炭素鋼 (JIS G 4051)

Material : Carbon Steel (ISO C45)

単位 : mm
Dimensions : mm

商品記号 Catalogue Number	穴径 Bore Diameter da(H7)	モジュール Module m	基準円直径 Reference Diameter d	歯先円直径 Tip Diameter da	組立距離 Locating Distance A	ハブ外径 Hub Diameter dh	ハブ長さ Hub Projection lh	穴長さ Bore Length l	全長 Overall Length lw	歯幅 Face Width b	キミぞ Key Way b2 × t2	ねじ Set Screw		歯先角 Face Angle δa	重量 Weight W(kg)	
												M	ls			
MGH = 18	φ18	2.5	φ 50	φ 51.66 (φ53.54)	50	φ 40	20	30	33.54	26.77	10.3	6 × 2.8	M6	10	49° 3'	0.26
MGH = 20	φ20	2.75	φ 55	φ 56.82 (φ58.89)	54	φ 44	21	32	35.54	28.45	10.8	6 × 2.8	M6	10.5	49° 3'	0.34
MGH = 22	φ22	3	φ 60	φ 61.99 (φ64.24)	58	φ 48	22	34	38.01	30.12	12	6 × 2.8	M6	11	49° 3'	0.43
MGH = 25A	φ25	3	φ 60	φ 61.99 (φ64.24)	58	φ 48	22	34	38.01	30.12	12	8 × 3.3	M8	11	49° 3'	0.40
MGH = 25B	φ25	3.5	φ 70	φ 72.32 (φ74.95)	66	φ 56	24	39.5	44.05	33.48	16.1	8 × 3.3	M8	12	49° 3'	0.68
MGH = 30	φ30	3.75	φ 75	φ 77.49 (φ80.30)	70	φ 60	25	41.5	46.52	35.15	17.3	8 × 3.3	M8	12.5	49° 3'	0.78
MGH = 32	φ32	4	φ 80	φ 82.65 (φ85.66)	74	φ 64	26	44	49.05	36.83	18.6	10 × 3.3	M8	13	49° 3'	0.94
MGH = 35	φ35	4.5	φ 90	φ 93.00 (φ96.36)	82	φ 72	28	48.5	54.05	40.18	21.1	10 × 3.3	M8	14	49° 3'	1.34
MGH = 40	φ40	5	φ100	φ103.32 (φ107.07)	90	φ 80	30	53	59.04	43.54	23.6	12 × 3.3	M8	15	49° 3'	1.77

歯先円直径 da の () 内は理論値です。最大外径は軸心と平行に面取りしてありますので、理論値より小さくなっています。

The numeric indicated in the bracket () under the column. Outside diameter da has been machined flat. With this process, the outer diameter is smaller than the theory with respect to shaft center to parallel.

許容伝達動力表 (kW) 曲げ強さ

Allowable transfer capability table (kW) Bending Strength

商品記号 Catalogue Numbers	回転速度 (min ⁻¹) revolution/min						
	10	100	200	400	600	800	1,000
MGH = 18	0.014	0.143	0.287	0.575	0.825	0.985	1.180
MGH = 20	0.018	0.186	0.373	0.743	1.016	1.273	1.509
MGH = 22	0.024	0.246	0.492	0.952	1.324	1.655	1.951
MGH = 25A	0.024	0.246	0.492	0.952	1.324	1.655	1.951
MGH = 25B	0.044	0.441	0.883	1.669	2.298	2.837	3.373
MGH = 30	0.054	0.542	1.084	2.168	2.784	3.438	4.087
MGH = 32	0.066	0.661	1.323	2.448	3.345	4.148	4.918
MGH = 35	0.094	0.949	1.899	3.420	4.636	5.781	6.818
MGH = 40	0.130	1.307	2.600	4.602	6.219	7.757	-

許容伝達動力表 (kW) 歯面強さ

Allowable transfer capability table (kW) Surface Durability

商品記号 Catalogue Numbers	回転速度 (min ⁻¹) revolution/min						
	10	100	200	400	600	800	1,000
MGH = 18	0.003	0.036	0.075	0.154	0.221	0.281	0.335
MGH = 20	0.004	0.047	0.097	0.198	0.282	0.358	0.426
MGH = 22	0.005	0.061	0.125	0.251	0.356	0.450	0.533
MGH = 25A	0.005	0.061	0.125	0.251	0.356	0.450	0.533
MGH = 25B	0.009	0.109	0.226	0.441	0.619	0.774	0.929
MGH = 30	0.012	0.137	0.280	0.540	0.760	0.946	1.144
MGH = 32	0.015	0.167	0.345	0.655	0.912	1.144	1.368
MGH = 35	0.022	0.243	0.502	0.932	1.287	1.624	1.935
MGH = 40	0.030	0.338	0.694	1.266	1.737	2.197	-

The above references are JGMA standard.

動力の換算式は P26 をご参照ください。Please refer to the conversion formulas of power on page P26.

目次
CONTENTS
インフォメーション
INFORMATION
ギヤボックス
GEAR BOXES
ノーバッキングギヤ
ANTI BACKLASH SPUR GEARS
歯研削歯車
GROUND SPUR GEARS
平歯車
SPUR GEARS
内歯車
INTERNAL GEARS
歯研削ラック
GROUND RACKS
ラック
RACKS
へリカル・スクリューギヤ
HELICAL GEARS AND SCREW GEARS
ワームとワームホイール
WORMS AND WORM WHEELS
かみ歯車
BEVEL GEARS
スプロケット
SPROCKETS
技術資料
REFERENCE DATA



New **ねじを2箇所 (120°配) にしました。**
New item with two threaded holes (120°)

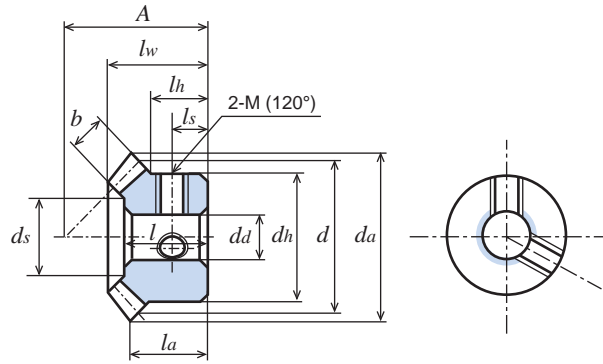

機械加工品
Machined Gears

ポリアセタール 射出成形品 (黒色) 機械加工品 (白色)
Material: Ploy Acetal Injection Molded Gear (black) Machined Gears (white)

単位 : mm
Dimensions : mm

商品記号 Catalogue Number	歯数比 Ratio <i>u</i>	歯数 Number of Teeth <i>z</i>	基準円直径 Reference Diameter <i>d</i>	歯先円直径 Tip Diameter <i>da</i>	組立距離 Locating Distance <i>A</i>	穴径 Bore Diameter <i>dd</i>	ハブ外径 Hub Diameter <i>dh</i>	ハブ長さ Hub Projection <i>lh</i>	穴長さ Bore Length <i>l</i>	全長 Overall Length <i>lw</i>	全長 Tip Distance <i>la</i>	歯幅 Face Width <i>b</i>	ねじ Set Screw		歯先角 Face Angle <i>δa</i>	歯先角 <i>ds</i>	重量 Weight <i>W(g)</i>
													2-M(120°)	<i>ls</i>			

射出成形品 穴径 (*da*) の追加加工はなるべくしないで下さい。気泡 (す) がでることがあります。
Injection Molded gears Additional machining to bore (*da*) is not advisable because 'voids' may be occur.

M50DM 20 - 1103	1	20	φ10	φ10.70	11	φ3	φ8	4	7	8	6.35	2.5	-	-	49° 3'	φ4.9	0.5
M80DM 20 - 1605	1	20	φ16	φ17.10	16	φ5	φ12	5	10	11	8.56	3.7	-	-	49° 3'	φ9.5	1.7
M1DM 20 - 2106	1	20	φ20	φ21.40	21	φ6	φ16	7	13	14.5	11.70	4.3	-	-	49° 3'	φ11.8	3.5
B80DM 20	2	20	φ16	φ17.43	22.5	φ5	φ11	5	10	10.79	6.86	4.5	-	-	29° 8'	φ9.8	1.7
B80DM 40	2	40	φ32	φ32.71	16.46	φ6	φ20	5	9.5	11.01	9.17	4.5	-	-	66° 0'	φ22.9	6.5

機械加工品 Machined Gears

M1D 25 * 2306	1	25	φ25	φ26.41	23	φ6	φ20	8	13	14.70	11.21	5.3	2-M4	4	48°51'	φ15.0	5.2
M1D 30 - 2608	1	30	φ30	φ31.41	26	φ8	φ22	8.9	14.5	15.89	11.71	6.2	-	-	47°42'	φ19.4	8.3
M1D 30 * 2608	1	30	φ30	φ31.41	26	φ8	φ22	8.9	14.5	15.89	11.71	6.2	2-M4	4.5	47°42'	φ19.4	8.1
M1.5D 20 - 2810	1	20	φ30	φ32.12	28	φ10	φ24	10	16.5	18.53	14.06	6.8	-	-	49° 3'	φ17.7	9.9
M1.5D 20 * 2810	1	20	φ30	φ32.12	28	φ10	φ24	10	16.5	18.53	14.06	6.8	2-M5	5	49° 3'	φ17.7	9.6
M1.5D 25 * 3410	1	25	φ37.5	φ39.62	34	φ10	φ30	11.5	19	21.26	16.31	7.5	2-M5	5.5	48°51'	φ23.8	17.5
M1.5D 30 - 3812	1	30	φ45	φ47.12	38	φ12	φ33	12.34	21	22.83	16.56	9.3	-	-	47°42'	φ29.6	27.3
M1.5D 30 * 3812	1	30	φ45	φ47.12	38	φ12	φ33	12.34	21	22.83	16.56	9.3	2-M5	6.5	47°42'	φ29.6	26.8

機械加工品 黄銅ブッシュ入り (下記参照) Machined Gear with Brass Bush

M1.5DB 20 - 3295	1	20	φ30	φ32.12	32	φ9.5(H8)	φ24	14	20	22	18.06	6	-	-	49° 3'	φ19.0	29.6
------------------	---	----	-----	--------	----	----------	-----	----	----	----	-------	---	---	---	--------	-------	------

【*】 (アスタ) にはセットスクリーが2個付いております。
【*】 : Gear with two threaded holes / with two set screws.

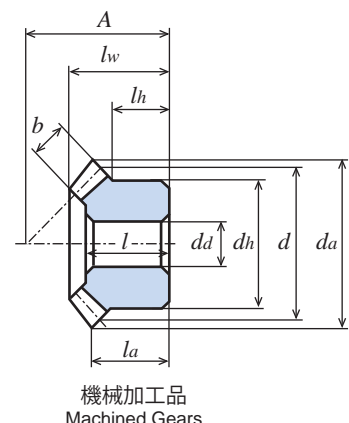
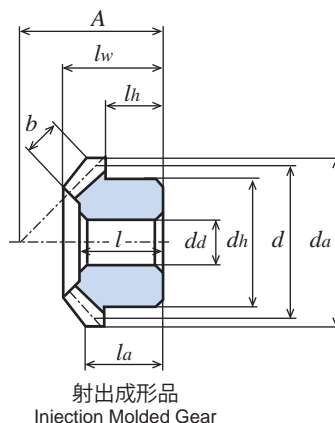
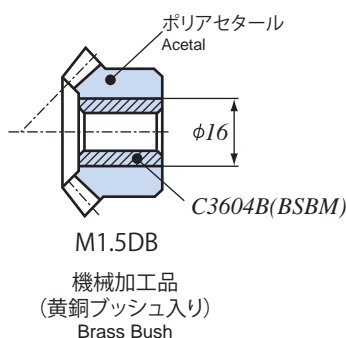



御注文には必ず“フルネームで商品記号”を明記してください。
Please refer to the catalogue reference while ordering.
 d_s の寸法は参考値です。
Dimension of d_s is for reference only.

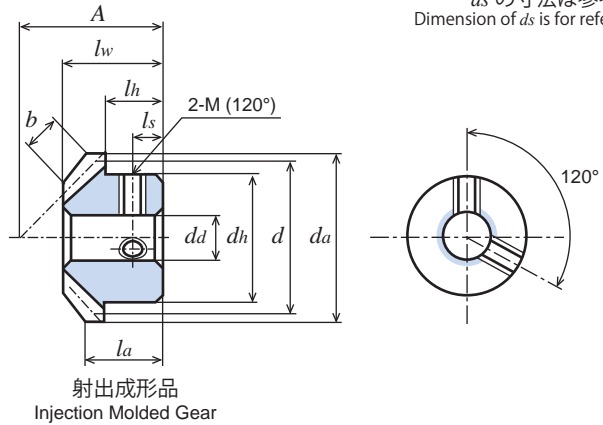

SUS304L ステンレス
Material : Stainless Steel SUS304L

単位 : mm
Dimensions : mm

商品記号 Catalogue Number	モジュール Module m	歯数 Number of Teeth z	基準円直径 Pitch Diameter d	歯先円直径 Tip Diameter d_a	組立距離 Locating Distance A	穴径 Bore Diameter $da(H8)$	ハブ外径 Hub Diameter dh	ハブ長さ Hub Projection lh	全長 Overall Length lw	全長 Tip Distance la	歯幅 Face Width b	ねじ Set Screw		歯先角 Face Angle δ_a	重量 Weight $W(g)$
												$2-M(120^\circ)$	l_s		
M50SUM 20 * 1103	0.5	20	$\phi 10$	$\phi 10.70$	11	$\phi 3$	$\phi 8$	4.25	8	6.35	2.5	2-M2.5	2.5	49°48'	2.6
M80SUM 20 * 1605	0.8	20	$\phi 16$	$\phi 17.13$	16	$\phi 5$	$\phi 12$	4.5	10.96	8.57	3.7	2-M3	2.5	49°48'	10.2
M1SUM 20 * 2106	1.0	20	$\phi 20$	$\phi 21.41$	21	$\phi 6$	$\phi 16$	7.5	14.49	11.71	4.3	2-M4	4.5	49°48'	22.0

モジュールサイズは呼称値となります。
成形加工での収縮率により若干寸法が異なります。
他の商品との組み合わせでの使用は出来ません。
MIM マイタギヤ同志で組み合わせてご使用下さい。

Module size of MIM miter gear is value of diminutive.
Some of dimensions differ from shrinkage ratio in the forming process.
MIM miter gear match with MIN miter gear only.

MIM シリーズの特徴 (METAL INJECTION MOLDING)

- ・金属射出成形法です。
- ・セットスクリューは付いておりません。

追加加工時は、歯先円をチャッキングして下さい。
追加加工をすると気泡 (す) がでることがあります。

Feature of MIM miter gear
Method of metal injection molding
Gear with threaded hole/without set screw
Please chuck the tip circle when additional machine work to the gear.
The void may be appeared when additional machine work to the gear.

許容伝達動力表 (W) 曲げ強さ

Allowable transfer capability table (W) Bending Strength

商品記号 Catalogue Numbers	回転速度 (min ⁻¹) revolution/min (min ⁻¹) of Bevel gears					
	100	200	400	600	800	1,000
M50SUM 20	0.5	1.1	2.2	3.3	4.4	5.6
M80SUM 20	2.1	4.3	8.7	13.1	17.5	21.9
M1SUM 20	3.7	7.6	15.3	22.9	30.6	37.8

許容伝達動力は当社耐久試験による実験値です。
Allowable transfer capabilities are experiment value by our endurance test.
動力の換算式は P26 をご参照ください。
Please refer to the conversion formulas of power on page P26.

材質別 強度比較の目安

Comparison table (material/strength)

材質	強度比較	
S45C	1	1.67
SUS304	0.6	1
MIM (SUS304)	0.4	0.67

SUS マイタギヤ

SUS MITER GEARS

モジュール **0.8/1/**
MODULE

圧力角 20° 歯数比 1 : 1
1 : 1 Ratio 20° PRESSURE ANGLE

JIS B1704 4級
System of accuracy : JIS B1704 Class 4



New **ねじを2箇所 (120°配) にしました。**
締結力が1.6倍になりました。
New item with two threaded holes (120°)
Tightening power increased by 1.6 times.

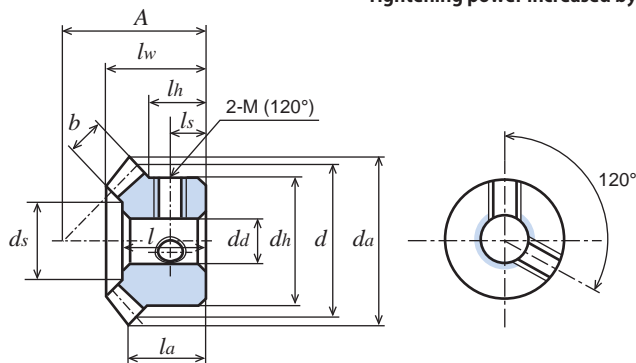

SUS304 ステンレス鋼棒 (JIS G 4303)

Material : Stainless Steel SUS304 (JIS G 4303)

単位 : mm
Dimensions : mm

商品記号 Catalogue Number	歯数比 Ratio	歯数 Number of Teeth	基準円直径 Reference Diameter	歯先円直径 Tip Diameter	組立距離 Locating Distance	穴径 Bore Diameter	ハブ外径 Hub Diameter	ハブ長さ Hub Projection	穴長さ Bore Length	全長 Overall Length	Tip Distance	歯幅 Face Width	ねじ Set Screw		歯先角 Face Angle	歯先角 Face Angle	重量 Weight
													2-M(120°)	ls			
M80SU 20 - 1605	1	20	φ16	φ17.13	16	φ5	φ12	6	10	11	8.57	3.7	-	-	49° 3'	φ 9.5	8.9
M80SU 20 * 1605	1	20	φ16	φ17.13	16	φ5	φ12	6	10	11	8.57	3.7	2-M3	3	49° 3'	φ 9.5	8.5
M80SU 25 - 1805	1	25	φ20	φ21.13	18	φ5	φ16	6	10.5	11.67	8.57	4.7	-	-	48°51'	φ11.7	17.3
M80SU 25 * 1805	1	25	φ20	φ21.13	18	φ5	φ16	6	10.5	11.67	8.57	4.7	2-M3	3	48°51'	φ11.7	16.8
M80SU 30 - 2006	1	30	φ24	φ25.13	20	φ6	φ18	6	11	12.34	8.57	5.6	-	-	47°42'	φ14.1	24.8
M80SU 30 * 2006	1	30	φ24	φ25.13	20	φ6	φ18	6	11	12.34	8.57	5.6	2-M4	3.5	47°42'	φ14.1	23.8
M1SU 20 - 2106	1	20	φ20	φ21.41	21	φ6	φ16	9	13	14.53	11.71	4.3	-	-	49° 3'	φ11.8	19.9
M1SU 20 * 2106	1	20	φ20	φ21.41	21	φ6	φ16	9	13	14.53	11.71	4.3	2-M4	4.5	49° 3'	φ11.8	19.1
M1SU 25 - 2306	1	25	φ25	φ26.41	23	φ6	φ20	8	13	14.70	11.21	5.3	-	-	48°51'	φ15.0	34.1
M1SU 25 * 2306	1	25	φ25	φ26.41	23	φ6	φ20	8	13	14.70	11.21	5.3	2-M4	4	48°51'	φ15.0	32.9
M1SU 30 - 2608	1	30	φ30	φ31.41	26	φ8	φ22	8.9	14.5	15.89	11.71	6.2	-	-	47°42'	φ19.4	47
M1SU 30 * 2608	1	30	φ30	φ31.41	26	φ8	φ22	8.9	14.5	15.89	11.71	6.2	2-M5	4.5	47°42'	φ19.4	45.2

●の商品は新商品です。
Products with ● marks are new item.

SUS304の商品にはセットスクリューは付いておりません。
[*]: Gear with two threaded holes / without set screw.

許容伝達動力表 (W) 曲げ強さ

Allowable transfer capability table (W) Bending Strength

商品記号 Catalogue Numbers	回転速度 (min ⁻¹) revolution/min						
	10	100	200	400	600	800	1,000
M80SU 20	0.2	2.7	5.5	11.0	16.5	22.0	27.5
M80SU 25	0.4	4.6	9.3	18.7	28.1	37.5	46.6
M80SU 30	0.7	7.1	14.2	28.4	42.6	56.8	68.6
M1SU 20	0.5	5.1	10.2	20.5	30.8	41.1	51.0
M1SU 25	0.8	8.5	17.1	34.3	51.5	68.3	82.4
M1SU 30	1.2	12.8	25.6	51.3	77.0	99.3	119.2

材質 SUS304 の許容伝達動力は参考値となります。

The above numerical value are reference value.

動力の換算式は P26 をご参照ください。

Please refer to the conversion formulas of power on page P26.

SUS マイタギヤ

SUS MITER GEARS

モジュール
MODULE

1.5/2/2.5/3

圧力角 20° 歯数比 1:1
1:1 Ratio 20° PRESSURE ANGLE

JIS B1704 4級
System of accuracy : JIS B1704 Class 4



御注文には必ず“フルネームで商品記号”を明記してください。
Please refer to the catalogue reference while ordering.
 d_s の寸法は参考値です。
Dimension of d_s is for reference only.

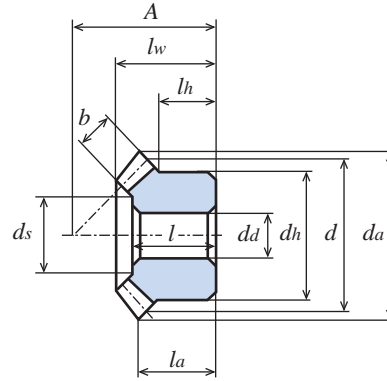

SUS304 ステンレス鋼棒 (JIS G 4303)

Material : Stainless Steel SUS304 (JIS G 4303)

単位 : mm
Dimensions : mm

商品記号 Catalogue Number	歯数比 Ratio u	歯数 Number of Teeth z	基準円直径 Reference Diameter d	歯先円直径 Tip Diameter d_a	組立距離 Locating Distance A	穴径 Bore Diameter $d_d(H8)$	ハブ外径 Hub Diameter d_h	ハブ長さ Hub Projection l_h	穴長さ Bore Length l	全長 Overall Length l_w	先端距離 Tip Distance l_a	歯幅 Face Width b	ねじ Set Screw		歯先角 Face Angle δ_a	歯先角 Face Angle d_s	重量 Weight $W(g)$
													M	l_s			
M1.5SU 20 - 2810	1	20	$\phi 30$	$\phi 32.12$	28	$\phi 10$	$\phi 24$	10	16.5	18.53	14.06	6.8	-	-	49° 3'	$\phi 17.7$	55.4
M1.5SU 25 - 3410	1	25	$\phi 37.5$	$\phi 39.62$	34	$\phi 10$	$\phi 30$	11.5	19	21.26	16.31	7.5	-	-	48° 51'	$\phi 23.7$	107.6
M1.5SU 30 - 3812	1	30	$\phi 45$	$\phi 47.12$	38	$\phi 12$	$\phi 33$	12.34	21	22.83	16.56	9.3	-	-	47° 42'	$\phi 29.6$	153.6
M2SU 20 - 3712	1	20	$\phi 40$	$\phi 41.32$ <small>($\phi 42.83$)</small>	37	$\phi 12$	$\phi 34$	14	21	24	18.41	8.5	-	-	49° 3'	$\phi 23.9$	142.5
M2SU 25 - 4012	1	25	$\phi 50$	$\phi 51.33$ <small>($\phi 52.83$)</small>	40	$\phi 12$	$\phi 42$	11	21	23.34	17.07	10.5	-	-	48° 51'	$\phi 32.3$	229.6
M2SU 30 - 5116	1	30	$\phi 60$	$\phi 61.36$ <small>($\phi 62.83$)</small>	51	$\phi 16$	$\phi 44$	16.79	28	30.77	22.41	12.4	-	-	47° 42'	$\phi 38.9$	364.9
M2.5SU 20 - 4814	1	20	$\phi 50$	$\phi 51.66$ <small>($\phi 53.54$)</small>	48	$\phi 14$	$\phi 42$	19	28	32.06	24.77	11.1	-	-	49° 3'	$\phi 28.5$	297.0
M3SU 20 - 5816	1	20	$\phi 60$	$\phi 61.99$ <small>($\phi 64.24$)</small>	58	$\phi 16$	$\phi 50$	23	35	39.06	30.12	13.6	-	-	49° 3'	$\phi 35.5$	525.6

許容伝達動力表 (W) 曲げ強さ

Allowable transfer capability table (W) Bending Strength

商品記号 Catalogue Numbers	回転速度 (min ⁻¹) revolution/min						
	10	100	200	400	600	800	1,000
M1.5SU 20 - 2810	1.7	17.9	35.8	71.7	107.6	138.6	166.4
M1.5SU 25 - 3410	2.7	27.9	55.8	111.6	163.5	207.2	246.7
M1.5SU 30 - 3812	4.3	43.3	86.7	173.4	246.3	309.5	365.9
M2SU 20 - 3712	4.0	40.8	81.6	163.2	236.5	298.9	355.1
M2SU 25 - 4012	6.7	67.0	134.0	268.0	402.1	536.1	670.1
M2SU 30 - 5116	10.2	102.7	205.5	397.2	550.3	681.6	803.6
M2.5SU 20 - 4814	8.1	81.9	163.9	325.8	456.3	570.6	671.6
M3SU 20 - 5816	14.3	143.5	287.0	554.6	768.4	951.7	1122.0

材質 SUS304 の許容伝達動力は参考値となります。

The above numerical value are reference value.

動力の換算式は P26 をご参照ください。

Please refer to the conversion formulas of power on page P26.

目次
CONTENTS

インフォメーション
INFORMATION

ギヤボックス
GEAR BOXES

ノーバッキングバックラッシュギヤ
ANTI BACKLASH SPUR GEARS

歯研歯車
GROUND SPUR GEARS

平歯車
SPUR GEARS

内歯車
INTERNAL GEARS

歯車ラック
GROUND RACKS

ラック
RACKS

へリカル・スクリューギヤ
HELICAL GEARS AND SCREW GEARS

ウォーム・ウォームギヤ
WORMS AND WORM GEARS

かなめ歯車
BEVEL GEARS

スプロケット
SPROCKETS

技術資料
REFERENCE DATA

SUS ベベルギヤ

SUS BEVEL GEARS

モジュール **0.8/1/1.5/2** 圧力角 20° 歯数比 1:2
 MODULE 1:2 Ratio 20° PRESSURE ANGLE

JIS B1704 4級
 System of accuracy : JIS B1704 Class 4



New **ねじを2箇所 (120°配) にしました。**
締結力が1.6倍になりました。
 New item with two threaded holes (120°)
 Tightening power increased by 1.6 times.

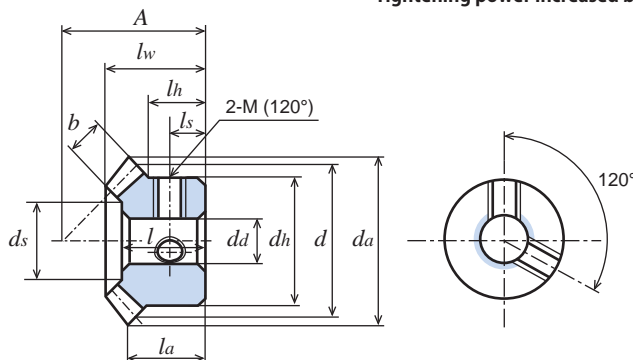

SUS304 ステンレス鋼棒 (JIS G 4303)

Material : Stainless Steel SUS304 (JIS G 4303)

単位 : mm
 Dimensions : mm

商品記号 Catalogue Number	歯数比 Ratio u	歯数 Number of Teeth z	基準円直径 Reference Diameter d	歯先円直径 Tip Diameter da	組立距離 Locating Distance A	穴径 Bore Diameter da(H8)	ハブ外径 Hub Diameter dh	ハブ長さ Hub Projection lh	穴長さ Bore Length l	全長 Overall Length lw	歯幅 Face Width b	ねじ Set Screw		歯先角 Face Angle		重量 Weight W(g)	
												2-M(120°)	ls	δa	ds		
B80SU 20-5	2	20	φ16	φ17.43	22.5	φ5	φ12	5.5	10	10.79	6.86	4.5	-	-	29° 8'	φ9.8	9.2
B80SU 40-6	2	40	φ32	φ32.72	16.46	φ6	φ20	6	9.5	11.01	9.18	4.5	-	-	66° 0'	φ22.9	34.4
B80SU 20*5	2	20	φ16	φ17.43	22.5	φ5	φ12	5.5	10	10.79	6.86	4.5	2-M3	2.5	29° 8'	φ9.8	8.8
B80SU 40*6	2	40	φ32	φ32.72	16.46	φ6	φ20	6	9.5	11.01	9.18	4.5	2-M4	3.5	66° 0'	φ22.9	33.2
B1SU 20-6	2	20	φ20	φ21.79	29.6	φ6	φ16	8.6	14	15.03	10.05	5.7	-	-	29° 8'	φ12.1	21.6
B1SU 40-8	2	40	φ40	φ40.89	21.8	φ8	φ25	8	13	15.02	12.69	5.7	-	-	66° 0'	φ28.4	72.6
B1SU 20*6	2	20	φ20	φ21.79	29.6	φ6	φ16	8.6	14	15.03	10.05	5.7	2-M4	4	29° 8'	φ12.1	20.8
B1SU 40*8	2	40	φ40	φ40.89	21.8	φ8	φ25	8	13	15.02	12.69	5.7	2-M5	4	66° 0'	φ28.4	70.4
B1.5SU 18-8	2	18	φ27	φ29.68	40.74	φ8	φ22	12.5	21	22.96	14.41	9.8	-	-	29°25'	φ12.1	60.0
B1.5SU 36-10	2	36	φ54	φ55.34	26.75	φ10	φ30	10	15.5	18.54	14.59	9.8	-	-	66°17'	φ34.3	141.3
B2SU 18-10	2	18	φ36	φ37.81 ^(φ39.58)	53.12	φ10	φ28	15.12	27	29	18.01	12.6	-	-	29°25'	φ19.1	131.0
B2SU 36-12	2	36	φ72	φ72.15 ^(φ73.79)	35.21	φ12	φ36	13	21	24.07	19	12.6	-	-	66°17'	φ47.6	316.2

●の商品は新商品です。
 Products with ● marks are new item.

SUS304の商品にはセットスクリューは付いておりません。
 [*] : Gear with two threaded holes / without set screw.

許容伝達動力表 (W) 曲げ強さ

Allowable transfer capability table (W) Bending Strength

商.品記号 Catalogue Numbers	回転速度 (min ⁻¹) revolution/min						
	10	100	200	400	600	800	1,000
B80SU 20	0.3	3.5	7.0	14.1	21.1	28.2	35.2
B1SU 20	0.6	6.9	13.9	27.8	41.7	55.6	69.1
B1.5SU 18-8	2.1	21.3	42.7	85.5	128.3	168.1	202.5
B2SU 18-10	4.9	49.5	99.1	198.3	292.2	370.9	442.4

材質 SUS304 の許容伝達動力は参考値となります。
 The above numerical value are reference value.
 動力の換算式は P26 をご参照ください。
 Please refer to the conversion formulas of power on page P26.

JIS B1704 4級
System of accuracy : JIS B1704 Class 4



御注文には必ず“フルネームで商品記号”を明記してください。

Please refer to the catalogue reference while ordering.

d_s の寸法は参考値です。
Dimension of d_s is for reference only.

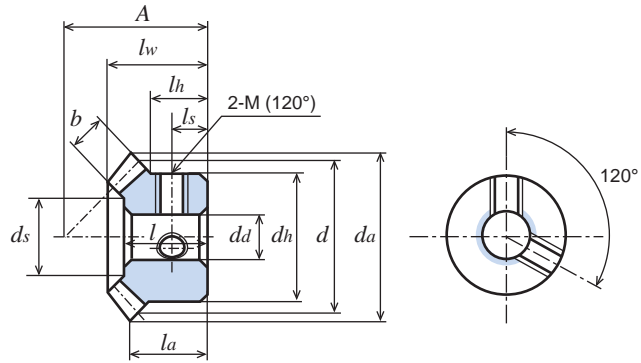

C3604B 快削黄銅棒

Material : Brass (ISO CuZn39Pb3)

単位 : mm
Dimensions : mm

商品記号 Catalogue Number	歯数比 Ratio u	歯数 Number of Teeth z	基準円直径 Reference Diameter d	歯先円直径 Tip Diameter d_a	組立距離 Locating Distance A	穴径 Bore Diameter $d_d(H8)$	ハブ外径 Hub Diameter d_h	ハブ長さ Hub Projection l_h	穴長さ Bore Length l	全長 Overall Length l_w	全長 Tip Distance l_a	歯幅 Face Width b	ねじ Set Screw		歯先角 Face Angle δ_a	d_s	重量 Weight $W(g)$
													$2-M(120^\circ)$	l_s			
M50B 20 - 1103	1	20	φ10	φ10.71	11	φ3	φ8	5	7	8	6.35	2.5	-	-	49° 3'	φ4.9	2.9
M50B 20 * 1103	1	20	φ10	φ10.71	11	φ3	φ8	5	7	8	6.35	2.5	2-M2.5	2.5	49° 3'	φ4.9	2.7
M50B 25 * 1204	1	25	φ12.5	φ13.21	12	φ4	φ11	5	7	8.11	6.10	3.0	2-M3	3	48° 14'	φ6.5	4.9
M50B 30 * 1404	1	30	φ15	φ15.71	14	φ4	φ12	5	8	9.21	6.85	3.5	2-M3	3	47° 42'	φ9.1	7.6
B50B 20	2	20	φ10	φ10.89	15.52	φ3	φ8	5	8	8.54	5.74	3.2	-	-	29° 8'	φ5.6	3.2
B50B 40	2	40	φ20	φ20.45	10.56	φ4	φ12	4	6.3	7.31	6.01	3.2	-	-	66° 0'	φ13.5	8.9
B50B 20 * 3	2	20	φ10	φ10.89	15.52	φ3	φ8	5	8	8.54	5.74	3.2	2-M2.5	2.5	29° 8'	φ5.6	3.0
B50B 40 * 4	2	40	φ20	φ20.45	10.56	φ4	φ12	4	6.3	7.31	6.01	3.2	2-M3	2	66° 0'	φ13.5	8.5

M80B 20 - 1605	1	20	φ16	φ17.13	16	φ5	φ12	6	10	11	8.57	3.7	-	-	49° 3'	φ9.5	9.4
M80B 20 * 1605	1	20	φ16	φ17.13	16	φ5	φ12	6	10	11	8.57	3.7	2-M3	3	49° 3'	φ9.5	9.1
M80B 25 * 1805	1	25	φ20	φ21.13	18	φ5	φ16	6	10.5	11.67	8.57	4.7	2-M3	3	48° 51'	φ11.7	16.3
M80B 30 * 2006	1	30	φ24	φ25.13	20	φ6	φ18	6	11	12.34	8.57	5.6	2-M4	3.5	47° 42'	φ14.1	22.2
B80B 20	2	20	φ16	φ17.43	22.5	φ5	φ12	5.5	10	10.79	6.86	4.5	-	-	29° 8'	φ9.8	9.8
B80B 40	2	40	φ32	φ32.72	16.46	φ6	φ20	6	9.5	11.01	9.18	4.5	-	-	66° 0'	φ22.9	36.1
B80B 20 * 5	2	20	φ16	φ17.43	22.5	φ5	φ12	5.5	10	10.79	6.86	4.5	2-M3	3	29° 8'	φ9.8	9.5
B80B 40 * 6	2	40	φ32	φ32.72	16.46	φ6	φ20	6	9.5	11.01	9.18	4.5	2-M4	3	66° 0'	φ22.9	34.9

M1B 20 * 2106	1	20	φ20	φ21.41	21	φ6	φ16	9	13	14.53	11.71	4.3	2-M4	4.5	49° 3'	φ11.8	18.1
M1B 25 * 2306	1	25	φ25	φ26.41	23	φ6	φ20	8	13	14.70	11.21	5.3	2-M4	4	48° 51'	φ15.0	31.5
M1B 30 * 2608	1	30	φ30	φ31.41	26	φ8	φ22	8.9	14.5	15.89	11.71	6.2	2-M5	4.5	47° 42'	φ19.4	43.0

【*】(アスタ)にはセットスクリーンが2個付いております。

【*】: Gear with two threaded holes / with two set screws.

RoHS 対応

2006年11月生産開始日より欧州 RoHS 指令に対応できる商品を提供しています。

We supplied the KG-products with RoHS compliance of EU to all our valued customers since November 2006

マイタギヤ / ベベルギヤ MITER AND BEVEL GEARS

モジュール **0.5**
MODULE

圧力角 20° 歯数比 1:1、1:2
1:1 and 1:2 Ratio 20° PRESSURE ANGLE

JIS B1704 3級
System of accuracy : JIS B1704 Class 3



New **ねじを2箇所 (120°配) にしました。**
New item with two threaded holes (120°)

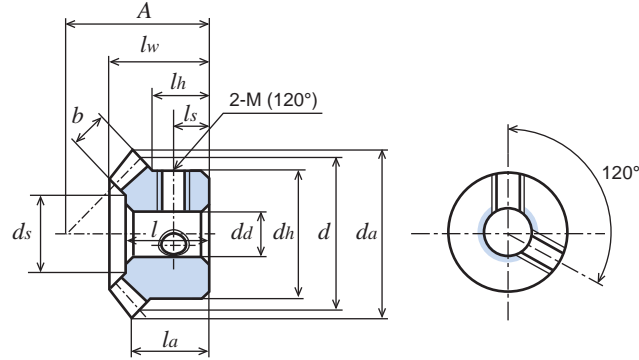

S45C 機械構造用炭素鋼 (JIS G 4051)
Material : Carbon Steel (ISO C45)

単位 : mm
Dimensions : mm

商品記号 Catalogue Number	歯数比 Ratio <i>u</i>	歯数 Number of Teeth <i>z</i>	基準円直径 Reference Diameter <i>d</i>	歯先円直径 Tip Diameter <i>da</i>	組立距離 Locating Distance <i>A</i>	穴径 Bore Diameter <i>da(H8)</i>	ハブ外径 Hub Diameter <i>dh</i>	ハブ長さ Hub Projection <i>lh</i>	穴長さ Bore Length <i>l</i>	全長 Overall Length <i>lw</i>	全長 Overall Length <i>la</i>	歯幅 Face Width <i>b</i>	ねじ Set Screw		歯先角 Face Angle <i>da</i>	<i>ds</i>	重量 Weight <i>W(g)</i>
													2-M(120°)	<i>ls</i>			
M50S 20 - 1103	1	20	φ10	φ10.71	11	φ3	φ8	5	7	8	6.35	2.5	-	-	49° 3'	φ4.9	2.7
M50S 25 - 1204	1	25	φ12.5	φ13.21	12	φ4	φ11	5	7	8.11	6.10	3.0	-	-	48° 14'	φ6.5	5.2
M50S 30 - 1404	1	30	φ15	φ15.71	14	φ4	φ12	5	8	9.21	6.85	3.5	-	-	47° 42'	φ9.1	7.4
M50S 20 * 1103	1	20	φ10	φ10.71	11	φ3	φ8	5	7	8	6.35	2.5	2-M2.5	2.5	49° 3'	φ4.9	2.5
M50S 25 * 1204	1	25	φ12.5	φ13.21	12	φ4	φ11	5	7	8.11	6.10	3.0	2-M3	3	48° 14'	φ6.5	4.6
M50S 30 * 1404	1	30	φ15	φ15.71	14	φ4	φ12	5	8	9.21	6.85	3.5	2-M3	3	47° 42'	φ9.1	7.0
B50S 20	2	20	φ10	φ10.89	15.52	φ3	φ8	5	8	8.54	5.74	3.2	-	-	29° 8'	φ5.6	3.0
B50S 40	2	40	φ20	φ20.45	10.56	φ4	φ12	4	6.3	7.31	6.01	3.2	-	-	66° 0'	φ13.5	8.2
B50S 20 * 3	2	20	φ10	φ10.89	15.52	φ3	φ8	5	8	8.54	5.74	3.2	2-M2.5	2.5	29° 8'	φ5.6	2.8
B50S 40 * 4	2	40	φ20	φ20.45	10.56	φ4	φ12	4	6.3	7.31	6.01	3.2	2-M3	2	66° 0'	φ13.5	7.8

● の商品は新商品です。
Products with ● marks are new item.

【*】 (アスタ) にはセットスクリーが2個付いております。
[*] : Gear with two threaded holes / with two set screws.

許容伝達動力表 (W) 曲げ強さ

Allowable transfer capability table (W) Bending Strength

商品記号 Catalogue Numbers	回転速度 (min ⁻¹) revolution/min						
	10	100	200	400	600	800	1,000
M50S 20	0.1	1.5	3.1	6.2	9.3	12.4	15.5
M50S 25	0.2	2.5	5.0	10.0	15.0	20.1	25.1
M50S 30	0.3	3.8	7.6	15.2	22.9	30.5	38.1
B50S 20	0.2	2.0	4.1	8.2	12.4	16.5	20.7

The above numerical values are equivalent to JGMA formulas as reference only.
動力の換算式は P26 をご参照ください。
Please refer to the conversion formulas of power on page P26.

マイタギヤ / ベベルギヤ MITER AND BEVEL GEARS

モジュール **0.8**
MODULE

圧力角 20° 歯数比 1:1, 1:2
1:1 and 1:2 Ratio 20° PRESSURE ANGLE

JIS B1704 3級
System of accuracy: JIS B1704 Class 3



御注文には必ず“フルネームで商品記号”を明記してください。
Please refer to the catalogue reference while ordering.
 d_s の寸法は参考値です。
Dimension of d_s is for reference only.

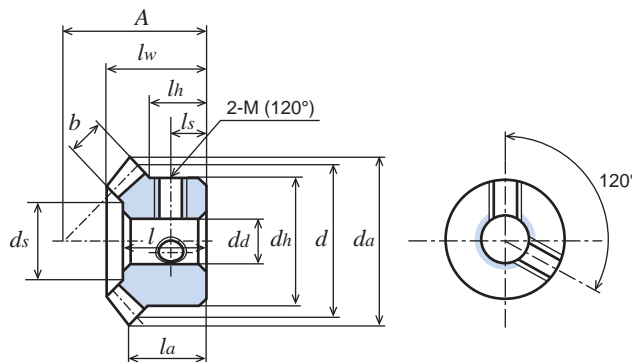

S45C 機械構造用炭素鋼 (JIS G 4051) Material: Carbon Steel (ISO C45)

単位: mm
Dimensions: mm

商品記号 Catalogue Number	歯数比 Ratio u	歯数 Number of Teeth z	基準円直径 Reference Diameter d	歯先円直径 Tip Diameter d_a	組立距離 Locating Distance A	穴径 Bore Diameter $d_d(H7)$	ハブ外径 Hub Diameter d_h	ハブ長さ Hub Projection l_h	穴長さ Bore Length l	全長 Overall Length l_w	全長 Tip Distance l_a	歯幅 Face Width b	ねじ Set Screw		歯先角 Face Angle δ_a	d_s	重量 Weight $W(g)$
													2-M(120°)	l_s			
M80S 20 - 1605	1	20	$\phi 16$	$\phi 17.13$	16	$\phi 5$	$\phi 12$	6	10	11	8.57	3.7	-	-	49° 3'	$\phi 9.5$	8.7
M80S 25 - 1805	1	25	$\phi 20$	$\phi 21.13$	18	$\phi 5$	$\phi 16$	6	10.5	11.67	8.57	4.7	-	-	48° 51'	$\phi 11.7$	16.8
M80S 30 - 2006	1	30	$\phi 24$	$\phi 25.13$	20	$\phi 6$	$\phi 18$	6	11	12.34	8.57	5.6	-	-	47° 42'	$\phi 14.1$	24.1
M80S 20 * 1605	1	20	$\phi 16$	$\phi 17.13$	16	$\phi 5$	$\phi 12$	6	10	11	8.57	3.7	2-M3	3	49° 3'	$\phi 9.5$	8.4
M80S 25 * 1805	1	25	$\phi 20$	$\phi 21.13$	18	$\phi 5$	$\phi 16$	6	10.5	11.67	8.57	4.7	2-M3	3	48° 51'	$\phi 11.7$	16.3
M80S 30 * 2006	1	30	$\phi 24$	$\phi 25.13$	20	$\phi 6$	$\phi 18$	6	11	12.34	8.57	5.6	2-M4	3	47° 42'	$\phi 14.1$	23.1
B80S 20	2	20	$\phi 16$	$\phi 17.43$	22.5	$\phi 5$	$\phi 12$	5.5	10	10.79	6.86	4.5	-	-	29° 8'	$\phi 9.8$	9.0
B80S 40	2	40	$\phi 32$	$\phi 32.72$	16.46	$\phi 6$	$\phi 20$	6	9.5	11.01	9.18	4.5	-	-	66° 0'	$\phi 22.9$	33.4
B80S 20 * 5	2	20	$\phi 16$	$\phi 17.43$	22.5	$\phi 5$	$\phi 12$	5.5	10	10.79	6.86	4.5	2-M3	2.75	29° 8'	$\phi 9.8$	8.7
B80S 40 * 6	2	40	$\phi 32$	$\phi 32.72$	16.46	$\phi 6$	$\phi 20$	6	9.5	11.01	9.18	4.5	2-M4	3	66° 0'	$\phi 22.9$	32.3

【*】(アスタ)にはセットスクリューが2個付いております。

【*】: Gear with two threaded holes / with two set screws.

許容伝達動力表 (W) 曲げ強さ

Allowable transfer capability table (W) Bending Strength

商品記号 Catalogue Numbers	回転速度 (min ⁻¹) revolution/min						
	10	100	200	400	600	800	1,000
M80S 20	0.6	6.0	12.1	24.2	36.3	48.4	60.6
M80S 25	1.0	10.3	20.6	41.3	61.9	82.6	103.3
M80S 30	1.5	15.6	31.2	62.5	93.8	124.9	156.2
B80S 20	0.7	7.7	15.5	31.0	46.5	62.0	77.6

The above numerical values are equivalent to JGMA formulas as reference only.

動力の換算式は P26 を参照ください。

Please refer to the conversion formulas of power on page P26.

- 目次 CONTENTS
- インフォメーション INFORMATION
- ギヤボックス GEAR BOXES
- ノーバッキングギヤ ANTI BACKLASH SPUR GEARS
- 歯研歯車 GROUND SPUR GEARS
- 平歯車 SPUR GEARS
- 内歯車 INTERNAL GEARS
- 歯研ラック GROUND RACKS
- ラック RACKS
- へリカル・スクリューギヤ HELICAL GEARS AND SCREW GEARS
- ウォーム・ウォームギヤ WORMS AND WORM GEARS
- ベベルギヤ BEVEL GEARS
- スプロケット SPROCKETS
- 技術資料 REFERENCE DATA

スパイラルマイタギヤ

SPIRAL MITER GEARS

モジュール 1
MODULE

圧力角 20° 歯数比 1:1 ねじれ角 35°
1:1 Ratio 20° PRESSURE ANGLE 35° SPIRAL ANGLE

JIS B1704 3級 (歯部高周波焼入品: 4級)
System of Accuracy: JIS B 1704 Class 3
(Induction hardened products: Class 4)



New **ねじを2箇所 (120°配) にしました。**
締結力が1.6倍になりました。
New item with two threaded holes (120°)
Tightening power increased by 1.6 times.

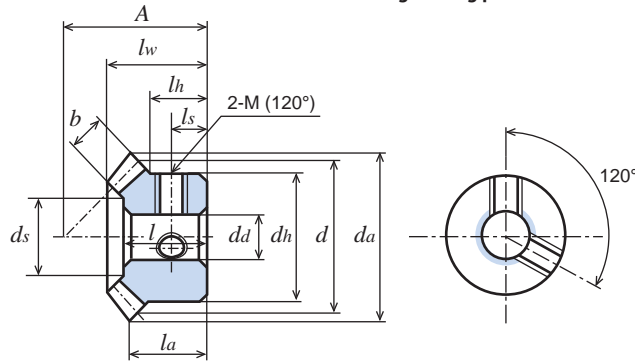

S45C 機械構造用炭素鋼 (JIS G 4051)
Material: Carbon Steel (ISO C45)

単位: mm
Dimensions: mm

商品記号 Catalogue Number	歯数比 Ratio <i>u</i>	歯数 Number of Teeth <i>z</i>	基準円直径 Reference Diameter <i>d</i>	歯先円直径 Tip Diameter <i>da</i>	組立距離 Locating Distance <i>A</i>	穴径 Bore Diameter <i>da</i> (H7)	ハブ外径 Hub Diameter <i>dh</i>	ハブ長さ Hub Projection <i>lh</i>	穴長さ Bore Length <i>l</i>	全長 Overall Length <i>lw</i>	全長 Overall Length <i>la</i>	歯幅 Face Width <i>b</i>	キーみぞ Key Way <i>b2 × t2</i>	ねじ Set Screw		歯先角 Face Angle		重量 Weight <i>W</i> (g)
														<i>M</i>	<i>ls</i>	<i>da</i>	<i>ds</i>	
M1S 20R - 2106	1	20	φ20	φ21.12	21	φ6	φ16	9	13	14.43	11.56	4.5	-	-	-	50°31'	φ11.3	19.7
M1S 20L - 2106	1	20	φ20	φ21.12	21	φ6	φ16	9	13	14.43	11.56	4.5	-	-	-	50°31'	φ11.3	19.7
M1S 20R * 2108	1	20	φ20	φ21.12	21	φ8	φ16	9	13	14.43	11.56	4.5	-	2-M4	4.5	50°31'	φ11.3	16.9
M1S 20L * 2108	1	20	φ20	φ21.12	21	φ8	φ16	9	13	14.43	11.56	4.5	-	2-M4	4.5	50°31'	φ11.3	16.9
M1S 30R - 2610	1	30	φ30	φ31.09	26	φ10	φ22	9	14.5	15.67	11.54	6.2	-	-	-	48°21'	φ19.4	43.0
M1S 30L - 2610	1	30	φ30	φ31.09	26	φ10	φ22	9	14.5	15.67	11.54	6.2	-	-	-	48°21'	φ19.4	43.0
M1S 30R * 2610	1	30	φ30	φ31.09	26	φ10	φ22	9	14.5	15.67	11.54	6.2	-	2-M5	4.5	48°21'	φ19.4	41.5
M1S 30L * 2610	1	30	φ30	φ31.09	26	φ10	φ22	9	14.5	15.67	11.54	6.2	-	2-M5	4.5	48°21'	φ19.4	41.5
M1S 30R * 2610H	1	30	φ30	φ31.09	26	φ10(H8)	φ22	9	14.5	15.67	11.54	6.2	-	2-M5	4.5	48°21'	φ19.4	41.5
M1S 30L * 2610H	1	30	φ30	φ31.09	26	φ10(H8)	φ22	9	14.5	15.67	11.54	6.2	-	2-M5	4.5	48°21'	φ19.4	41.5

●の商品は新商品です。
Products with ● marks are new item.

カタログ記号の末尾に【H】を付した商品は歯部高周波焼入済です。【H】: Gear tooth surface completed with induction hardening, Hardness HRC 47 to 53.
【*】 (アスタ) にはセットスクリューが2個付いております。【*】: Gear with two threaded holes / with two set screws.

	歯数比 Ratio	ピッチ角 Pitch Angle		軸角 Shaft Angle
マイタギヤ Miter gear	1:1	45°		90°
ベベルギヤ Bevel gear	1:2	ピニオン ギヤ Pinion Gear	26° 34' 63° 26'	90°
	1:3	ピニオン ギヤ Pinion Gear	18° 26' 71° 34'	90°

許容伝達動力表 (W) 曲げ強さ

Allowable transfer capability table (W) Bending Strength

商品記号 Catalogue Numbers	回転速度 (min ⁻¹) revolution/min						
	300	600	900	1,200	1,500	1,800	2,000
M1S 20R - 2106	34.9	69.9	104.9	134.6	161.0	185.2	200.2
M1S 30R * 2610	84.0	168.0	222.5	279.2	329.7	395.6	428.5
M1S 30R * 2610H	73.3	146.6	198.1	254.5	298.5	348.7	387.5

許容伝達動力表 (W) 歯面強さ

Allowable transfer capability table (W) Surface Durability

	回転速度 (min ⁻¹) revolution/min						
	300	600	900	1,200	1,500	1,800	2,000
	4.6	9.35	14.1	18.2	21.9	25.4	27.6
	16.1	32.5	49.1	58.7	69.9	80.3	87.7
	43.6	90.0	130.7	167.2	200.4	230.8	250.8

The above numerical values are equivalent to JGMA formulas as reference only.
動力の換算式は P26 をご参照ください。Please refer to the conversion formulas of power on page P26.

スパイラルベベルギヤ

SPIRAL BEVEL GEARS

モジュール 1
MODULE

圧力角 20° 歯数比 1:2、1:3 ねじれ角 35°
1:1 and 1:2 Ratio 20° PRESSURE ANGLE 35° SPIRAL ANGLE

JIS B1704 3級 (歯部高周波焼入品:4級)
System of Accuracy: JIS B 1704 Class 3
(Induction hardened products: Class 4)



御注文には必ず“フルネームで商品記号”を明記してください。
Please refer to the catalogue reference while ordering.
 d_s の寸法は参考値です。
Dimension of d_s is for reference only.

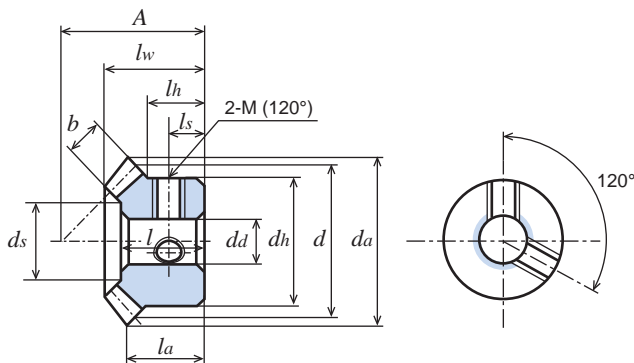

S45C 機械構造用炭素鋼 (JIS G 4051)

Material: Carbon Steel (ISO C45)

単位: mm
Dimensions: mm

商品記号 Catalogue Number	歯数比 Ratio u	歯数 Number of Teeth z	基準円直径 Reference Diameter d	歯先円直径 Tip Diameter d_a	組立距離 Locating Distance A	穴径 Bore Diameter $d_d(H7)$	ハブ外径 Hub Diameter d_h	ハブ長さ Hub Projection l_h	穴長さ Bore Length l	全長 Overall Length l_w	歯幅 Face Width b	ねじ Set Screw		歯先角 Face Angle δ_a	d_s	重量 Weight $W(g)$	
												M	l_s				
● B1S 20L - 8	2	20	$\phi 20$	$\phi 21.87$	29.6	$\phi 8$	$\phi 16$	8.6	14	15	10.07	5.7	-	-	30°13'	$\phi 12.1$	18.8
B1S 20L * 8	2	20	$\phi 20$	$\phi 21.87$	29.6	$\phi 8$	$\phi 16$	8.6	14	15	10.07	5.7	2-M4	4	30°13'	$\phi 12.1$	18.2
B1S 20L * 8H	2	20	$\phi 20$	$\phi 21.87$	29.6	$\phi 8(H8)$	$\phi 16$	8.6	14	15	10.07	5.7	2-M4	4	30°13'	$\phi 12.1$	18.2
● B1S 40R - 10	2	40	$\phi 40$	$\phi 40.41$	21.8	$\phi 10$	$\phi 25$	8	13	14.57	12.21	5.7	-	-	65°36'	$\phi 28.4$	66.9
B1S 40R * 10	2	40	$\phi 40$	$\phi 40.41$	21.8	$\phi 10$	$\phi 25$	8	13	14.57	12.21	5.7	2-M5	4	65°36'	$\phi 28.4$	65.1
B1S 40R * 10H	2	40	$\phi 40$	$\phi 40.41$	21.8	$\phi 10(H8)$	$\phi 25$	8	13	14.57	12.21	5.7	2-M5	4	65°36'	$\phi 28.4$	65.1
● B1S 15L - 6	3	15	$\phi 15$	$\phi 17.07$	31	$\phi 6$	$\phi 13$	8.17	14.4	15.07	8.85	6.7	-	-	21°53'	$\phi 8.0$	12.1
B1S 15L * 6	3	15	$\phi 15$	$\phi 17.07$	31	$\phi 6$	$\phi 13$	8.17	14.4	15.07	8.85	6.7	2-M4	4	21°53'	$\phi 8.0$	11.5
B1S 15L * 6H	3	15	$\phi 15$	$\phi 17.07$	31	$\phi 6(H8)$	$\phi 13$	8.17	14.4	15.07	8.85	6.7	2-M4	4	21°53'	$\phi 8.0$	11.5
● B1S 45R - 10	3	45	$\phi 45$	$\phi 45.25$	20	$\phi 10$	$\phi 25$	8	12.9	14.8	12.88	6.7	-	-	73°21'	$\phi 31.1$	80.6
B1S 45R * 10	3	45	$\phi 45$	$\phi 45.25$	20	$\phi 10$	$\phi 25$	8	12.9	14.8	12.88	6.7	2-M5	4	73°21'	$\phi 31.1$	78.8
B1S 45R * 10H	3	45	$\phi 45$	$\phi 45.25$	20	$\phi 10(H8)$	$\phi 25$	8	12.9	14.8	12.88	6.7	2-M5	4	73°21'	$\phi 31.1$	78.8

● の商品は新商品です。
Products with ● marks are new item.

カタログ記号の末尾に【H】を付した商品は歯部高周波焼入済です。【H】: Gear tooth surface completed with induction hardening, Hardness HRC 47 to 53.
【*】(アスタ)にはセットスクリューが2個付いております。【*】: Gear with two threaded holes / with two set screws.

許容伝達動力表 (W) 曲げ強さ

Allowable transfer capability table (W) Bending Strength

商品記号 Catalogue Numbers	回転速度 (min ⁻¹) revolution/min						
	300	600	900	1,200	1,500	1,800	2,000
B1S 20L * 8	46.5	93.0	139.5	179.1	214.1	246.3	266.3
B1S 20L * 8H	40.6	81.2	121.8	157.3	189.4	219.3	238.0
B1S 15L * 6	35.7	71.5	107.3	143.1	174.2	202.1	219.7
B1S 15L * 6H	31.2	62.4	93.7	124.9	152.8	178.2	194.4

The above numerical values are equivalent to JGMA formulas as reference only.

動力の換算式は P26 をご参照ください。Please refer to the conversion fomulas of power on page P26.

許容伝達動力表 (W) 歯面強さ

Allowable transfer capability table (W) Surface Durability

商品記号 Catalogue Numbers	回転速度 (min ⁻¹) revolution/min						
	300	600	900	1,200	1,500	1,800	2,000
B1S 20L * 8	7.9	16.0	24.2	31.3	36.4	42.7	47.5
B1S 20L * 8H	21.8	44.9	68.6	89.8	109.2	127.4	139.0
B1S 15L * 6	5.0	10.1	15.2	20.4	25.0	29.2	31.8
B1S 15L * 6H	13.8	28.6	43.7	59.0	72.9	85.7	93.9

目次
CONTENTS
インフォメーション
INFORMATION
ギヤボックス
GEAR BOXES
ノーマンバックラッシュギヤ
ANTI BACKLASH SPUR GEARS
歯研研歯車
GROUND SPUR GEARS
平歯車
SPUR GEARS
内歯車
INTERNAL GEARS
歯研ラック
GROUND RACKS
ラック
RACKS
ヘリカル・スクリューギヤ
HELICAL GEARS AND SCREW GEARS
ワーム・ワームホイール
WORMS AND WORM WHEELS
かなめ歯車
BEVEL GEARS
スプロケット
SPROCKETS
技術資料
REFERENCE DATA

スパイラルマイタギヤ

SPIRAL MITER GEARS

モジュール **1.5**
MODULE

圧力角 20° 歯数比 1:1 ねじれ角 35°
1:1 Ratio 20° PRESSURE ANGLE 35° SPIRAL ANGLE

JIS B1704 3級 (歯部高周波焼入品:4級)
System of Accuracy: JIS B 1704 Class 3
(Induction hardened products: Class 4)



New 仕様変更 締結加工不要。
Additional machining on tightening is not necessary.

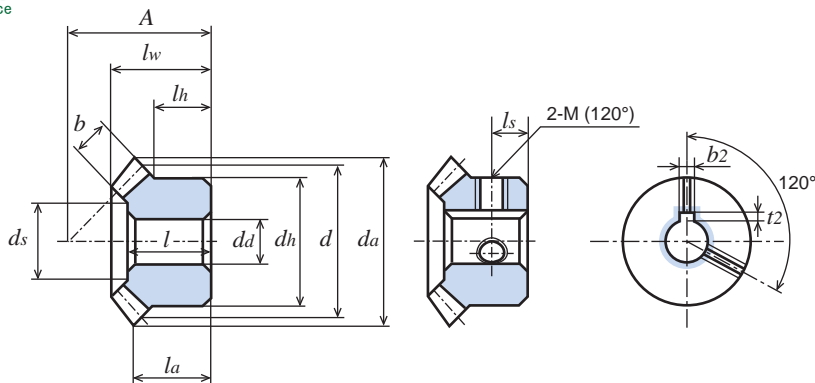

S45C 機械構造用炭素鋼 (JIS G 4051)

Material: Carbon Steel (ISO C45)

単位: mm
Dimensions: mm

商品記号 Catalogue Number	歯数比 Ratio <i>u</i>	歯数 Number of Teeth <i>z</i>	基準円直径 Reference Diameter <i>d</i>	歯先円直径 Tip Diameter <i>da</i>	組立距離 Locating Distance <i>A</i>	穴径 Bore Diameter <i>da(H7)</i>	ハブ外径 Hub Diameter <i>dh</i>	ハブ長さ Hub Projection <i>lh</i>	穴長さ Bore Length <i>l</i>	全長 Overall Length <i>lw</i>	Tip Distance <i>la</i>	歯幅 Face Width <i>b</i>	キミぞ Key Way <i>b2 × t2</i>	ねじ Set Screw		歯先角 Face Angle <i>δa</i>	歯先角 Face Angle <i>ds</i>	重量 Weight <i>W(g)</i>
														2-M	ls			
M1.5S 20R - 2810	1	20	φ30	φ31.85	28	φ10	φ24	10	16.5	18.44	13.93	7	-	-	-	50° 5'	φ17.2	54.7
M1.5S 20L - 2810	1	20	φ30	φ31.85	28	φ10	φ24	10	16.5	18.44	13.93	7	-	-	-	50° 5'	φ17.2	54.7
M1.5S 20R - 2810H	1	20	φ30	φ31.85	28	φ10(H8)	φ24	10	16.5	18.44	13.93	7	-	-	-	50° 5'	φ17.2	54.7
M1.5S 20L - 2810H	1	20	φ30	φ31.85	28	φ10(H8)	φ24	10	16.5	18.44	13.93	7	-	-	-	50° 5'	φ17.2	54.7
M1.5S 20R # 2810H	1	20	φ30	φ31.85	28	φ10(H8)	φ24	10	16.5	18.44	13.93	7	3 × 1.4	2-M4	5	50° 5'	φ17.2	54.1
M1.5S 20L # 2810H	1	20	φ30	φ31.85	28	φ10(H8)	φ24	10	16.5	18.44	13.93	7	3 × 1.4	2-M4	5	50° 5'	φ17.2	54.1
M1.5S 20R # 2812H	1	20	φ30	φ31.85	28	φ12(H8)	φ24	10	16.5	18.44	13.93	7	4 × 1.8	2-M4	5	50° 5'	φ17.2	49.1
M1.5S 20L # 2812H	1	20	φ30	φ31.85	28	φ12(H8)	φ24	10	16.5	18.44	13.93	7	4 × 1.8	2-M4	5	50° 5'	φ17.2	49.1

カタログ記号の末尾に【H】を付した商品は歯部高周波焼入済です。【H】: Gear tooth surface completed with induction hardening, Hardness HRC 47 to 53.
【#】(シャープ)にはキー材とセットスクリューが付いております。【#】: Gear with key way and threaded hole / with key and screw.

許容伝達動力表 (W) 曲げ強さ

Allowable transfer capability table (W) Bending Strength

商品記号 Catalogue Numbers	回転速度 (min ⁻¹) revolution/min						
	300	600	900	1,200	1,500	1,800	2,000
M1.5S 20R - 2810	123.2	246.4	348.1	435.2	512.0	580.3	628.6
M1.5S 20R - 2810H	107.5	215.1	306.9	387.5	460.0	525.5	568.4

The above references are JGMA standard.

動力の換算式は P26 をご参照ください。Please refer to the conversion formulas of power on page P26.

許容伝達動力表 (W) 歯面強さ

Allowable transfer capability table (W) Surface Durability

商品記号 Catalogue Numbers	回転速度 (min ⁻¹) revolution/min						
	300	600	900	1,200	1,500	1,800	2,000
M1.5S 20R - 2810	16.7	33.9	48.4	61.1	72.8	83.6	91.3
M1.5S 20R - 2810H	45.5	93.8	136.2	174.2	208.8	240.5	261.4

目次
CONTENTS

インフォメーション
INFORMATION

ギヤボックス
GEAR BOXES

ノーバッキングスパイラルギヤ
ANTI BACKLASH SPIRAL GEARS

歯研平歯車
GROUND SPUR GEARS

平歯車
SPUR GEARS

内歯車
INTERNAL GEARS

歯研ラック
GROUND RACKS

ラック
RACKS

ヘリカルスクリューギヤ
HELICAL GEARS AND SCREW GEARS

ウォーム
WORMS AND WORM WHEELS

かなね歯車
BEVEL GEARS

スプロケット
SPROCKETS

技術資料
REFERENCE DATA

スパイラルミタギヤ

SPIRAL MITER GEARS

モジュール **1.5**
MODULE

圧力角 20° 歯数比 1:1 ねじれ角 35°
1:1 Ratio 20° PRESSURE ANGLE 35° SPIRAL ANGLE

JIS B1704 3級 (歯部高周波焼入品: 4級)
System of Accuracy: JIS B 1704 Class 3
(Induction hardened products: Class 4)



御注文には必ず“フルネームで商品記号”を明記してください。
Please refer to the catalogue reference while ordering.
 d_s の寸法は参考値です。
Dimension of d_s is for reference only.

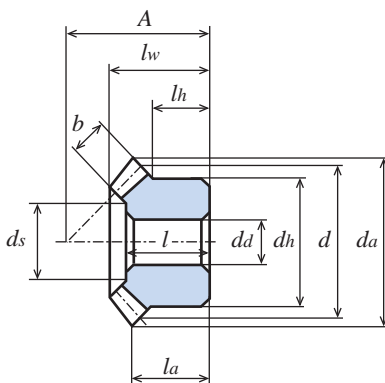

S45C 機械構造用炭素鋼 (JIS G 4051)

Material: Carbon Steel (ISO C45)

単位: mm
Dimensions: mm

商品記号 Catalogue Number	歯数比 Ratio	歯数 Number of Teeth	基準円直径 Reference Diameter	歯先円直径 Tip Diameter	組立距離 Locating Distance	穴径 Bore Diameter	ハブ外径 Hub Diameter	ハブ長さ Hub Projection	穴長さ Bore Length	全長 Overall Length	全長 Overall Length	歯幅 Face Width	キーみぞ Key Way	ねじ Set Screw		歯先角 Face Angle	d_s	重量 Weight
														2-M	l_s			
M1.5S 30R - 3812	1	30	$\phi 45$	$\phi 46.79$	38	$\phi 12$	$\phi 33$	12	21	22.64	16.4	9.3	-	-	-	47°54'	$\phi 29.7$	152.0
M1.5S 30L - 3812	1	30	$\phi 45$	$\phi 46.79$	38	$\phi 12$	$\phi 33$	12	21	22.64	16.4	9.3	-	-	-	47°54'	$\phi 29.7$	152.0
M1.5S 30R - 3812H	1	30	$\phi 45$	$\phi 46.79$	38	$\phi 12$ (H8)	$\phi 33$	12	21	22.64	16.4	9.3	-	-	-	47°54'	$\phi 29.7$	152.0
M1.5S 30L - 3812H	1	30	$\phi 45$	$\phi 46.79$	38	$\phi 12$ (H8)	$\phi 33$	12	21	22.64	16.4	9.3	-	-	-	47°54'	$\phi 29.7$	152.0
M1.5S 30R # 3815H	1	30	$\phi 45$	$\phi 46.79$	38	$\phi 15$ (H8)	$\phi 33$	12	21	22.64	16.4	9.3	5 × 2.3	2-M4	6	47°54'	$\phi 29.7$	140.8
M1.5S 30L # 3815H	1	30	$\phi 45$	$\phi 46.79$	38	$\phi 15$ (H8)	$\phi 33$	12	21	22.64	16.4	9.3	5 × 2.3	2-M4	6	47°54'	$\phi 29.7$	140.8

カタログ記号の末尾に【H】を付した商品は歯部高周波焼入済です。【H】: Gear tooth surface completed with induction hardening, Hardness HRC 47 to 53.
【#】(シャープ)にはキー材とセットスクリューが付いております。【#】: Gear with key way and threaded hole / with key and screw.

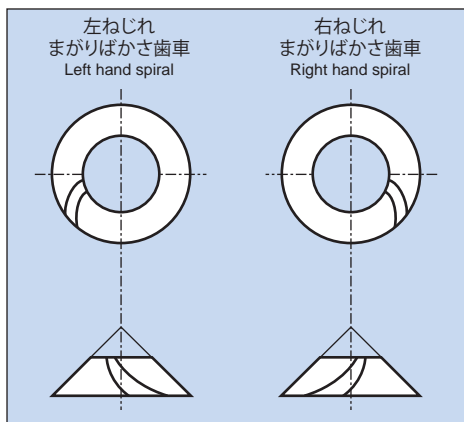

左まがり
Left hand spiral



右まがり
Right hand spiral

許容伝達動力表 (W) 曲げ強さ

Allowable transfer capability table (W) Bending Strength

商品記号 Catalogue Numbers	回転速度 (min ⁻¹) revolution/min						
	300	600	900	1,200	1,500	1,800	2,000
M1.5S 30R - 3812	286.5	539.5	735.8	899.5	1079.8	1262.1	1378.5
M1.5S 30R - 3812H	250.1	475.6	658.2	814.5	966.1	1108.9	1197.3

The above references are JGMA standard.

動力の換算式は P26 をご参照ください。Please refer to the conversion fomulas of power on page P26.

許容伝達動力表 (W) 歯面強さ

Allowable transfer capability table (W) Surface Durability

商品記号 Catalogue Numbers	回転速度 (min ⁻¹) revolution/min						
	300	600	900	1,200	1,500	1,800	2,000
M1.5S 30R - 3812	57.1	109.2	151.4	188.7	231.0	274.0	303.9
M1.5S 30R - 3812H	152.8	299.7	422.1	529.0	633.7	733.1	795.3

目次
CONTENTS
インフォメーション
INFORMATION
ギヤボックス
GEAR BOXES
ノーバッキングギヤ
ANTI BACKLASH SPIR GEARS
歯研平歯車
GROUND SPUR GEARS
平歯車
SPUR GEARS
内歯車
INTERNAL GEARS
歯研ラック
GROUND RACKS
ラック
RACKS
へリカル・スクリューギヤ
HELICAL GEARS AND SCREW GEARS
ワーム・ワームギヤ
WORMS AND WORM GEARS
かな歯車
BEVEL GEARS
スプロケット
SPROCKETS
技術資料
REFERENCE DATA

スパイラルベベルギヤ

SPIRAL BEVEL GEARS

モジュール **1.5**
MODULE

圧力角 20° 歯数比 1:2、1:3 ねじれ角 35°
1:2 and 1:3 Ratio 20° PRESSURE ANGLE 35° SPIRAL ANGLE

JIS B1704 3級 (歯部高周波焼入品:4級)
System of Accuracy: JIS B 1704 Class 3
(Induction hardened products: Class 4)



New 仕様変更 締結加工不要。
Additional machining on tightening is not necessary.

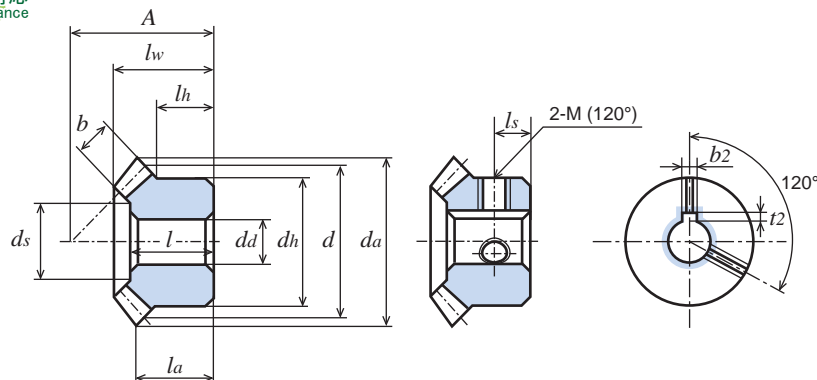

S45C 機械構造用炭素鋼 (JIS G 4051)

Material: Carbon Steel (ISO C45)

単位: mm
Dimensions: mm

商品記号 Catalogue Number	歯数比 Ratio	歯数 Number of Teeth	基準円直径 Reference Diameter	歯先円直径 Tip Diameter	組立距離 Locating Distance	穴径 Bore Diameter	ハブ外径 Hub Diameter	ハブ長さ Hub Projection	穴長さ Bore Length	全長 Overall Length	歯幅 Face Width	ねじ Set Screw	歯先角 Face Angle	重量 Weight	
															キーみぞ Key Way
B1.5S 18L - 8	2	18	φ27	φ30.09	40.74	φ8	φ22	12.49	21	22.96	14.51	-	30°44'	φ12.2	59.6
B1.5S 18L - 8H	2	18	φ27	φ30.09	40.74	φ8 (H8)	φ22	12.49	21	22.96	14.51	-	30°44'	φ12.2	59.6
B1.5S 18L # 10H	2	18	φ27	φ30.09	40.74	φ10 (H8)	φ22	12.49	21	22.96	14.51	3 × 1.4	2-M4	6.5	54.2
B1.5S 36R - 10	2	36	φ54	φ54.76	26.75	φ10	φ30	9	15.5	18.01	14.01	-	65°57'	φ34.3	143.0
B1.5S 36R - 10H	2	36	φ54	φ54.76	26.75	φ10 (H8)	φ30	9	15.5	18.01	14.01	-	65°57'	φ34.3	143.0
B1.5S 36R # 15H	2	36	φ54	φ54.76	26.75	φ15 (H8)	φ30	9	15.5	18.01	14.01	5 × 2.3	2-M4	4.5	130.6
B1.5S 15L - 8	3	15	φ22.5	φ25.99	46	φ8	φ19.5	11.75	21.1	22.19	12.83	-	22°28'	φ11.7	41.9
B1.5S 15L - 8H	3	15	φ22.5	φ25.99	46	φ8 (H8)	φ19.5	11.75	21.1	22.19	12.83	-	22°28'	φ11.7	41.9
B1.5S 45R - 12	3	45	φ67.5	φ68.01	30	φ12	φ37.5	12	19.4	22.31	19.51	-	73°56'	φ46.6	283.0
B1.5S 45R - 12H	3	45	φ67.5	φ68.01	30	φ12 (H8)	φ37.5	12	19.4	22.31	19.51	-	73°56'	φ46.6	283.0

カタログ記号の末尾に【H】を付した商品は歯部高周波焼入済です。【H】: Gear tooth surface completed with induction hardening, Hardness HRC 47 to 53.
【#】(シャープ)にはキー材とセットスクリューが付いております。【#】: Gear with key way and threaded hole / with key and screw.

	歯数比 Ratio	ピッチ角 Pitch Angle		軸角 Shaft Angle
マイタギヤ Miter gear	1:1	45°		90°
ベベルギヤ Bevel gear	1:2	ピニオン ギヤ Pinion Gear	26° 34' 63° 26'	90°
	1:3	ピニオン ギヤ Pinion Gear	18° 26' 71° 34'	90°

許容伝達動力表 (W) 曲げ強さ

Allowable transfer capability table (W) Bending Strength

商品記号 Catalogue Numbers	回転速度 (min ⁻¹) revolution/min						
	300	600	900	1,200	1,500	1,800	2,000
B1.5S 18L - 8	149.1	298.3	430.0	540.3	638.6	726.7	780.6
B1.5S 18L - 8H	130.2	260.4	377.8	479.2	571.2	654.9	706.8
B1.5S 15L - 8	126.2	252.5	375.3	475.5	566.1	648.5	699.4
B1.5S 15L - 8H	110.2	220.4	328.2	419.2	502.9	580.1	628.3

The above references are JGMA standard.

動力の換算式は P26 をご参照ください。Please refer to the conversion formulas of power on page P26.

許容伝達動力表 (W) 歯面強さ

Allowable transfer capability table (W) Surface Durability

商品記号 Catalogue Numbers	回転速度 (min ⁻¹) revolution/min						
	300	600	900	1,200	1,500	1,800	2,000
B1.5S 18L - 8	23.5	47.4	69.0	87.5	104.5	120.3	130.2
B1.5S 18L - 8H	63.9	131.8	194.6	232.5	300.9	347.8	377.1
B1.5S 15L - 8	17.8	36.0	53.9	68.9	82.6	95.5	103.6
B1.5S 15L - 8H	48.7	100.5	152.4	197.1	238.5	277.7	302.2

スパイラルミタギヤ

SPIRAL MITER GEARS

モジュール **2**
MODULE

圧力角 20° 歯数比 1:1 ねじれ角 35°
1:1 Ratio 20° PRESSURE ANGLE 35° SPIRAL ANGLE

JIS B1704 3級 (歯部高周波焼入品: 4級)
System of Accuracy: JIS B 1704 Class 3
(Induction hardened products: Class 4)



御注文には必ず“フルネームで商品記号”を明記してください。
Please refer to the catalogue reference while ordering.
 d_s の寸法は参考値です。
Dimension of d_s is for reference only.

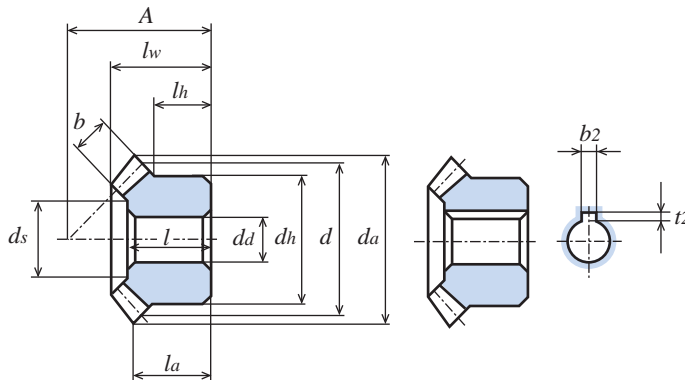

S45C 機械構造用炭素鋼 (JIS G 4051)

Material: Carbon Steel (ISO C45)

単位: mm
Dimensions: mm

商品記号 Catalogue Number	歯数比 Ratio u	歯数 Number of Teeth z	基準円直径 Reference Diameter d	歯先円直径 Tip Diameter d_a	組立距離 Locating Distance A	穴径 Bore Diameter $d_a(H7)$	ハブ外径 Hub Diameter d_h	ハブ長さ Hub Projection l_h	穴長さ Bore Length l	全長 Overall Length l_w	全長 Overall Length l_w	歯幅 Face Width b	キミぞ Key Way $b_2 \times t_2$	ねじ Set Screw		歯先角 Face Angle δ_a	ねじれ角 Spiral Angle d_s	重量 Weight $W(g)$
														2-M	ls			
M2S 20R - 3712	1	20	$\phi 40$	$\phi 40.8$ <small>($\phi 42.28$)</small>	37	$\phi 12$	$\phi 34$	14	21	24.16	18.14	9	-	-	-	48° 3'	$\phi 22.5$	141.0
M2S 20L - 3712	1	20	$\phi 40$	$\phi 40.8$ <small>($\phi 42.28$)</small>	37	$\phi 12$	$\phi 34$	14	21	24.16	18.14	9	-	-	-	48° 3'	$\phi 22.5$	141.0
M2S 20R - 3712H	1	20	$\phi 40$	$\phi 40.8$ <small>($\phi 42.28$)</small>	37	$\phi 12(H8)$	$\phi 34$	14	21	24.16	18.14	9	-	-	-	48° 3'	$\phi 22.5$	141.0
M2S 20L - 3712H	1	20	$\phi 40$	$\phi 40.8$ <small>($\phi 42.28$)</small>	37	$\phi 12(H8)$	$\phi 34$	14	21	24.16	18.14	9	-	-	-	48° 3'	$\phi 22.5$	141.0
M2S 20R # 3715H	1	20	$\phi 40$	$\phi 40.8$ <small>($\phi 42.28$)</small>	37	$\phi 15(H8)$	$\phi 34$	14	21	24.16	18.14	9	5 × 2.3	2-M5	7	48° 3'	$\phi 22.5$	127.5
M2S 20L # 3715H	1	20	$\phi 40$	$\phi 40.8$ <small>($\phi 42.28$)</small>	37	$\phi 15(H8)$	$\phi 34$	14	21	24.16	18.14	9	5 × 2.3	2-M5	7	48° 3'	$\phi 22.5$	127.5
M2S 20R # 3716H	1	20	$\phi 40$	$\phi 40.8$ <small>($\phi 42.28$)</small>	37	$\phi 16(H8)$	$\phi 34$	14	21	24.16	18.14	9	5 × 2.3	2-M5	7	48° 3'	$\phi 22.5$	123.5
M2S 20L # 3716H	1	20	$\phi 40$	$\phi 40.8$ <small>($\phi 42.28$)</small>	37	$\phi 16(H8)$	$\phi 34$	14	21	24.16	18.14	9	5 × 2.3	2-M5	7	48° 3'	$\phi 22.5$	123.5
M2S 20R - 2812	1	20	$\phi 40$	$\phi 40.8$ <small>($\phi 42.28$)</small>	28	$\phi 12$	$\phi 34$	5	12	15.16	9.14	9	-	-	-	48° 3'	$\phi 22.5$	84.9
M2S 20L - 2812	1	20	$\phi 40$	$\phi 40.8$ <small>($\phi 42.28$)</small>	28	$\phi 12$	$\phi 34$	5	12	15.16	9.14	9	-	-	-	48° 3'	$\phi 22.5$	84.9
M2S 20R - 2812H	1	20	$\phi 40$	$\phi 40.8$ <small>($\phi 42.28$)</small>	28	$\phi 12(H8)$	$\phi 34$	5	12	15.16	9.14	9	-	-	-	48° 3'	$\phi 22.5$	84.9
M2S 20L - 2812H	1	20	$\phi 40$	$\phi 40.8$ <small>($\phi 42.28$)</small>	28	$\phi 12(H8)$	$\phi 34$	5	12	15.16	9.14	9	-	-	-	48° 3'	$\phi 22.5$	84.9
M2S 20R = 2815H	1	20	$\phi 40$	$\phi 40.8$ <small>($\phi 42.28$)</small>	28	$\phi 15(H8)$	$\phi 34$	5	12	15.16	9.14	9	5 × 2.3	-	-	48° 3'	$\phi 22.5$	77.8
M2S 20L = 2815H	1	20	$\phi 40$	$\phi 40.8$ <small>($\phi 42.28$)</small>	28	$\phi 15(H8)$	$\phi 34$	5	12	15.16	9.14	9	5 × 2.3	-	-	48° 3'	$\phi 22.5$	77.8

カタログ記号の末尾に【H】を付した商品は歯部高周波焼入済です。【H】: Gear tooth surface completed with induction hardening, Hardness HRC 47 to 53.
【#】(シャープ)にはキー材とセットスクリューが付いております。【#】: Gear with key way and threaded hole / with key and screw.

許容伝達動力表 (kW) 曲げ強さ

Allowable transfer capability table (kW) Bending Strength

商品記号 Catalogue Numbers	回転速度 (min ⁻¹) revolution/min						
	300	600	900	1,200	1,500	1,800	2,000
M2S 20R - 3712	0.296	0.555	0.764	0.941	1.104	1.293	1.415
M2S 20R - 3712H	0.251	0.488	0.680	0.847	0.998	1.150	1.245

The above references are JGMA standard.

動力の換算式は P26 をご参照ください。Please refer to the conversion formulas of power on page P26.

許容伝達動力表 (kW) 歯面強さ

Allowable transfer capability table (kW) Surface Durability

商品記号 Catalogue Numbers	回転速度 (min ⁻¹) revolution/min						
	300	600	900	1,200	1,500	1,800	2,000
M2S 20R - 3712	0.040	0.078	0.109	0.137	0.163	0.195	0.215
M2S 20R - 3712H	0.108	0.216	0.307	0.387	0.460	0.535	0.581

- 目次 CONTENTS
- インフォメーション INFORMATION
- ギヤボックス GEAR BOXES
- ノーバッキングミタギヤ ANTI BACKLASH SPIRAL MITER GEARS
- 歯研歯車 GROUND SPUR GEARS
- 平歯車 SPUR GEARS
- 内歯車 INTERNAL GEARS
- 歯研ラック GROUND RACKS
- ラック RACKS
- へリカル・スクリューギヤ HELICAL GEARS AND SCREW GEARS
- ワーム・ワームホイール WORMS AND WORM WHEELS
- かなめ歯車 BEVEL GEARS
- スプロケット SPROCKETS
- 技術資料 REFERENCE DATA

スパイラルミタギヤ

SPIRAL MITER GEARS

モジュール **2**
MODULE

圧力角 20° 歯数比 1:1 ねじれ角 35°
1:1 Ratio 20° PRESSURE ANGLE 35° SPIRAL ANGLE

JIS B1704 3級 (歯部高周波焼入品: 4級)
System of Accuracy: JIS B 1704 Class 3
(Induction hardened products: Class 4)



仕様変更 締結加工不要。
Additional machining on tightening is not necessary.

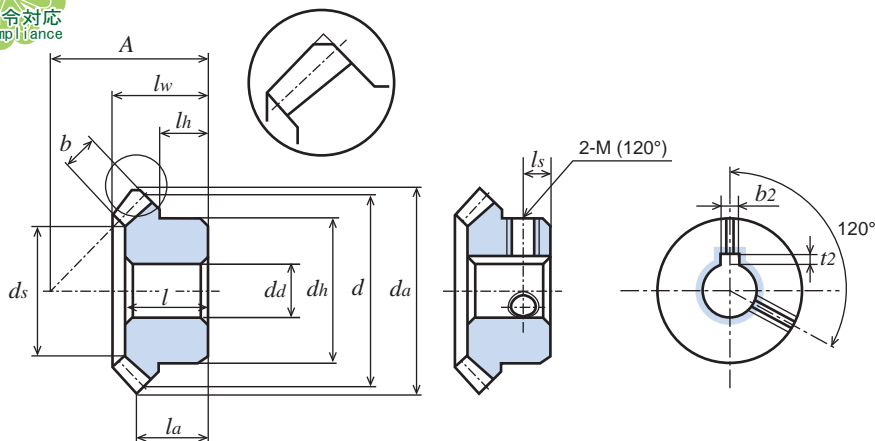

S45C 機械構造用炭素鋼 (JIS G 4051)

Material: Carbon Steel (ISO C45)

単位: mm
Dimensions: mm

商品記号 Catalogue Number	歯数比 Ratio	歯数 Number of Teeth	基準円直径 Reference Diameter	歯先円直径 Tip Diameter	組立距離 Locating Distance	穴径 Bore Diameter	ハブ外径 Hub Diameter	ハブ長さ Hub Projection	穴長さ Bore Length	全長 Overall Length	全長 Tip Distance	歯幅 Face Width	キーみぞ Key Way	ねじ Set Screw		歯先角 Face Angle	歯先角 Face Angle	重量 Weight
														2-M	ls			
M2S 30R - 5116	1	30	$\phi 60$	$\phi 60.94^{(\phi 62.42)}$	51	$\phi 16$	$\phi 44$	17	28	30.53	22.21	12.4	-	-	-	47°54'	$\phi 38.9$	358.4
M2S 30L - 5116	1	30	$\phi 60$	$\phi 60.94^{(\phi 62.42)}$	51	$\phi 16$	$\phi 44$	17	28	30.53	22.21	12.4	-	-	-	47°54'	$\phi 38.9$	358.4
M2S 30R - 5116H	1	30	$\phi 60$	$\phi 60.94^{(\phi 62.42)}$	51	$\phi 16(H8)$	$\phi 44$	17	28	30.53	22.21	12.4	-	-	-	47°54'	$\phi 38.9$	358.4
M2S 30L - 5116H	1	30	$\phi 60$	$\phi 60.94^{(\phi 62.42)}$	51	$\phi 16(H8)$	$\phi 44$	17	28	30.53	22.21	12.4	-	-	-	47°54'	$\phi 38.9$	358.4
M2S 30R # 5120H	1	30	$\phi 60$	$\phi 60.94^{(\phi 62.42)}$	51	$\phi 20(H8)$	$\phi 44$	17	28	30.53	22.21	12.4	6 × 2.8	2-M5	8.5	47°54'	$\phi 38.9$	331.9
M2S 30L # 5120H	1	30	$\phi 60$	$\phi 60.94^{(\phi 62.42)}$	51	$\phi 20(H8)$	$\phi 44$	17	28	30.53	22.21	12.4	6 × 2.8	2-M5	8.5	47°54'	$\phi 38.9$	331.9

カタログ記号の末尾に【H】を付した商品は歯部高周波焼入済です。【H】: Gear tooth surface completed with induction hardening, Hardness HRC 47 to 53.
【#】(シャープ)にはキー材とセットスクリーが付いております。【#】: Gear with key way and threaded hole / with key and screw.

歯先円直径 da の () 内は理論値です。最大外径は軸心と平行に面取りしてありますので、理論値より小さくなっています。

The numeric indicated in the bracket () under the column. Outside diameter da has been machined flat. With this process, the outer diameter is smaller than the theory with respect to shaft center to parallel.

許容伝達動力表 (kW) 曲げ強さ

Allowable transfer capability table (kW) Bending Strength

商品記号 Catalogue Numbers	回転速度 (min ⁻¹) revolution/min						
	300	600	900	1,200	1,500	1,800	2,000
M2S 30R - 5116	0.682	1.205	1.607	2.040	2.463	2.880	3.154
M2S 30R - 5116H	0.596	1.073	1.455	1.814	2.139	-	-

The above references are JGMA standard.

動力の換算式は P26 をご参照ください。Please refer to the conversion formulas of power on page P26.

許容伝達動力表 (kW) 歯面強さ

Allowable transfer capability table (kW) Surface Durability

商品記号 Catalogue Numbers	回転速度 (min ⁻¹) revolution/min						
	300	600	900	1,200	1,500	1,800	2,000
M2S 30R - 5116	0.140	0.253	0.346	0.450	0.557	0.669	0.744
M2S 30R - 5116H	0.371	0.690	0.952	1.202	1.432	-	-

JIS B1704 3級 (歯部高周波焼入品:4級)
System of Accuracy: JIS B 1704 Class 3
(Induction hardened products: Class 4)



御注文には必ず“フルネームで商品記号”を明記してください。
Please refer to the catalogue reference while ordering.
 d_s の寸法は参考値です。
Dimension of d_s is for reference only.

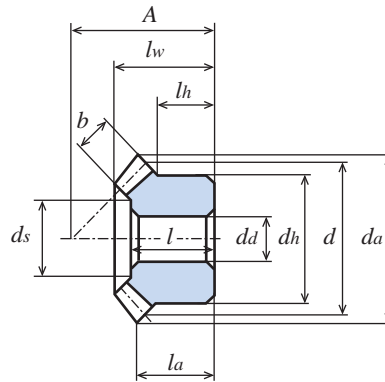

S45C 機械構造用炭素鋼 (JIS G 4051)

Material: Carbon Steel (ISO C45)

単位: mm
Dimensions: mm

商品記号 Catalogue Number	歯数比 Ratio	歯数 Number of Teeth	基準円直径 Reference Diameter	歯先円直径 Tip Diameter	組立距離 Locating Distance	穴径 Bore Diameter	ハブ外径 Hub Diameter	ハブ長さ Hub Projection	穴長さ Bore Length	全長 Overall Length	歯幅 Face Width	ねじ Set Screw	歯先角 Face Angle	重量 Weight			
															u	z	d
B2S 18L - 10	2	18	$\phi 36$	$\phi 38.35$ <small>($\phi 40.20$)</small>	53.12	$\phi 10$	$\phi 28$	15.12	27	29.36	18.17	-	30°53'	130.3			
B2S 18L - 10H	2	18	$\phi 36$	$\phi 38.35$ <small>($\phi 40.20$)</small>	53.12	$\phi 10(H8)$	$\phi 28$	15.12	27	29.36	18.17	-	30°53'	130.3			
B2S 18L # 12H	2	18	$\phi 36$	$\phi 38.35$ <small>($\phi 40.20$)</small>	53.12	$\phi 12(H8)$	$\phi 28$	15.12	27	29.36	18.17	4 × 1.8	2-M5	7.5	30°53'	$\phi 17.4$	122.0
B2S 36R - 12	2	36	$\phi 72$	$\phi 71.41$ <small>($\phi 73.05$)</small>	35.21	$\phi 12$	$\phi 36$	12	21	23.54	18.26	-	66° 6'	318.4			
B2S 36R - 12H	2	36	$\phi 72$	$\phi 71.41$ <small>($\phi 73.05$)</small>	35.21	$\phi 12(H8)$	$\phi 36$	12	21	23.54	18.26	-	66° 6'	318.4			
B2S 36R # 20H	2	36	$\phi 72$	$\phi 71.41$ <small>($\phi 73.05$)</small>	35.21	$\phi 20(H8)$	$\phi 36$	12	21	23.54	18.26	6 × 2.8	2-M5	6	66° 6'	$\phi 46.7$	284.0
B2S 15L - 10	3	15	$\phi 30$	$\phi 33.35$ <small>($\phi 34.66$)</small>	62	$\phi 10$	$\phi 26$	16.33	28.9	30.2	17.78	-	22°19'	104.0			
B2S 15L - 10H	3	15	$\phi 30$	$\phi 33.35$ <small>($\phi 34.66$)</small>	62	$\phi 10(H8)$	$\phi 26$	16.33	28.9	30.2	17.78	-	22°19'	104.0			
B2S 45R - 14	3	45	$\phi 90$	$\phi 89.16$ <small>($\phi 90.68$)</small>	40	$\phi 14$	$\phi 50$	16	25.9	29.76	26.02	-	73°47'	680.6			
B2S 45R - 14H	3	45	$\phi 90$	$\phi 89.16$ <small>($\phi 90.68$)</small>	40	$\phi 14(H8)$	$\phi 50$	16	25.9	29.76	26.02	-	73°47'	680.6			

カタログ記号の末尾に【H】を付した商品は歯部高周波焼入済です。【H】: Gear tooth surface completed with induction hardening, Hardness HRC 47 to 53.
【#】(シャープ)にはキー材とセットスクリューが付いております。【#】: Gear with key way and threaded hole / with key and screw.

許容伝達動力表 (kW) 曲げ強さ

Allowable transfer capability table (kW) Bending Strength

商品記号 Catalogue Numbers	回転速度 (min ⁻¹) revolution/min						
	300	600	900	1,200	1,500	1,800	2,000
B2S 18L - 10	0.355	0.697	0.966	1.196	1.396	1.617	1.771
B2S 18L - 10H	0.310	0.611	0.857	1.073	1.264	1.452	1.575
B2S 15L - 10	0.304	0.608	0.859	1.074	1.264	1.433	1.552
B2S 15L - 10H	0.265	0.531	0.757	0.956	1.135	1.297	1.403

The above references are JGMA standard.

動力の換算式は P26 をご参照ください。Please refer to the conversion formulas of power on page P26.

許容伝達動力表 (kW) 歯面強さ

Allowable transfer capability table (kW) Surface Durability

商品記号 Catalogue Numbers	回転速度 (min ⁻¹) revolution/min						
	300	600	900	1,200	1,500	1,800	2,000
B2S 18L - 10	0.057	0.114	0.160	0.200	0.238	0.280	0.309
B2S 18L - 10H	0.155	0.314	0.448	0.569	0.677	0.784	0.854
B2S 15L - 10	0.043	0.088	0.125	0.159	0.189	0.217	0.237
B2S 15L - 10H	0.118	0.243	0.353	0.452	0.542	0.624	0.679

スパイラルミタギヤ

SPIRAL MITER GEARS

モジュール **2.5**
MODULE

圧力角 20° 歯数比 1:1 ねじれ角 35°
1:1 Ratio 20° PRESSURE ANGLE 35° SPIRAL ANGLE

JIS B1704 3級 (歯部高周波焼入品: 4級)
System of Accuracy: JIS B 1704 Class 3
(Induction hardened products: Class 4)



仕様変更 締結加工不要。
Additional machining on tightening is not necessary.

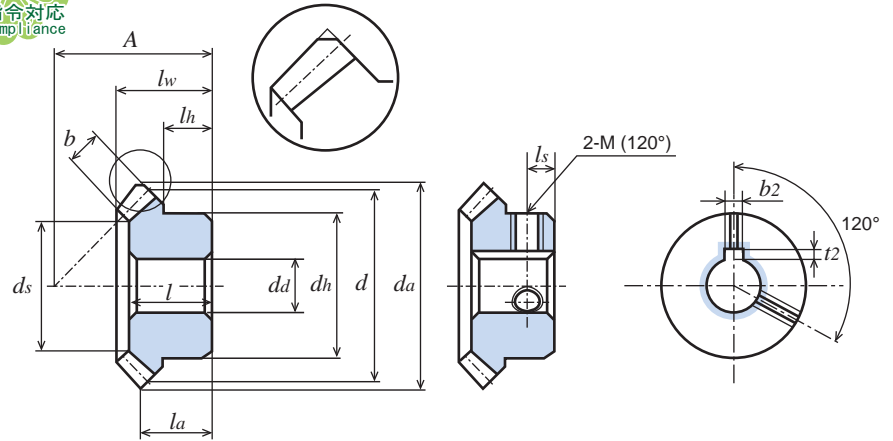

S45C 機械構造用炭素鋼 (JIS G 4051)
Material: Carbon Steel (ISO C45)

単位: mm
Dimensions: mm

商品記号 Catalogue Number	歯数比 Ratio u	歯数 Number of Teeth z	基準円直径 Reference Diameter d	歯先円直径 Tip Diameter da	組立距離 Locating Distance A	穴径 Bore Diameter da(H7)	ハブ外径 Hub Diameter dh	ハブ長さ Hub Projection lh	穴長さ Bore Length l	全長 Overall Length lw	全長 Overall Length la	歯幅 Face Width b	キミぞ Key Way b2 × t2	ねじ Set Screw		歯先角 Face Angle δa	ねじれ角 Spiral Angle ds	重量 Weight W(g)
														2-M	ls			
M2.5S 20R - 4814	1	20	φ50	φ51.14 ^(φ53.02)	48	φ14	φ42	19	28	31.77	24.51	11.1	-	-	-	49°20'	φ28.6	292.4
M2.5S 20L - 4814	1	20	φ50	φ51.14 ^(φ53.02)	48	φ14	φ42	19	28	31.77	24.51	11.1	-	-	-	49°20'	φ28.6	292.4
M2.5S 20R - 4814H	1	20	φ50	φ51.14 ^(φ53.02)	48	φ14(H8)	φ42	19	28	31.77	24.51	11.1	-	-	-	49°20'	φ28.6	292.4
M2.5S 20L - 4814H	1	20	φ50	φ51.14 ^(φ53.02)	48	φ14(H8)	φ42	19	28	31.77	24.51	11.1	-	-	-	49°20'	φ28.6	292.4
M2.5S 20R # 4820H	1	20	φ50	φ51.14 ^(φ53.02)	48	φ20(H8)	φ42	19	28	31.77	24.51	11.1	6 × 2.8	2-M5	9.5	49°20'	φ28.6	255.8
M2.5S 20L # 4820H	1	20	φ50	φ51.14 ^(φ53.02)	48	φ20(H8)	φ42	19	28	31.77	24.51	11.1	6 × 2.8	2-M5	9.5	49°20'	φ28.6	255.8
M2.5S 30R - 6318	1	30	φ75	φ76.2 ^(φ78.05)	63	φ18	φ55	20	34.5	37.07	27.03	15	-	-	-	48° 3'	φ50.6	708.7
M2.5S 30L - 6318	1	30	φ75	φ76.2 ^(φ78.05)	63	φ18	φ55	20	34.5	37.07	27.03	15	-	-	-	48° 3'	φ50.6	708.7
M2.5S 30R - 6318H	1	30	φ75	φ76.2 ^(φ78.05)	63	φ18(H8)	φ55	20	34.5	37.07	27.03	15	-	-	-	48° 3'	φ50.6	708.7
M2.5S 30L - 6318H	1	30	φ75	φ76.2 ^(φ78.05)	63	φ18(H8)	φ55	20	34.5	37.07	27.03	15	-	-	-	48° 3'	φ50.6	708.7
M2.5S 30R # 6325H	1	30	φ75	φ76.2 ^(φ78.05)	63	φ25(H8)	φ55	20	34.5	37.07	27.03	15	8 × 3.3	2-M6	10	48° 3'	φ50.6	641.9
M2.5S 30L # 6325H	1	30	φ75	φ76.2 ^(φ78.05)	63	φ25(H8)	φ55	20	34.5	37.07	27.03	15	8 × 3.3	2-M6	10	48° 3'	φ50.6	641.9

カタログ記号の末尾に【H】を付した商品は歯部高周波焼入済です。【H】: Gear tooth surface completed with induction hardening, Hardness HRC 47 to 53.
【#】(シャープ)にはキー材とセットスクリューが付いております。【#】: Gear with key way and threaded hole / with key and screw.

許容伝達動力表 (kW) 曲げ強さ

Allowable transfer capability table (kW) Bending Strength

商品記号 Catalogue Numbers	回転速度 (min ⁻¹) revolution/min						
	300	600	900	1,200	1,500	1,800	2,000
M2.5S 20R - 4814	0.562	1.036	1.402	1.721	2.089	2.435	2.663
M2.5S 20R - 4814H	0.491	0.916	1.259	1.556	1.850	2.115	-
M2.5S 30R - 6318	1.274	2.174	2.959	3.777	4.576	5.345	5.835
M2.5S 30R - 6318H	1.117	1.953	2.647	3.281	-	-	-

The above references are JGMA standard.

動力の換算式は P26 をご参照ください。Please refer to the conversion formulas of power on page P26.

許容伝達動力表 (kW) 歯面強さ

Allowable transfer capability table (kW) Surface Durability

商品記号 Catalogue Numbers	回転速度 (min ⁻¹) revolution/min						
	300	600	900	1,200	1,500	1,800	2,000
M2.5S 20R - 4814	0.080	0.150	0.207	0.260	0.322	0.383	0.425
M2.5S 20R - 4814H	0.214	0.411	0.576	0.721	0.865	0.997	-
M2.5S 30R - 6318	0.269	0.472	0.663	0.873	1.093	1.311	1.454
M2.5S 30R - 6318H	0.709	1.278	1.763	2.213	-	-	-

スパイラルベベルギヤ SPIRAL BEVEL GEARS

モジュール **2.5**
MODULE

圧力角 20° 歯数比 1:2, 1:3 ねじれ角 35°
1:2 and 1:2 Ratio 20° PRESSURE ANGLE 35° SPIRAL ANGLE

JIS B1704 3級 (歯部高周波焼入品:4級)
System of Accuracy: JIS B 1704 Class 3
(Induction hardened products: Class 4)



御注文には必ず“フルネームで商品記号”を明記してください。
Please refer to the catalogue reference while ordering.
 d_s の寸法は参考値です。
Dimension of d_s is for reference only.

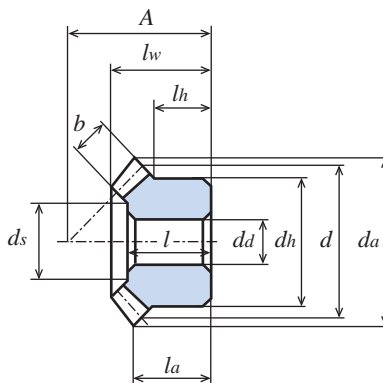

S45C 機械構造用炭素鋼 (JIS G 4051) Material: Carbon Steel (ISO C45)

単位: mm
Dimensions: mm

商品記号 Catalogue Number	歯数比 Ratio u	歯数 Number of Teeth z	基準円直径 Reference Diameter d	歯先円直径 Tip Diameter d_a	組立距離 Locating Distance A	穴径 Bore Diameter $d_i(H7)$	ハブ外径 Hub Diameter d_h	ハブ長さ Hub Projection l_h	穴長さ Bore Length l	全長 Overall Length l_w	Tip Distance l_a	歯幅 Face Width b	キヤミぞ Key Way $b_2 \times t_2$	ねじ Set Screw		歯先角 Face Angle δ_a	d_s	重量 Weight $W(kg)$
														2-M	ls			
B2.5S 18L - 12	2	18	$\phi 45$	$\phi^{(\phi 50.25)}$ $\phi 48.63$	64.29	$\phi 12$	$\phi 36$	17.04	32	34.98	20.6	16.7	-	-	-	30°53'	$\phi 21.2$	0.25
B2.5S 18L - 12H	2	18	$\phi 45$	$\phi^{(\phi 50.25)}$ $\phi 48.63$	64.29	$\phi 12(H8)$	$\phi 36$	17.04	32	34.98	20.6	16.7	-	-	-	30°53'	$\phi 21.2$	0.25
B2.5S 18L # 15H	2	18	$\phi 45$	$\phi^{(\phi 50.25)}$ $\phi 48.63$	64.29	$\phi 15(H8)$	$\phi 36$	17.04	32	34.98	20.6	16.7	5 × 2.3	2-M5	8.5	30°53'	$\phi 21.2$	0.24
B2.5S 36R - 14	2	36	$\phi 90$	$\phi^{(\phi 91.32)}$ $\phi 89.88$	42.55	$\phi 14$	$\phi 50$	14	25	28.14	21.37	16.7	-	-	-	66° 6'	$\phi 57.6$	0.64
B2.5S 36R - 14H	2	36	$\phi 90$	$\phi^{(\phi 91.32)}$ $\phi 89.88$	42.55	$\phi 14(H8)$	$\phi 50$	14	25	28.14	21.37	16.7	-	-	-	66° 6'	$\phi 57.6$	0.64
B2.5S 36R # 25H	2	36	$\phi 90$	$\phi^{(\phi 91.32)}$ $\phi 89.88$	42.55	$\phi 25(H8)$	$\phi 50$	14	25	28.14	21.37	16.7	8 × 3.3	2-M6	7	66° 6'	$\phi 57.6$	0.58
B2.5S 15L - 10	3	15	$\phi 37.5$	$\phi^{(\phi 43.13)}$ $\phi 41.90$	77.93	$\phi 10(H8)$	$\phi 32$	20.76	36.5	38.45	22.62	17	-	-	-	21°36'	$\phi 18.9$	0.21
B2.5S 15L - 10H	3	15	$\phi 37.5$	$\phi^{(\phi 43.13)}$ $\phi 41.90$	77.93	$\phi 10(H8)$	$\phi 32$	20.76	36.5	38.45	22.62	17	-	-	-	21°36'	$\phi 18.9$	0.21
B2.5S 45R - 16	3	45	$\phi 112.5$	$\phi^{(\phi 113.28)}$ $\phi 112.2$	40.67	$\phi 16$	$\phi 60$	14	24.5	28.05	23.09	17	-	-	-	73° 3'	$\phi 78.3$	1.01
B2.5S 45R - 16H	3	45	$\phi 112.5$	$\phi^{(\phi 113.28)}$ $\phi 112.2$	40.67	$\phi 16(H8)$	$\phi 60$	14	24.5	28.05	23.09	17	-	-	-	73° 3'	$\phi 78.3$	1.01

カタログ記号の末尾に【H】を付した商品は歯部高周波焼入済です。【H】: Gear tooth surface completed with induction hardening, Hardness HRC 47 to 53.
【#】(シャープ)にはキヤ材とセットスクリューが付いております。【#】: Gear with key way and threaded hole / with key and screw.

歯先円直径 d_a の () 内は理論値です。最大外径は軸心と平行に面取りしてありますので、理論値より小さくなっています。

The numeric indicated in the bracket () under the column. Outside diameter d_a has been machined flat. With this process, the outer diameter is smaller than the theory with respect to shaft center to parallel.

許容伝達動力表 (kW) 曲げ強さ

Allowable transfer capability table (kW) Bending Strength

商品記号 Catalogue Numbers	回転速度 (min ⁻¹) revolution/min						
	300	600	900	1,200	1,500	1,800	2,000
B2.5S 18L - 12	0.710	1.337	1.824	2.230	2.677	3.129	3.417
B2.5S 18L - 12H	0.620	1.179	1.631	2.019	2.395	2.749	2.968
B2.5S 15L - 10	0.607	1.183	1.634	2.019	2.351	2.748	3.008
B2.5S 15L - 10H	0.530	1.037	1.452	1.814	2.133	2.458	2.664

The above references are JGMA standard.

動力の換算式は P26 をご参照ください。Please refer to the conversion formulas of power on page P26.

許容伝達動力表 (kW) 歯面強さ

Allowable transfer capability table (kW) Surface Durability

商品記号 Catalogue Numbers	回転速度 (min ⁻¹) revolution/min						
	300	600	900	1,200	1,500	1,800	2,000
B2.5S 18L - 12	0.117	0.224	0.310	0.387	0.473	0.561	0.623
B2.5S 18L - 12H	0.314	0.615	0.867	1.086	1.301	1.505	1.633
B2.5S 15L - 10	0.088	0.174	0.244	0.306	0.362	0.430	0.475
B2.5S 15L - 10H	0.237	0.479	0.683	0.864	1.027	1.193	1.298

目次
CONTENTS
インフォメーション
INFORMATION
ギヤボックス
GEAR BOXES
ノーバッキングスピリギヤ
ANTI BACKLASH SPIR GEAR
歯研削歯車
GROUND SPUR GEARS
平歯車
SPUR GEARS
内歯車
INTERNAL GEARS
歯研削ギヤ
GROUND RACKS
ラック
RACKS
へリカル・スクリューギヤ
HELICAL GEARS AND SCREW GEARS
ワーム
WORMS
ワームギヤ
WORMS AND WORM GEARS
かな歯車
BEVEL GEARS
スプロケット
SPROCKETS
技術資料
REFERENCE DATA

スパイラルマイタギヤ SPIRAL MITER GEARS

モジュール 3
MODULE 3

圧力角 20° 歯数比 1:1 ねじれ角 35°
1:1 Ratio 20° PRESSURE ANGLE 35° SPIRAL ANGLE

JIS B1704 3級 (歯部高周波焼入品:4級)
System of Accuracy: JIS B 1704 Class 3
(Induction hardened products: Class 4)



仕様変更 締結加工不要。
Additional machining on tightening is not necessary.

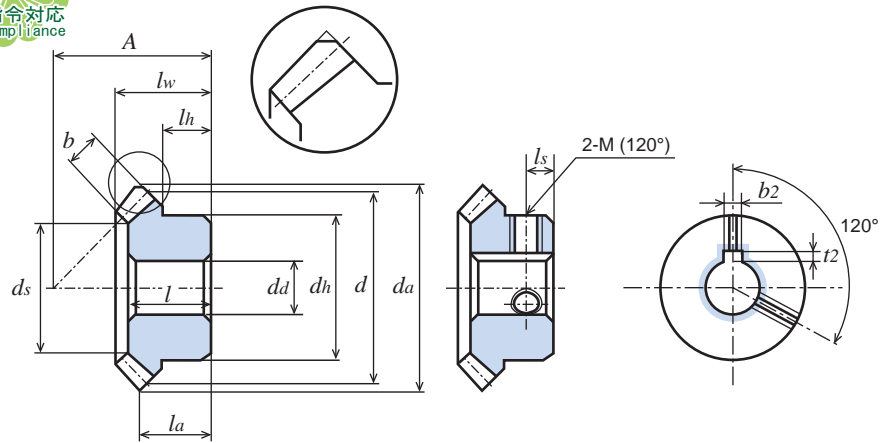

S45C 機械構造用炭素鋼 (JIS G 4051)
Material: Carbon Steel (ISO C45)

単位: mm
Dimensions: mm

商品記号 Catalogue Number	歯数比 Ratio	歯数 Number of Teeth	基準円直径 Reference Diameter	歯先円直径 Tip Diameter	組立距離 Locating Distance	穴径 Bore Diameter	ハブ外径 Hub Diameter	ハブ長さ Hub Projection	穴長さ Bore Length	全長 Overall Length	Tip Distance	歯幅 Face Width	キミぞ Key Way	ねじ Set Screw		歯先角 Face Angle	歯先角 Face Angle	重量 Weight
														2-M	ls			
M3S 20R - 5816	1	20	$\phi 60$	$\phi 61.39$ ^($\phi 63.66$)	58	$\phi 16$	$\phi 50$	23	35	38.95	29.83	14	-	-	-	49°30'	$\phi 34.4$	0.52
M3S 20L - 5816	1	20	$\phi 60$	$\phi 61.39$ ^($\phi 63.66$)	58	$\phi 16$	$\phi 50$	23	35	38.95	29.83	14	-	-	-	49°30'	$\phi 34.4$	0.52
M3S 20R - 5816H	1	20	$\phi 60$	$\phi 61.39$ ^($\phi 63.66$)	58	$\phi 16(H8)$	$\phi 50$	23	35	38.95	29.83	14	-	-	-	49°30'	$\phi 34.4$	0.52
M3S 20L - 5816H	1	20	$\phi 60$	$\phi 61.39$ ^($\phi 63.66$)	58	$\phi 16(H8)$	$\phi 50$	23	35	38.95	29.83	14	-	-	-	49°30'	$\phi 34.4$	0.52
M3S 20R # 5825H	1	20	$\phi 60$	$\phi 61.39$ ^($\phi 63.66$)	58	$\phi 25(H8)$	$\phi 50$	23	35	38.95	29.83	14	8 × 3.3	2-M6	11.5	49°30'	$\phi 34.4$	0.44
M3S 20L # 5825H	1	20	$\phi 60$	$\phi 61.39$ ^($\phi 63.66$)	58	$\phi 25(H8)$	$\phi 50$	23	35	38.95	29.83	14	8 × 3.3	2-M6	11.5	49°30'	$\phi 34.4$	0.44
M3S 30R - 7522	1	30	$\phi 90$	$\phi 91.28$ ^($\phi 93.46$)	75	$\phi 22$	$\phi 66$	24	40	44.38	31.73	18.6	-	-	-	47°11'	$\phi 57.4$	1.19
M3S 30L - 7522	1	30	$\phi 90$	$\phi 91.28$ ^($\phi 93.46$)	75	$\phi 22$	$\phi 66$	24	40	44.38	31.73	18.6	-	-	-	47°11'	$\phi 57.4$	1.19
M3S 30R - 7522H	1	30	$\phi 90$	$\phi 91.28$ ^($\phi 93.46$)	75	$\phi 22(H8)$	$\phi 66$	24	40	44.38	31.73	18.6	-	-	-	47°11'	$\phi 57.4$	1.19
M3S 30L - 7522H	1	30	$\phi 90$	$\phi 91.28$ ^($\phi 93.46$)	75	$\phi 22(H8)$	$\phi 66$	24	40	44.38	31.73	18.6	-	-	-	47°11'	$\phi 57.4$	1.19
M3S 30R # 7530H	1	30	$\phi 90$	$\phi 91.28$ ^($\phi 93.46$)	75	$\phi 30(H8)$	$\phi 66$	24	40	44.38	31.73	18.6	8 × 3.3	2-M6	12	47°11'	$\phi 57.4$	1.08
M3S 30L # 7530H	1	30	$\phi 90$	$\phi 91.28$ ^($\phi 93.46$)	75	$\phi 30(H8)$	$\phi 66$	24	40	44.38	31.73	18.6	8 × 3.3	2-M6	12	47°11'	$\phi 57.4$	1.08

カタログ記号の末尾に【H】を付した商品は歯部高周波焼入済です。【H】: Gear tooth surface completed with induction hardening, Hardness HRC 47 to 53.
【#】(シャープ)にはキー材とセットスクリューが付いております。【#】: Gear with key way and threaded hole / with key and screw.

歯先円直径 da の () 内は理論値です。最大外径は軸心と平行に面取りしてありますので、理論値より小さくなっています。

The numeric indicated in the bracket () under the column. Outside diameter da has been machined flat. With this process, the outer diameter is smaller than the theory with respect to shaft center to parallel.

許容伝達動力表 (kW) 曲げ強さ

Allowable transfer capability table (kW) Bending Strength

商品記号 Catalogue Numbers	回転速度 (min ⁻¹) revolution/min						
	300	600	900	1,200	1,500	1,800	2,000
M3S 20R - 5816	1.006	1.777	2.370	3.008	3.632	4.247	4.651
M3S 20R - 5816H	0.878	1.582	2.146	2.674	3.155	-	-
M3S 30R - 7522	2.180	3.635	5.101	6.515	7.883	-	-
M3S 30R - 7522H	1.922	3.291	4.481	-	-	-	-

The above references are JGMA standard.

動力の換算式は P26 をご参照ください。Please refer to the conversion formulas of power on page P26.

許容伝達動力表 (kW) 歯面強さ

Allowable transfer capability table (kW) Surface Durability

商品記号 Catalogue Numbers	回転速度 (min ⁻¹) revolution/min						
	300	600	900	1,200	1,500	1,800	2,000
M3S 20R - 5816	0.146	0.263	0.360	0.469	0.580	0.696	0.774
M3S 20R - 5816H	0.387	0.719	0.993	1.253	1.493	-	-
M3S 30R - 7522	0.470	0.813	1.180	1.573	1.937	-	-
M3S 30R - 7522H	1.237	2.184	3.026	-	-	-	-

JIS B1704 3級 (歯部高周波焼入品:4級)
System of Accuracy: JIS B 1704 Class 3
(Induction hardened products: Class 4)



御注文には必ず“フルネームで商品記号”を明記してください。
Please refer to the catalogue reference while ordering.
 d_s の寸法は参考値です。
Dimension of d_s is for reference only.

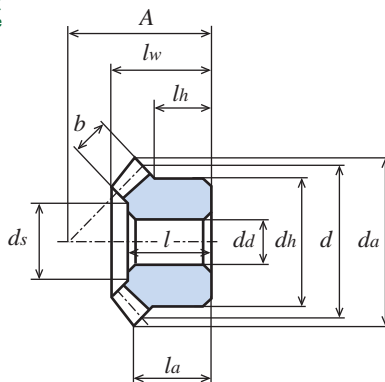

S45C 機械構造用炭素鋼 (JIS G 4051)

Material: Carbon Steel (ISO C45)

単位: mm
Dimensions: mm

商品記号 Catalogue Number	歯数比 Ratio u	歯数 Number of Teeth z	基準円直径 Reference Diameter d	歯先円直径 Tip Diameter d_a	組立距離 Locating Distance A	穴径 Bore Diameter $d_a(H7)$	ハブ外径 Hub Diameter d_h	ハブ長さ Hub Projection l_h	穴長さ Bore Length l	全長 Overall Length l_w	歯幅 Face Width b	キー溝 Key Way $b_2 \times t_2$	ねじ Set Screw		歯先角 Face Angle δ_a	ねじれ角 Spiral Angle d_s	重量 Weight $W(kg)$
													2-M	l_s			
B3S 18L - 15	2	18	$\phi 54$	$\phi 57.37$ <small>($\phi 60.07$)</small>	75.27	$\phi 15$	$\phi 41$	18.02	37	40.12	22.79	-	-	-	30° 9'	$\phi 27.5$	0.39
B3S 18L - 15H	2	18	$\phi 54$	$\phi 57.37$ <small>($\phi 60.07$)</small>	75.27	$\phi 15(H8)$	$\phi 41$	18.02	37	40.12	22.79	-	-	-	30° 9'	$\phi 27.5$	0.39
B3S 18L # 20H	2	18	$\phi 54$	$\phi 57.37$ <small>($\phi 60.07$)</small>	75.27	$\phi 20(H8)$	$\phi 41$	18.02	37	40.12	22.79	6 × 2.8	2-M6	9	30° 9'	$\phi 27.5$	0.35
B3S 36R - 16	2	36	$\phi 108$	$\phi 107.0$ <small>($\phi 109.47$)</small>	52.32	$\phi 16$	$\phi 60$	18	31	35.13	26.79	-	-	-	65° 22'	$\phi 68.9$	1.13
B3S 36R - 16H	2	36	$\phi 108$	$\phi 107.0$ <small>($\phi 109.47$)</small>	52.32	$\phi 16(H8)$	$\phi 60$	18	31	35.13	26.79	-	-	-	65° 22'	$\phi 68.9$	1.13
B3S 36R # 30H	2	36	$\phi 108$	$\phi 107.0$ <small>($\phi 109.47$)</small>	52.32	$\phi 30(H8)$	$\phi 60$	18	31	35.13	26.79	8 × 3.3	2-M6	9	65° 22'	$\phi 68.9$	1.01
B3S 15L - 12	3	15	$\phi 45$	$\phi 50.39$ <small>($\phi 52.16$)</small>	89.36	$\phi 12(H8)$	$\phi 36$	20.36	42	43.40	23.05	-	-	-	22° 44'	$\phi 26.7$	0.33
B3S 15L - 12H	3	15	$\phi 45$	$\phi 50.39$ <small>($\phi 52.16$)</small>	89.36	$\phi 12(H8)$	$\phi 36$	20.36	42	43.40	23.05	-	-	-	22° 44'	$\phi 26.7$	0.33
B3S 45R - 18	3	45	$\phi 135$	$\phi 133.9$ <small>($\phi 136.07$)</small>	50.95	$\phi 18$	$\phi 70$	18	31	36.06	30.06	-	-	-	74° 12'	$\phi 90.3$	1.85
B3S 45R - 18H	3	45	$\phi 135$	$\phi 133.9$ <small>($\phi 136.07$)</small>	50.95	$\phi 18(H8)$	$\phi 70$	18	31	36.06	30.06	-	-	-	74° 12'	$\phi 90.3$	1.85

カタログ記号の末尾に【H】を付した商品は歯部高周波焼入済です。【H】: Gear tooth surface completed with induction hardening, Hardness HRC 47 to 53.
【#】(シャープ)にはキー材とセットスクリューが付いております。【#】: Gear with key way and threaded hole / with key and screw.

許容伝達動力表 (kW) 曲げ強さ

Allowable transfer capability table (kW) Bending Strength

商品記号 Catalogue Numbers	回転速度 (min ⁻¹) revolution/min						
	300	600	900	1,200	1,500	1,800	2,000
B3S 18L - 15	1.230	2.228	2.997	3.729	4.517	5.262	5.769
B3S 18L - 15H	1.074	1.976	2.701	3.349	3.968	4.549	-
B3S 15L - 12	1.111	2.093	2.855	3.490	4.190	4.897	5.349
B3S 15L - 12H	0.970	1.845	2.554	3.160	3.748	4.302	4.646

The above references are JGMA standard.

動力の換算式は P26 をご参照ください。Please refer to the conversion formulas of power on page P26.

許容伝達動力表 (kW) 歯面強さ

Allowable transfer capability table (kW) Surface Durability

商品記号 Catalogue Numbers	回転速度 (min ⁻¹) revolution/min						
	300	600	900	1,200	1,500	1,800	2,000
B3S 18L - 15	0.206	0.381	0.524	0.668	0.808	0.986	1.098
B3S 18L - 15H	0.550	1.044	1.453	1.825	2.183	2.523	-
B3S 15L - 12	0.163	0.313	0.434	0.541	0.662	0.785	0.871
B3S 15L - 12H	0.438	0.860	1.211	1.518	1.818	2.103	2.282

- 目次 CONTENTS
- インフォメーション INFORMATION
- ギヤボックス GEAR BOXES
- ノーバッキングスピギヤ ANTI BACKLASH SPIR GEAR
- 歯研歯車 GROUND SPUR GEARS
- 平歯車 SPUR GEARS
- 内歯車 INTERNAL GEARS
- 歯研ラック GROUND RACKS
- ラック RACKS
- へリカル・スクリューギヤ HELICAL GEARS AND SCREW GEARS
- ウォーム・ウォームギヤ WORMS AND WORM GEARS
- かな歯車 BEVEL GEARS
- スプロケット SPROCKETS
- 技術資料 REFERENCE DATA

マイタギヤ

MITER GEARS

モジュール 1
MODULE 1

圧力角 20° 歯数比 1:1
1:1 Ratio 20° PRESSURE ANGLE

JIS B1704 3級
System of Accuracy: JIS B1704 Class 3



New **ねじを2箇所 (120°配) にしました。**
締結力が**1.6倍**になりました。
New item with two threaded holes (120°)
Tightening power increased by 1.6 times.

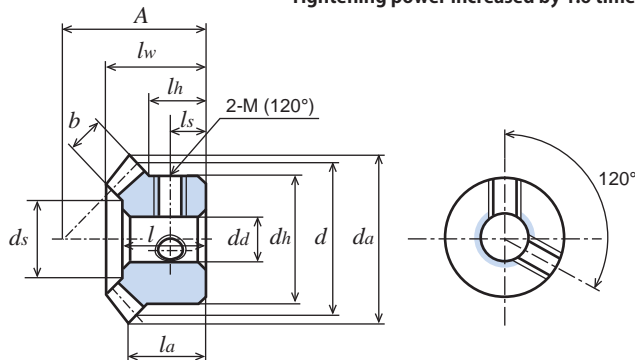

S45C 機械構造用炭素鋼 (JIS G 4051)
Material: Carbon Steel (ISO C45)

単位: mm
Dimensions: mm

商品記号 Catalogue Number	歯数比 Ratio <i>u</i>	歯数 Number of Teeth <i>z</i>	基準円直径 Reference Diameter <i>d</i>	歯先円直径 Tip Diameter <i>da</i>	組立距離 Locating Distance <i>A</i>	穴径 Bore Diameter <i>da(H7)</i>	ハブ外径 Hub Diameter <i>dh</i>	ハブ長さ Hub Projection <i>lh</i>	穴長さ Bore Length <i>l</i>	全長 Overall Length <i>lw</i>	Tip Distance <i>la</i>	歯幅 Face Width <i>b</i>	キミぞ Key Way <i>b2 × t2</i>	ねじ Set Screw		歯先角 Face Angle		重量 Weight <i>W(g)</i>
														2-M	<i>ls</i>	<i>δa</i>	<i>ds</i>	
M1S 20 - 2106	1	20	φ20	φ21.41	21	φ6	φ16	9	13	14.53	11.71	4.3	-	-	-	49° 3'	φ11.8	19.7
M1S 20 * 2106	1	20	φ20	φ21.41	21	φ6	φ16	9	13	14.53	11.71	4.3	-	2-M4	4.5	49° 3'	φ11.8	18.9
M1S 20 * 2108	1	20	φ20	φ21.41	21	φ8	φ16	9	13	14.53	11.71	4.3	-	2-M4	4.5	49° 3'	φ11.8	16.9
M1S 20 - 1406	1	20	φ20	φ21.41	14	φ6	φ16	2	6	7.53	4.71	4.3	-	-	-	49° 3'	φ11.8	10.2
M1S 20 = 1408	1	20	φ20	φ21.41	14	φ8	φ16	2	6	7.53	4.71	4.3	3 × 1.4	-	-	49° 3'	φ11.8	9.0
M1S 25 - 2306	1	25	φ25	φ26.41	23	φ6	φ20	8	13	14.7	11.21	5.3	-	-	-	48° 51'	φ15.0	33.2
M1S 25 * 2308	1	25	φ25	φ26.41	23	φ8	φ20	8	13	14.7	11.21	5.3	-	2-M4	4	48° 51'	φ15.0	30.0
M1S 25 * 2310	1	25	φ25	φ26.41	23	φ10	φ20	8	13	14.7	11.21	5.3	-	2-M4	4	48° 51'	φ15.0	27.3

【*】(アスタ)にはセットスクリューが2個付いております。[*]: Gear with two threaded holes / with two set screws.

許容伝達動力表 (W) 曲げ強さ

Allowable transfer capability table (W) Bending Strength

商品記号 Catalogue Numbers	回転速度 (min ⁻¹) revolution/min						
	10	100	200	400	600	800	1,000
M1S 20 - 2106	1.0	10.5	21.2	42.3	63.5	84.7	104.7
M1S 25 - 2306	1.7	17.5	35.0	70.0	105.0	139.9	169.1

The above numerical values are equivalent to JGMA formulas as reference only.

動力の換算式は P26 をご参照ください。

Please refer to the conversion formulas of power on page P26.

JIS B1704 3級
System of Accuracy: JIS B1704 Class 3



御注文には必ず“フルネームで商品記号”を明記してください。
Please refer to the catalogue reference while ordering.
 d_s の寸法は参考値です。
Dimension of d_s is for reference only.

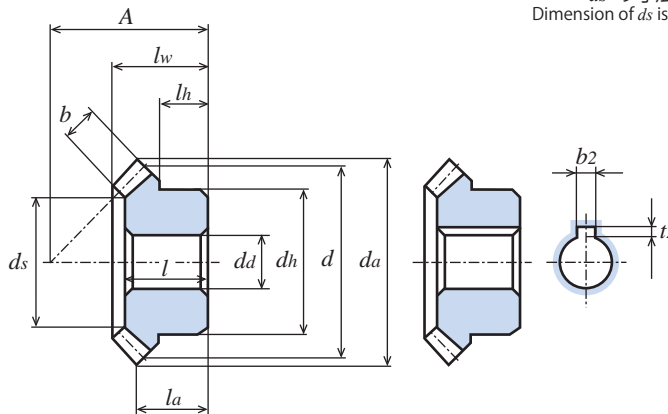

S45C 機械構造用炭素鋼 (JIS G 4051)

Material: Carbon Steel (ISO C45)

単位: mm
Dimensions: mm

商品記号 Catalogue Number	歯数比 Ratio u	歯数 Number of Teeth z	基準円直径 Reference Diameter d	歯先円直径 Tip Diameter d_a	組立距離 Locating Distance A	穴径 Bore Diameter $\phi da(H7)$	ハブ外径 Hub Diameter ϕdh	ハブ長さ Hub Projection lh	穴長さ Bore Length l	全長 Overall Length lw	Tip Distance la	歯幅 Face Width b	キミぞ Key Way $b_2 \times t_2$	ねじ Set Screw		歯先角 Face Angle δ_a	d_s	重量 Weight $W(g)$
														2-M	l_s			
M1S 30 - 2608	1	30	$\phi 30$	$\phi 31.41$	26	$\phi 8$	$\phi 22$	8.9	14.5	15.89	11.71	6.2	-	-	-	47°42'	$\phi 19.4$	46.4
M1S 30 * 2608	1	30	$\phi 30$	$\phi 31.41$	26	$\phi 8$	$\phi 22$	8.9	14.5	15.89	11.71	6.2	-	2-M5	4.5	47°42'	$\phi 19.4$	44.7
M1S 30 * 2610	1	30	$\phi 30$	$\phi 31.41$	26	$\phi 10$	$\phi 22$	8.9	14.5	15.89	11.71	6.2	-	2-M5	4.5	47°42'	$\phi 19.4$	41.8
M1S 30 * 2612	1	30	$\phi 30$	$\phi 31.41$	26	$\phi 12$	$\phi 22$	8.9	14.5	15.89	11.71	6.2	-	2-M5	4.5	47°42'	$\phi 19.4$	38.3
M1S 30 - 2008	1	30	$\phi 30$	$\phi 31.41$	20	$\phi 8$	$\phi 22$	2.9	8.5	9.89	5.71	6.2	-	-	-	47°42'	$\phi 19.4$	30.9
M1S 30 = 2010	1	30	$\phi 30$	$\phi 31.41$	20	$\phi 10$	$\phi 22$	2.9	8.5	9.89	5.71	6.2	3 × 1.4	-	-	47°42'	$\phi 19.4$	28.7
M1S 30 = 2012	1	30	$\phi 30$	$\phi 31.41$	20	$\phi 12$	$\phi 22$	2.9	8.5	9.89	5.71	6.2	4 × 1.8	-	-	47°42'	$\phi 19.4$	26.2

【*】(アスタ)にはセットスクリーが2個付いております。[*]: Gear with two threaded holes / with two set screws.

許容伝達動力表 (W) 曲げ強さ

Allowable transfer capability table (W) Bending Strength

商品記号 Catalogue Numbers	回転速度 (min ⁻¹) revolution/min						
	10	100	200	400	600	800	1,000
M1S 30 - 2608	2.6	26.2	52.4	104.7	157.2	202.7	241.9

The above numerical values are equivalent to JGMA formulas as reference only.

動力の換算式は P26 をご参照ください。

Please refer to the conversion formulas of power on page P26.

- 目次 CONTENTS
- インフォメーション INFORMATION
- ギヤボックス GEAR BOXES
- ノーバッキングミットギヤ ANTI BACKLASH MITER GEAR
- 歯研平歯車 GROUND SPUR GEARS
- 平歯車 SPUR GEARS
- 内歯車 INTERNAL GEARS
- 歯研ラック GROUND RACKS
- ラック RACKS
- へリカル・スクリューギヤ HELICAL GEARS AND SCREW GEARS
- ウォーム・ウォームギヤ WORMS AND WORM GEARS
- かな歯車 BEVEL GEARS
- スプロケット SPROCKETS
- 技術資料 REFERENCE DATA

JIS B1704 3級
System of Accuracy: JIS B1704 Class 3



New **ねじを2箇所 (120°配) にしました。**
締結力が1.6倍になりました。
New item with two threaded holes (120°)
Tightening power increased by 1.6 times.

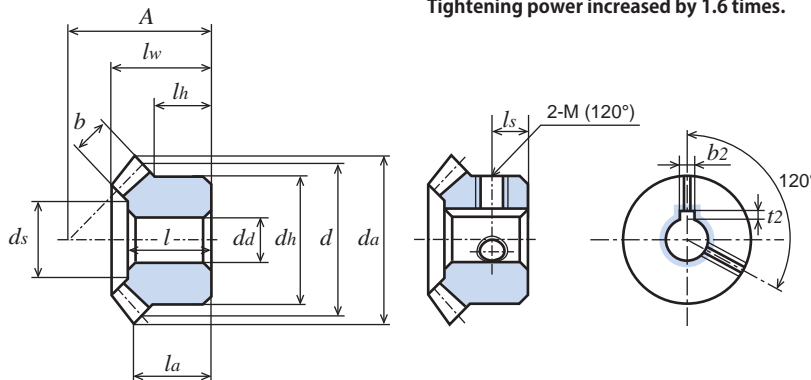

S45C 機械構造用炭素鋼 (JIS G 4051)

Material: Carbon Steel (ISO C45)

単位: mm
Dimensions: mm

商品記号 Catalogue Number	歯数比 Ratio <i>u</i>	歯数 Number of Teeth <i>z</i>	基準円直径 Reference Diameter <i>d</i>	歯先円直径 Tip Diameter <i>da</i>	組立距離 Locating Distance <i>A</i>	穴径 Bore Diameter <i>da(H7)</i>	ハブ外径 Hub Diameter <i>dh</i>	ハブ長さ Hub Projection <i>lh</i>	穴長さ Bore Length <i>l</i>	全長 Overall Length <i>lw</i>	Tip Distance <i>la</i>	歯幅 Face Width <i>b</i>	ねじ Set Screw		歯先角 Face Angle <i>δ_a</i>	<i>ds</i>	重量 Weight <i>W(g)</i>
													<i>M</i>	<i>ls</i>			
B1S 20 - 6	2	20	φ20	φ21.79	29.6	φ 6	φ16	8.6	14	15.03	10.05	5.7	-	-	29° 8'	φ12.1	21.3
B1S 20 * 6	2	20	φ20	φ21.79	29.6	φ 6	φ16	8.6	14	15.03	10.05	5.7	2-M4	4	29° 8'	φ12.1	20.5
B1S 20 * 8	2	20	φ20	φ21.79	29.6	φ 8	φ16	8.6	14	15.03	10.05	5.7	2-M4	4	29° 8'	φ12.1	18.3
B1S 40 - 8	2	40	φ40	φ40.89	21.8	φ 8	φ25	8	13	15.02	12.69	5.7	-	-	66° 0'	φ28.4	71.7
B1S 40 * 8	2	40	φ40	φ40.89	21.8	φ 8	φ25	8	13	15.02	12.69	5.7	2-M5	4	66° 0'	φ28.4	69.6
B1S 40 * 10	2	40	φ40	φ40.89	21.8	φ10	φ25	8	13	15.02	12.69	5.7	2-M5	4	66° 0'	φ28.4	67.0
B1S 15 - 6	3	15	φ15	φ17.67	31	φ 6	φ13	8.17	14.4	15.16	8.95	6.7	-	-	22°17'	φ 8.0	12.0
B1S 15 * 6	3	15	φ15	φ17.67	31	φ 6	φ13	8.17	14.4	15.16	8.95	6.7	2-M4	4	22°17'	φ 8.0	11.4
B1S 45 - 10	3	45	φ45	φ45.37	20	φ10	φ25	8	12.9	14.97	13.06	6.7	-	-	73°27'	φ31.1	86.0
B1S 45 * 10	3	45	φ45	φ45.37	20	φ10	φ25	8	12.9	14.97	13.06	6.7	2-M5	4	73°27'	φ31.1	84.2

【*】(アスタ)にはセットスクリーが2個付いております。【*】: Gear with two threaded holes / with two set screwsw.

許容伝達動力表 (W) 曲げ強さ

Allowable transfer capability table (kW) Bending Strength

商品記号 Catalogue Numbers	回転速度 (min ⁻¹) revolution/min						
	10	100	200	400	600	800	1,000
B1S 20 - 6	1.3	13.8	27.7	55.5	83.3	111.1	138.0
B1S 15 - 6	1.1	11.3	22.6	45.6	68.5	91.2	113.4

The above numerical values are equivalent to JGMA formulas as reference only.

動力の換算式は P26 をご参照ください。

Please refer to the conversion formulas of power on page P26.

JIS B1704 3級
System of Accuracy : JIS B1704 Class 3



御注文には必ず“フルネームで商品記号”を明記してください。
Please refer to the catalogue reference while ordering.
 d_s の寸法は参考値です。
Dimension of d_s is for reference only.

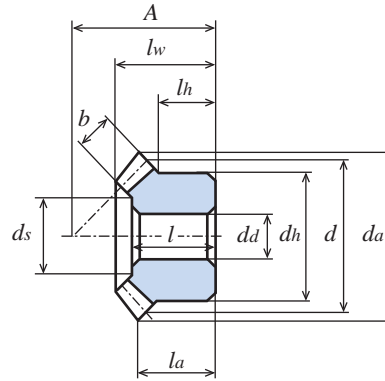

S45C 機械構造用炭素鋼 (JIS G 4051)

Material : Carbon Steel (ISO C45)

単位 : mm
Dimensions : mm

商品記号 Catalogue Number	歯数比 Ratio	歯数 Number of Teeth	基準円直径 Reference Diameter	歯先円直径 Tip Diameter	組立距離 Locating Distance	穴径 Bore Diameter	ハブ外径 Hub Diameter	ハブ長さ Hub Projection	穴長さ Bore Length	全長 Overall Length	Tip Distance	歯幅 Face Width	歯先角 Face Angle	d_s	重量 Weight
	u	z	d	d_a	A	$\phi d(H7)$	ϕd_h	l_h	l	l_w	l_a	b	δ_a	d_s	$W(g)$
M1.25S 20 - 2408	1	20	$\phi 25$	$\phi 26.77$	24	$\phi 8$	$\phi 20$	8.99	14	16	12.38	5.5	49° 3'	$\phi 14.4$	33.1
M1.25S 25 - 2808	1	25	$\phi 31.25$	$\phi 33.02$	28	$\phi 8$	$\phi 26$	9.75	15.5	17.35	13.26	6.2	48° 51'	$\phi 19.9$	64.0
M1.25S 30 - 3210	1	30	$\phi 37.5$	$\phi 39.27$	32	$\phi 10$	$\phi 28$	10	17	18.85	14.13	7	47° 42'	$\phi 25.2$	88.6

	歯数比 Ratio	ピッチ角 Pitch Angle		軸角 Shaft Angle
マイタギヤ Miter gear	1:1	45°		90°
ベベルギヤ Bevel gear	1:2	ピニオン ギヤ Pinion Gear	26° 34' 63° 26'	90°
	1:3	ピニオン ギヤ Pinion Gear	18° 26' 71° 34'	90°

許容伝達動力表 (W) 曲げ強さ

Allowable transfer capability table (kW) Bending Strength

商品記号 Catalogue Numbers	回転速度 (min ⁻¹) revolution/min						
	10	100	200	400	600	800	1,000
M1.25S 20 - 2408	2.0	20.9	41.9	83.9	125.9	167.1	206.7
M1.25S 25 - 2808	3.2	32.5	65.0	130.2	195.0	249.6	298.2
M1.25S 30 - 3210	4.6	46.9	93.9	187.7	274.3	347.8	414.3

The above numerical values are equivalent to JGMA formulas as reference only.
動力の換算式は P26 をご参照ください。
Please refer to the conversion formulas of power on page P26.

マイタギヤ

MITER GEARS

モジュール **1.5**
MODULE

圧力角 20° 歯数比 1:1
1:1 Ratio 20° PRESSURE ANGLE

JIS B1704 3級 (歯部高周波焼入品:4級)
System of Accuracy: JIS B 1704 Class 3
(Induction hardened products: Class 4)



New 仕様変更 締結加工不要。
Additional machining on tightening is not necessary.

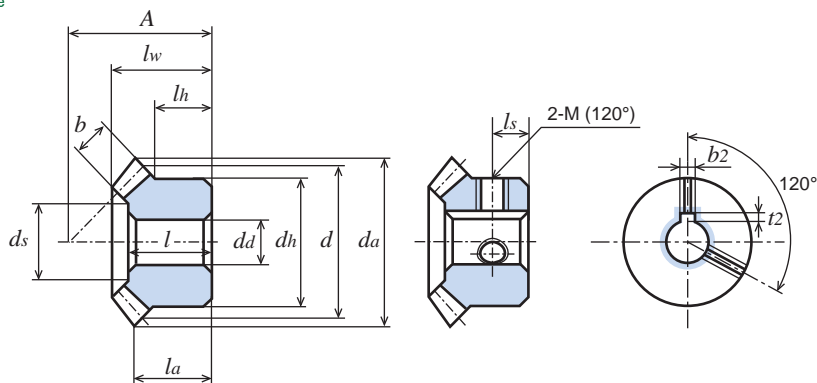

S45C 機械構造用炭素鋼 (JIS G 4051)

Material: Carbon Steel (ISO C45)

単位: mm
Dimensions: mm

商品記号 Catalogue Number	歯数比 Ratio	歯数 Number of Teeth	基準円直径 Reference Diameter	歯先円直径 Tip Diameter	組立距離 Locating Distance	穴径 Bore Diameter	ハブ外径 Hub Diameter	ハブ長さ Hub Projection	穴長さ Bore Length	全長 Overall Length	Tip Distance	歯幅 Face Width	キミぞ Key Way	ねじ Set Screw		歯先角 Face Angle	重量 Weight	
														2-M	ls			δa
M1.5S 20 - 2810	1	20	φ30	φ32.12	28	φ10	φ24	10	16.5	18.53	14.06	6.8	-	-	-	49° 3'	φ17.7	54.9
M1.5S 20 - 2810H	1	20	φ30	φ32.12	28	φ10(H8)	φ24	10	16.5	18.53	14.06	6.8	-	-	-	49° 3'	φ17.7	54.9
M1.5S 20 # 2810H	1	20	φ30	φ32.12	28	φ10(H8)	φ24	10	16.5	18.53	14.06	6.8	3 × 1.4	2-M4	5	49° 3'	φ17.7	53.7
M1.5S 20 # 2812H	1	20	φ30	φ32.12	28	φ12(H8)	φ24	10	16.5	18.53	14.06	6.8	4 × 1.8	2-M4	5	49° 3'	φ17.7	49.0
M1.5S 20 - 2110	1	20	φ30	φ32.12	21	φ10	φ24	3	9	11	7.06	6	-	-	-	49° 3'	φ19.0	32.8
M1.5S 20 - 2110H	1	20	φ30	φ32.12	21	φ10(H8)	φ24	3	9	11	7.06	6	-	-	-	49° 3'	φ19.0	32.8
M1.5S 20 = 2110H	1	20	φ30	φ32.12	21	φ10(H8)	φ24	3	9	11	7.06	6	3 × 1.4	-	-	49° 3'	φ19.0	32.5
M1.5S 25 - 3410	1	25	φ37.5	φ39.62	34	φ10	φ30	11.5	19	21.26	16.31	7.5	-	-	-	48° 51'	φ23.7	106.5
M1.5S 25 - 3410H	1	25	φ37.5	φ39.62	34	φ10(H8)	φ30	11.5	19	21.26	16.31	7.5	-	-	-	48° 51'	φ23.7	106.5

カタログ記号の末尾に【H】を付した商品は歯部高周波焼入済です。【H】: Gear tooth surface completed with induction hardening, Hardness HRC 47 to 53.
【#】(シャープ)にはキー材とセットスクリューが付いております。【#】: Gear with key way and threaded hole / with key and screw.

許容伝達動力表 (W) 曲げ強さ

Allowable transfer capability table (W) Bending Strength

商品記号 Catalogue Numbers	回転速度 (min ⁻¹) revolution/min						
	10	100	200	400	600	800	1,000
M1.5S 20 - 2810	3.7	37.1	74.4	148.9	223.3	287.6	344.7
M1.5S 20 - 2810H	3.4	34.4	68.9	137.8	206.7	267.0	321.6
M1.5S 20 - 2110	3.3	33.5	67.0	134.1	201.1	259.2	310.8
M1.5S 20 - 2110H	3.1	31.7	63.5	127.0	190.5	246.2	296.4
M1.5S 25 - 3410	5.6	56.5	113.1	226.3	331.5	419.3	499.1
M1.5S 25 - 3410H	5.3	53.6	107.2	214.4	314.6	400.3	478.5

The above references are JGMA standard.

動力の換算式はP26をご参照ください。Please refer to the conversion formulas of power on page P26.

許容伝達動力表 (W) 歯面強さ

Allowable transfer capability table (W) Surface Durability

商品記号 Catalogue Numbers	回転速度 (min ⁻¹) revolution/min						
	10	100	200	400	600	800	1,000
M1.5S 20 - 2810	0.2	2.8	5.7	11.7	18.1	23.4	27.6
M1.5S 20 - 2810H	0.7	8.0	16.5	34.0	52.0	68.0	82.8
M1.5S 20 - 2110	0.2	2.6	5.3	10.6	15.5	20.8	25.1
M1.5S 20 - 2110H	0.6	7.4	15.2	31.4	48.0	62.8	76.4
M1.5S 25 - 3410	0.5	5.1	10.5	21.3	31.4	40.2	48.4
M1.5S 25 - 3410H	1.3	14.7	30.4	62.7	93.6	120.6	145.6

JIS B1704 3級 (歯部高周波焼入品:4級)
System of Accuracy: JIS B 1704 Class 3
(Induction hardened products: Class 4)



御注文には必ず“フルネームで商品記号”を明記してください。
Please refer to the catalogue reference while ordering.
 d_s の寸法は参考値です。
Dimension of d_s is for reference only.

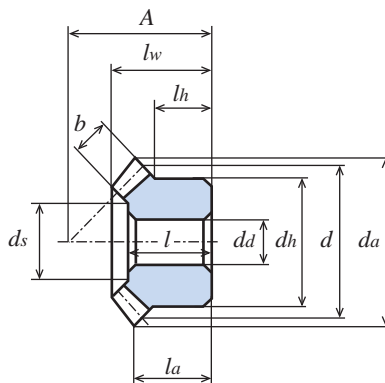

S45C 機械構造用炭素鋼 (JIS G 4051)

Material: Carbon Steel (ISO C45)

単位: mm
Dimensions: mm

商品記号 Catalogue Number	歯数比 Ratio u	歯数 Number of Teeth z	基準円直径 Reference Diameter d	歯先円直径 Tip Diameter d_a	組立距離 Locating Distance A	穴径 Bore Diameter $d_d(H7)$	ハブ外径 Hub Diameter d_h	ハブ長さ Hub Projection l_h	穴長さ Bore Length l	全長 Overall Length l_w	Tip Distance l_a	歯幅 Face Width b	キーマ みぞ Key Way $b_2 \times t_2$	ねじ Set Screw		歯先角 Face Angle δ_a	d_s	重量 Weight $W(g)$
														2-M	l_s			
M1.5S 30 - 3812	1	30	$\phi 45$	$\phi 47.12$	38	$\phi 12$	$\phi 33$	12.34	21	22.83	16.56	9.3	-	-	-	47°42'	$\phi 29.6$	152.0
M1.5S 30 - 3812H	1	30	$\phi 45$	$\phi 47.12$	38	$\phi 12(H8)$	$\phi 33$	12.34	21	22.83	16.56	9.3	-	-	-	47°42'	$\phi 29.6$	152.0
M1.5S 30 # 3812H	1	30	$\phi 45$	$\phi 47.12$	38	$\phi 12(H8)$	$\phi 33$	12.34	21	22.83	16.56	9.3	4 × 1.8	2-M4	6.5	47°42'	$\phi 29.6$	150.1
M1.5S 30 # 3815H	1	30	$\phi 45$	$\phi 47.12$	38	$\phi 15(H8)$	$\phi 33$	12.34	21	22.83	16.56	9.3	5 × 2.3	2-M4	6.5	47°42'	$\phi 29.6$	139.0
M1.5S 30 # 3816H	1	30	$\phi 45$	$\phi 47.12$	38	$\phi 16(H8)$	$\phi 33$	12.34	21	22.83	16.56	9.3	5 × 2.3	2-M4	6.5	47°42'	$\phi 29.6$	135.0

カタログ記号の末尾に【H】を付した商品は歯部高周波焼入済です。[H]: Gear tooth surface completed with induction hardening, Hardness HRC 47 to 53.
【#】(シャープ)にはキー材とセットスクリーが付いております。[#]: Gear with key way and threaded hole / with key and screw.

許容伝達動力表 (W) 曲げ強さ

Allowable transfer capability table (W) Bending Strength

商品記号 Catalogue Numbers	回転速度 (min ⁻¹) revolution/min						
	10	100	200	400	600	800	1,000
M1.5S 30 - 3812	8.8	88.3	176.7	353.5	501.8	630.0	744.7
M1.5S 30 - 3812H	8.3	83.2	166.5	333.1	475.1	599.9	712.1

The above references are JGMA standard.

動力の換算式は P26 をご参照ください。Please refer to the conversion formulas of power on page P26.

許容伝達動力表 (W) 歯面強さ

Allowable transfer capability table (W) Surface Durability

商品記号 Catalogue Numbers	回転速度 (min ⁻¹) revolution/min						
	10	100	200	400	600	800	1,000
M1.5S 30 - 3812	0.9	9.5	19.1	38.7	55.6	70.7	84.4
M1.5S 30 - 3812H	2.3	26.4	54.5	112.5	163.3	208.9	250.4

- 目次 CONTENTS
- インフォメーション INFORMATION
- ギヤボックス GEAR BOXES
- ノーバッキングミタギヤ ANTI BACKLASH MITER GEARS
- 歯研平歯車 GROUND SPUR GEARS
- 平歯車 SPUR GEARS
- 内歯車 INTERNAL GEARS
- 歯研ラック GROUND RACKS
- ラック RACKS
- へリカル・スクリューギヤ HELICAL GEARS AND SCREW GEARS
- ウォーム・ウォームギヤ WORMS AND WORM GEARS
- かな歯車 BEVEL GEARS
- スプロケット SPROCKETS
- 技術資料 REFERENCE DATA

ベベルギヤ

BEVEL GEARS

モジュール **1.5**
MODULE

圧力角 20° 歯数比 1:2
1:2 Ratio 20° PRESSURE ANGLE

JIS B1704 3級 (歯部高周波焼入品:4級)
System of Accuracy: JIS B 1704 Class 3
(Induction hardened products: Class 4)



仕様変更 締結加工不要。
Additional machining on tightening is not necessary.

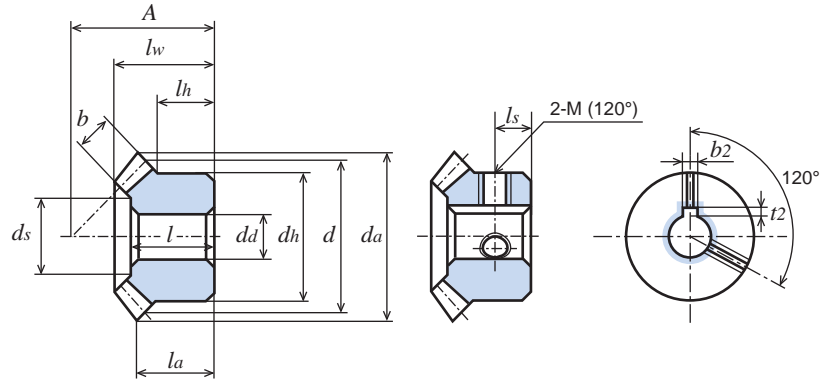

S45C 機械構造用炭素鋼 (JIS G 4051)
Material: Carbon Steel (ISO C45)

単位: mm
Dimensions: mm

商品記号 Catalogue Number	歯数比 Ratio	歯数 Number of Teeth	基準円直径 Reference Diameter	歯先円直径 Tip Diameter	組立距離 Locating Distance	穴径 Bore Diameter	ハブ外径 Hub Diameter	ハブ長さ Hub Projection	穴長さ Bore Length	全長 Overall Length	歯幅 Face Width	ねじ Set Screw	歯先角 Face Angle	重量 Weight	
															キー Key Way
B1.5S 18 - 8	2	18	φ27	φ29.68	40.74	φ8	φ22	12.5	21	22.96	14.41	-	29°25'	φ12.2	59.4
B1.5S 18 - 8H	2	18	φ27	φ29.68	40.74	φ8 (H8)	φ22	12.5	21	22.96	14.41	-	29°25'	φ12.2	59.4
B1.5S 18 # 10H	2	18	φ27	φ29.68	40.74	φ10 (H8)	φ22	12.5	21	22.96	14.41	3 × 1.4	29°25'	φ12.2	54.5
B1.5S 36 - 10	2	36	φ54	φ55.34	26.75	φ10	φ30	10	15.5	18.54	14.59	-	66°17'	φ34.3	139.9
B1.5S 36 - 10H	2	36	φ54	φ55.34	26.75	φ10 (H8)	φ30	10	15.5	18.54	14.59	-	66°17'	φ34.3	139.9
B1.5S 36 # 10H	2	36	φ54	φ55.34	26.75	φ10 (H8)	φ30	10	15.5	18.54	14.59	3 × 1.4	66°17'	φ34.3	138.6
B1.5S 36 # 15H	2	36	φ54	φ55.34	26.75	φ15 (H8)	φ30	10	15.5	18.54	14.59	5 × 2.3	66°17'	φ34.3	126.0

カタログ記号の末尾に【H】を付した商品は歯部高周波焼入済です。【H】: Gear tooth surface completed with induction hardening, Hardness HRC 47 to 53.
【#】(シャープ)にはキー材とセットスクリューが付いております。【#】: Gear with key way and threaded hole / with key and screw.

許容伝達動力表 (W) 曲げ強さ

Allowable transfer capability table (W) Bending Strength

商品記号 Catalogue Numbers	回転速度 (min ⁻¹) revolution/min						
	10	100	200	400	600	800	1,000
B1.5S 18 - 8	4.4	44.4	88.8	170.3	255.4	334.6	403.0
B1.5S 18 - 8H	4.1	41.1	82.2	164.4	246.6	323.5	390.8

許容伝達動力表 (W) 歯面強さ

Allowable transfer capability table (W) Surface Durability

商品記号 Catalogue Numbers	回転速度 (min ⁻¹) revolution/min						
	10	100	200	400	600	800	1,000
B1.5S 18 - 8	0.3	3.9	7.6	15.8	23.9	31.4	38.1
B1.5S 18 - 8H	1.0	11.6	24.0	49.6	75.7	100.6	122.7

The above references are JGMA standard.

動力の換算式は P26 をご参照ください。Please refer to the conversion formulas of power on page P26.

JIS B1704 3級 (歯部高周波焼入品: 4級)
System of Accuracy: JIS B 1704 Class 3
(Induction hardened products: Class 4)



御注文には必ず“フルネームで商品記号”を明記してください。
Please refer to the catalogue reference while ordering.
 d_s の寸法は参考値です。
Dimension of d_s is for reference only.

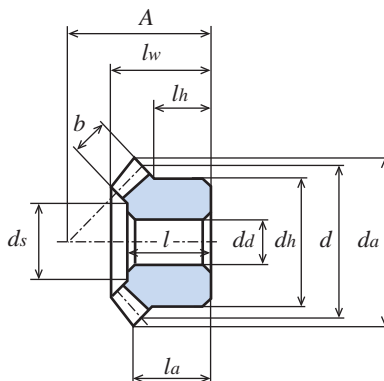

S45C 機械構造用炭素鋼 (JIS G 4051)

Material: Carbon Steel (ISO C45)

単位: mm
Dimensions: mm

商品記号 Catalogue Number	歯数比 Ratio u	歯数 Number of Teeth z	基準円直径 Reference Diameter d	歯先円直径 Tip Diameter d_a	組立距離 Locating Distance A	穴径 Bore Diameter $d_a(H7)$	ハブ外径 Hub Diameter d_h	ハブ長さ Hub Projection l_h	穴長さ Bore Length l	全長 Overall Length l_w	Tip Distance l_a	歯幅 Face Width b	キーマ みぞ Key Way $b_2 \times t_2$	ねじ Set Screw		歯先角 Face Angle δ_a	d_s	重量 Weight $W(g)$
														2-M	ls			
B1.5S 15 - 8	3	15	$\phi 22.5$	$\phi 26.51$	46	$\phi 8$	$\phi 19.5$	11.78	21.1	22.29	12.92	10.1	-	-	-	22°17'	$\phi 11.7$	41.8
B1.5S 15 - 8H	3	15	$\phi 22.5$	$\phi 26.51$	46	$\phi 8 (H8)$	$\phi 19.5$	11.78	21.1	22.29	12.92	10.1	-	-	-	22°17'	$\phi 11.7$	41.8
B1.5S 15 # 8H	3	15	$\phi 22.5$	$\phi 26.51$	46	$\phi 8 (H8)$	$\phi 19.5$	11.78	21.1	22.29	12.92	10.1	3 × 1.4	2-M4	6	22°17'	$\phi 11.7$	40.6
B1.5S 45 - 12	3	45	$\phi 67.5$	$\phi 68.06$	30	$\phi 12$	$\phi 37.5$	12	19.4	22.47	19.59	10.1	-	-	-	73°27'	$\phi 46.6$	300.8
B1.5S 45 - 12H	3	45	$\phi 67.5$	$\phi 68.06$	30	$\phi 12 (H8)$	$\phi 37.5$	12	19.4	22.47	19.59	10.1	-	-	-	73°27'	$\phi 46.6$	300.8
B1.5S 45 # 15H	3	45	$\phi 67.5$	$\phi 68.06$	30	$\phi 15 (H8)$	$\phi 37.5$	12	19.4	22.47	19.59	10.1	5 × 2.3	2-M4	6	73°27'	$\phi 46.6$	288.4
B1.5S 45 # 16H	3	45	$\phi 67.5$	$\phi 68.06$	30	$\phi 16 (H8)$	$\phi 37.5$	12	19.4	22.47	19.59	10.1	5 × 2.3	2-M4	6	73°27'	$\phi 46.6$	284.7

カタログ記号の末尾に【H】を付した商品は歯部高周波焼入済です。【H】: Gear tooth surface completed with induction hardening, Hardness HRC 47 to 53.
【#】(シャープ)にはキーマ材とセットスクリューが付いております。【#】: Gear with key way and threaded hole / with key and screw.

	歯数比 Ratio	ピッチ角 Pitch Angle		軸角 Shaft Angle
マイタギヤ Miter gear	1:1	45°		90°
ベベルギヤ Bevel gear	1:2	ピニオン ギヤ Pinion Gear	26° 34'	90°
		ギヤ Gear	63° 26'	
	1:3	ピニオン ギヤ Pinion Gear	18° 26'	90°
		ギヤ Gear	71° 34'	

許容伝達動力表 (W) 曲げ強さ

Allowable transfer capability table (W) Bending Strength

商品記号 Catalogue Numbers	回転速度 (min ⁻¹) revolution/min						
	10	100	200	400	600	800	1,000
B1.5S 15 - 8	3.8	38.4	76.9	153.9	230.9	307.8	375.9
B1.5S 15 - 8H	3.6	36.5	73.0	146.1	219.2	292.3	357.5

The above references are JGMA standard.

動力の換算式は P26 をご参照ください。Please refer to the conversion formulas of power on page P26.

許容伝達動力表 (W) 歯面強さ

Allowable transfer capability table (W) Surface Durability

	回転速度 (min ⁻¹) revolution/min						
	10	100	200	400	600	800	1,000
	0.3	3.2	6.4	13.0	19.6	26.3	32.2
	0.8	9.1	18.8	38.9	59.4	80.2	99.0

- 目次 CONTENTS
- インフォメーション INFORMATION
- ギヤボックス GEAR BOXES
- ノーバッキングスピギヤ ANTI BACKLASH SPUR GEARS
- 歯研平歯歯車 GROUND SPUR GEARS
- 平歯車 SPUR GEARS
- 内歯車 INTERNAL GEARS
- 歯研ラック GROUND RACKS
- ラック RACKS
- へリカル・スクリューギヤ HELICAL GEARS AND SCREW GEARS
- ウォーム・ウォームギヤ WORMS AND WORM GEARS
- かなめ歯車 BEVEL GEARS
- スプロケット SPROCKETS
- 技術資料 REFERENCE DATA

マイタギヤ

MITER GEARS

モジュール **2**
MODULE

圧力角 20° 歯数比 1 : 1
1 : 1 Ratio 20° PRESSURE ANGLE

JIS B1704 3級 (歯部高周波焼入品: 4級)
System of Accuracy: JIS B 1704 Class 3
(Induction hardened products: Class 4)



仕様変更 締結加工不要。
Additional machining on tightening is not necessary.

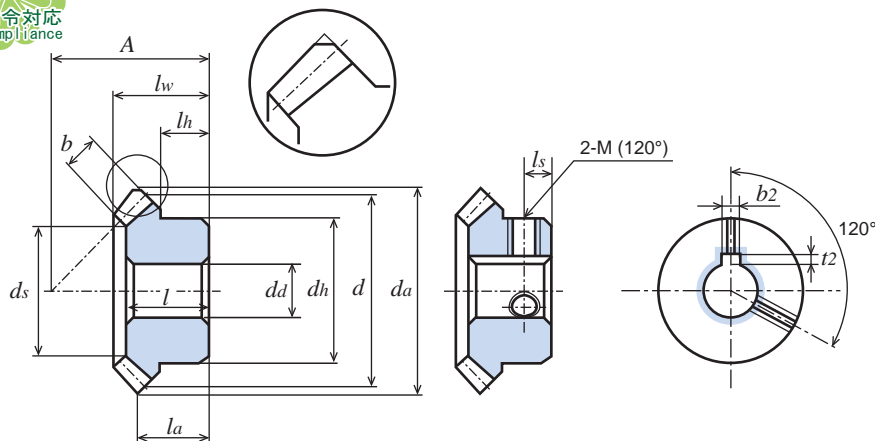

S45C 機械構造用炭素鋼 (JIS G 4051)
Material: Carbon Steel (ISO C45)

単位: mm
Dimensions: mm

商品記号 Catalogue Number	歯数比 Ratio	歯数 Number of Teeth	基準円直径 Reference Diameter	歯先円直径 Tip Diameter	組立距離 Locating Distance	穴径 Bore Diameter	ハブ外径 Hub Diameter	ハブ長さ Hub Projection	穴長さ Bore Length	全長 Overall Length	歯幅 Face Width	キミぞ Key Way	ねじ Set Screw		歯先角 Face Angle	重量 Weight	
													2-M	ls			da
M2S 20 - 3712	1	20	φ40	^(φ42.83) φ41.32	37	φ12	φ34	14	21	24	18.41	-	-	-	49° 3'	φ23.9	141.0
M2S 20 - 3712H	1	20	φ40	^(φ42.83) φ41.32	37	φ12(H8)	φ34	14	21	24	18.41	-	-	-	49° 3'	φ23.9	141.0
M2S 20 # 3712H	1	20	φ40	^(φ42.83) φ41.32	37	φ12(H8)	φ34	14	21	24	18.41	4 × 1.8	2-M5	7	49° 3'	φ23.9	138.4
M2S 20 # 3715H	1	20	φ40	^(φ42.83) φ41.32	37	φ15(H8)	φ34	14	21	24	18.41	5 × 2.3	2-M5	7	49° 3'	φ23.9	127.4
M2S 20 # 3716H	1	20	φ40	^(φ42.83) φ41.32	37	φ16(H8)	φ34	14	21	24	18.41	5 × 2.3	2-M5	7	49° 3'	φ23.9	123.5
M2S 20 - 2812	1	20	φ40	^(φ42.83) φ41.32	28	φ12	φ34	5	12	15	9.41	-	-	-	49° 3'	φ23.9	84.9
M2S 20 - 2812H	1	20	φ40	^(φ42.83) φ41.32	28	φ12(H8)	φ34	5	12	15	9.41	-	-	-	49° 3'	φ23.9	84.9
M2S 20 = 2812H	1	20	φ40	^(φ42.83) φ41.32	28	φ12(H8)	φ34	5	12	15	9.41	4 × 1.8	-	-	49° 3'	φ23.9	84.2
M2S 20 = 2815H	1	20	φ40	^(φ42.83) φ41.32	28	φ15(H8)	φ34	5	12	15	9.41	5 × 2.3	-	-	49° 3'	φ23.9	77.8
M2S 20 = 2816H	1	20	φ40	^(φ42.83) φ41.32	28	φ16(H8)	φ34	5	12	15	9.41	5 × 2.3	-	-	49° 3'	φ23.9	75.5
M2S 25 - 4012	1	25	φ50	^(φ52.83) φ51.33	40	φ12	φ42	10.99	21	23.34	16.41	-	-	-	48° 51'	φ32.3	227.0
M2S 25 - 4012H	1	25	φ50	^(φ52.83) φ51.33	40	φ12(H8)	φ42	10.99	21	23.34	16.41	-	-	-	48° 51'	φ32.3	227.0

カタログ記号の末尾に【H】を付した商品は歯部高周波焼入済です。【H】: Gear tooth surface completed with induction hardening, Hardness HRC 47 to 53.
【#】 (シャープ) にはキー材とセットスクリューが付いております。【#】: Gear with key way and threaded hole / with key and screw.

許容伝達動力表 (kW) 曲げ強さ

Allowable transfer capability table (kW) Bending Strength

商品記号 Catalogue Numbers	回転速度 (min ⁻¹) revolution/min						
	10	100	200	400	600	800	1,000
M2S 20 - 3712	0.008	0.083	0.167	0.334	0.484	0.611	0.726
M2S 20 - 3712H	0.007	0.078	0.156	0.313	0.455	0.578	0.689
M2S 25 - 4012	0.013	0.139	0.279	0.554	0.777	0.971	1.143
M2S 25 - 4012H	0.013	0.131	0.262	0.522	0.735	0.923	1.091

The above references are JGMA standard.

動力の換算式は P26 をご参照ください。Please refer to the conversion formulas of power on page P26.

許容伝達動力表 (kW) 歯面強さ

Allowable transfer capability table (kW) Surface Durability

商品記号 Catalogue Numbers	回転速度 (min ⁻¹) revolution/min						
	10	100	200	400	600	800	1,000
M2S 20 - 3712	0.001	0.006	0.013	0.027	0.040	0.051	0.061
M2S 20 - 3712H	0.001	0.018	0.038	0.079	0.117	0.151	0.182
M2S 25 - 4012	0.001	0.013	0.026	0.054	0.076	0.097	0.115
M2S 25 - 4012H	0.003	0.037	0.076	0.156	0.224	0.285	0.340

JIS B1704 3級 (歯部高周波焼入品 : 4級)
System of Accuracy : JIS B 1704 Class 3
(Induction hardened products : Class 4)



御注文には必ず“フルネームで商品記号”を明記してください。
Please refer to the catalogue reference while ordering.
 d_s の寸法は参考値です。
Dimension of d_s is for reference only.

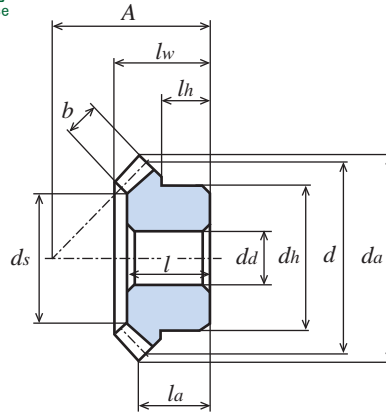

S45C 機械構造用炭素鋼 (JIS G 4051)

Material : Carbon Steel (ISO C45)

単位 : mm
Dimensions : mm

商品記号 Catalogue Number	歯数比 Ratio u	歯数 Number of Teeth z	基準円直径 Reference Diameter d	歯先円直径 Tip Diameter d_a	組立距離 Locating Distance A	穴径 Bore Diameter $d_d(H7)$	ハブ外径 Hub Diameter d_h	ハブ長さ Hub Projection l_h	穴長さ Bore Length l	全長 Overall Length l_w	Tip Distance l_a	歯幅 Face Width b	キーマイぞ Key Way $b_2 \times t_2$	ねじ Set Screw		歯先角 Face Angle δ_a	d_s	重量 Weight $W(g)$
														2-M	l_s			
M2S 30 - 5116	1	30	$\phi 60$	$\phi 61.36^{(\phi 62.83)}$	51	$\phi 16$	$\phi 44$	16.79	28	30.77	22.41	12.4	-	-	-	47°42'	$\phi 38.9$	361.4
M2S 30 - 5116H	1	30	$\phi 60$	$\phi 61.36^{(\phi 62.83)}$	51	$\phi 16(H8)$	$\phi 44$	16.79	28	30.77	22.41	12.4	-	-	-	47°42'	$\phi 38.9$	361.4
M2S 30 # 5118H	1	30	$\phi 60$	$\phi 61.36^{(\phi 62.83)}$	51	$\phi 18(H8)$	$\phi 44$	16.79	28	30.77	22.41	12.4	6 × 2.8	2-M5	8.5	47°42'	$\phi 38.9$	344.4
M2S 30 # 5120H	1	30	$\phi 60$	$\phi 61.36^{(\phi 62.83)}$	51	$\phi 20(H8)$	$\phi 44$	16.79	28	30.77	22.41	12.4	6 × 2.8	2-M5	8.5	47°42'	$\phi 38.9$	333.3

カタログ記号の末尾に【H】を付した商品は歯部高周波焼入済です。【H】: Gear tooth surface completed with induction hardening, Hardness HRC 47 to 53.
【#】(シャープ)にはキーマイぞとセットスクリューが付いております。【#】: Gear with key way and threaded hole / with key and screw.

歯先円直径 d_a の () 内は理論値です。最大外径は軸心と平行に面取りしてありますので、理論値より小さくなっています。

The numeric indicated in the bracket () under the column. Outside diameter d_a has been machined flat. With this process, the outer diameter is smaller than the theory with respect to shaft center to parallel.

許容伝達動力表 (kW) 曲げ強さ

Allowable transfer capability table (kW) Bending Strength

商品記号 Catalogue Numbers	回転速度 (min ⁻¹) revolution/min						
	10	100	200	400	600	800	1,000
M2S 30 - 5116	0.020	0.209	0.418	0.809	1.121	1.388	1.637
M2S 30 - 5116H	0.019	0.197	0.394	0.765	1.066	1.328	1.564

The above references are JGMA standard.

動力の換算式は P26 をご参照ください。Please refer to the conversion formulas of power on page P26.

許容伝達動力表 (kW) 歯面強さ

Allowable transfer capability table (kW) Surface Durability

商品記号 Catalogue Numbers	回転速度 (min ⁻¹) revolution/min						
	10	100	200	400	600	800	1,000
M2S 30 - 5116	0.002	0.023	0.047	0.092	0.129	0.163	0.195
M2S 30 - 5116H	0.005	0.064	0.132	0.265	0.376	0.474	0.564

ベベルギヤ

BEVEL GEARS

モジュール 2

MODULE

圧力角 20° 歯数比 1:2
1:2 Ratio 20° PRESSURE ANGLE

JIS B1704 3級 (歯部高周波焼入品:4級)
System of Accuracy: JIS B 1704 Class 3
(Induction hardened products: Class 4)



New 仕様変更 締結加工不要。
Additional machining on tightening is not necessary.

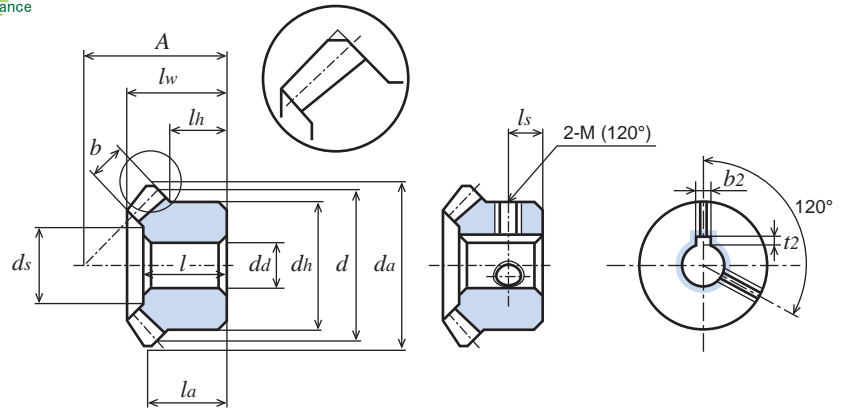

S45C 機械構造用炭素鋼 (JIS G 4051)

Material: Carbon Steel (ISO C45)

単位: mm
Dimensions: mm

商品記号 Catalogue Number	歯数比 Ratio	歯数 Number of Teeth	基準円直径 Reference Diameter	歯先円直径 Tip Diameter	組立距離 Locating Distance	穴径 Bore Diameter	ハブ外径 Hub Diameter	ハブ長さ Hub Projection	穴長さ Bore Length	全長 Overall Length	全長 Tip Distance	歯幅 Face Width	キミぞ Key Way	ねじ Set Screw		歯先角 Face Angle	歯先角 Face Angle	重量 Weight
														2-M	ls			
B2S 18 - 10	2	18	$\phi 36$	$\phi 37.81$ <small>($\phi 39.58$)</small>	53.12	$\phi 10$	$\phi 28$	15.12	27	29	18.01	12.6	-	-	-	29°25'	$\phi 19.1$	129.6
B2S 18 - 10H	2	18	$\phi 36$	$\phi 37.81$ <small>($\phi 39.58$)</small>	53.12	$\phi 10(H8)$	$\phi 28$	15.12	27	29	18.01	12.6	-	-	-	29°25'	$\phi 19.1$	129.6
B2S 18 # 12H	2	18	$\phi 36$	$\phi 37.81$ <small>($\phi 39.58$)</small>	53.12	$\phi 12(H8)$	$\phi 28$	15.12	27	29	18.01	12.6	4 × 1.8	2-M5	8	29°25'	$\phi 19.1$	119.8
B2S 36 - 12	2	36	$\phi 72$	$\phi 72.15$ <small>($\phi 73.79$)</small>	35.21	$\phi 12$	$\phi 36$	13	21	24.07	19	12.6	-	-	-	66°17'	$\phi 47.6$	313.0
B2S 36 - 12H	2	36	$\phi 72$	$\phi 72.15$ <small>($\phi 73.79$)</small>	35.21	$\phi 12(H8)$	$\phi 36$	13	21	24.07	19	12.6	-	-	-	66°17'	$\phi 47.6$	313.0
B2S 36 # 18H	2	36	$\phi 72$	$\phi 72.15$ <small>($\phi 73.79$)</small>	35.21	$\phi 18(H8)$	$\phi 36$	13	21	24.07	19	12.6	6 × 2.8	2-M5	6.5	66°17'	$\phi 47.6$	285.8
B2S 36 # 20H	2	36	$\phi 72$	$\phi 72.15$ <small>($\phi 73.79$)</small>	35.21	$\phi 20(H8)$	$\phi 36$	13	21	24.07	19	12.6	6 × 2.8	2-M5	6.5	66°17'	$\phi 47.6$	276.1

カタログ記号の末尾に【H】を付した商品は歯部高周波焼入済です。【H】: Gear tooth surface completed with induction hardening, Hardness HRC 47 to 53.
【#】(シャープ)にはキー材とセットスクリューが付いております。【#】: Gear with key way and threaded hole / with key and screw.

歯先円直径 da の () 内は理論値です。最大外径は軸心と平行に面取りしてありますので、理論値より小さくなっています。

The numeric indicated in the bracket () under the column. Outside diameter da has been machined flat. With this process, the outer diameter is smaller than the theory with respect to shaft center to parallel.

許容伝達動力表 (kW) 曲げ強さ

Allowable transfer capability table (kW) Bending Strength

商品記号 Catalogue Numbers	回転速度 (min ⁻¹) revolution/min						
	10	100	200	400	600	800	1,000
B2S 18 - 10	0.010	0.102	0.204	0.408	0.602	0.764	0.912
B2S 18 - 10H	0.009	0.095	0.190	0.380	0.562	0.716	0.857

The above references are JGMA standard.

動力の換算式は P26 をご参照ください。Please refer to the conversion formulas of power on page P26.

許容伝達動力表 (kW) 歯面強さ

Allowable transfer capability table (kW) Surface Durability

商品記号 Catalogue Numbers	回転速度 (min ⁻¹) revolution/min						
	10	100	200	400	600	800	1,000
B2S 18 - 10	0.010	0.102	0.204	0.408	0.602	0.764	0.912
B2S 18 - 10H	0.009	0.095	0.190	0.380	0.562	0.716	0.857

JIS B1704 3級 (歯部高周波焼入品:4級)
System of Accuracy: JIS B 1704 Class 3
(Induction hardened products: Class 4)



御注文には必ず“フルネームで商品記号”を明記してください。
Please refer to the catalogue reference while ordering.
 d_s の寸法は参考値です。
Dimension of d_s is for reference only.

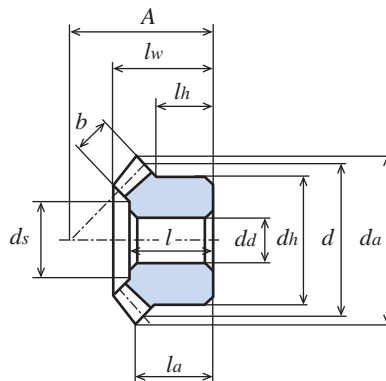

S45C 機械構造用炭素鋼 (JIS G 4051)

Material: Carbon Steel (ISO C45)

単位: mm
Dimensions: mm

商品記号 Catalogue Number	歯数比 Ratio u	歯数 Number of Teeth z	基準円直径 Reference Diameter d	歯先円直径 Tip Diameter d_a	組立距離 Locating Distance A	穴径 Bore Diameter $d_i(H7)$	ハブ外径 Hub Diameter d_h	ハブ長さ Hub Projection l_h	穴長さ Bore Length l	全長 Overall Length l_w	Tip Distance l_a	歯幅 Face Width b	キーマゾ Key Way $b_2 \times t_2$	ねじ Set Screw		歯先角 Face Angle δ_a	d_s	重量 Weight $W(g)$
														2-M	ls			
B2S 15 - 10	3	15	$\phi 30$	$\phi 34.19$ <small>($\phi 35.35$)</small>	62	$\phi 10$	$\phi 26$	16.33	28.9	30.32	17.89	13.4	-	-	-	22°17'	$\phi 16.6$	103.8
B2S 15 - 10H	3	15	$\phi 30$	$\phi 34.19$ <small>($\phi 35.35$)</small>	62	$\phi 10(H8)$	$\phi 26$	16.33	28.9	30.32	17.89	13.4	-	-	-	22°17'	$\phi 16.6$	103.8
B2S 15 # 12H	3	15	$\phi 30$	$\phi 34.19$ <small>($\phi 35.35$)</small>	62	$\phi 12(H8)$	$\phi 26$	16.33	28.9	30.32	17.89	13.4	4 × 1.8	2-M5	8.5	22°17'	$\phi 16.6$	93.4
B2S 45 - 14	3	45	$\phi 90$	$\phi 99.29$ <small>($\phi 100.75$)</small>	40	$\phi 14$	$\phi 50$	16	25.9	29.94	26.12	13.4	-	-	-	73°27'	$\phi 62.3$	722.7
B2S 45 - 14H	3	45	$\phi 90$	$\phi 99.29$ <small>($\phi 100.75$)</small>	40	$\phi 14(H8)$	$\phi 50$	16	25.9	29.94	26.12	13.4	-	-	-	73°27'	$\phi 62.3$	722.7
B2S 45 # 18H	3	45	$\phi 90$	$\phi 99.29$ <small>($\phi 100.75$)</small>	40	$\phi 18(H8)$	$\phi 50$	16	25.9	29.94	26.12	13.4	6 × 2.8	2-M5	8	73°27'	$\phi 62.3$	696.9
B2S 45 # 20H	3	45	$\phi 90$	$\phi 99.29$ <small>($\phi 100.75$)</small>	40	$\phi 20(H8)$	$\phi 50$	16	25.9	29.94	26.12	13.4	6 × 2.8	2-M5	8	73°27'	$\phi 62.3$	684.8

カタログ記号の末尾に【H】を付した商品は歯部高周波焼入済です。[H]: Gear tooth surface completed with induction hardening, Hardness HRC 47 to 53.
【#】(シャープ)にはキー材とセットスクリューが付いております。[#]: Gear with key way and threaded hole / with key and screw.

	歯数比 Ratio	ピッチ角 Pitch Angle		軸角 Shaft Angle
マイタギヤ Miter gear	1:1	45°		90°
ベベルギヤ Bevel gear	1:2	ピニオン ギヤ Pinion Gear	26° 34' 63° 26'	90°
	1:3	ピニオン ギヤ Pinion Gear	18° 26' 71° 34'	90°

許容伝達動力表 (kW) 曲げ強さ

Allowable transfer capability table (kW) Bending Strength

商品記号 Catalogue Numbers	回転速度 (min ⁻¹) revolution/min						
	10	100	200	400	600	800	1,000
B2S 15 - 10	0.009	0.091	0.182	0.364	0.546	0.703	0.844
B2S 15 - 10H	0.008	0.086	0.172	0.345	0.518	0.669	0.805

The above references are JGMA standard.

動力の換算式は P26 をご参照ください。Please refer to the conversion formulas of power on page P26.

許容伝達動力表 (kW) 歯面強さ

Allowable transfer capability table (kW) Surface Durability

商品記号 Catalogue Numbers	回転速度 (min ⁻¹) revolution/min						
	10	100	200	400	600	800	1,000
B2S 15 - 10	0.002	0.007	0.015	0.031	0.047	0.062	0.075
B2S 15 - 10H	0.002	0.022	0.045	0.094	0.144	0.188	0.229

マイタギヤ

MITER GEARS

モジュール **2.5**
MODULE

圧力角 20° 歯数比 1 : 1
1 : 1 Ratio 20° PRESSURE ANGLE

JIS B1704 3級 (歯部高周波焼入品: 4級)
System of Accuracy: JIS B 1704 Class 3
(Induction hardened products: Class 4)



New 仕様変更 締結加工不要。
Additional machining on tightening is not necessary.

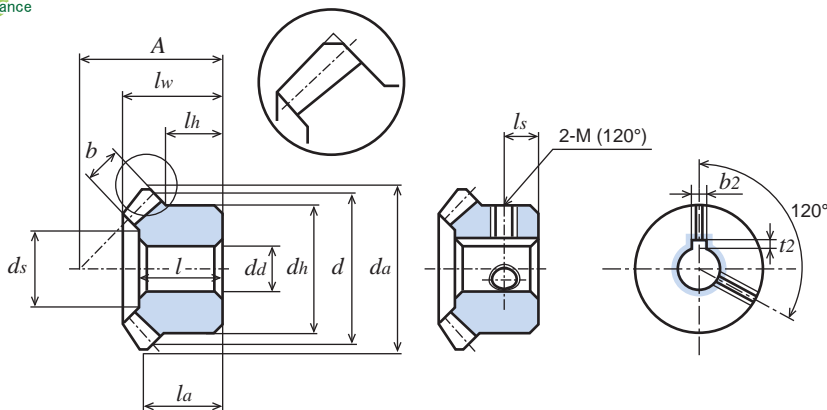

S45C 機械構造用炭素鋼 (JIS G 4051)
Material: Carbon Steel (ISO C45)

単位: mm
Dimensions: mm

商品記号 Catalogue Number	歯数比 Ratio	歯数 Number of Teeth	基準円直径 Reference Diameter	歯先円直径 Tip Diameter	組立距離 Locating Distance	穴径 Bore Diameter	ハブ外径 Hub Diameter	ハブ長さ Hub Projection	穴長さ Bore Length	全長 Overall Length	全長 Tip Distance	歯幅 Face Width	キミぞ Key Way	ねじ Set Screw		歯先角 Face Angle	歯先角 Face Angle	重量 Weight
														2-M	ls			
M2.5S 20 - 4814	1	20	φ50	φ51.66	48	φ14	φ42	19	28	32.06	24.77	11.1	-	-	-	49° 3'	φ28.5	294.0
M2.5S 20 - 4814H	1	20	φ50	φ51.66	48	φ14(H8)	φ42	19	28	32.06	24.77	11.1	-	-	-	49° 3'	φ28.5	294.0
M2.5S 20 # 4815H	1	20	φ50	φ51.66	48	φ15(H8)	φ42	19	28	32.06	24.77	11.1	5 × 2.3	2-M5	9.5	49° 3'	φ28.5	284.7
M2.5S 20 # 4816H	1	20	φ50	φ51.66	48	φ16(H8)	φ42	19	28	32.06	24.77	11.1	5 × 2.3	2-M5	9.5	49° 3'	φ28.5	279.5
M2.5S 20 # 4818H	1	20	φ50	φ51.66	48	φ18(H8)	φ42	19	28	32.06	24.77	11.1	6 × 2.8	2-M5	9.5	49° 3'	φ28.5	266.7
M2.5S 20 # 4820H	1	20	φ50	φ51.66	48	φ20(H8)	φ42	19	28	32.06	24.77	11.1	6 × 2.8	2-M5	9.5	49° 3'	φ28.5	253.7
M2.5S 20 - 3514	1	20	φ50	φ51.66	35	φ14	φ42	6	15	19.06	11.77	11.1	-	-	-	49° 3'	φ28.5	168.3
M2.5S 20 - 3514H	1	20	φ50	φ51.66	35	φ14(H8)	φ42	6	15	19.06	11.77	11.1	-	-	-	49° 3'	φ28.5	168.3
M2.5S 20 = 3515H	1	20	φ50	φ51.66	35	φ15(H8)	φ42	6	15	19.06	11.77	11.1	5 × 2.3	-	-	49° 3'	φ28.5	164.3
M2.5S 20 = 3518H	1	20	φ50	φ51.66	35	φ18(H8)	φ42	6	15	19.06	11.77	11.1	6 × 2.8	-	-	49° 3'	φ28.5	154.5
M2.5S 20 = 3520H	1	20	φ50	φ51.66	35	φ20(H8)	φ42	6	15	19.06	11.77	11.1	6 × 2.8	-	-	49° 3'	φ28.5	147.5
M2.5S 25 - 5016	1	25	φ62.5	φ64.16	50	φ16	φ52	13.5	27	29.42	20.52	13.5	-	-	-	48° 51'	φ40.8	441.2
M2.5S 25 - 5016H	1	25	φ62.5	φ64.16	50	φ16(H8)	φ52	13.5	27	29.42	20.52	13.5	-	-	-	48° 51'	φ40.8	441.2

カタログ記号の末尾に【H】を付した商品は歯部高周波焼入済です。【H】: Gear tooth surface completed with induction hardening, Hardness HRC 47 to 53.
【#】 (シャープ) にはキー材とセットスクリューが付いております。【#】: Gear with key way and threaded hole / with key and screw.

許容伝達動力表 (kW) 曲げ強さ

Allowable transfer capability table (kW) Bending Strength

商品記号 Catalogue Numbers	回転速度 (min ⁻¹) revolution/min						
	10	100	200	400	600	800	1,000
M2.5S 20 - 4814	0.016	0.169	0.338	0.672	0.941	1.177	1.385
M2.5S 20 - 4814H	0.015	0.157	0.314	0.626	0.881	1.108	1.309
M2.5S 25 - 5016	0.027	0.279	0.558	1.069	1.480	1.829	2.171
M2.5S 25 - 5016H	0.026	0.261	0.522	1.005	1.398	1.737	2.051

The above references are JGMA standard.

動力の換算式は P26 をご参照ください。Please refer to the conversion formulas of power on page P26.

許容伝達動力表 (kW) 歯面強さ

Allowable transfer capability table (kW) Surface Durability

商品記号 Catalogue Numbers	回転速度 (min ⁻¹) revolution/min						
	10	100	200	400	600	800	1,000
M2.5S 20 - 4814	0.001	0.013	0.028	0.056	0.080	0.101	0.121
M2.5S 20 - 4814H	0.003	0.038	0.079	0.162	0.232	0.295	0.353
M2.5S 25 - 5016	0.002	0.027	0.055	0.107	0.150	0.189	0.229
M2.5S 25 - 5016H	0.006	0.075	0.154	0.307	0.435	0.547	0.653

JIS B1704 3級 (歯部高周波焼入品: 4級)
System of Accuracy: JIS B 1704 Class 3
(Induction hardened products: Class 4)



御注文には必ず“フルネームで商品記号”を明記してください。
Please refer to the catalogue reference while ordering.
 d_s の寸法は参考値です。
Dimension of d_s is for reference only.

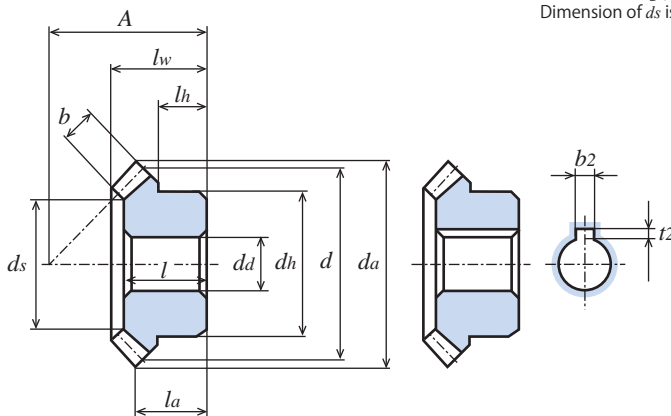

S45C 機械構造用炭素鋼 (JIS G 4051)

Material: Carbon Steel (ISO C45)

単位: mm
Dimensions: mm

商品記号 Catalogue Number	歯数比 Ratio	歯数 Number of Teeth	基準円直径 Reference Diameter	歯先円直径 Tip Diameter	組立距離 Locating Distance	穴径 Bore Diameter	ハブ外径 Hub Diameter	ハブ長さ Hub Projection	穴長さ Bore Length	全長 Overall Length	歯幅 Face Width	キー溝 Key Way	ねじ Set Screw		歯先角 Face Angle	重量 Weight		
													2-M	ls			δ_a	d_s
M2.5S 30 - 6318	1	30	$\phi 75$	$\phi 76.7$	63	$\phi 18$	$\phi 55$	20.5	34.5	37.71	27.27	15.5	-	-	47°42'	$\phi 49.1$	711.1	
M2.5S 30 - 6318H	1	30	$\phi 75$	$\phi 76.7$	63	$\phi 18(H8)$	$\phi 55$	20.5	34.5	37.71	27.27	15.5	-	-	47°42'	$\phi 49.1$	711.1	
M2.5S 30 # 6320H	1	30	$\phi 75$	$\phi 76.7$	63	$\phi 20(H8)$	$\phi 55$	20.5	34.5	37.71	27.27	15.5	6 × 2.8	2-M5	10.5	47°42'	$\phi 49.1$	688.1
M2.5S 30 # 6325H	1	30	$\phi 75$	$\phi 76.7$	63	$\phi 25(H8)$	$\phi 55$	20.5	34.5	37.71	27.27	15.5	8 × 3.3	2-M6	10.5	47°42'	$\phi 49.1$	637.2
M2.5S 30 - 5016	1	30	$\phi 75$	$\phi 76.7$	50	$\phi 16$	$\phi 55$	7.5	21.5	24.71	14.27	15.5	-	-	47°42'	$\phi 49.1$	503.6	
M2.5S 30 - 5016H	1	30	$\phi 75$	$\phi 76.7$	50	$\phi 16(H8)$	$\phi 55$	7.5	21.5	24.71	14.27	15.5	-	-	47°42'	$\phi 49.1$	503.6	
M2.5S 30 = 5020H	1	30	$\phi 75$	$\phi 76.7$	50	$\phi 20(H8)$	$\phi 55$	7.5	21.5	24.71	14.27	15.5	6 × 2.8	-	47°42'	$\phi 49.1$	481.7	
M2.5S 30 = 5025H	1	30	$\phi 75$	$\phi 76.7$	50	$\phi 25(H8)$	$\phi 55$	7.5	21.5	24.71	14.27	15.5	8 × 3.3	-	47°42'	$\phi 49.1$	450.9	

カタログ記号の末尾に【H】を付した商品は歯部高周波焼入済です。【H】: Gear tooth surface completed with induction hardening, Hardness HRC 47 to 53.
【#】(シャープ)にはキー材とセットスクリューが付いております。【#】: Gear with key way and threaded hole / with key and screw.

	歯数比 Ratio	ピッチ角 Pitch Angle	軸角 Shaft Angle
マイタギヤ Miter gear	1:1	45°	90°
ベベルギヤ Bevel gear	1:2	ピニオン ギヤ Pinion Gear	26° 34' 63° 26'
	1:3	ピニオン ギヤ Pinion Gear	18° 26' 71° 34'

許容伝達動力表 (kW) 曲げ強さ

Allowable transfer capability table (kW) Bending Strength

商品記号 Catalogue Numbers	回転速度 (min ⁻¹) revolution/min						
	10	100	200	400	600	800	1,000
M2.5S 30 - 6318	0.040	0.408	0.817	1.517	2.070	2.557	3.109
M2.5S 30 - 6318H	0.038	0.385	0.771	1.439	1.978	2.444	2.905

The above references are JGMA standard.

動力の換算式は P26 をご参照ください。Please refer to the conversion formulas of power on page P26.

許容伝達動力表 (kW) 歯面強さ

Allowable transfer capability table (kW) Surface Durability

商品記号 Catalogue Numbers	回転速度 (min ⁻¹) revolution/min						
	10	100	200	400	600	800	1,000
M2.5S 30 - 6318	0.004	0.046	0.094	0.177	0.247	0.312	0.387
M2.5S 30 - 6318H	0.011	0.128	0.264	0.509	0.712	0.891	1.069

- 目次 CONTENTS
- インフォメーション INFORMATION
- ギヤボックス GEAR BOXES
- ノーバッキングギヤ ANTI BACKLASH SPUR GEARS
- 歯研歯車 GROUND SPUR GEARS
- 平歯車 SPUR GEARS
- 内歯車 INTERNAL GEARS
- 歯研ラック GROUND RACKS
- ラック RACKS
- へリカル・スクリューギヤ HELICAL GEARS AND SCREW GEARS
- ウォーム・ウォームギヤ WORMS AND WORM GEARS
- かな歯車 BEVEL GEARS
- スプロケット SPURKETS
- 技術資料 REFERENCE DATA

JIS B1704 3級 (歯部高周波焼入品:4級)
System of Accuracy: JIS B 1704 Class 3
(Induction hardened products: Class 4)



仕様変更 締結加工不要。
Additional machining on tightening is not necessary.

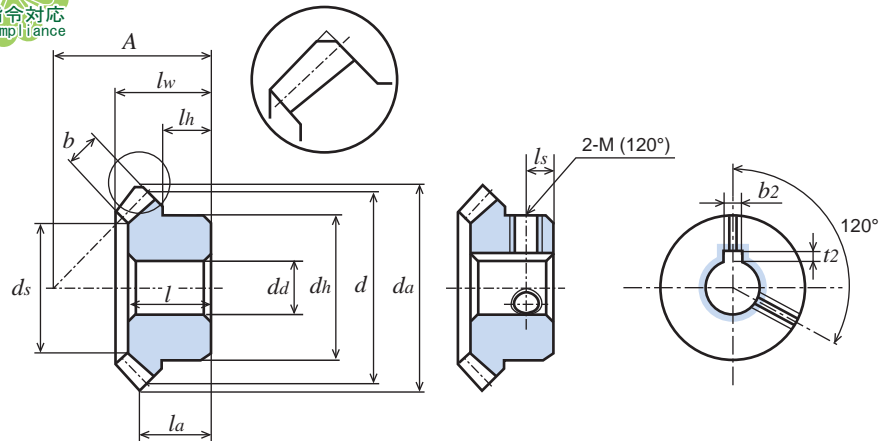

S45C 機械構造用炭素鋼 (JIS G 4051)

Material: Carbon Steel (ISO C45)

単位: mm
Dimensions: mm

商品記号 Catalogue Number	歯数比 Ratio	歯数 Number of Teeth	基準円直径 Reference Diameter	歯先円直径 Tip Diameter	組立距離 Locating Distance	穴径 Bore Diameter	ハブ外径 Hub Diameter	ハブ長さ Hub Projection	穴長さ Bore Length	全長 Overall Length	全長 Tip Distance	歯幅 Face Width	キミぞ Key Way	ねじ Set Screw		歯先角 Face Angle	歯先角 Face Angle	重量 Weight
														2-M	ls			
B2.5S 18 - 12	2	18	$\phi 45$	$\phi 47.27^{(\phi 49.47)}$	64.29	$\phi 12$	$\phi 36$	17	32	34.97	20.41	16.7	-	-	-	29°25'	$\phi 21.1$	0.25
B2.5S 18 - 12H	2	18	$\phi 45$	$\phi 47.27^{(\phi 49.47)}$	64.29	$\phi 12(H8)$	$\phi 36$	17	32	34.97	20.41	16.7	-	-	-	29°25'	$\phi 21.1$	0.25
B2.5S 18 # 15H	2	18	$\phi 45$	$\phi 47.27^{(\phi 49.47)}$	64.29	$\phi 15(H8)$	$\phi 36$	17	32	34.97	20.41	16.7	5 × 2.3	2-M5	8.5	29°25'	$\phi 21.1$	0.23
B2.5S 36 - 14	2	36	$\phi 90$	$\phi 90.18^{(\phi 92.24)}$	42.55	$\phi 14$	$\phi 50$	15	25	29.01	22.29	16.7	-	-	-	66°17'	$\phi 57.5$	0.64
B2.5S 36 - 14H	2	36	$\phi 90$	$\phi 90.18^{(\phi 92.24)}$	42.55	$\phi 14(H8)$	$\phi 50$	15	25	29.01	22.29	16.7	-	-	-	66°17'	$\phi 57.5$	0.64
B2.5S 36 # 20H	2	36	$\phi 90$	$\phi 90.18^{(\phi 92.24)}$	42.55	$\phi 20(H8)$	$\phi 50$	15	25	29.01	22.29	16.7	6 × 2.8	2-M5	7.5	66°17'	$\phi 57.5$	0.61
B2.5S 36 # 25H	2	36	$\phi 90$	$\phi 90.18^{(\phi 92.24)}$	42.55	$\phi 25(H8)$	$\phi 50$	15	25	29.01	22.29	16.7	8 × 3.3	2-M6	7.5	66°17'	$\phi 57.5$	0.57

カタログ記号の末尾に【H】を付した商品は歯部高周波焼入済です。【H】: Gear tooth surface completed with induction hardening, Hardness HRC 47 to 53.
【#】(シャープ)にはキー材とセットスクリューが付いております。【#】: Gear with key way and threaded hole / with key and screw.

歯先円直径 da の () 内は理論値です。最大外径は軸心と平行に面取りしてありますので、理論値より小さくなっています。
The numeric indicated in the bracket () under the column. Outside diameter da has been machined flat. With this process, the outer diameter is smaller than the theory with respect to shaft center to parallel.

許容伝達動力表 (kW) 曲げ強さ

Allowable transfer capability table (kW) Bending Strength

商品記号 Catalogue Numbers	回転速度 (min ⁻¹) revolution/min						
	10	100	200	400	600	800	1,000
B2.5S 18 - 12	0.020	0.209	0.418	0.837	1.189	1.494	1.767
B2.5S 18 - 12H	0.019	0.192	0.385	0.771	1.100	1.389	1.649

許容伝達動力表 (kW) 歯面強さ

Allowable transfer capability table (kW) Surface Durability

商品記号 Catalogue Numbers	回転速度 (min ⁻¹) revolution/min						
	10	100	200	400	600	800	1,000
B2.5S 18 - 12	0.002	0.021	0.042	0.085	0.122	0.155	0.186
B2.5S 18 - 12H	0.005	0.057	0.118	0.243	0.353	0.452	0.542

The above references are JGMA standard.

動力の換算式は P26 をご参照ください。Please refer to the conversion formulas of power on page P26.

JIS B1704 3級 (歯部高周波焼入品: 4級)
System of Accuracy: JIS B 1704 Class 3
(Induction hardened products: Class 4)



御注文には必ず“フルネームで商品記号”を明記してください。
Please refer to the catalogue reference while ordering.
 d_s の寸法は参考値です。
Dimension of d_s is for reference only.

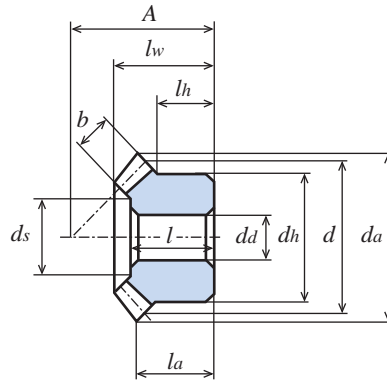

S45C 機械構造用炭素鋼 (JIS G 4051)

Material: Carbon Steel (ISO C45)

単位: mm
Dimensions: mm

商品記号 Catalogue Number	歯数比 Ratio u	歯数 Number of Teeth z	基準円直径 Reference Diameter d	歯先円直径 Tip Diameter d_a	組立距離 Locating Distance A	穴径 Bore Diameter $d_a(H7)$	ハブ外径 Hub Diameter d_h	ハブ長さ Hub Projection l_h	穴長さ Bore Length l	全長 Overall Length l_w	歯幅 Face Width b	キーみぞ Key Way $b_2 \times t_2$	ねじ Set Screw		歯先角 Face Angle δ_a	d_s	重量 Weight $W(kg)$	
													2-M	l_s				
B2.5S 15 - 10	3	15	$\phi 37.5$	$\phi 42.74$ ^($\phi 44.18$)	77.93	$\phi 10(H8)$	$\phi 32$	20.8	38.5	40.41	22.79	19	-	-	22°17'	$\phi 18.2$	0.22	
B2.5S 15 - 10H	3	15	$\phi 37.5$	$\phi 42.74$ ^($\phi 44.18$)	77.93	$\phi 10(H8)$	$\phi 32$	20.8	38.5	40.41	22.79	19	-	-	22°17'	$\phi 18.2$	0.22	
B2.5S 15 # 15H	3	15	$\phi 37.5$	$\phi 42.74$ ^($\phi 44.18$)	77.93	$\phi 15(H8)$	$\phi 32$	20.8	38.5	40.41	22.79	19	5 × 2.3	2-M5	10.5	22°17'	$\phi 18.2$	0.19
B2.5S 45 - 16	3	45	$\phi 112.5$	$\phi 111.6$ ^($\phi 113.44$)	40.67	$\phi 16$	$\phi 60$	14	24.5	28.74	23.32	19	-	-	73°27'	$\phi 74.1$	1.10	
B2.5S 45 - 16H	3	45	$\phi 112.5$	$\phi 111.6$ ^($\phi 113.44$)	40.67	$\phi 16(H8)$	$\phi 60$	14	24.5	28.74	23.32	19	-	-	73°27'	$\phi 74.1$	1.10	
B2.5S 45 # 20H	3	45	$\phi 112.5$	$\phi 111.6$ ^($\phi 113.44$)	40.67	$\phi 20(H8)$	$\phi 60$	14	24.5	28.74	23.32	19	6 × 2.8	2-M5	7	73°27'	$\phi 74.1$	1.07
B2.5S 45 # 25H	3	45	$\phi 112.5$	$\phi 111.6$ ^($\phi 113.44$)	40.67	$\phi 25(H8)$	$\phi 60$	14	24.5	28.74	23.32	19	8 × 3.3	2-M6	7	73°27'	$\phi 74.1$	1.04

カタログ記号の末尾に【H】を付した商品は歯部高周波焼入済です。【H】: Gear tooth surface completed with induction hardening, Hardness HRC 47 to 53.
【#】(シャープ)にはキー材とセットスクリューが付いております。【#】: Gear with key way and threaded hole / with key and screw.

	歯数比 Ratio	ピッチ角 Pitch Angle		軸角 Shaft Angle
	マイタギヤ Miter gear	1:1	45°	
ベベルギヤ Bevel gear	1:2	ピニオン ギヤ Pinion Gear	26° 34' 63° 26'	90°
	1:3	ピニオン ギヤ Pinion Gear	18° 26' 71° 34'	90°

許容伝達動力表 (kW) 曲げ強さ

Allowable transfer capability table (kW) Bending Strength

商品記号 Catalogue Numbers	回転速度 (min ⁻¹) revolution/min						
	10	100	200	400	600	800	1,000
B2.5S 15 - 10	0.019	0.197	0.394	0.789	1.155	1.464	1.744
B2.5S 15 - 10H	0.018	0.183	0.366	0.732	1.074	1.366	1.633

The above references are JGMA standard.

動力の換算式は P26 をご参照ください。Please refer to the conversion formulas of power on page P26.

許容伝達動力表 (kW) 歯面強さ

Allowable transfer capability table (kW) Surface Durability

	回転速度 (min ⁻¹) revolution/min						
	10	100	200	400	600	800	1,000
	0.001	0.017	0.034	0.070	0.104	0.133	0.160
	0.004	0.047	0.098	0.203	0.304	0.392	0.473

マイタギヤ MITER GEARS

モジュール 3
MODULE 3

圧力角 20° 歯数比 1:1
1:1 Ratio 20° PRESSURE ANGLE

JIS B1704 3級 (歯部高周波焼入品:4級)
System of Accuracy: JIS B 1704 Class 3
(Induction hardened products: Class 4)



New 仕様変更 締結加工不要。
Additional machining on tightening is not necessary.

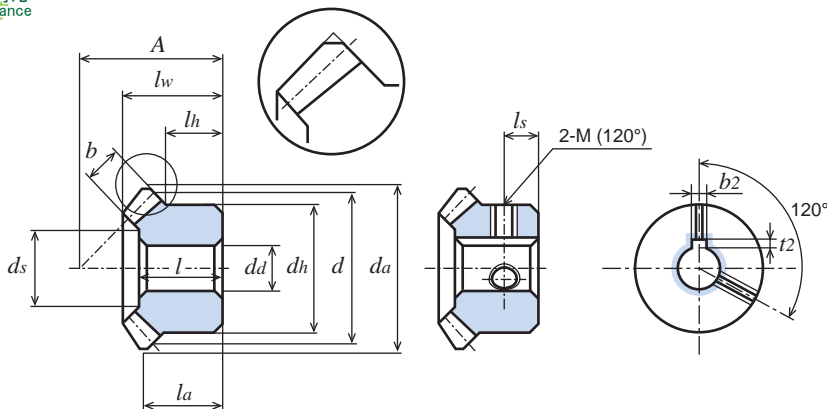

S45C 機械構造用炭素鋼 (JIS G 4051) Material: Carbon Steel (ISO C45)

単位: mm
Dimensions: mm

商品記号 Catalogue Number	歯数比 Ratio	歯数 Number of Teeth	基準円直径 Reference Diameter	歯先円直径 Tip Diameter	組立距離 Locating Distance	穴径 Bore Diameter	ハブ外径 Hub Diameter	ハブ長さ Hub Projection	穴長さ Bore Length	全長 Overall Length	Tip Distance	歯幅 Face Width	キミぞ Key Way	ねじ Set Screw		歯先角 Face Angle	重量 Weight	
														2-M	ls			δa
M3S 20 - 5816	1	20	φ60	(φ64.24) φ61.99	58	φ16	φ50	23	35	39.06	30.12	13.6	-	-	-	49° 3'	φ35.5	520.3
M3S 20 - 5816H	1	20	φ60	(φ64.24) φ61.99	58	φ16(H8)	φ50	23	35	39.06	30.12	13.6	-	-	-	49° 3'	φ35.5	520.3
M3S 20 # 5818H	1	20	φ60	(φ64.24) φ61.99	58	φ18(H8)	φ50	23	35	39.06	30.12	13.6	6 × 2.8	2-M6	11.5	49° 3'	φ35.5	498.1
M3S 20 # 5820H	1	20	φ60	(φ64.24) φ61.99	58	φ20(H8)	φ50	23	35	39.06	30.12	13.6	6 × 2.8	2-M6	11.5	49° 3'	φ35.5	481.9
M3S 20 # 5825H	1	20	φ60	(φ64.24) φ61.99	58	φ25(H8)	φ50	23	35	39.06	30.12	13.6	8 × 3.3	2-M6	11.5	49° 3'	φ35.5	431.2
M3S 20 - 4216	1	20	φ60	(φ64.24) φ61.99	42	φ16	φ50	7	19	23.06	14.12	13.6	-	-	-	49° 3'	φ35.5	298.9
M3S 20 - 4216H	1	20	φ60	(φ64.24) φ61.99	42	φ16(H8)	φ50	7	19	23.06	14.12	13.6	-	-	-	49° 3'	φ35.5	298.9
M3S 20 = 4218H	1	20	φ60	(φ64.24) φ61.99	42	φ18(H8)	φ50	7	19	23.06	14.12	13.6	6 × 2.8	-	-	49° 3'	φ35.5	288.4
M3S 20 = 4220H	1	20	φ60	(φ64.24) φ61.99	42	φ20(H8)	φ50	7	19	23.06	14.12	13.6	6 × 2.8	-	-	49° 3'	φ35.5	279.5
M3S 20 = 4225H	1	20	φ60	(φ64.24) φ61.99	42	φ25(H8)	φ50	7	19	23.06	14.12	13.6	8 × 3.3	-	-	49° 3'	φ35.5	251.7
M3S 25 - 6020	1	25	φ75	(φ79.24) φ77	60	φ20	φ65	17.5	32	35.31	24.62	16.2	-	-	-	48° 51'	φ48.1	785.6
M3S 25 - 6020H	1	25	φ75	(φ79.24) φ77	60	φ20(H8)	φ65	17.5	32	35.31	24.62	16.2	-	-	-	48° 51'	φ48.1	785.6

カタログ記号の末尾に【H】を付した商品は歯部高周波焼入済です。【H】: Gear tooth surface completed with induction hardening, Hardness HRC 47 to 53.
【#】(シャープ)にはキー材とセットスクリューが付いております。【#】: Gear with key way and threaded hole / with key and screw.

歯先円直径 da の () 内は理論値です。最大外径は軸心と平行に面取りしてありますので、理論値より小さくなっています。

The numeric indicated in the bracket () under the column. Outside diameter da has been machined flat. With this process, the outer diameter is smaller than the theory with respect to shaft center to parallel.

許容伝達動力表 (kW) 曲げ強さ

Allowable transfer capability table (kW) Bending Strength

商品記号 Catalogue Numbers	回転速度 (min ⁻¹) revolution/min						
	10	100	200	400	600	800	1,000
M3S 20 - 5816	0.029	0.297	0.594	1.148	1.591	1.971	2.323
M3S 20 - 5816H	0.027	0.275	0.551	1.068	1.489	1.854	2.184
M3S 25 - 6020	0.048	0.482	0.964	1.789	2.442	3.016	3.667
M3S 25 - 6020H	0.045	0.451	0.902	1.684	2.315	2.861	3.400

The above references are JGMA standard.

動力の換算式は P26 をご参照ください。Please refer to the conversion formulas of power on page P26.

許容伝達動力表 (kW) 歯面強さ

Allowable transfer capability table (kW) Surface Durability

商品記号 Catalogue Numbers	回転速度 (min ⁻¹) revolution/min						
	10	100	200	400	600	800	1,000
M3S 20 - 5816	0.002	0.025	0.050	0.098	0.139	0.175	0.209
M3S 20 - 5816H	0.006	0.068	0.140	0.281	0.398	0.503	0.598
M3S 25 - 6020	0.004	0.048	0.097	0.184	0.256	0.323	0.401
M3S 25 - 6020H	0.011	0.131	0.272	0.523	0.732	0.916	1.100

JIS B1704 3級 (歯部高周波焼入品:4級)
System of Accuracy: JIS B 1704 Class 3
(Induction hardened products: Class 4)



御注文には必ず“フルネームで商品記号”を明記してください。
Please refer to the catalogue reference while ordering.
 d_s の寸法は参考値です。
Dimension of d_s is for reference only.

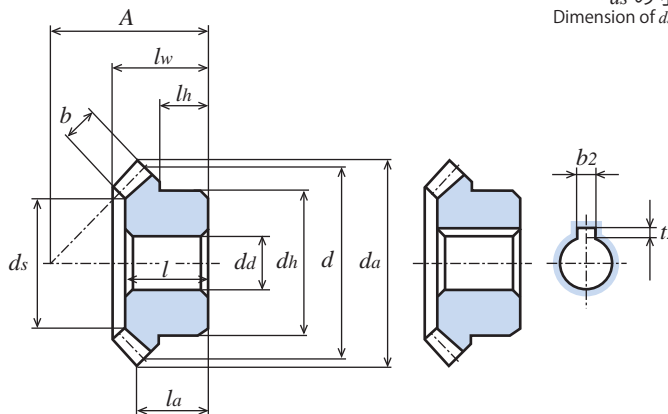

S45C 機械構造用炭素鋼 (JIS G 4051)

Material: Carbon Steel (ISO C45)

単位: mm
Dimensions: mm

商品記号 Catalogue Number	歯数比 Ratio	歯数 Number of Teeth	基準円直径 Reference Diameter	歯先円直径 Tip Diameter	組立距離 Locating Distance	穴径 Bore Diameter	ハブ外径 Hub Diameter	ハブ長さ Hub Projection	穴長さ Bore Length	全長 Overall Length	Tip Distance	歯幅 Face Width	キミぞ Key Way	ねじ Set Screw		歯先角 Face Angle	歯先角 Face Angle	重量 Weight
														2-M	ls			
M3S 30 - 7522	1	30	$\phi 90$	$\phi 92.04$ ^($\phi 94.24$)	75	$\phi 22$	$\phi 66$	23.64	40	44.65	32.12	18.6	-	-	-	47°42'	$\phi 57.3$	1.20
M3S 30 - 7522H	1	30	$\phi 90$	$\phi 92.04$ ^($\phi 94.24$)	75	$\phi 22$ (H8)	$\phi 66$	23.64	40	44.65	32.12	18.6	-	-	-	47°42'	$\phi 57.3$	1.20
M3S 30 # 7525H	1	30	$\phi 90$	$\phi 92.04$ ^($\phi 94.24$)	75	$\phi 25$ (H8)	$\phi 66$	23.64	40	44.65	32.12	18.6	8 × 3.3	2-M6	12	47°42'	$\phi 57.3$	1.16
M3S 30 # 7530H	1	30	$\phi 90$	$\phi 92.04$ ^($\phi 94.24$)	75	$\phi 30$ (H8)	$\phi 66$	23.64	40	44.65	32.12	18.6	8 × 3.3	2-M6	12	47°42'	$\phi 57.3$	1.09
M3S 30 - 6020	1	30	$\phi 90$	$\phi 92.04$ ^($\phi 94.24$)	60	$\phi 20$	$\phi 66$	8.64	25	29.65	17.12	18.6	-	-	-	47°42'	$\phi 57.3$	0.85
M3S 30 - 6020H	1	30	$\phi 90$	$\phi 92.04$ ^($\phi 94.24$)	60	$\phi 20$ (H8)	$\phi 66$	8.64	25	29.65	17.12	18.6	-	-	-	47°42'	$\phi 57.3$	0.85
M3S 30 = 6025H	1	30	$\phi 90$	$\phi 92.04$ ^($\phi 94.24$)	60	$\phi 25$ (H8)	$\phi 66$	8.64	25	29.65	17.12	18.6	8 × 3.3	-	-	47°42'	$\phi 57.3$	0.81
M3S 30 = 6030H	1	30	$\phi 90$	$\phi 92.04$ ^($\phi 94.24$)	60	$\phi 30$ (H8)	$\phi 66$	8.64	25	29.65	17.12	18.6	8 × 3.3	-	-	47°42'	$\phi 57.3$	0.74

カタログ記号の末尾に【H】を付した商品は歯部高周波焼入済です。【H】: Gear tooth surface completed with induction hardening, Hardness HRC 47 to 53.
【#】(シャープ)にはキー材とセットスクリューが付いております。【#】: Gear with key way and threaded hole / with key and screw.

	歯数比 Ratio	ピッチ角 Pitch Angle	軸角 Shaft Angle
マイタギヤ Miter gear	1:1	45°	90°
ベベルギヤ Bevel gear	1:2	ピニオン ギヤ Pinion Gear	26° 34' 63° 26'
	1:3	ピニオン ギヤ Pinion Gear	18° 26' 71° 34'

許容伝達動力表 (kW) 曲げ強さ

Allowable transfer capability table (kW) Bending Strength

商品記号 Catalogue Numbers	回転速度 (min ⁻¹) revolution/min						
	10	100	200	400	600	800	1,000
M3S 30 - 7522	0.070	0.706	1.413	2.522	3.394	4.322	5.232
M3S 30 - 7522H	0.066	0.666	1.332	2.399	3.254	4.056	4.784

The above references are JGMA standard.

動力の換算式は P26 をご参照ください。Please refer to the conversion formulas of power on page P26.

許容伝達動力表 (kW) 歯面強さ

Allowable transfer capability table (kW) Surface Durability

商品記号 Catalogue Numbers	回転速度 (min ⁻¹) revolution/min						
	10	100	200	400	600	800	1,000
M3S 30 - 7522	0.008	0.082	0.166	0.303	0.418	0.547	0.678
M3S 30 - 7522H	0.020	0.225	0.464	0.862	1.190	1.502	1.790

目次 CONTENTS

インフォメーション INFORMATION

ギヤボックス GEAR BOXES

ノーバッキングギヤ ANTI BACKLASH SPUR GEARS

歯研歯面 GROUND SPUR GEARS

平歯車 SPUR GEARS

内歯車 INTERNAL GEARS

歯研ラック GROUND RACKS

ラック RACKS

へリカル・スクリューギヤ HELICAL GEARS AND SCREW GEARS

ウォーム・ウォームギヤ WORMS AND WORM GEARS

かな歯車 BEVEL GEARS

スプロケット SPROCKETS

技術資料 REFERENCE DATA

ベベルギヤ

BEVEL GEARS

モジュール **3**
MODULE

圧力角 20° 歯数比 1:2
1:2 Ratio 20° PRESSURE ANGLE

JIS B1704 3級 (歯部高周波焼入品:4級)
System of Accuracy: JIS B 1704 Class 3
(Induction hardened products: Class 4)



仕様変更 締結加工不要。
Additional machining on tightening is not necessary.

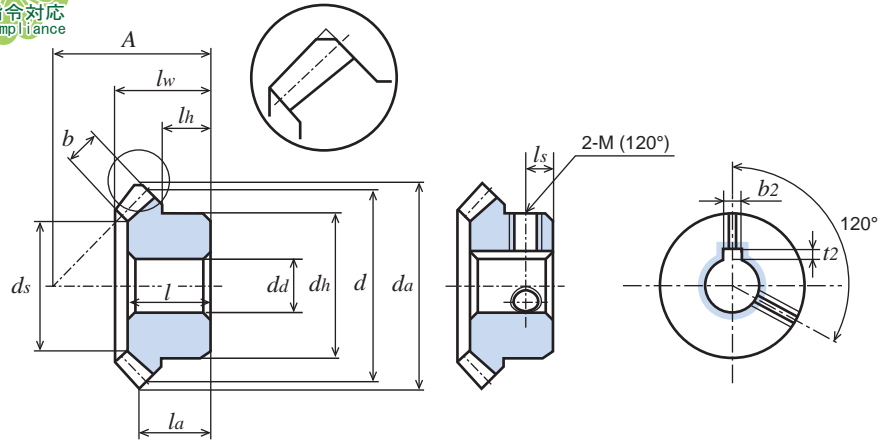

S45C 機械構造用炭素鋼 (JIS G 4051) Material: Carbon Steel (ISO C45)

単位: mm
Dimensions: mm

商品記号 Catalogue Number	歯数比 Ratio	歯数 Number of Teeth	基準円直径 Reference Diameter	歯先円直径 Tip Diameter	組立距離 Locating Distance	穴径 Bore Diameter	ハブ外径 Hub Diameter	ハブ長さ Hub Projection	穴長さ Bore Length	全長 Overall Length	Tip Distance	歯幅 Face Width	キーみぞ Key Way	ねじ Set Screw		歯先角 Face Angle	歯先角 Face Angle	重量 Weight
														2-M	ls			
B3S 18 - 15	2	18	ϕ 54	ϕ 56.72 (ϕ 59.37)	75.27	ϕ 15	ϕ 41	18	37	40.06	22.61	20	-	-	-	29°25'	ϕ 27.4	0.39
B3S 18 - 15H	2	18	ϕ 54	ϕ 56.72 (ϕ 59.37)	75.27	ϕ 15(H8)	ϕ 41	18	37	40.06	22.61	20	-	-	-	29°25'	ϕ 27.4	0.39
B3S 18 # 16H	2	18	ϕ 54	ϕ 56.72 (ϕ 59.37)	75.27	ϕ 16(H8)	ϕ 41	18	37	40.06	22.61	20	5 × 2.3	2-M6	9	29°25'	ϕ 27.4	0.38
B3S 18 # 20H	2	18	ϕ 54	ϕ 56.72 (ϕ 59.37)	75.27	ϕ 20(H8)	ϕ 41	18	37	40.06	22.61	20	6 × 2.8	2-M6	9	29°25'	ϕ 27.4	0.35
B3S 36 - 16	2	36	ϕ 108	ϕ 108.2 (ϕ 110.68)	52.32	ϕ 16	ϕ 60	19	31	36.06	28	20	-	-	-	66°17'	ϕ 68.9	1.15
B3S 36 - 16H	2	36	ϕ 108	ϕ 108.2 (ϕ 110.68)	52.32	ϕ 16(H8)	ϕ 60	19	31	36.06	28	20	-	-	-	66°17'	ϕ 68.9	1.15
B3S 36 # 25H	2	36	ϕ 108	ϕ 108.2 (ϕ 110.68)	52.32	ϕ 25(H8)	ϕ 60	19	31	36.06	28	20	8 × 3.3	2-M6	9.5	66°17'	ϕ 68.9	1.07
B3S 36 # 30H	2	36	ϕ 108	ϕ 108.2 (ϕ 110.68)	52.32	ϕ 30(H8)	ϕ 60	19	31	36.06	28	20	8 × 3.3	2-M6	9.5	66°17'	ϕ 68.9	1.02

カタログ記号の末尾に【H】を付した商品は歯部高周波焼入済です。【H】: Gear tooth surface completed with induction hardening, Hardness HRC 47 to 53.
【#】(シャープ)にはキー材とセットスクリューが付いております。【#】: Gear with key way and threaded hole / with key and screw.

歯先円直径 d_a の () 内は理論値です。最大外径は軸心と平行に面取りしてありますので、理論値より小さくなっています。

The numeric indicated in the bracket () under the column. Outside diameter d_a has been machined flat. With this process, the outer diameter is smaller than the theory with respect to shaft center to parallel.

許容伝達動力表 (kW) 曲げ強さ

Allowable transfer capability table (kW) Bending Strength

商品記号 Catalogue Numbers	回転速度 (min ⁻¹) revolution/min						
	10	100	200	400	600	800	1,000
B3S 18 - 15	0.036	0.361	0.722	1.419	1.979	2.465	2.892
B3S 18 - 15H	0.033	0.332	0.665	1.310	1.837	2.300	2.710

許容伝達動力表 (kW) 歯面強さ

Allowable transfer capability table (kW) Surface Durability

商品記号 Catalogue Numbers	回転速度 (min ⁻¹) revolution/min						
	10	100	200	400	600	800	1,000
B3S 18 - 15	0.003	0.037	0.074	0.148	0.209	0.264	0.315
B3S 18 - 15H	0.009	0.100	0.207	0.420	0.600	0.761	0.905

The above references are JGMA standard.

動力の換算式は P26 をご参照ください。Please refer to the conversion formulas of power on page P26.

JIS B1704 3級 (歯部高周波焼入品:4級)
System of Accuracy: JIS B 1704 Class 3
(Induction hardened products: Class 4)



御注文には必ず“フルネームで商品記号”を明記してください。
Please refer to the catalogue reference while ordering.
 d_s の寸法は参考値です。
Dimension of d_s is for reference only.

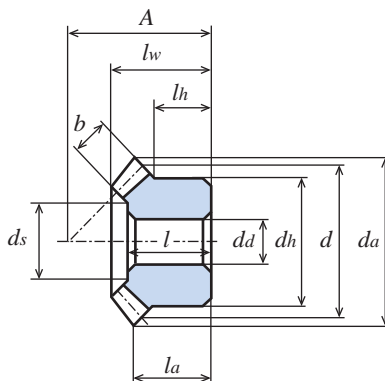

S45C 機械構造用炭素鋼 (JIS G 4051)

Material: Carbon Steel (ISO C45)

単位: mm
Dimensions: mm

商品記号 Catalogue Number	歯数比 Ratio	歯数 Number of Teeth	基準円直径 Reference Diameter	歯先円直径 Tip Diameter	組立距離 Locating Distance	穴径 Bore Diameter	ハブ外径 Hub Diameter	ハブ長さ Hub Projection	穴長さ Bore Length	全長 Overall Length	歯幅 Face Width	キーみぞ Key Way	ねじ Set Screw		歯先角 Face Angle	重量 Weight	
													2-M	ls			δ_a
B3S 15 - 12	3	15	ϕ 45	ϕ 51.29 ^(ϕ53.02)	89.36	ϕ 12(H8)	ϕ 36	20.3	42	44.53	23.2	-	-	-	22°17'	ϕ 20.3	0.34
B3S 15 - 12H	3	15	ϕ 45	ϕ 51.29 ^(ϕ53.02)	89.36	ϕ 12(H8)	ϕ 36	20.3	42	44.53	23.2	-	-	-	22°17'	ϕ 20.3	0.34
B3S 15 # 16H	3	15	ϕ 45	ϕ 51.29 ^(ϕ53.02)	89.36	ϕ 16(H8)	ϕ 36	20.3	42	44.53	23.2	5 × 2.3	2-M6	10.5	22°17'	ϕ 20.3	0.31
B3S 45 - 18	3	45	ϕ 135	ϕ 133.9 ^(ϕ136.12)	50.95	ϕ 18	ϕ 70	19	32	36.69	30.13	-	-	-	73°27'	ϕ 88.8	1.95
B3S 45 - 18H	3	45	ϕ 135	ϕ 133.9 ^(ϕ136.12)	50.95	ϕ 18(H8)	ϕ 70	19	32	36.69	30.13	-	-	-	73°27'	ϕ 88.8	1.95
B3S 45 # 25H	3	45	ϕ 135	ϕ 133.9 ^(ϕ136.12)	50.95	ϕ 25(H8)	ϕ 70	19	32	36.69	30.13	8 × 3.3	2-M6	9.5	73°27'	ϕ 88.8	1.89
B3S 45 # 30H	3	45	ϕ 135	ϕ 133.9 ^(ϕ136.12)	50.95	ϕ 30(H8)	ϕ 70	19	32	36.69	30.13	8 × 3.3	2-M6	9.5	73°27'	ϕ 88.8	1.83

カタログ記号の末尾に【H】を付した商品は歯部高周波焼入済です。[H]: Gear tooth surface completed with induction hardening, Hardness HRC 47 to 53.
【#】(シャープ)にはキー材とセットスクリューが付いております。[#]: Gear with key way and threaded hole / with key and screw.

	歯数比	ピッチ角		軸角
	Ratio	Pitch Angle		Shaft Angle
マイタギヤ Miter gear	1:1	45°		90°
ベベルギヤ Bevel gear	1:2	ピニオン ギヤ Pinion Gear	26° 34' 63° 26'	90°
	1:3	ピニオン ギヤ Pinion Gear	18° 26' 71° 34'	90°

許容伝達動力表 (kW) 曲げ強さ

Allowable transfer capability table (kW) Bending Strength

商品記号 Catalogue Numbers	回転速度 (min ⁻¹) revolution/min						
	10	100	200	400	600	800	1,000
B3S 15 - 12	0.034	0.343	0.686	1.373	1.950	2.451	2.898
B3S 15 - 12H	0.031	0.317	0.635	1.271	1.814	2.290	2.718

The above references are JGMA standard.

動力の換算式は P26 をご参照ください。Please refer to the conversion formulas of power on page P26.

許容伝達動力表 (kW) 歯面強さ

Allowable transfer capability table (kW) Surface Durability

商品記号 Catalogue Numbers	回転速度 (min ⁻¹) revolution/min						
	10	100	200	400	600	800	1,000
B3S 15 - 12	0.003	0.030	0.062	0.125	0.180	0.228	0.274
B3S 15 - 12H	0.007	0.084	0.174	0.359	0.522	0.667	0.800

- 目次 CONTENTS
- インフォメーション INFORMATION
- ギヤボックス GEAR BOXES
- ノーバッキングバックラッシュギヤ ANTI BACKLASH SPUR GEARS
- 歯研削歯車 GROUND SPUR GEARS
- 平歯車 SPUR GEARS
- 内歯車 INTERNAL GEARS
- 歯研削ラック GROUND RACKS
- ラック RACKS
- へリカル・スクリューギヤ HELICAL GEARS AND SCREW GEARS
- ワーム・ワームホイール WORMS AND WORM WHEELS
- かな歯車 BEVEL GEARS
- スプロケット SPROCKETS
- 技術資料 REFERENCE DATA

マイタギヤ

MITER GEARS

モジュール 4

MODULE

圧力角 20° 歯数比 1:1
1:1 Ratio 20° PRESSURE ANGLE

JIS B1704 3級 (歯部高周波焼入品:4級)
System of Accuracy: JIS B 1704 Class 3
(Induction hardened products: Class 4)



New 仕様変更 締結加工不要。
Additional machining on tightening is not necessary.

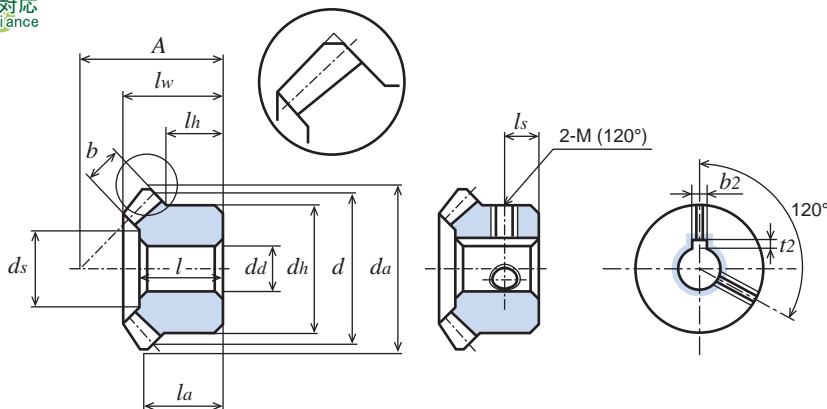

S45C 機械構造用炭素鋼 (JIS G 4051)

Material: Carbon Steel (ISO C45)

単位: mm
Dimensions: mm

商品記号 Catalogue Number	歯数比 Ratio	歯数 Number of Teeth	基準円直径 Reference Diameter	歯先円直径 Tip Diameter	組立距離 Locating Distance	穴径 Bore Diameter	ハブ外径 Hub Diameter	ハブ長さ Hub Projection	穴長さ Bore Length	全長 Overall Length	歯幅 Face Width	ねじ Set Screw	歯先角 Face Angle	重量 Weight				
															キーみぞ Key Way	ねじ Set Screw	歯先角 Face Angle	
			d	d_a	A	$d_d(H7)$	d_h	l_h	l	l_w	l_a	b	$b_2 \times t_2$	$2-M$	l_s	δ_a	d_s	$W(kg)$
M4S 20-7520	1	20	$\phi 80$	$\phi 82.65$ <small>($\phi 85.66$)</small>	75	$\phi 20$	$\phi 64$	27	45	50.05	37.83	18.6	-	-	-	49° 3'	$\phi 47.3$	1.14
M4S 20-7520H	1	20	$\phi 80$	$\phi 82.65$ <small>($\phi 85.66$)</small>	75	$\phi 20(H8)$	$\phi 64$	27	45	50.05	37.83	18.6	-	-	-	49° 3'	$\phi 47.3$	1.14
M4S 20 # 7525H	1	20	$\phi 80$	$\phi 82.65$ <small>($\phi 85.66$)</small>	75	$\phi 25(H8)$	$\phi 64$	27	45	50.05	37.83	18.6	8 × 3.3	2-M8	13.5	49° 3'	$\phi 47.3$	1.06
M4S 20 # 7530H	1	20	$\phi 80$	$\phi 82.65$ <small>($\phi 85.66$)</small>	75	$\phi 30(H8)$	$\phi 64$	27	45	50.05	37.83	18.6	8 × 3.3	2-M8	13.5	49° 3'	$\phi 47.3$	0.98

カタログ記号の末尾に【H】を付した商品は歯部高周波焼入済です。【H】: Gear tooth surface completed with induction hardening, Hardness HRC 47 to 53.
【#】(シャープ)にはキー材とセットスクリーが付いております。【#】: Gear with key way and threaded hole / with key and screw.

許容伝達動力表 (kW) 曲げ強さ

Allowable transfer capability table (kW) Bending Strength

商品記号 Catalogue Numbers	回転速度 (min ⁻¹) revolution/min						
	10	100	200	400	600	800	1,000
M4S 20-7520	0.071	0.719	1.438	2.634	3.577	4.465	5.421
M4S 20-7520H	0.066	0.663	1.327	2.448	3.349	4.150	4.920

The above references are JGMA standard.

動力の換算式は P26 をご参照ください。Please refer to the conversion formulas of power on page P26.

許容伝達動力表 (kW) 歯面強さ

Allowable transfer capability table (kW) Surface Durability

商品記号 Catalogue Numbers	回転速度 (min ⁻¹) revolution/min						
	10	100	200	400	600	800	1,000
M4S 20-7520	0.006	0.062	0.126	0.236	0.327	0.418	0.516
M4S 20-7520H	0.015	0.168	0.347	0.660	0.920	1.154	1.382

JIS B1704 3級 (歯部高周波焼入品:4級)
System of Accuracy: JIS B 1704 Class 3
(Induction hardened products: Class 4)



御注文には必ず“フルネームで商品記号”を明記してください。
Please refer to the catalogue reference while ordering.
 d_s の寸法は参考値です。
Dimension of d_s is for reference only.

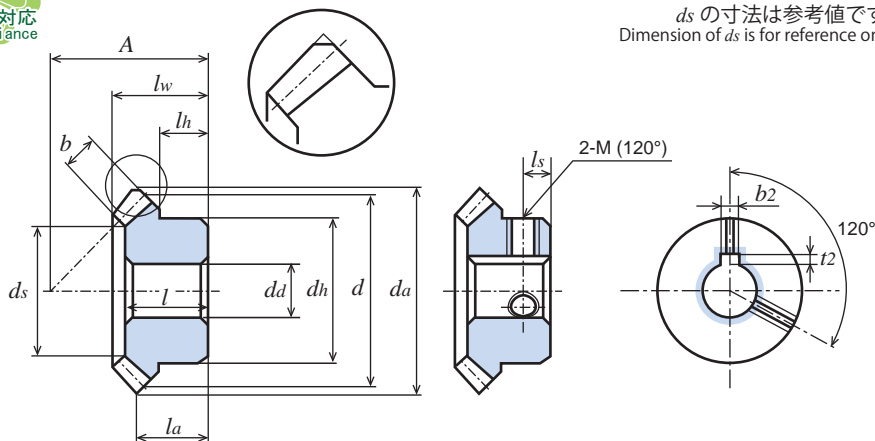

S45C 機械構造用炭素鋼 (JIS G 4051)

Material: Carbon Steel (ISO C45)

単位: mm
Dimensions: mm

商品記号 Catalogue Number	歯数比 Ratio	歯数 Number of Teeth	基準円直径 Reference Diameter	歯先円直径 Tip Diameter	組立距離 Locating Distance	穴径 Bore Diameter	ハブ外径 Hub Diameter	ハブ長さ Hub Projection	穴長さ Bore Length	全長 Overall Length	Tip Distance	歯幅 Face Width	キミぞ Key Way	ねじ Set Screw		歯先角 Face Angle		重量 Weight
														2-M	ls	δ_a	d_s	
B4S 18 - 20	2	18	$\phi 72$	$\phi 75.63$ <small>($\phi 79.16$)</small>	99.73	$\phi 20$	$\phi 55$	23.5	48	52.02	29.52	25.8	-	-	-	29°25'	$\phi 37.6$	0.94
B4S 18 - 20H	2	18	$\phi 72$	$\phi 75.63$ <small>($\phi 79.16$)</small>	99.73	$\phi 20(H8)$	$\phi 55$	23.5	48	52.02	29.52	25.8	-	-	-	29°25'	$\phi 37.6$	0.94
B4S 18 # 20H	2	18	$\phi 72$	$\phi 75.63$ <small>($\phi 79.16$)</small>	99.73	$\phi 20(H8)$	$\phi 55$	23.5	48	52.02	29.52	25.8	6 × 2.8	2-M8	12	29°25'	$\phi 37.6$	0.92
B4S 18 # 25H	2	18	$\phi 72$	$\phi 75.63$ <small>($\phi 79.16$)</small>	99.73	$\phi 25(H8)$	$\phi 55$	23.5	48	52.02	29.52	25.8	8 × 3.3	2-M8	12	29°25'	$\phi 37.6$	0.86
B4S 36 - 22	2	36	$\phi 144$	$\phi 144.3$ <small>($\phi 147.58$)</small>	71.56	$\phi 22$	$\phi 75$	23	42	49.53	39.14	25.8	-	-	-	66°17'	$\phi 92.7$	2.89
B4S 36 - 22H	2	36	$\phi 144$	$\phi 144.3$ <small>($\phi 147.58$)</small>	71.56	$\phi 22(H8)$	$\phi 75$	23	42	49.53	39.14	25.8	-	-	-	66°17'	$\phi 92.7$	2.89
B4S 36 # 30H	2	36	$\phi 144$	$\phi 144.3$ <small>($\phi 147.58$)</small>	71.56	$\phi 30(H8)$	$\phi 75$	23	42	49.53	39.14	25.8	8 × 3.3	2-M8	11.5	66°17'	$\phi 92.7$	2.77
B4S 36 # 40H	2	36	$\phi 144$	$\phi 144.3$ <small>($\phi 147.58$)</small>	71.56	$\phi 40(H8)$	$\phi 75$	23	42	49.53	39.14	25.8	12 × 3.3	2-M10	11.5	66°17'	$\phi 92.7$	2.58

カタログ記号の末尾に【H】を付した商品は歯部高周波焼入済です。【H】: Gear tooth surface completed with induction hardening, Hardness HRC 47 to 53.
【#】(シャープ)にはキー材とセットスクリューが付いております。【#】: Gear with key way and threaded hole / with key and screw.

許容伝達動力表 (kW) 曲げ強さ

Allowable transfer capability table (kW) Bending Strength

商品記号 Catalogue Numbers	回転速度 (min ⁻¹) revolution/min						
	10	100	200	400	600	800	1,000
B4S 18 - 20	0.083	0.833	1.667	3.118	4.268	5.237	6.375
B4S 18 - 20H	0.077	0.773	1.546	2.908	4.007	4.943	5.883

The above references are JGMA standard.

動力の換算式は P26 をご参照ください。Please refer to the conversion formulas of power on page P26.

許容伝達動力表 (kW) 歯面強さ

Allowable transfer capability table (kW) Surface Durability

商品記号 Catalogue Numbers	回転速度 (min ⁻¹) revolution/min						
	10	100	200	400	600	800	1,000
B4S 18 - 20	0.008	0.088	0.178	0.339	0.473	0.592	0.736
B4S 18 - 20H	0.021	0.239	0.494	0.958	1.344	1.679	2.018

JIS B1704 3級 (歯部高周波焼入品:4級)
System of Accuracy: JIS B 1704 Class 3
(Induction hardened products: Class 4)



仕様変更 締結加工不要。
Additional machining on tightening is not necessary.

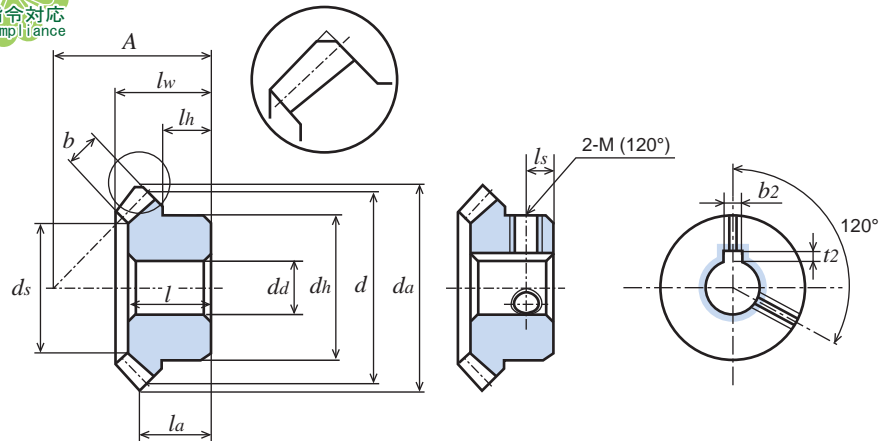

S45C 機械構造用炭素鋼 (JIS G 4051)

Material: Carbon Steel (ISO C45)

単位: mm
Dimensions: mm

商品記号 Catalogue Number	歯数比 Ratio	歯数 Number of Teeth	基準円直径 Reference Diameter	歯先円直径 Tip Diameter	組立距離 Locating Distance	穴径 Bore Diameter	ハブ外径 Hub Diameter	ハブ長さ Hub Projection	穴長さ Bore Length	全長 Overall Length	歯幅 Face Width	キーみぞ Key Way	ねじ Set Screw		歯先角 Face Angle	重量 Weight		
													2-M	ls			δa	ds
B4S 15 - 16	3	15	φ 60	φ 68.38 ^(φ70.69)	119.14	φ16(H8)	φ52	27.8	57	59.67	30.92	31	-	-	22°17'	φ 31.1	0.85	
B4S 15 - 16H	3	15	φ 60	φ 68.38 ^(φ70.69)	119.14	φ16(H8)	φ52	27.8	57	59.67	30.92	31	-	-	22°17'	φ 31.1	0.85	
B4S 15 # 20H	3	15	φ 60	φ 68.38 ^(φ70.69)	119.14	φ20(H8)	φ52	27.8	57	59.67	30.92	31	6 × 2.8	2-M8	14	22°17'	φ 31.1	0.78
B4S 45 - 25	3	45	φ180	φ178.6 ^(φ181.5)	65.47	φ25	φ80	22	40	46.55	37.71	31	-	-	73°27'	φ117.6	4.28	
B4S 45 - 25H	3	45	φ180	φ178.6 ^(φ181.5)	65.47	φ25(H8)	φ80	22	40	46.55	37.71	31	-	-	73°27'	φ117.6	4.28	
B4S 45 # 30H	3	45	φ180	φ178.6 ^(φ181.5)	65.47	φ30(H8)	φ80	22	40	46.55	37.71	31	8 × 3.3	2-M8	11	73°27'	φ117.6	4.19
B4S 45 # 40H	3	45	φ180	φ178.6 ^(φ181.5)	65.47	φ40(H8)	φ80	22	40	46.55	37.71	31	12 × 3.3	2-M10	11	73°27'	φ117.6	4.02

カタログ記号の末尾に【H】を付した商品は歯部高周波焼入済です。【H】: Gear tooth surface completed with induction hardening, Hardness HRC 47 to 53.
【#】(シャープ)にはキー材とセットスクリューが付いております。【#】: Gear with key way and threaded hole / with key and screw.

歯先円直径 da の () 内は理論値です。最大外径は軸心と平行に面取りしてありますので、理論値より小さくなっています。

The numeric indicated in the bracket () under the column. Outside diameter da has been machined flat. With this process, the outer diameter is smaller than the theory with respect to shaft center to parallel.

許容伝達動力表 (kW) 曲げ強さ

Allowable transfer capability table (kW) Bending Strength

商品記号 Catalogue Numbers	回転速度 (min ⁻¹) revolution/min						
	10	100	200	400	600	800	1,000
B4S 15 - 16	0.082	0.821	1.642	3.173	4.396	5.445	6.420
B4S 15 - 16H	0.075	0.758	1.517	2.940	4.099	5.104	6.013

The above references are JGMA standard.

動力の換算式は P26 をご参照ください。Please refer to the conversion formulas of power on page P26.

許容伝達動力表 (kW) 歯面強さ

Allowable transfer capability table (kW) Surface Durability

商品記号 Catalogue Numbers	回転速度 (min ⁻¹) revolution/min						
	10	100	200	400	600	800	1,000
B4S 15 - 16	0.007	0.076	0.153	0.301	0.423	0.533	0.639
B4S 15 - 16H	0.018	0.207	0.427	0.853	1.210	1.526	1.816

JIS B1704 3級 (歯部高周波焼入品:4級)
System of Accuracy: JIS B 1704 Class 3
(Induction hardened products: Class 4)



御注文には必ず“フルネームで商品記号”を明記してください。
Please refer to the catalogue reference while ordering.
 d_s の寸法は参考値です。
Dimension of d_s is for reference only.

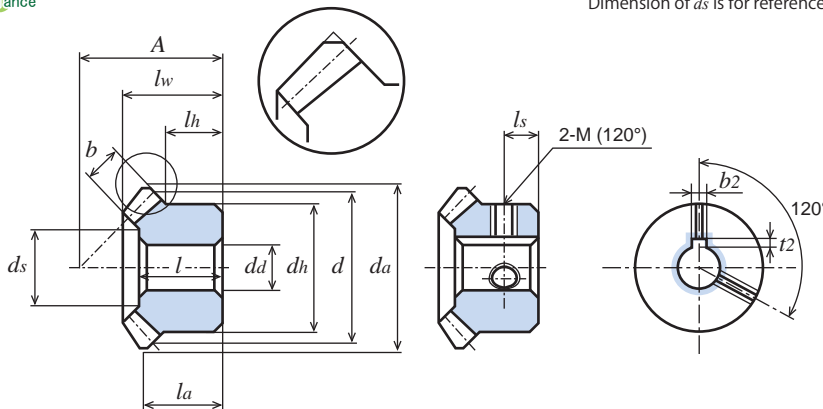

S45C 機械構造用炭素鋼 (JIS G 4051)

Material: Carbon Steel (ISO C45)

単位: mm
Dimensions: mm

商品記号 Catalogue Number	歯数比 Ratio u	歯数 Number of Teeth z	基準円直径 Reference Diameter d	歯先円直径 Tip Diameter d_a	組立距離 Locating Distance A	穴径 Bore Diameter $d_a(H7)$	ハブ外径 Hub Diameter d_h	ハブ長さ Hub Projection l_h	穴長さ Bore Length l	全長 Overall Length l_w	全長 Overall Length l_a	歯幅 Face Width b	キミぞ Key Way $b_2 \times t_2$	ねじ Set Screw		歯先角 Face Angle		重量 Weight $W(kg)$
														2-M	l_s	δ_a	d_s	
M5S 20 - 9025	1	20	$\phi 100$	$\phi 103.3$ <small>($\phi 107.07$)</small>	90	$\phi 25$	$\phi 80$	30	53	59.04	43.54	23.6	-	-	-	49° 3'	$\phi 59.2$	2.11
M5S 20 - 9025H	1	20	$\phi 100$	$\phi 103.3$ <small>($\phi 107.07$)</small>	90	$\phi 25(H8)$	$\phi 80$	30	53	59.04	43.54	23.6	-	-	-	49° 3'	$\phi 59.2$	2.11
M5S 20 # 9030H	1	20	$\phi 100$	$\phi 103.3$ <small>($\phi 107.07$)</small>	90	$\phi 30(H8)$	$\phi 80$	30	53	59.04	43.54	23.6	8 × 3.3	2-M10	15	49° 3'	$\phi 59.2$	2.00
M5S 20 # 9040H	1	20	$\phi 100$	$\phi 103.3$ <small>($\phi 107.07$)</small>	90	$\phi 40(H8)$	$\phi 80$	30	53	59.04	43.54	23.6	12 × 3.3	2-M10	15	49° 3'	$\phi 59.2$	1.76

カタログ記号の末尾に【H】を付した商品は歯部高周波焼入済です。【H】: Gear tooth surface completed with induction hardening, Hardness HRC 47 to 53.
【#】(シャープ)にはキー材とセットスクリーンが付いております。【#】: Gear with key way and threaded hole / with key and screw.

許容伝達動力表 (kW) 曲げ強さ

Allowable transfer capability table (kW) Bending Strength

商品記号 Catalogue Numbers	回転速度 (min ⁻¹) revolution/min						
	10	100	200	400	600	800	1,000
M5S 20 - 9025	0.142	1.421	2.825	4.949	6.669	8.574	10.318
M5S 20 - 9025H	0.130	1.308	2.601	4.603	6.220	7.758	-

The above references are JGMA standard.

動力の換算式は P26 をご参照ください。Please refer to the conversion formulas of power on page P26.

許容伝達動力表 (kW) 歯面強さ

Allowable transfer capability table (kW) Surface Durability

商品記号 Catalogue Numbers	回転速度 (min ⁻¹) revolution/min						
	10	100	200	400	600	800	1,000
M5S 20 - 9025	0.012	0.127	0.255	0.458	0.635	0.836	1.040
M5S 20 - 9025H	0.030	0.338	0.694	1.267	1.743	2.201	-

JIS B1704 3級 (歯部高周波焼入品:4級)
System of Accuracy: JIS B 1704 Class 3
(Induction hardened products: Class 4)



New 仕様変更 締結加工不要。
Additional machining on tightening is not necessary.

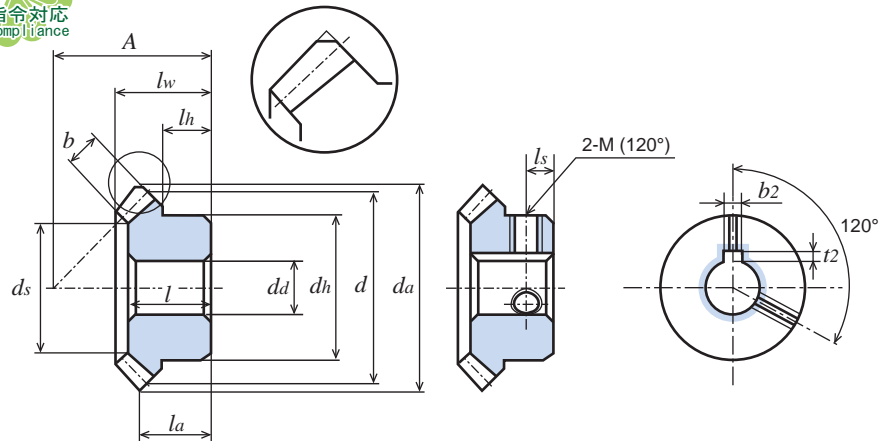

S45C 機械構造用炭素鋼 (JIS G 4051)

Material: Carbon Steel (ISO C45)

単位: mm
Dimensions: mm

商品記号 Catalogue Number	歯数比 Ratio	歯数 Number of Teeth	基準円直径 Reference Diameter	歯先円直径 Tip Diameter	組立距離 Locating Distance	穴径 Bore Diameter	ハブ外径 Hub Diameter	ハブ長さ Hub Projection	穴長さ Bore Length	全長 Overall Length	Tip Distance	歯幅 Face Width	キミぞ Key Way	ねじ Set Screw		歯先角 Face Angle	重量 Weight	
														2-M	ls			δa
B5S 18 - 22	2	18	φ 90	^(φ98.94) φ 94.54	122	φ22	φ 66	26	58	61.89	34.24	31.7	-	-	-	29°25'	φ 52.2	1.72
B5S 18 - 22H	2	18	φ 90	^(φ98.94) φ 94.54	122	φ22(H8)	φ 66	26	58	61.89	34.24	31.7	-	-	-	29°25'	φ 52.2	1.72
B5S 18 # 25H	2	18	φ 90	^(φ98.94) φ 94.54	122	φ25(H8)	φ 66	26	58	61.89	34.24	31.7	8 × 3.3	2-M10	13	29°25'	φ 52.2	1.65
B5S 18 # 30H	2	18	φ 90	^(φ98.94) φ 94.54	122	φ30(H8)	φ 66	26	58	61.89	34.24	31.7	8 × 3.3	2-M10	13	29°25'	φ 52.2	1.55
B5S 36 - 28	2	36	φ 180	^(φ184.47) φ 180.4	86.23	φ28	φ100	28	49	58.47	45.70	31.7	-	-	-	66°17'	φ116.8	5.38
B5S 36 - 28H	2	36	φ 180	^(φ184.47) φ 180.4	86.23	φ28(H8)	φ100	28	49	58.47	45.70	31.7	-	-	-	66°17'	φ116.8	5.38
B5S 36 # 40H	2	36	φ 180	^(φ184.47) φ 180.4	86.23	φ40(H8)	φ100	28	49	58.47	45.70	31.7	12 × 3.3	2-M10	14	66°17'	φ116.8	5.11
B5S 36 # 50H	2	36	φ 180	^(φ184.47) φ 180.4	86.23	φ50(H8)	φ100	28	49	58.47	45.70	31.7	14 × 3.8	2-M10	14	66°17'	φ116.8	4.83

カタログ記号の末尾に【H】を付した商品は歯部高周波焼入済です。【H】: Gear tooth surface completed with induction hardening, Hardness HRC 47 to 53.
【#】(シャープ)にはキー材とセットスクリューが付いております。【#】: Gear with key way and threaded hole / with key and screw.

許容伝達動力表 (kW) 曲げ強さ

Allowable transfer capability table (kW) Bending Strength

商品記号 Catalogue Numbers	回転速度 (min ⁻¹) revolution/min						
	10	100	200	400	600	800	1,000
B5S 18 - 22	0.160	1.605	3.211	5.731	7.712	9.822	11.888
B5S 18 - 22H	0.149	1.493	2.987	5.380	7.297	9.094	10.727

許容伝達動力表 (kW) 歯面強さ

Allowable transfer capability table (kW) Surface Durability

商品記号 Catalogue Numbers	回転速度 (min ⁻¹) revolution/min						
	10	100	200	400	600	800	1,000
B5S 18 - 22	0.017	0.175	0.353	0.644	0.889	1.162	1.440
B5S 18 - 22H	0.042	0.472	0.974	1.809	2.497	3.152	3.754

The above references are JGMA standard.

動力の換算式は P26 をご参照ください。Please refer to the conversion formulas of power on page P26.



スプロケット

Sprockets

商品記号の読み方 Reference of Catalogue Number

スプロケット

SW 37 B 10 + B
SW 48 D 20 - B
SW 1/4 S 30 - B

歯車の種類 Kind of Gear	ピッチ Pitch	材質 Material	歯数 Number of Teeth	穴仕上 Bores Processed	形状 Type
(スプロケット) Sprockets	37 : P3.75mm ラダーチェーン用 P = 3.75mm for Ladder chain. 48 : P4.8mm ラダーチェーン用 P = 4.8mm for Ladder chain. 1/4 : P6.35 プッシュチェーン用 P = 6.35mm for Bushed chain.	B : 黄銅 Brass S : S45C Carbon Steel D : ポリアセタール Poly Acetal (Machined) SU : ステンレス (SUS304) Stainless Steel	z : 8 ~ 48	【-】: 旋削加工 Machined bore. Without threaded hole. 【+】: 旋削加工 止めねじ付 Gear with threaded hole / with set screw.	A : ハブ無し Hubless. B : 片ハブ付き with Hub on one side.

Memo

目次
CONTENTS

インフォメーション
INFORMATION

ギヤボックス
GEAR BOXES

ノーバックラッシュギヤ
ANTI BACKLASH SPUR GEARS

歯研平歯車
GROUND SPUR GEARS

平歯車
SPUR GEARS

内歯車
INTERNAL GEARS

歯研ラック
GROUND RACKS

ラック
RACKS

ヘリカル・スクリューギヤ
HELICAL GEARS AND SCREW GEARS

ウォーム・ウォームホイール
WORMS AND WORM WHEELS

かさ歯車
BEVEL GEARS

スプロケット
SPURKETS

技術資料
REFERENCE DATA

ラダーチェーン用スプロケット

SPROCKETS for LADDER CHAIN

ピッチ PITCH **3.75**

ピッチ 3.75mm
SUS304 ステンレス鋼線材 (JIS G 4308)
Ladder Chain : 3.75 Pitch : Stainless

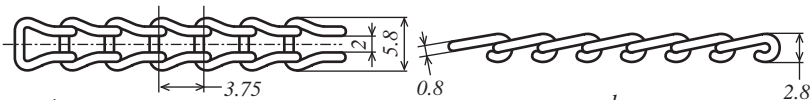

ラダーチェーンの寸法
Dimensions for Ladder chain

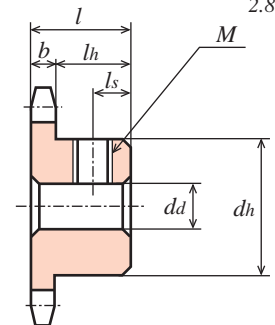

B1形
TYPE B1

C3604B 快削黄銅棒

Material : Brass (ISO CuZn39Pb3)

単位 : mm
Dimensions : mm

商品記号 Catalogue Number	歯数 Number of Teeth <i>z</i>	基準円直径 Reference Diameter <i>d</i>	外径 Outside Diameter <i>da</i>	歯底円直径 Root Diameter <i>df</i>	形 Type	歯幅 Face Width <i>b</i>	穴径 Bore Diameter <i>da(H8)</i>	ハブ外径 Hub Diameter <i>dh</i>	ハブ長さ Hub Projection <i>lh</i>	全長 Overall Length <i>l</i>	ねじ Set Screw		重量 Weight <i>W(g)</i>
											<i>M</i>	<i>ls</i>	
SW37B 10 + B	10	φ12.12	φ13.8	φ11.32	B1	1.6	φ3	φ9	8	9.6	M3	4	5.2
SW37B 11 + B	11	φ13.3	φ15	φ12.5	B1	1.6	φ3	φ9.5	8	9.6	M3	4	6.1
SW37B 12 + B	12	φ14.48	φ16.2	φ13.68	B1	1.6	φ3	φ10	8	9.6	M3	4	6.9
SW37B 13 + B	13	φ15.66	φ17.5	φ14.86	B1	1.6	φ3	φ11	8	9.6	M3	4	8.5
SW37B 14 + B	14	φ16.84	φ18.7	φ16.04	B1	1.6	φ4	φ12	8	9.6	M3	4	9.6
SW37B 15 + B	15	φ18.02	φ19.9	φ17.22	B1	1.6	φ4	φ14	8	9.6	M3	4	12.9
SW37B 16 + B	16	φ19.2	φ21.1	φ18.4	B1	1.6	φ4	φ14	8	9.6	M3	4	13.3
SW37B 18 + B	18	φ21.58	φ23.5	φ20.78	B1	1.6	φ4	φ16	8	9.6	M3	4	17.5
SW37B 20 + B	20	φ23.95	φ25.8	φ23.15	B1	1.6	φ5	φ18	10	11.6	M3	5	25.7
SW37B 22 + B	22	φ26.33	φ28.3	φ25.53	B1	1.6	φ5	φ20	10	11.6	M3	5	32.0
SW37B 24 + B	24	φ28.7	φ30.6	φ27.9	B1	1.6	φ5	φ20	10	11.6	M3	5	33.5
SW37B 26 + B	26	φ31.08	φ33	φ30.28	B1	1.6	φ6	φ20	10	11.6	M3	5	34.2
SW37B 28 + B	28	φ33.46	φ35.3	φ32.66	B1	1.6	φ6	φ20	10	11.6	M3	5	36.0
SW37B 30 + B	30	φ35.84	φ37.7	φ35.04	B1	1.6	φ6	φ20	10	11.6	M3	5	37.6

【+】にはセットスクリーンが付いております。

【+】: Gear with threaded hole / with set screw.

RoHS 対応

2006年11月生産開始分より欧州 RoHS 指令に対応できる商品を提供しています。

We supplied the KG-products with RoHS compliance of EU to all our valued customers since November 2006

目次 CONTENTS

インフォメーション INFORMATION

ギヤボックス GEAR BOXES

ノーバッキングギヤ ANTI BACKLASH SPUR GEARS

歯研削歯車 GROUND SPUR GEARS

平歯車 SPUR GEARS

内歯車 INTERNAL GEARS

歯研削ラック GROUND RACKS

ラック RACKS

（リカバ）スクリューギヤ HELICAL GEARS AND SCREW GEARS

ワームとワームホイール WORMS AND WORM WHEELS

かさ歯車 BEVEL GEARS

スプロケット SPROCKETS

技術データ REFERENCE DATA

ラダーチェーン用スプロケット

SPROCKETS for LADDER CHAIN

ピッチ 4.8
PITCH 4.8

ピッチ 4.8mm SWP (硬鋼線)
Ladder Chain : 4.8 Pitch : Stainless
: Piano Wire

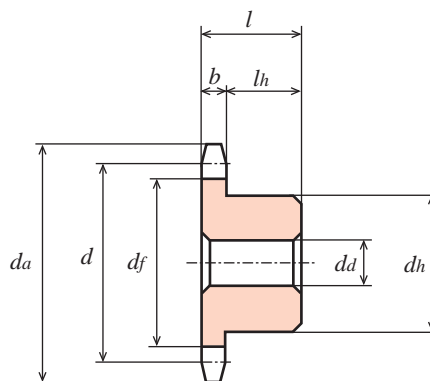

B1形
TYPE B1

ポリアセタール (白色)

Material : Poly Acetal (White)

単位 : mm
Dimensions : mm

商品記号 Catalogue Number	歯数 Number of Teeth <i>z</i>	基準円直径 Reference Diameter <i>d</i>	外径 Outside Diameter <i>da</i>	歯底円直径 Root Diameter <i>df</i>	形 Type	歯幅 Face Width <i>b</i>	穴径 Bore Diameter <i>da(H8)</i>	ハブ外径 Hub Diameter <i>dh</i>	ハブ長さ Hub Projection <i>lh</i>	全長 Overall Length <i>l</i>	重量 Weight <i>W(g)</i>
SW48D 10 - B	10	φ15.5	φ17.7	φ14.5	B1	2	φ6	φ11.5	8	10	1.3
SW48D 11 - B	11	φ17	φ19.2	φ16	B1	2	φ6	φ13	8	10	1.8
SW48D 12 - B	12	φ18.5	φ20.8	φ17.5	B1	2	φ6	φ14	8	10	2.3
SW48D 13 - B	13	φ20.1	φ22.4	φ19.1	B1	2	φ6	φ15	8	10	2.5
SW48D 14 - B	14	φ21.6	φ23.9	φ20.6	B1	2	φ6	φ17	8	10	3.2
SW48D 15 - B	15	φ23.1	φ25.5	φ22.1	B1	2	φ6	φ18	8	10	3.7
SW48D 16 - B	16	φ24.6	φ27	φ23.6	B1	2	φ6	φ19	8	10	4.2
SW48D 18 - B	18	φ27.6	φ30.1	φ26.6	B1	2	φ6	φ21	8	10	5.2
SW48D 20 - B	20	φ30.7	φ33.2	φ29.7	B1	2	φ6	φ23	8	10	6.4
SW48D 22 - B	22	φ33.7	φ36.3	φ32.7	B1	2	φ6	φ25	8	10	7.8
SW48D 24 - B	24	φ36.8	φ39.3	φ35.8	B1	2	φ6	φ25	8	10	8.3
SW48D 26 - B	26	φ39.8	φ42.4	φ38.8	B1	2	φ6	φ25	8	10	8.8
SW48D 28 - B	28	φ42.9	φ45.5	φ41.9	B1	2	φ6	φ25	8	10	9.5
SW48D 30 - B	30	φ45.9	φ48.5	φ44.9	B1	2	φ6	φ25	8	10	10.0

ラダーチェーン用スプロケット

SPROCKETS for LADDER CHAIN

ピッチ PITCH **4.8**

ピッチ 4.8mm SWP (硬鋼線)
Ladder Chain : 4.8 Pitch : Stainless
: Piano Wire



御注文には必ず“フルネームで商品記号”を明記してください。
Please refer to the catalogue reference while ordering.

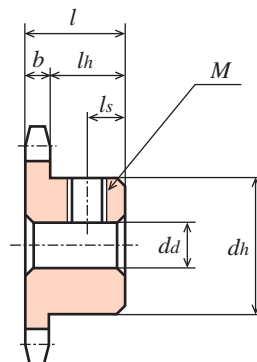

B1形
TYPE B1

C3604B 快削黄銅棒

Material : Brass (ISO CuZn39Pb3)

単位 : mm
Dimensions : mm

商品記号 Catalogue Number	歯数 Number of Teeth <i>z</i>	基準円直径 Reference Diameter <i>d</i>	外径 Outside Diameter <i>da</i>	歯底円直径 Root Diameter <i>df</i>	形 Type	歯幅 Face Width <i>b</i>	穴径 Bore Diameter <i>da</i> (H8)	ハブ 外径 Hub Diameter <i>dh</i>	ハブ 長さ Hub Projection <i>lh</i>	全長 Overall Length <i>l</i>	ねじ Set Screw		重量 Weight <i>W</i> (g)
											<i>M</i>	<i>ls</i>	
SW48B 10 + B - 4	10	φ15.5	φ17.7	φ14.5	B1	2	φ4	φ11.5	8	10	M3	4	9.3
SW48B 10 + B - 5	10	φ15.5	φ17.7	φ14.5	B1	2	φ5	φ11.5	8	10	M3	4	8.7
SW48B 10 + B	10	φ15.5	φ17.7	φ14.5	B1	2	φ6	φ11.5	8	10	M4	4	8.0
SW48B 11 + B	11	φ17	φ19.2	φ16	B1	2	φ6	φ13	8	10	M4	4	10.6
SW48B 12 + B	12	φ18.5	φ20.8	φ17.5	B1	2	φ6	φ14	8	10	M4	4	12.7
SW48B 13 + B	13	φ20.1	φ22.4	φ19.1	B1	2	φ6	φ15	8	10	M4	4	15.2
SW48B 14 + B	14	φ21.6	φ23.9	φ20.6	B1	2	φ6	φ17	8	10	M4	4	19.3
SW48B 15 + B	15	φ23.1	φ25.5	φ22.1	B1	2	φ6	φ18	8	10	M4	4	22.1
SW48B 16 + B	16	φ24.6	φ27	φ23.6	B1	2	φ6	φ19	8	10	M4	4	25.5
SW48B 18 + B	18	φ27.6	φ30.1	φ26.6	B1	2	φ6	φ21	8	10	M4	4	31.7
SW48B 20 + B	20	φ30.7	φ33.2	φ29.7	B1	2	φ6	φ23	8	10	M4	4	38.4
SW48B 22 + B	22	φ33.7	φ36.3	φ32.7	B1	2	φ6	φ25	8	10	M4	4	46.3
SW48B 24 + B	24	φ36.8	φ39.3	φ35.8	B1	2	φ6	φ25	7	9	M4	3.5	35.8
SW48B 26 + B	26	φ39.8	φ42.4	φ38.8	B1	2	φ6	φ25	7	9	M4	3.5	39.0
SW48B 28 + B	28	φ42.9	φ45.5	φ41.9	B1	2	φ6	φ25	7	9	M4	3.5	42.0
SW48B 30 + B	30	φ45.9	φ48.5	φ44.9	B1	2	φ6	φ25	7	9	M4	3.5	45.3

【+】にはセットスクリーンが付いております。

【+】: Gear with threaded hole / with set screw.

RoHS 対応

2006年11月生産開始分より欧州 RoHS 指令に対応できる商品を提供しています。

We supplied the KG-products with RoHS compliance of EU to all our valued customers since November 2006

- 目次 CONTENTS
- インフォメーション INFORMATION
- ギヤボックス GEAR BOXES
- ノーバッキングギヤ ANTI BACKLASH SPUR GEARS
- 歯研研歯歯車 GROUND SPUR GEARS
- 平歯車 SPUR GEARS
- 内歯車 INTERNAL GEARS
- 歯研ラック GROUND RACKS
- ラック RACKS
- へリカル・スクリューギヤ HELICAL GEARS AND SCREW GEARS
- ワーム・ワームホイール WORMS AND WORM WHEELS
- かさ歯車 BEVEL GEARS
- スプロケット SPROCKETS
- 技術データ REFERENCE DATA

ブッシュチェーン用ホイール

SPROCKETS for BUSHED CHAIN

ピッチ PITCH **6.35** 片ハブ付

称呼寸法 25、6.35 × 3.175mm (1/4"×1/8")
 ピッチ 6.35mm (1/4") 単列
 Bushed Chain : 6.35 Pitch × 3.175 (1/4"×1/8") Single Strand

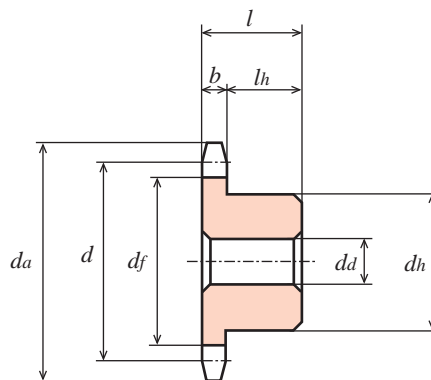

B1形
TYPE B1

ポリアセタール (白色)
Material : Ploy Acetal (White)

単位 : mm
Dimensions : mm

商品記号 Catalogue Number	歯数 Number of Teeth z	基準円直径 Reference Diameter d	外径 Outside Diameter da	歯底円直径 Root Diameter df	形 Type	歯幅 Face Width b	穴径 Bore Diameter dd	ハブ外径 Hub Diameter dh	ハブ長さ Hub Projection lh	全長 Overall Length l	重量 Weight W(g)
SW1/4D 8 - B	8	φ16.6	φ19.1	φ13.3	B1	2.8	φ 6	φ10	10	12.8	1.3
SW1/4D 9 - B	9	φ18.6	φ21.3	φ15.3	B1	2.8	φ 6	φ10	10	12.8	1.5
SW1/4D 10 - B	10	φ20.5	φ23.4	φ17.2	B1	2.8	φ 8	φ14	10	12.8	2.4
SW1/4D 11 - B	11	φ22.5	φ25.4	φ19.2	B1	2.8	φ 8	φ16	10	12.8	3.4
SW1/4D 12 - B	12	φ24.5	φ27.5	φ21.2	B1	2.8	φ 8	φ18	10	12.8	4.3
SW1/4D 13 - B	13	φ26.5	φ29.6	φ23.2	B1	2.8	φ 8	φ20	10	12.8	5.5
SW1/4D 14 - B	14	φ28.5	φ31.6	φ25.2	B1	2.8	φ 8	φ22	10	12.8	6.8
SW1/4D 15 - B	15	φ30.5	φ33.7	φ27.2	B1	2.8	φ 8	φ22	10	12.8	7.1
SW1/4D 16 - B	16	φ32.5	φ35.7	φ29.2	B1	2.8	φ 8	φ26	12	14.8	11.0
SW1/4D 17 - B	17	φ34.6	φ37.8	φ31.3	B1	2.8	φ 8	φ26	12	14.8	11.4
SW1/4D 18 - B	18	φ36.6	φ39.8	φ33.3	B1	2.8	φ 8	φ28	12	14.8	12.9
SW1/4D 19 - B	19	φ38.6	φ41.9	φ35.3	B1	2.8	φ 8	φ28	12	14.8	13.5
SW1/4D 20 - B	20	φ40.6	φ43.9	φ37.3	B1	2.8	φ 8	φ28	15	17.8	16.6
SW1/4D 21 - B	21	φ42.6	φ45.9	φ39.3	B1	2.8	φ 8	φ35	15	17.8	24.4
SW1/4D 22 - B	22	φ44.6	φ48	φ41.3	B1	2.8	φ 8	φ35	15	17.8	24.9
SW1/4D 23 - B	23	φ46.6	φ50	φ43.3	B1	2.8	φ 8	φ35	15	17.8	25.5
SW1/4D 24 - B	24	φ48.6	φ52	φ45.3	B1	2.8	φ 8	φ35	15	17.8	26.0
SW1/4D 25 - B	25	φ50.7	φ54.1	φ47.3	B1	2.8	φ 8	φ35	15	17.8	26.7
SW1/4D 26 - B	26	φ52.7	φ56.1	φ49.4	B1	2.8	φ10	φ35	15.2	18	26.8
SW1/4D 28 - B	28	φ56.7	φ60.2	φ53.4	B1	2.8	φ10	φ38	15.2	18	32.1
SW1/4D 30 - B	30	φ60.7	φ64.2	φ57.4	B1	2.8	φ10	φ38	15.2	18	33.7
SW1/4D 32 - B	32	φ64.8	φ68.3	φ61.5	B1	2.8	φ12	φ42	15.2	18	39.8

スプロケットの計算

1. 基準円直径の求めかた

$$d = \frac{\text{ピッチ (mm)}}{\sin \frac{180^\circ}{\text{歯数}}} \text{ (mm)}$$

2. 外径の求めかた

$$da = \text{ピッチ (mm)} \left(0.6 + \cot \frac{180^\circ}{\text{歯数}} \right) \text{ (mm)}$$

Calculation

1. Obtain the Reference diameter of Sprocket

$$d = \frac{\text{Pitch (mm)}}{\sin \frac{180^\circ}{\text{Number of teeth}}} \text{ (mm)}$$

2. Obtain the outside diameter of Sprocket

$$da = \text{Pitch (mm)} \left(0.6 + \cot \frac{180^\circ}{\text{Number of teeth}} \right) \text{ (mm)}$$

ブッシュチェーン用ホイール

SPROCKETS for BUSHED CHAIN

ピッチ PITCH **6.35** 片ハブ付

称呼寸法 25、6.35 × 3.175mm (1/4"×1/8")
 ピッチ 6.35mm (1/4") 単列
 Bushed Chain : 6.35 Pitch × 3.175 (1/4"×1/8") Single Strand



御注文には必ず“フルネームで商品記号”を明記してください。
 Please refer to the catalogue reference while ordering.

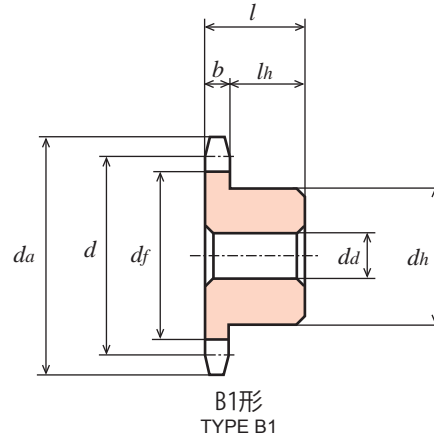

S45C 機械構造用炭素鋼 (JIS G 4051)

Material : Carbon Steel (ISO C45)

単位 : mm
Dimensions : mm

商品記号 Catalogue Number	歯数 Number of Teeth <i>z</i>	基準円直径 Reference Diameter <i>d</i>	外径 Outside Diameter <i>da</i>	歯底円直径 Root Diameter <i>df</i>	形 Type	歯幅 Face Width <i>b</i>	穴径 Bore Diameter <i>da(H9)</i>	ハブ外径 Hub Diameter <i>dh</i>	ハブ長さ Hub Projection <i>lh</i>	全長 Overall Length <i>l</i>	重量 Weight <i>W(g)</i>
SW1/4S 8 - B	8	φ16.6	φ19.1	φ13.3	B1	2.8	φ 6	φ10	10	12.8	7.3
SW1/4S 9 - B	9	φ18.6	φ21.3	φ15.3	B1	2.8	φ 6	φ10	10	12.8	8.5
SW1/4S 10 - B	10	φ20.5	φ23.4	φ17.2	B1	2.8	φ 8	φ14	10	12.8	13.3
SW1/4S 11 - B	11	φ22.5	φ25.4	φ19.2	B1	2.8	φ 8	φ16	10	12.8	18.4
SW1/4S 12 - B	12	φ24.5	φ27.5	φ21.2	B1	2.8	φ 8	φ18	10	12.8	24.3
SW1/4S 13 - B	13	φ26.5	φ29.6	φ23.2	B1	2.8	φ 8	φ20	10	12.8	30.6
SW1/4S 14 - B	14	φ28.5	φ31.6	φ25.2	B1	2.8	φ 8	φ22	10	12.8	37.4
SW1/4S 15 - B	15	φ30.5	φ33.7	φ27.2	B1	2.8	φ 8	φ22	10	12.8	39.5
SW1/4S 16 - B	16	φ32.5	φ35.7	φ29.2	B1	2.8	φ 8	φ26	12	14.8	60.6
SW1/4S 17 - B	17	φ34.6	φ37.8	φ31.3	B1	2.8	φ 8	φ26	12	14.8	62.9
SW1/4S 18 - B	18	φ36.6	φ39.8	φ33.3	B1	2.8	φ 8	φ28	12	14.8	73.0
SW1/4S 19 - B	19	φ38.6	φ41.9	φ35.3	B1	2.8	φ 8	φ28	12	14.8	75.7
SW1/4S 20 - B	20	φ40.6	φ43.9	φ37.3	B1	2.8	φ 8	φ28	15	17.8	91.8
SW1/4S 21 - B	21	φ42.6	φ45.9	φ39.3	B1	2.8	φ 8	φ35	15	17.8	135.0
SW1/4S 22 - B	22	φ44.6	φ48	φ41.3	B1	2.8	φ 8	φ35	15	17.8	137.9
SW1/4S 23 - B	23	φ46.6	φ50	φ43.3	B1	2.8	φ 8	φ35	15	17.8	141.9
SW1/4S 24 - B	24	φ48.6	φ52	φ45.3	B1	2.8	φ 8	φ35	15	17.8	143.9
SW1/4S 25 - B	25	φ50.7	φ54.1	φ47.3	B1	2.8	φ 8	φ35	15	17.8	147.2
SW1/4S 26 - B	26	φ52.7	φ56.1	φ49.4	B1	2.8	φ10	φ35	15.2	18	148.4
SW1/4S 28 - B	28	φ56.7	φ60.2	φ53.4	B1	2.8	φ10	φ38	15.2	18	177.3
SW1/4S 30 - B	30	φ60.7	φ64.2	φ57.4	B1	2.8	φ10	φ38	15.2	18	184.6
SW1/4S 32 - B	32	φ64.8	φ68.3	φ61.5	B1	2.8	φ12	φ42	15.2	18	217.6

- 目次 CONTENTS
- インフォメーション INFORMATION
- ギヤボックス GEAR BOXES
- ノーバッキングギヤ ANTI BACKLASH SPUR GEARS
- 歯研削歯車 GROUND SPUR GEARS
- 平歯車 SPUR GEARS
- 内歯車 INTERNAL GEARS
- 歯研削ラック GROUND RACKS
- ラック RACKS
- （リ）カハ・スクリューギヤ HEICAL GEARS AND SCREW GEARS
- マートル・マートルホイール WORMS AND WORM WHEELS
- かみ歯車 BEVEL GEARS
- スプロケット SPROCKETS
- 技 術 参 考 資 料 REFERENCE DATA

技術資料

硬さ換算表

鋼のビッカース硬さに対する近似的換算値

ビッカース 硬さ	ブリネル硬さ 10mm球・荷重3000kgf			ロックウェル硬さ ⁽²⁾				ロックウェルスーパーフィシャル硬さ ダイヤモンド円錐圧子			シヨア硬さ	引張強さ (近似値) MPa (kgf/mm ²) ⁽¹⁾	ビッカース 硬さ荷重
	標準球	Hult-gren 球	タングステン カーバイド 球	Aスケール 荷重60kgf ダイヤモンド 円錐圧子	Bスケール 荷重100kgf 径1/16in 球	Cスケール 荷重150kgf ダイヤモンド 円錐圧子	Dスケール 荷重100kgf ダイヤモンド 円錐圧子	15-N スケール 荷重15kgf	30-N スケール 荷重30kgf	45-N スケール 荷重45kgf			
940	-	-	-	85・6	-	68・0	76・9	93・2	84・4	75・4	97	-	940
920	-	-	-	85・3	-	67・5	76・5	93・0	84・0	74・8	96	-	920
900	-	-	-	85・0	-	67・0	76・1	92・9	83・6	74・2	95	-	900
880	-	-	(767)	84・7	-	66・4	75・7	92・7	83・1	73・6	93	-	880
860	-	-	(757)	84・4	-	65・9	75・3	92・5	82・7	73・1	92	-	860
840	-	-	(745)	84・1	-	65・3	74・8	92・3	82・2	72・2	91	-	840
820	-	-	(733)	83・8	-	64・7	74・3	92・1	81・7	71・8	90	-	820
800	-	-	(722)	83・4	-	64・0	73・8	91・8	81・1	71・0	88	-	800
780	-	-	(710)	83・0	-	63・3	73・3	91・5	80・4	70・2	87	-	780
760	-	-	(698)	82・6	-	62・5	72・6	91・2	79・7	69・4	86	-	760
740	-	-	(684)	82・2	-	61・8	72・1	91・0	79・1	68・6	84	-	740
720	-	-	(670)	81・8	-	61・0	71・5	90・7	78・4	67・7	83	-	720
700	-	615	(656)	81・3	-	60・1	70・8	90・3	77・6	66・7	81	-	700
690	-	610	(647)	81・1	-	59・7	70・5	90・1	77・2	66・2	-	-	690
680	-	603	(638)	80・8	-	59・2	70・1	89・8	76・8	65・7	80	-	680
670	-	597	630	80・6	-	58・8	69・8	89・7	76・4	65・3	-	-	670
660	-	590	620	80・3	-	58・3	69・4	89・5	75・9	64・7	79	-	660
650	-	585	611	80・0	-	57・8	69・0	89・2	75・5	64・1	-	-	650
640	-	578	601	79・8	-	57・3	68・7	89・0	75・1	63・5	77	-	640
630	-	571	591	79・5	-	56・8	68・3	88・8	74・6	63・0	-	-	630
620	-	564	582	79・2	-	56・3	67・9	88・5	74・2	62・4	75	-	620
610	-	557	573	78・9	-	55・7	67・5	88・2	73・6	61・7	-	-	610
600	-	550	564	78・6	-	55・2	67・0	88・0	73・2	61・2	74	-	600
590	-	542	554	78・4	-	54・7	66・7	87・8	72・7	60・5	-	2055 (210)	590
580	-	535	545	78・0	-	54・1	66・2	87・5	72・1	59・9	72	2020 (206)	580
570	-	527	535	77・8	-	53・6	65・8	87・2	71・7	59・3	-	1985 (202)	570
560	-	519	525	77・4	-	53・0	65・4	86・9	71・2	58・6	71	1950 (199)	560
550	(505)	512	517	77・0	-	52・3	64・8	86・6	70・5	57・8	-	1905 (194)	550
540	(496)	503	507	76・7	-	51・7	64・4	86・3	70・0	57・0	69	1860 (190)	540
530	(488)	495	497	76・4	-	51・1	63・9	86・0	69・5	56・2	-	1825 (186)	530
520	(480)	487	488	76・1	-	50・5	63・5	85・7	69・0	55・6	67	1795 (183)	520
510	(473)	479	479	75・7	-	49・8	62・9	85・4	68・3	54・7	-	1750 (179)	510
500	(465)	471	471	75・3	-	49・1	62・2	85・0	67・7	53・9	66	1705 (174)	500
490	(456)	460	460	74・9	-	48・4	61・6	84・7	67・1	53・1	-	1660 (169)	490
480	448	452	452	74・5	-	47・7	61・3	84・3	66・4	52・2	64	1620 (165)	480
470	441	442	442	74・1	-	46・9	60・7	83・9	65・7	51・3	-	1570 (160)	470
460	433	433	433	73・6	-	46・1	60・1	83・6	64・9	50・4	62	1530 (156)	460
450	425	425	425	73・3	-	45・3	59・4	83・2	64・3	49・4	-	1495 (153)	450
440	415	415	415	72・8	-	44・5	58・8	82・8	63・5	48・4	59	1460 (149)	440
430	405	405	405	72・3	-	43・6	58・2	82・3	62・7	47・4	-	1410 (144)	430
420	397	397	397	71・8	-	42・7	57・5	81・8	61・9	46・4	57	1370 (140)	420
410	388	388	388	71・4	-	41・8	56・8	81・4	61・1	45・3	-	1330 (136)	410
400	379	379	379	70・8	-	40・8	56・0	81・0	60・2	44・1	55	1290 (131)	400
390	369	369	369	70・3	-	39・8	55・2	80・3	59・3	42・9	-	1240 (127)	390
380	360	360	380	69・8	(110・0)	38・8	54・4	79・8	58・4	41・7	52	1205 (123)	380
370	350	350	350	69・2	-	37・7	53・6	79・2	57・4	40・4	-	1170 (120)	370
360	341	341	341	68・7	(109・0)	36・6	52・8	78・6	56・4	39・1	50	1130 (115)	360
350	331	331	331	68・1	-	35・5	51・9	78・0	55・4	37・8	-	1095 (112)	350
340	322	322	322	67・6	(108・0)	34・4	51・1	77・4	54・4	36・5	47	1070 (109)	340
330	313	313	313	67・0	-	33・3	50・2	76・8	53・6	35・2	-	1035 (105)	330

鋼のビッカース硬さに対する近似的換算値

ビッカース 硬さ	ブリネル硬さ 10mm球・荷重3000kgf			ロックウェル硬さ ⁽²⁾				ロックウェルスーパーフィシャル硬さ ダイヤモンド円錐圧子			シヨア硬さ	引張強さ (近似値) MPa (kgf/mm ²) ⁽¹⁾	ビッカース 硬さ荷重
	標準球	Hult-gren 球	タンダステン カーバイド 球	Aスケール 荷重60kgf ダイヤモンド 円錐圧子	Bスケール 荷重100kgf 径1/16in 球	Cスケール 荷重150kgf ダイヤモンド 円錐圧子	Dスケール 荷重100kgf ダイヤモンド 円錐圧子	15-N スケール 荷重15kgf	30-N スケール 荷重30kgf	45-N スケール 荷重45kgf			
320	303	303	303	66.4	(107.0)	33.2	49.4	76.2	52.3	33.9	45	1005 (103)	320
310	294	294	294	65.8	-	31.0	48.4	75.6	51.3	32.5	-	980 (100)	310
300	284	284	284	65.2	(105.5)	29.8	47.5	74.9	50.2	31.1	42	950 (97)	300
295	280	280	280	64.8	-	29.2	47.1	74.6	49.7	30.4	-	935 (96)	295
290	275	275	275	64.5	(104.5)	28.5	46.5	74.2	49.0	29.5	41	915 (94)	290
285	270	270	270	64.2	-	27.8	46.0	73.8	48.4	28.7	-	905 (92)	285
280	265	265	265	63.8	(103.5)	27.1	45.3	73.4	47.8	27.9	40	890 (91)	280
275	261	261	261	63.5	-	26.4	44.9	73.0	47.2	27.1	-	875 (89)	275
270	256	256	256	63.1	(102.0)	25.6	44.3	72.6	46.4	26.2	38	855 (87)	270
265	252	252	252	62.7	-	24.8	43.7	72.1	45.7	25.2	-	840 (86)	265
260	247	247	247	62.4	(101.0)	24.0	43.1	71.6	45.0	24.3	37	825 (84)	260
255	243	243	243	62.0	-	23.1	42.2	71.1	44.2	23.2	-	805 (82)	255
250	238	238	238	61.6	99.5	22.2	41.7	70.6	43.4	22.2	36	795 (81)	250
245	233	233	233	61.2	-	21.3	41.1	70.1	42.5	21.1	-	780 (79)	245
240	228	228	228	60.7	98.1	20.3	40.3	69.6	41.7	19.9	34	765 (78)	240
230	219	219	219	-	96.7	(18.0)	-	-	-	-	33	730 (75)	230
220	209	209	209	-	95.0	(15.7)	-	-	-	-	32	695 (71)	220
210	200	200	200	-	93.4	(13.4)	-	-	-	-	30	670 (68)	210
200	190	190	190	-	91.5	(11.0)	-	-	-	-	29	635 (65)	200
190	181	181	181	-	89.5	(8.5)	-	-	-	-	28	605 (62)	190
180	171	171	171	-	87.1	(6.0)	-	-	-	-	26	580 (59)	180
170	162	162	162	-	85.0	(3.0)	-	-	-	-	25	545 (56)	170
160	152	152	152	-	81.7	(0.0)	-	-	-	-	24	515 (53)	160
150	143	143	143	-	78.7	-	-	-	-	-	22	490 (50)	150
140	133	133	133	-	75.0	-	-	-	-	-	21	455 (46)	140
130	124	124	124	-	71.2	-	-	-	-	-	20	425 (44)	130
120	114	114	114	-	66.7	-	-	-	-	-	-	390 (40)	120
110	105	105	105	-	62.3	-	-	-	-	-	-	-	110
100	95	95	95	-	56.2	-	-	-	-	-	-	-	100
95	90	90	90	-	52.0	-	-	-	-	-	-	-	95
90	86	86	86	-	48.0	-	-	-	-	-	-	-	90
85	81	81	81	-	41.0	-	-	-	-	-	-	-	85

備考：太字体の数字はASTM E 140表1による（SAE-ASM-ASTMが合同で調整したものである。）

注：（1）括弧（ ）を付けて示してある単位及び数値は、JIS Z 8438の換算表により psi から換算したものである。

なお 1MPa = 1N/mm²

（2）表中括弧（ ）内の数字はあまり用いられない範囲のものであり参考として示したものである。

（3）JISハンドブック鉄鋼より引用

鋼のロックウェルC硬さに対する近似的換算値 (1)

ロックウェルCスケール硬さ	ピッカース硬さ	ブリネル硬さ 10mm球・荷重3000kgf			ロックウェル硬さ ⁽²⁾			ロックウェルスーパーフィシャル硬さ ダイヤモンド円錐圧子			シヨア硬さ	引張強さ (近似値) MPa (kgf/mm ²) ⁽¹⁾	ロックウェルCスケール硬さ
		標準球	Hult-gren球	タンダステンカーバイド球	Aスケール 荷重60kgf ダイヤモンド 円錐圧子	Bスケール 荷重100kgf 径1/16in 球	Dスケール 荷重100kgf ダイヤモンド 円錐圧子	15-N スケール 荷重15kgf	30-N スケール 荷重30kgf	45-N スケール 荷重45kgf			
68	940	-	-	-	85・6	-	76・9	93・2	84・4	75・4	97	-	68
67	900	-	-	-	85・0	-	76・1	92・9	83・6	74・2	95	-	67
66	865	-	-	-	84・5	-	75・4	92・5	82・8	73・3	92	-	66
65	832	-	-	(739)	83・9	-	74・5	92・2	81・9	72・0	91	-	65
64	800	-	-	(722)	83・4	-	73・8	91・8	81・1	71・0	88	-	64
63	772	-	-	(705)	82・8	-	73・0	91・4	80・1	69・9	87	-	63
62	746	-	-	(688)	82・3	-	72・2	91・1	79・3	68・8	85	-	62
61	720	-	-	(670)	81・8	-	71・5	90・7	78・4	67・7	83	-	61
60	697	-	613	(654)	81・2	-	70・7	90・2	77・5	66・6	81	-	60
59	674	-	599	(634)	80・7	-	69・9	89・8	76・6	65・5	80	-	59
58	653	-	587	615	80・1	-	69・2	89・3	75・7	64・3	78	-	58
57	633	-	575	595	79・6	-	68・5	88・9	74・8	63・2	76	-	57
56	613	-	561	577	79・0	-	67・7	88・3	73・9	62・0	75	-	56
55	595	-	546	560	78・5	-	66・9	87・9	73・0	60・9	74	2075 (212)	55
54	577	-	534	543	78・0	-	66・1	87・4	72・0	59・8	72	2015 (205)	54
53	560	-	519	525	77・4	-	65・4	86・9	71・2	58・6	71	1950 (199)	53
52	544	(500)	508	512	76・8	-	64・6	86・4	70・2	57・4	69	1880 (192)	52
51	528	(487)	494	496	76・3	-	63・8	85・9	69・4	56・1	68	1820 (186)	51
50	513	(475)	481	481	75・9	-	63・1	85・5	68・5	55・0	67	1760 (179)	50
49	498	(464)	469	469	75・2	-	62・1	85・0	67・6	53・8	66	1695 (173)	49
48	484	451	455	455	74・7	-	61・4	84・5	66・7	52・5	64	1635 (167)	48
47	471	442	443	443	74・1	-	60・8	83・9	65・8	51・4	63	1580 (161)	47
46	458	432	432	432	73・6	-	60・0	83・5	64・8	50・3	62	1530 (156)	46
45	446	421	421	421	73・1	-	59・2	83・0	64・0	49・0	60	1480 (151)	45
44	434	409	409	409	72・5	-	58・5	82・5	63・1	47・8	58	1435 (146)	44
43	423	400	400	400	72・0	-	57・7	82・0	62・2	46・7	57	1385 (141)	43
42	412	390	390	390	71・5	-	56・9	81・5	61・3	45・5	56	1340 (136)	42
41	402	381	381	381	70・9	-	56・2	80・9	60・4	44・3	55	1295 (132)	41
40	392	371	371	371	70・4	-	55・4	80・4	59・5	43・1	54	1250 (127)	40
39	382	362	362	362	69・9	-	54・6	79・9	58・6	41・9	52	1215 (124)	39
38	372	353	353	353	69・4	-	53・8	79・4	57・7	40・8	51	1180 (120)	38
37	363	344	344	344	68・9	-	53・1	78・8	56・8	39・6	50	1160 (118)	37
36	354	336	336	336	68・4	(109・0)	52・3	78・3	55・9	38・4	49	1115 (114)	36
35	345	327	327	327	67・9	(108・5)	51・5	77・7	55・0	37・2	48	1080 (110)	35
34	336	319	319	319	67・4	(108・0)	50・8	77・2	54・2	36・1	47	1055 (108)	34
33	327	311	311	311	66・8	(107・5)	50・0	76・6	53・3	34・9	46	1025 (105)	33
32	318	301	301	301	66・3	(107・0)	49・2	76・1	52・1	33・7	44	1000 (102)	32
31	310	294	294	294	65・8	(106・0)	48・4	75・6	51・3	32・5	43	980 (100)	31
30	302	286	286	286	65・3	(105・5)	47・7	75・0	50・4	31・3	42	950 (97)	30
29	294	279	279	279	64・7	(104・5)	47・0	74・5	49・5	30・1	41	930 (95)	29

鋼のロックウェルC硬さに対する近似的換算値 (1)

ロックウェルCスケール硬さ	ピッカース硬さ	ブリネル硬さ 10mm球・荷重3000kgf			ロックウェル硬さ ⁽²⁾			ロックウェルスーパーフィシャル硬さ ダイヤモンド円錐圧子			シヨア硬さ	引張強さ (近似値) MPa (kgf/mm ²) ⁽¹⁾	ロックウェルCスケール硬さ
		標準球	Hult-gren球	タンクステンカーバイド球	Aスケール 荷重60kgf ダイヤモンド 円錐圧子	Bスケール 荷重100kgf 径1/16in 球	Dスケール 荷重100kgf ダイヤモンド 円錐圧子	15-N スケール 荷重15kgf	30-N スケール 荷重30kgf	45-N スケール 荷重45kgf			
28	286	271	271	271	64・3	(104・0)	46・1	73・9	48・6	28・9	41	910 (93)	28
27	279	264	264	264	63・8	(103・0)	45・2	73・3	47・7	27・8	40	880 (90)	27
26	272	258	258	258	63・3	(102・5)	44・6	72・8	46・8	26・7	38	860 (88)	26
25	266	253	253	253	62・8	(101・5)	43・8	72・2	45・9	25・5	38	840 (86)	25
24	260	247	247	247	62・4	(101・0)	43・1	71・6	45・0	24・3	37	825 (84)	24
23	254	243	243	243	62・0	100・0	42・1	71・0	44・0	23・1	36	805 (82)	23
22	248	237	237	237	61・5	99・0	41・6	70・5	43・2	22・0	35	785 (80)	22
21	243	231	231	231	61・0	98・5	40・9	69・9	42・3	20・7	35	770 (79)	21
20	238	226	226	226	60・5	97・8	40・1	69・4	41・5	19・6	34	760 (77)	20
(18)	230	219	219	219	-	96・7	-	-	-	-	33	730 (75)	(18)
(16)	222	212	212	212	-	95・5	-	-	-	-	32	705 (72)	(16)
(14)	213	203	203	203	-	93・9	-	-	-	-	31	675 (69)	(14)
(12)	204	194	194	194	-	92・3	-	-	-	-	29	650 (66)	(12)
(10)	196	187	187	187	-	90・7	-	-	-	-	28	620 (63)	(10)
(8)	188	179	179	179	-	89・5	-	-	-	-	27	600 (61)	(8)
(6)	180	171	171	161	-	87・1	-	-	-	-	26	580 (59)	(6)
(4)	173	165	165	165	-	85・5	-	-	-	-	25	550 (56)	(4)
(2)	166	158	158	158	-	83・5	-	-	-	-	24	530 (54)	(2)
(0)	160	152	152	152	-	81・7	-	-	-	-	24	515 (53)	(0)

- 注： (1) 太字体の数字はASTM E 140表1による (SAE-ASM-ASTMが合同で調整したものである。)
(2) 括弧 () を付けて示してある単位及び数値は、JIS Z 8438換算表により psi から換算したものである。
なお 1MPa = 1N/mm²
(3) JISハンドブック鉄鋼より引用

常用するはめ合いの穴の寸法許容差

単位：μm

寸法の区分 (mm)		B		C		D			E			F			G		H					
をこえ	以下	B10	C9	C10	D8	D9	D10	E7	E8	E9	F6	F7	F8	G6	G7	H6	H7	H8	H9	H10	H11	
-	3	+180 +140	+85 +60	+100	+34	+45 +20	+60	+24	+28 +14	+39	+12	+16 +6	+20	+8 +2	+12	+6	+10	+14	+25	+40	+60	
3	6	+188 +140	+100 +70	+118	+48	+60 +30	+78	+32	+38 +20	+50	+18	+22 +10	+28	+12 +4	+16	+8	+12	+18	+30	+48	+75	
6	10	+208 +150	+116 +80	+138	+62	+76 +40	+98	+40	+47 +25	+61	+22	+28 +13	+35	+14 +5	+20	+9	+15	+22	+36	+58	+90	
10	14	+220	+138	+165	+77	+93	+120	+50	+59	+75	+27	+34	+43	+17	+24	+11	+18	+27	+43	+70	+110	
14	18	+150	+95			+50			+32			+16		+6								
18	24	+244	+162	+194	+98	+117	+149	+61	+73	+92	+33	+41	+53	+20	+28	+13	+21	+33	+52	+84	+130	
24	30	+160	+110			+65			+40			+20		+7								
30	40	+270 +170	+182 +120	+220	+119	+142	+180	+75	+89	+112	+41	+50	+64	+25	+34	+16	+25	+39	+62	+100	+160	
40	50	+280 +180	+192 +130	+230		+80			+50			+25		+9								
50	65	+310 +190	+214 +140	+260	+146	+174	+220	+90	+106	+134	+49	+60	+76	+29	+40	+19	+30	+46	+74	+120	+190	
65	80	+320 +200	+224 +150	+270		+100			+60			+30		+10								
80	100	+360 +220	+257 +170	+310	+174	+207	+260	+107	+126	+159	+58	+71	+90	+34	+47	+22	+35	+54	+87	+140	+220	
100	120	+380 +240	+267 +180	+320		+120			+72			+36		+12								
120	140	+420 +260	+300 +200	+360																		
140	160	+440 +280	+310 +210	+370	+208	+245 +145	+305	+125	+148 +85	+185	+68	+83 +43	+106	+39 +14	+54	+25	+40	+63	+100	+160	+250	
160	180	+470 +310	+330 +230	+390																		
180	200	+525 +340	+355 +240	+425																		
200	225	+565 +380	+375 +260	+445	+242	+285 +170	+355	+146	+172 +100	+215	+79	+96 +50	+122	+44 +15	+61	+29	+46	+72	+115	+185	+290	
225	250	+605 +420	+395 +280	+465																		
250	280	+690 +480	+430 +300	+510	+271	+320	+400	+162	+191 +110	+240	+88	+108 +56	+137	+49 +17	+69	+32	+52	+81	+130	+210	+320	
280	315	+750 +540	+460 +330	+540		+190																
315	355	+830 +600	+500 +360	+590	+299	+350	+440	+182	+214 +125	+265	+98	+119 +62	+151	+54 +18	+75	+36	+57	+89	+140	+230	+360	
355	400	+910 +680	+540 +400	+630		+210																
400	450	+1010 +760	+595 +440	+690	+327	+385	+480	+198	+232 +135	+290	+108	+131 +68	+165	+60 +20	+83	+40	+63	+97	+155	+250	+400	
450	500	+1090 +840	+635 +480	+730		+230																

備考 表中の各段で、上側の数値は上ノ寸法許容差、下側の数値は下ノ寸法許容差を示す。

常用するはめ合いの穴の寸法許容差

単位：μm

寸法の区分 (mm)		Js				K		M		N		P		R	S	T	U	X				
をこえ	以下	Js6	Js7	Js8	Js9	K6	K7	M6	M7	N6	N7	P6	P7	R7	S7	T7	U7	X7				
-	3	±3	±5	±7	±12.5	0 -6	0 -10	-2 -8	-2 -12	-4 -10	-4 -14	-6 -12	-6 -16	-10 -20	-14 -24	-	-18 -28	-20 -30				
3	6	±4	±6	±9	±15	+2 -6	+3 -9	-1 -9	0 -12	-5 -13	-4 -16	-9 -17	-8 -20	-11 -23	-15 -27	-	-19 -31	-24 -36				
6	10	±4.5	±7.5	±11	±18	+2 -7	+5 -10	-3 -12	0 -15	-7 -16	-4 -19	-12 -21	-9 -24	-13 -28	-17 -32	-	-22 -37	-28 -43				
10	14	±5.5	±9	±13.5	±21.5	+2	+6	-4	0	-9	-5	-15	-11	-16	-21	-	-26	-33				
14	18					-9	-12	-15	-18	-20	-23	-26	-29	-34	-39		-44	-51	-56			
18	24	±6.5	±10.5	±16.5	±26	+2	+6	-4	0	-11	-7	-18	-14	-20	-27	-	-54	-67				
24	30					-11	-15	-17	-21	-24	-28	-31	-35	-41	-48	-33	-40	-56	-77			
30	40	±8	±12.5	±19.5	±31	+3	+7	-4	0	-12	-8	-21	-17	-25	-31	-39	-51	-				
40	50					-13	-18	-20	-25	-28	-33	-37	-42	-50	-59	-64	-76	-61	-86			
50	65	±9.5	±15	±23	±37	+4	+9	-5	0	-14	-9	-26	-21	-30	-42	-55	-76	-				
65	80					-15	-21	-24	-30	-33	-39	-45	-51	-60	-72	-85	-106	-91	-121			
80	100	±11	±17.5	±27	±43.5	+4	+10	-6	0	-16	-10	-30	-21	-38	-58	-78	-111	-				
100	120					-18	-25	-28	-35	-38	-45	-52	-59	-73	-93	-113	-146	-131	-166			
120	140	±12.5	±20	±31.5	±50	+4 -21	+12 -28	-8 -33	0 -40	-20 -45	-12 -52	-36 -61	-28 -68	-48	-77	-107	-	-	-			
140	160													-88	-117	-147				-50	-85	-119
160	180													-90	-125	-159				-53	-93	-131
180	200	±14.5	±23	±36	±57.5	+5 -24	+13 -33	-8 -37	0 -46	-22 -51	-14 -60	-41 -70	-33 -79	-60	-105	-	-	-	-			
200	225													-106	-151	-63				-113	-109	-159
225	250													-67	-123	-113				-169		
250	280	±16	±26	±40.5	±65	+5	+16	-9	0	-25	-14	-47	-36	-74	-	-	-	-				
280	315					-27	-36	-41	-52	-57	-66	-79	-88	-126	-78	-130						
315	355	±18	±28.5	±44.5	±70	+7	+17	-10	0	-26	-16	-51	-41	-87	-	-	-	-				
355	400					-29	-40	-46	-57	-62	-73	-87	-93	-144	-93	-150						
400	450					-103	-166	-109	-172													
450	500	±20	±31.5	±48.5	±77.5	+8 -32	+18 -45	-10 -50	0 -63	-27 -67	-17 -80	-55 -95	-45 -108	-	-	-	-					

備考 表中の各段で、上側の数値は上ノ寸法許容差、下側の数値は下ノ寸法許容差を示す。

常用するはめ合いの軸の寸法許容差

単位：μm

寸法の区分 (mm)		js				k		m		n	p	r	s	t	u	x
をこえ	以下	js5	js6	js7	js8	k5	k6	m5	m6	n6	p6	r6	s6	t6	u6	x6
-	3	±2	±3	±5	±7	+4 0	+6	+6 +2	+8	+10 +4	+12 +6	+16 +10	+20 +14	-	+24 +18	+26 +20
3	6	±2.5	±4	±6	±9	+6 +1	+9	+9 +4	+12	+16 +8	+20 +12	+23 +15	+27 +19	-	+31 +23	+36 +28
6	10	±3	±4.5	±7.5	±11	+7 +1	+10	+12 +6	+15	+19 +10	+24 +15	+28 +19	+32 +23	-	+37 +28	+43 +34
10	14	±4	±5.5	±9	±13.5	+9 +1	+12	+15 +7	+18	+23 +12	+29 +18	+34 +23	+39 +28	-	+44 +33	+51
14	18															+40
18	24	±4.5	±6.5	±10.5	±16.5	+11 +2	+15	+17 +8	+21	+28 +15	+35 +22	+41 +28	+48 +35	-	+54	+67
24	30													+41	+48	+77
30	40	±5.5	±8	±12.5	±19.5	+13 +2	+18	+20 +9	+25	+33 +17	+42 +26	+50 +34	+59 +43	+64	+76	-
40	50													+48	+60	+86
50	65	±6.5	±9.5	±15	±23	+15 +2	+21	+24 +11	+30	+30 +20	+51 +32	+60	+72	+85	+106	-
65	80											+41	+53	+66	+87	
80	100	±7.5	±11	±17.5	±27	+18 +3	+25	+28 +13	+35	+45 +23	+59 +37	+73	+93	+113	+146	-
100	120											+51	+71	+104	+124	
120	140	±9	±12.5	±20	±31.5	+21 +3	+28	+33 +15	+40	+52 +27	+68 +43	+88	+117	+147	-	-
140	160											+63	+92	+122	+159	
160	180											+65	+100	+134	+171	
180	200	±10	±14.5	±23	±36	+24 +4	+33	+37 +17	+46	+60 +31	+79 +50	+106	+151	+171	-	-
200	225											+77	+122	+159	+130	
225	250											+80	+130	+169	+140	
250	280	±11.5	±16	±26	±40.5	+27 +4	+36	+43 +20	+52	+66 +34	+88 +56	+126	-	-	-	-
280	315											+94	+130	+140	+98	
315	355	±12.5	±18	±28.5	±44.5	+29 +4	+40	+46 +21	+57	+73 +37	+98 +62	+144	-	-	-	-
355	400											+108	+150	+114	+114	
400	450	±13.5	±20	±31.5	±48.5	+32 +5	+45	+50 +23	+63	+80 +40	+108 +68	+166	-	-	-	-
450	500											+126	+172	+132	+132	

備考 表中の各段で、上側の数値は上ノ寸法許容差、下側の数値は下ノ寸法許容差を示す。

常用するはめ合いの軸の寸法許容差

単位：μm

寸法の区分 (mm)		b	c	d		e			f			g		h						
をこえ	以下	b9	c9	d8	d9	e7	e8	e9	f6	f7	f8	g5	g6	h5	h6	h7	h8	h9	h10	h11
-	3	-140 -165	-60 -85	-20 -34 -45		-14 -24 -28 -39			-6 -12 -16 -20			-2 -6 -8		0 -4 -6 -10 -14 -25 -40 -60						
3	6	-140 -170	-70 -100	-30 -48 -60		-20 -32 -38 -50			-10 -18 -22 -28			-4 -9 -12		0 -5 -8 -12 -18 -30 -48 -75						
6	10	-150 -186	-80 -116	-40 -62 -76		-25 -40 -47 -61			-13 -22 -28 -35			-5 -11 -14		0 -6 -9 -15 -22 -36 -58 -90						
10	14	-150	-95	-50		-32			-16			-6		0						
14	18	-193	-138	-77	-93	-50	-59	-75	-27	-34	-43	-14	-17	-8	-11	-18	-27	-43	-70	-110
18	24	-160	-110	-65		-40			-20			-7		0						
24	30	-212	-162	-98	-117	-61	-73	-92	-33	-41	-53	-16	-20	-9	-13	-21	-33	-52	-84	-130
30	40	-170 -232	-120 -182	-80		-50			-25			-9		0						
40	50	-180 -242	-130 -192	-119	-142	-75	-89	-112	-41	-50	-64	-20	-25	-11	-16	-25	-39	-62	-100	-160
50	65	-190 -264	-140 -214	-100		-60			-30			-10		0						
65	80	-200 -274	-150 -224	-146	-174	-90	-106	-134	-49	-60	-76	-23	-29	-13	-19	-30	-46	-74	-120	-190
80	100	-220 -307	-170 -257	-120		-72			-36			-12		0						
100	120	-240 -327	-180 -267	-174	-207	-107	-126	-159	-58	-71	-90	-27	-34	-15	-22	-35	-54	-87	-140	-220
120	140	-260 -360	-200 -300	-145		-85			-43			-14		0						
140	160	-280 -380	-210 -310	-208	-245	-125	-148	-185	-68	-83	-106	-32	-39	-18	-25	-40	-63	-100	-160	-250
160	180	-310 -410	-230 -330	-170		-100			-50			-15		0						
180	200	-340 -455	-240 -355	-242	-285	-146	-172	-215	-79	-96	-122	-35	-44	-20	-29	-46	-72	-115	-185	-290
200	225	-380 -495	-260 -375	-170		-100			-50			-15		0						
225	250	-420 -535	-280 -395	-190		-110			-56			-17		0						
250	280	-480 -610	-300 -430	-271	-320	-162	-191	-240	-88	-108	-137	-40	-49	-23	-32	-52	-81	-130	-210	-320
280	315	-540 -670	-330 -460	-210		-125			-62			-18		0						
315	355	-600 -710	-360 -500	-299	-350	-182	-214	-265	-98	-119	-151	-43	-54	-25	-36	-57	-89	-140	-230	-260
355	400	-680 -820	-400 -540	-230		-135			-68			-20		0						
400	450	-760 -915	-440 -595	-327	-385	-198	-232	-290	-108	-131	-165	-47	-60	-27	-40	-63	-97	-155	-250	-400
450	500	-840 -995	-480 -635	-230		-135			-68			-20		0						

備考 表中の各段で、上側の数値は上ノ寸法許容差、下側の数値は下ノ寸法許容差を示す。

メートル並目および細目ネジのピッチと下穴参考ドリル寸法

単位：mm

ネジの呼び	ピッチ				下穴参考ドリル径	
	並目	細目			並目	ヘリサート
M1	0.25	0.2			0.75	
M1.1	0.25	0.2			0.85	
M1.2	0.25	0.2			0.95	
M1.4	0.3	0.2			1.1	
M1.6	0.35	0.2			1.25	
M1.8	0.35	0.2			1.45	
M2	0.4	0.25			1.6	2.1
M2.2	0.45	0.25			1.75	2.4
M2.5	0.45	0.35			2.1	2.6
M3	0.5	0.35			2.5	3.1
M3.5	0.6	0.35			2.9	3.7
M4	0.7	0.5			3.3	4.2
M4.5	0.75	0.5			3.8	3.6
M5	0.8	0.5			4.2	5.2
M6	1	0.75			5	6.3
M8	1.25	0.75	1		6.8	8.4
M10	1.5	0.75	1	1.25	8.5	10.5
M12	1.75	1	1.25	1.5	10.3	12.5
M14	2	1	1.25	1.5	12	14.5
M16	2	1	1.5	1.5	14	16.5
M18	2.5	1	1.5	2	15.5	19
M20	2.5	1	1.5	2	17.5	21
M22	2.5	1	1.5	2	19.5	23
M24	3	1	1.5	2	21	25
M27	3	1	1.5	2	24	28
M30	3.5	1	1.5	2	26.5	31

JISB0205.0207抜粋

次に記載することがらは、参考のために示すものであって、規格の一部ではない。

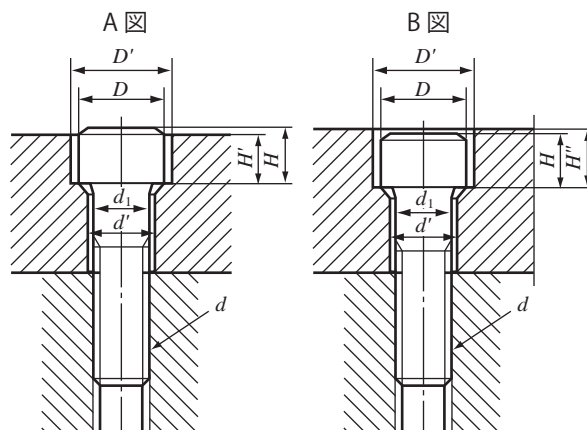

六角穴付きボルトに対するざぐりおよびボルト穴の寸法

単位: mm

ねじの呼び (d)	M3	M4	M5	M6	M8	M10	M12	M14	M16	M18	M20	M22	M24	M27	M30	M33	M36	M39	M42	M45	M48	M52
d_1	3	4	5	6	8	10	12	14	16	18	20	22	24	27	30	33	36	39	42	45	48	52
d'	3.4	4.5	5.5	6.6	9	11	14	16	18	20	22	24	26	30	33	36	39	42	45	48	52	56
D	5.5	7	8.5	10	13	16	18	21	24	27	30	33	36	40	45	50	54	58	63	68	72	78
D'	6.5	8	9.5	11	14	17.5	20	23	26	29	32	35	39	43	48	54	58	62	67	72	76	82
H	3	4	5	6	8	10	12	14	16	18	20	22	24	27	30	33	36	39	42	45	48	52
H'	2.7	3.6	4.6	5.5	7.4	9.2	11	12.8	14.5	16.5	18.5	20.5	22.5	25	28	31	34	37	39	42	45	49
H''	3.3	4.4	5.4	6.5	8.6	10.8	13	15.2	17.5	19.5	21.5	23.5	25.5	29	32	35	38	41	44	47	50	54

備考 上表のボルト穴径 (d') は、JIS B 1001 (ボルト穴径及びざぐり径) のボルト穴径2級による。

平行キ一用キ一溝の形状及び寸法

キ一溝の断面

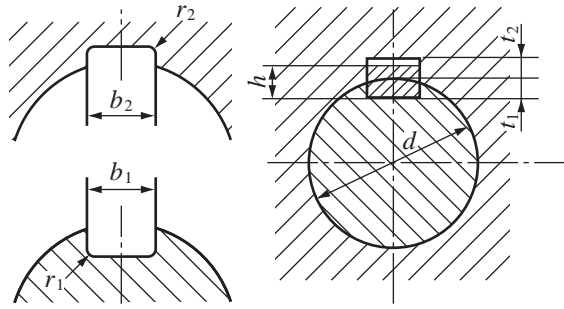

単位：mm

キ一の呼び寸法 $b \times h$	b_1 及び b_2 の基準寸法	滑動形		普通形		締込み形	r_1 及び r_2	r_1 の基準寸法	r_2 の基準寸法	h_1 及び h_2 の許容差	対応する軸(穴)径 d (参考)	対応するKGギヤの穴径
		b_1	b_2	b_1	b_2	b_1 及び b_2						
		許容差(H9)	許容差(D10)	許容差(N9)	許容差(Js9)	許容差(P9)						
2×2	2	+0.025	+0.060	-0.004	±0.0125	-0.006	0.08 ~ 0.16	1.2	1.0	+0.1 0	6 ~ 8	
3×3	3	0	+0.020	-0.029	-0.031	1.8		1.4	8 ~ 10		8,10	
4×4	4	+0.030 0	+0.078 -0.030	0 -0.030	±0.0150	-0.012 -0.042		2.5	1.8		10 ~ 12	12
5×5	5						3.0	2.3	12 ~ 17	14,15,16		
6×6	6						3.5	2.8	17 ~ 22	18,20,22		
(7×7)	7	+0.036 0	+0.098 +0.040	0 -0.036	±0.0180	-0.015 -0.051	0.16 ~ 0.25	4.0	3.3	+0.2 0	20 ~ 25	
8×7	8							4.0	3.3		22 ~ 30	25,28,30
10×8	10							5.0	3.3		30 ~ 38	32,35
12×8	12	+0.043 0	+0.120 +0.050	0 -0.043	±0.0215	-0.018 -0.061	0.25 ~ 0.40	5.0	3.3	+0.3 0	38 ~ 44	40
14×9	14							5.5	3.8		44 ~ 50	45,50
(15×10)	15							5.0	5.3		50 ~ 55	
16×10	16	+0.052 0	+0.149 +0.065	0 -0.052	±0.0260	-0.022 -0.074	0.40 ~ 0.60	6.0	4.3	+0.3 0	50 ~ 58	
18×11	18							7.0	4.4		58 ~ 65	
20×12	20							7.5	4.9		65 ~ 75	
22×14	22	+0.062 0	+0.180 +0.080	0 -0.062	±0.0310	-0.026 -0.088	0.70 ~ 1.00	9.0	5.4	+0.3 0	75 ~ 85	
(24×16)	24							8.0	8.4		80 ~ 90	
25×14	25							9.0	5.4		85 ~ 95	
28×16	28	+0.074 0	+0.220 +0.100	0 -0.072	±0.0370	-0.032 -0.106	1.20 ~ 1.60	10.0	6.4	+0.3 0	95 ~ 110	
32×18	32							11.0	7.4		110 ~ 130	
(35×22)	35							11.0	11.4		125 ~ 140	
36×20	36	+0.087 0	+0.260 +0.120	0 -0.087	±0.0435	-0.037 -0.124	2.00 ~ 2.50	12.0	8.4	+0.3 0	130 ~ 150	
(38×24)	38							12.0	12.4		140 ~ 160	
40×22	40							13.0	9.4		150 ~ 170	
(42×26)	42	13.0	13.4	160 ~ 180								
45×25	45	+0.074 0	+0.220 +0.100	0 -0.072	±0.0370	-0.032 -0.106	1.20 ~ 1.60	15.0	10.4	+0.3 0	170 ~ 200	
50×28	50							17.0	11.4		200 ~ 230	
56×32	56							20.0	12.4		230 ~ 260	
63×32	63	+0.087 0	+0.260 +0.120	0 -0.087	±0.0435	-0.037 -0.124	2.00 ~ 2.50	20.0	12.4	+0.3 0	260 ~ 290	
70×36	70							22.0	14.4		290 ~ 330	
80×40	80							25.0	15.4		330 ~ 380	
90×45	90	+0.087 0	+0.260 +0.120	0 -0.087	±0.0435	-0.037 -0.124	2.00 ~ 2.50	28.0	17.4	+0.3 0	380 ~ 440	
100×50	100							31.0	19.5		440 ~ 500	

JIS B1301準拠

センタ穴旧 JIS B1011

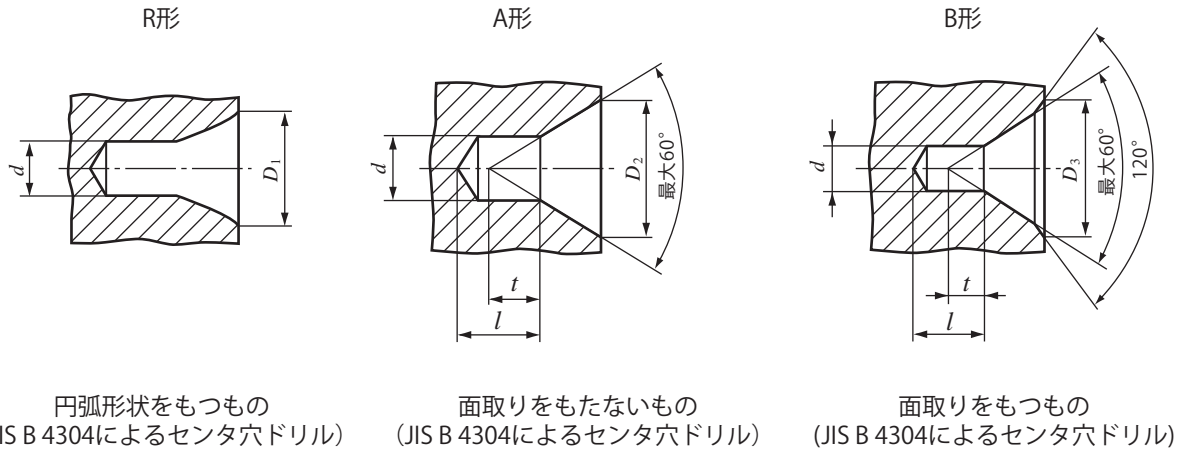

注*: 寸法 l は、センタ穴ドリルの長さに基づくが、t よりも短くてはならない。

推奨するセンタ穴の寸法

単位: mm

d 呼び	種類				
	R 形 JIS B 4304による	A 形 JIS B 4304による		B 形 JIS B 4304による	
	D ₁ 呼び	D ₂ 呼び	t 参考	D ₃ 呼び	t 参考
(0.5)		1.06	0.5		
(0.63)		1.32	0.6		
(0.8)		1.70	0.7		
1.0	2.12	2.12	0.9	3.15	0.9
(1.25)	2.65	2.65	1.1	4	1.1
1.6	3.35	3.35	1.4	5	1.4
2.0	4.25	4.25	1.8	6.3	1.8
2.5	5.3	5.30	2.2	8	2.2
3.15	6.7	6.70	2.8	10	2.8
4.0	8.5	8.50	3.5	12.5	3.5
(5.0)	10.6	10.60	4.4	16	4.4
6.3	13.2	13.20	5.5	18	5.5
(8.0)	17.0	17.00	7.0	22.4	7.0
10.0	21.2	21.20	8.7	28	8.7

備考 括弧を付けて示した呼びのものは、なるべく用いない。

C形止め輪軸用 (参考)

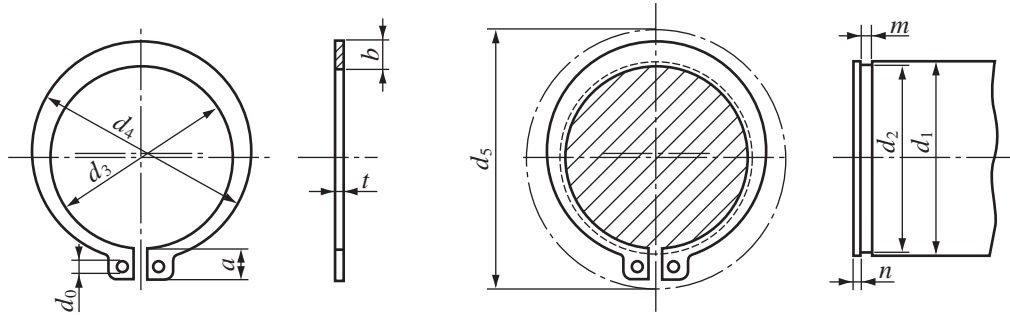

直径 d の穴の位置は、止め輪を適用する軸に入れたとき、みぞにかくれないようにする。

d_5 は、軸にはめるときの外周の最大径。

単位：mm

呼び		止め輪							適用する軸 (参考)						
1	2	d_3		t		b	a	d_0 (最小)	d_5	d_1	d_2		m		n (最小)
		基準寸法	許容差	基準寸法	許容差						基準寸法	許容差	基準寸法	許容差	
10	11	9.3	±0.15	1	±0.05	1.6	3	1.2	17	10	9.6	0 -0.09	1.15	0	1.5
		10.2				1.8	3.1		18	11	10.5				
12	14	11.1	±0.18	1	±0.05	1.8	3.2	1.5	19	12	11.5	0 -0.11	1.15	0	1.5
14		12.9				2	3.4		22	14	13.4				
15	16	13.8	±0.18	1	±0.05	2.1	3.5	1.7	23	15	14.3	0 -0.11	1.15	0	1.5
16		14.7				2.2	3.6		24	16	15.2				
17	18	15.7	±0.18	1	±0.05	2.2	3.7	1.7	25	17	16.2	0 -0.11	1.15	0	1.5
18		16.5				2.6	3.8		26	18	17				
20	22	18.5	±0.2	1.2	±0.06	2.7	3.8	2	27	19	18	0 -0.21	1.35	0	1.5
22		20.5				2.7	3.9		CC	20	19				
24	25	22.2	±0.2	1.2	±0.06	3.1	4.2	2	31	22	21	0 -0.21	1.35	0	1.5
25		23.2				3.1	4.3		33	24	22.9				
26	28	24.2	±0.2	1.6	±0.06	3.1	4.4	2	34	25	23.9	0 -0.21	1.75	+0.14 0	1.5
28		25.9				3.1	4.6		35	26	24.9				
30	32	27.9	±0.25	1.6	±0.06	3.5	4.8	2	40	30	28.6	0 -0.25	1.75	+0.14 0	1.5
32		29.6				3.5	5		43	32	30.3				
35	36	32.2	±0.25	1.8	±0.07	4	5.4	2.5	46	35	33	0 -0.25	1.95	0	2
36		33.2				4	5.4		47	36	34				
38	40	35.2	±0.4	1.8	±0.07	4.5	5.6	2.5	50	38	36	0 -0.25	1.95	0	2
40		37				4.5	5.8		53	40	38				
42	45	38.5	±0.4	1.8	±0.07	4.5	6.2	2.5	55	42	39.5	0 -0.25	1.95	0	2
45		41.5				4.8	6.3		58	45	42.5				
48	50	44.5	±0.45	2	±0.08	4.8	6.5	2.5	62	48	45.5	0 -0.3	2.2	0	2
50		45.8				5	6.7		64	50	47				
55	56	50.8	±0.45	2	±0.08	5	7	2.5	70	55	52	0 -0.3	2.2	0	2
56		51.8				5	7		71	56	53				
60	65	55.8	±0.45	2.5	±0.08	5.5	7.2	2.5	75	60	57	0 -0.3	2.7	0	2.5
65		60.8				6.4	7.4		81	65	62				
70	75	65.5	±0.55	3	±0.09	6.4	7.8	3	86	70	67	0 -0.35	3.2	+0.18 0	3
75		70.5				7	7.9		92	75	72				
80	85	74.5	±0.55	3	±0.09	7.4	8.2	3	97	80	76.5	0 -0.35	3.2	+0.18 0	3
85		79.5				8	8.4		103	85	81.5				
90	95	84.5	±0.55	3	±0.09	8	8.7	3	108	90	86.5	0 -0.35	3.2	+0.18 0	3
95		89.5				8.6	9.1		114	95	91.5				
100	105	94.5	±0.55	4	±0.09	9	9.5	3	119	100	96.5	0 -0.54	4.2	0	4
105		98				9.5	9.8		125	105	101				
110	113	103	±0.55	4	±0.09	9.5	10	3	131	110	106	0 -0.54	4.2	0	4
113		103				10.3	10.9		143	120	116				

C形止め輪穴用 (参考)

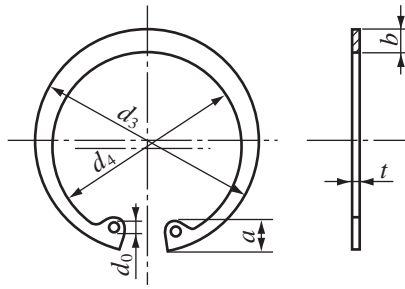

直径 d_0 の穴の位置は、止め輪を適用する穴に入れたとき、みぞにかくれないようにする。

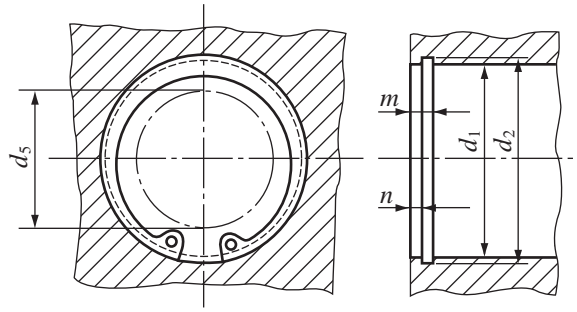

d_5 は、穴にはめるときの内周の最小径。

単位：mm

呼び		止め輪							適用する穴 (参考)													
		d_3		t		b	a	d_0	d_5	d_1	d_2		m		n (最小)							
1	2	基準寸法	許容差	基準寸法	許容差	約	約	最小			基準寸法	許容差	基準寸法	許容差								
10		10.7	±0.18	1	±0.05	1.8	3.1	1.2	3	10	10.4	+0.11 0	1.15	1.5								
11		11.8				1.8	3.2		4	11	11.4											
12		13.0				1.8	3.3	1.5	5	12	12.5											
13		14.1				1.8	3.5		6	13	13.6											
14		15.1				2.0	3.6	1.7	7	14	14.6											
15		16.2				2.0	3.6		8	15	15.7											
16		17.3				2.0	3.7		8	16	16.8											
17		18.3				2.0	3.8		9	17	17.8											
18		19.5				±0.20	1.2	±0.06	2.5	4.0	2					10	18	19.0	+0.21 0	1.35	1.5	
19		20.5							2.5	4.0						11	19	20.0				
20		21.5	2.5	4.0	12				20	21.0												
21		22.5	2.5	4.1	13				22	23.0												
22		23.5	2.5	4.3	1.6				15	24	25.2											
23		24.5	3.0	4.4					16	25	26.2											
24		25.9	3.0	4.6					16	26	27.2											
25		26.9	3.0	4.6					18	28	29.4											
26		27.9	±0.25	1.8	±0.07				3.0	4.7	2.5	20	30	31.4	+0.25 0	1.75	+0.14 0	2				
27		28.9							3.5	5.2		21	32	33.7								
28		30.1				3.5	5.2	24	35	37.0												
29		31.3				3.5	5.2	25	36	38.0												
30		32.1				3.5	5.2	26	37	39.0												
31		33.4				4.0	5.3	27	38	40.0												
32		34.4				4.0	5.7	28	40	42.5												
33		35.4				4.0	5.8	30	42	44.5												
34		36.8				4.5	5.9	33	45	47.5												
35		37.8				4.5	6.1	34	47	49.5												
36		38.8	4.5	6.2	35	48	50.5															
37		39.8	4.5	6.5	37	50	53.0															
38		40.8	5.1	6.5	39	52	55.0															
39		41.8	5.1	6.5	41	55	58.0															
40		43.5	5.1	6.6	42	56	59.0															
41		45.5	5.5	6.8	46	60	63.0															
42		45.5	5.5	6.9	48	62	65.0															
43		48.5	5.5	6.9	49	63	66.0															
44		48.5	5.5	7.0	50	65	68.0															
45		50.5	6.0	7.4	53	68	71.0															
46		50.5	6.0	7.4	55	70	73.0															
47		51.5	6.6	7.4	57	72	75.0															
48		51.5	6.6	7.8	60	75	78.0															
49		54.2	7.0	8.0	64	80	83.5															
50		54.2	7.0	8.0	69	85	88.5															
51		56.2	7.6	8.3	73	90	93.5															
52		56.2	8.0	8.5	77	95	98.5															
53		59.2	8.3	8.8	82	100	103.5															
54		59.2	8.9	9.1	86	105	109.0															
55		60.2	8.9	10.2	89	110	114.0															
56		60.2	8.9	10.2	90	112	116.0															
57		64.2	9.5	10.2	94	115	119.0															
58		64.2	9.5	10.7	98	120	124.0															
59		66.2	10.0	10.7	103	125	129.0															
60		66.2	±0.45	2.5	±0.08	6.0	7.4	53	68	71.0	+0.30 0	2.7	2.5									
61		67.2	5.5	6.9	50	65	68.0															
62		67.2	5.5	7.0	53	68	71.0	55	70	73.0	+0.35 0	3.2	3									
63		69.2	6.0	7.4	57	72	75.0															
64		69.2	6.0	7.4	60	75	78.0	64	80	83.5	+0.54 0	4.2	+0.18 0	4								
65		72.5	6.6	7.4	64	80	83.5															
66		74.5	7.0	8.0	69	85	88.5	73	90	93.5	+0.63 0											
67		74.5	7.6	8.3	73	90	93.5															
68		76.5	8.0	8.5	77	95	98.5	77	95	98.5	+0.54 0	4.2	+0.18 0	4								
69		79.5	8.3	8.8	82	100	103.5															
70		79.5	8.9	9.1	86	105	109.0	86	105	109.0	+0.63 0											
71		85.5	8.9	10.2	89	110	114.0															
72		85.5	8.9	10.2	90	112	116.0	89	110	114.0	+0.63 0											
73		90.5	9.5	10.2	94	115	119.0															
74		90.5	9.5	10.7	98	120	124.0	94	115	119.0	+0.63 0											
75		95.5	10.0	10.7	103	125	129.0	98	120	124.0					+0.63 0							
76		95.5	±0.55	3	±0.09	8.9	9.1	86	105	109.0	+0.63 0											
77		100.5	8.9	10.2	89	110	114.0															
78		100.5	8.9	10.2	90	112	116.0	89	110	114.0	+0.63 0											
79		105.5	9.5	10.2	94	115	119.0															
80		105.5	9.5	10.7	98	120	124.0	94	115	119.0	+0.63 0											
81	105	112.0	±0.65	4	±0.09	8.9	9.1	86	105	109.0					+0.63 0							
82		112.0	8.9	10.2	89	110	114.0															
83		117.0	8.9	10.2	90	112	116.0	89	110	114.0	+0.63 0											
84		117.0	9.5	10.2	94	115	119.0															
85		119.0	9.5	10.7	98	120	124.0	94	115	119.0	+0.63 0											
86		122.0	10.0	10.7	103	125	129.0	98	120	124.0					+0.63 0							
87		122.0	±0.65	4	±0.09	8.9	9.1	86	105	109.0	+0.63 0											
88		127.0	8.9	10.2	89	110	114.0															
89		127.0	8.9	10.2	90	112	116.0	89	110	114.0	+0.63 0											
90		127.0	9.5	10.2	94	115	119.0															
91		127.0	9.5	10.7	98	120	124.0	94	115	119.0	+0.63 0											
92		132.0	10.0	10.7	103	125	129.0	98	120	124.0					+0.63 0							
93		132.0	±0.65	4	±0.09	8.9	9.1	86	105	109.0	+0.63 0											
94		132.0	8.9	10.2	89	110	114.0															
95		132.0	8.9	10.2	90	112	116.0	89	110	114.0	+0.63 0											
96		132.0	9.5	10.2	94	115	119.0															
97		132.0	9.5	10.7	98	120	124.0	94	115	119.0	+0.63 0											
98		132.0	10.0	10.7	103	125	129.0	98	120	124.0					+0.63 0							
99		132.0	±0.65	4	±0.09	8.9	9.1	86	105	109.0	+0.63 0											
100		132.0	8.9	10.2	89	110	114.0															
101		132.0	8.9	10.2	90	112	116.0	89	110	114.0	+0.63 0											
102		132.0	9.5	10.2	94	115	119.0															
103		132.0	9.5	10.7	98	120	124.0	94	115	119.0	+0.63 0											
104		132.0	10.0	10.7	103	125	129.0	98	120	124.0					+0.63 0							

E 形止め輪 (参考)

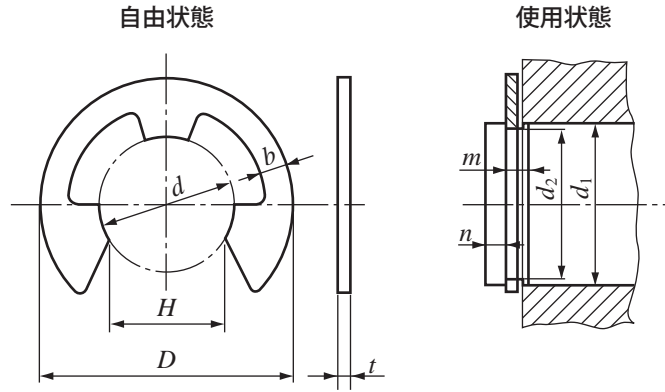

備考 形状は、一例を示す。

単位：mm

呼び	止め輪										適用する軸 (参考)								
	d		D		H		t		b		d ₂ の区分		d ₂		m		n (最小)		
	基準 寸法	許容差	基準 寸法	許容差	基準 寸法	許容差	基準 寸法	許容差	約	を越え	以下	基準 寸法	許容差	基準 寸法	許容差				
0.8	0.8	0 -0.08	2	±0.1	0.7	0 -0.25	0.2	±0.02	0.3	1	1.4	0.8	+0.05 0	0.3	+0.05 0	0.4			
1.2	1.2	0 -0.09	3	±0.2	1		0.3	±0.025	0.4	1.4	2	1.2	+0.06 0	0.4		+0.1 0	0.6		
1.5	1.5		4		1.3		0.4	0.6	2	2.5	1.5	+0.075 0		0.5			+0.14 0	0.8	
2	2		5		1.7	0.4	0.7	2.5	3.2	2	+0.09 0			1.15	2				
2.5	2.5		6		2.1	0.4	0.8	3.2	4	2.5								1.8	3
3	3		7		2.6	0.6	0.9	4	5	3									
4	4	9	3.5	0	0.6	1.1	5	7	4	2.4	4								
5	5	0 -0.12	11	±0.2	4.3	0	0.6	±0.04	1.2			6	8	5	1.75	4			
6	6	0 -0.15	12	±0.3	5.2	0	0.8	±0.05	1.4	7	9	6	+0.13 0	2.2					
7	7		14		6.1	0.8	1.6	8	11	7	1.9	2.5							
8	8		16		6.9	0.8	1.8	9	12	8					2.8	3.5			
9	9		18		7.8	0.8	2	10	14	9							4	5	
10	10		20		8.7	1	2.2	11	15	10									
12	12	0 -0.18	23	±0.3	10.4	0	1	±0.06	2.4	13	18	12	+0.14 0	2.2					
15	15	0 -0.21	29		13	0	1.6	±0.07	2.8	16	24	15			2.2				
19	19		37		16.5	0	1.6	4	20	31	19								
24	24	0 -0.21	44		20.8	0 -0.5	2	±0.07	5	25	38	24							

Reference data

Conversion table for SI units (International System of Units)

	N	dyn	kgf
Force	1	1×10^5	1.01972×10^{-1}
	1×10^{-5}	1	1.01972×10^{-6}
	9.806 65	9.80665×10^5	1

	Pa	bar	kgf/cm ²	atm	mmH ₂ O	mmHg or Torr
Pressure	1	1×10^{-5}	1.01972×10^{-5}	9.86923×10^{-6}	1.01972×10^{-1}	7.50062×10^{-3}
	1×10^5	1	1.019 72	9.86923×10^{-1}	1.01972×10^4	7.50062×10^2
	9.80665×10^4	9.80665×10^{-1}	1	9.67841×10^{-1}	1×10^4	7.35559×10^2
	1.01325×10^5	1.013 25	1.033 23	1	1.03323×10^4	7.60000×10^2
	9.806 65	9.80665×10^{-5}	1×10^{-4}	9.67841×10^{-5}	1	7.35559×10^{-2}
	1.33322×10^2	1.33322×10^{-3}	1.35951×10^{-3}	1.31579×10^{-3}	1.35951×10	1

Note IPa=IN/m²

	Pa	Mpa or N/mm ²	kfg/mm ²	kgf/cm ²
Stress	1	1×10^{-6}	1.01972×10^{-7}	1.01972×10^{-5}
	1×10^6	1	1.01972×10^{-1}	1.01972×10
	9.80665×10^6	9.806 65	1	1×10^2
	9.80665×10^4	9.80665×10^{-2}	1×10^{-2}	1

	Pa·s	cP	P
Coefficient of viscosity	1	1×10^3	1×10
	1×10^{-3}	1	1×10^{-2}
	1×10^{-1}	1×10^2	1

Note IP = Idyn·s/cm² = Ig/cm·S,
IPa·s = IN·s/m², IcP = ImPa·s

Hardness conversion table

Approximate conversion values compared with Vickers hardness of Steel

Vickers hardness	Brinell hardness 10 mm ball 3000kgf			Rockwell hardness ⁽²⁾				Rockwell superficial hardness diamond cone penetrator			Shore hardness	Tensile strength (Approx. value) MPa (kgf/mm ²) ⁽¹⁾	Vickers hardness Load
	Standard ball	Hult-gren ball	Tungsten carbide ball	Scale A Load 60kgf Diamond cone penetrator	Scale B Load 100kgf 1/16 inch Ball	Scale C Load 150kgf Diamond cone penetrator	Scale D Load 100kgf Diamond cone penetrator	15-N Scale Load 15 kgf	30-N Scale Load 30 kgf	45-N Scale Load 45 kgf			
940	-	-	-	85.6	-	68.0	76.9	93.2	84.4	75.4	97	-	940
920	-	-	-	85.3	-	67.5	76.5	93.0	84.0	74.8	96	-	920
900	-	-	-	85.0	-	67.0	76.1	92.9	83.6	74.2	95	-	900
880	-	-	(767)	84.7	-	66.4	75.7	92.7	83.1	73.6	93	-	880
860	-	-	(757)	84.4	-	65.9	75.3	92.5	82.7	73.1	92	-	860
840	-	-	(745)	84.1	-	65.3	74.8	92.3	82.2	72.2	91	-	840
820	-	-	(733)	83.8	-	64.7	74.3	92.1	81.7	71.8	90	-	820
800	-	-	(722)	83.4	-	64.0	73.8	91.8	81.1	71.0	88	-	800
780	-	-	(710)	83.0	-	63.3	73.3	91.5	80.4	70.2	87	-	780
760	-	-	(698)	82.6	-	62.5	72.6	91.2	79.7	69.4	86	-	760
740	-	-	(684)	82.2	-	61.8	72.1	91.0	79.1	68.6	84	-	740
720	-	-	(670)	81.8	-	61.0	71.5	90.7	78.4	67.7	83	-	720
700	-	615	(656)	81.3	-	60.1	70.8	90.3	77.6	66.7	81	-	700
690	-	610	(647)	81.1	-	59.7	70.5	90.1	77.2	66.2	-	-	690
680	-	603	(638)	80.8	-	59.2	70.1	89.8	76.8	65.7	80	-	680
670	-	597	630	80.6	-	58.8	69.8	89.7	76.4	65.3	-	-	670
660	-	590	620	80.3	-	58.3	69.4	89.5	75.9	64.7	79	-	660
650	-	585	611	80.0	-	57.8	69.0	89.2	75.5	64.1	-	-	650
640	-	578	601	79.8	-	57.3	68.7	89.0	75.1	63.5	77	-	640
630	-	571	591	79.5	-	56.8	68.3	88.8	74.6	63.0	-	-	630
620	-	564	582	79.2	-	56.3	67.9	88.5	74.2	62.4	75	-	620
610	-	557	573	78.9	-	55.7	67.5	88.2	73.6	61.7	-	-	610
600	-	550	564	78.6	-	55.2	67.0	88.0	73.2	61.2	74	-	600
590	-	542	554	78.4	-	54.7	66.7	87.8	72.7	60.5	-	2055 (210)	590
580	-	535	545	78.0	-	54.1	66.2	87.5	72.1	59.9	72	2020 (206)	580
570	-	527	535	77.8	-	53.6	65.8	87.2	71.7	59.3	-	1985 (202)	570
560	-	519	525	77.4	-	53.0	65.4	86.9	71.2	58.6	71	1950 (199)	560
550	(505)	512	517	77.0	-	52.3	64.8	86.6	70.5	57.8	-	1905 (194)	550
540	(496)	503	507	76.7	-	51.7	64.4	86.3	70.0	57.0	69	1860 (190)	540
530	(488)	495	497	76.4	-	51.1	63.9	86.0	69.5	56.2	-	1825 (186)	530
520	(480)	487	488	76.1	-	50.5	63.5	85.7	69.0	55.6	67	1795 (183)	520
510	(473)	479	479	75.7	-	49.8	62.9	85.4	68.3	54.7	-	1750 (179)	510
500	(465)	471	471	75.3	-	49.1	62.2	85.0	67.7	53.9	66	1705 (174)	500
490	(456)	460	460	74.9	-	48.4	61.6	84.7	67.1	53.1	-	1660 (169)	490
480	448	452	452	74.5	-	47.7	61.3	84.3	66.4	52.2	64	1620 (165)	480
470	441	442	442	74.1	-	46.9	60.7	83.9	65.7	51.3	-	1570 (160)	470
460	433	433	433	73.6	-	46.1	60.1	83.6	64.9	50.4	62	1530 (156)	460
450	425	425	425	73.3	-	45.3	59.4	83.2	64.3	49.4	-	1495 (153)	450
440	415	415	415	72.8	-	44.5	58.8	82.8	63.5	48.4	59	1460 (149)	440
430	405	405	405	72.3	-	43.6	58.2	82.3	62.7	47.4	-	1410 (144)	430
420	397	397	397	71.8	-	42.7	57.5	81.8	61.9	46.4	57	1370 (140)	420
410	388	388	388	71.4	-	41.8	56.8	81.4	61.1	45.3	-	1330 (136)	410
400	379	379	379	70.8	-	40.8	56.0	81.0	60.2	44.1	55	1290 (131)	400
390	369	369	369	70.3	-	39.8	55.2	80.3	59.3	42.9	-	1240 (127)	390
380	360	360	380	69.8	(110.0)	38.8	54.4	79.8	58.4	41.7	52	1205 (123)	380
370	350	350	350	69.2	-	37.7	53.6	79.2	57.4	40.4	-	1170 (120)	370
360	341	341	341	68.7	(109.0)	36.6	52.8	78.6	56.4	39.1	50	1130 (115)	360
350	331	331	331	68.1	-	35.5	51.9	78.0	55.4	37.8	-	1095 (112)	350
340	322	322	322	67.6	(108.0)	34.4	51.1	77.4	54.4	36.5	47	1070 (109)	340
330	313	313	313	67.0	-	33.3	50.2	76.8	53.6	35.2	-	1035 (105)	330

Approximate conversion values compared with Vickers hardness for Steel

Vickers hardness	Brinell hardness 10 mm ball 3000kgf			Rockwell hardness ⁽²⁾				Rockwell superficial hardness diamond cone penetrator			Shore hardness	Tensile strength (Approx. value) MPa (⁽¹⁾)	Vickers hardness Load
	Standard ball	Hult-gren ball	Tungsten carbide ball	Scale A Load 60kgf Diamond cone penetrator	Scale B Load 100kgf 1/16 inch Ball	Scale C Load 150kgf Diamond cone penetrator	Scale D Load 100kgf Diamond cone penetrator	15-N Scale Load 15 kgf	30-N Scale Load 30 kgf	45-N Scale Load 45 kgf			
320	303	303	303	66·4	(107·0)	33·2	49·4	76·2	52·3	33·9	45	1005 (103)	320
310	294	294	294	65·8	-	31·0	48·4	75·6	51·3	32·5	-	980 (100)	310
300	284	284	284	65·2	(105·5)	29·8	47·5	74·9	50·2	31·1	42	950 (97)	300
295	280	280	280	64·8	-	29·2	47·1	74·6	49·7	30·4	-	935 (96)	295
290	275	275	275	64·5	(104·5)	28·5	46·5	74·2	49·0	29·5	41	915 (94)	290
285	270	270	270	64·2	-	27·8	46·0	73·8	48·4	28·7	-	905 (92)	285
280	265	265	265	63·8	(103·5)	27·1	45·3	73·4	47·8	27·9	40	890 (91)	280
275	261	261	261	63·5	-	26·4	44·9	73·0	47·2	27·1	-	875 (89)	275
270	256	256	256	63·1	(102·0)	25·6	44·3	72·6	46·4	26·2	38	855 (87)	270
265	252	252	252	62·7	-	24·8	43·7	72·1	45·7	25·2	-	840 (86)	265
260	247	247	247	62·4	(101·0)	24·0	43·1	71·6	45·0	24·3	37	825 (84)	260
255	243	243	243	62·0	-	23·1	42·2	71·1	44·2	23·2	-	805 (82)	255
250	238	238	238	61·6	99·5	22·2	41·7	70·6	43·4	22·2	36	795 (81)	250
245	233	233	233	61·2	-	21·3	41·1	70·1	42·5	21·1	-	780 (79)	245
240	228	228	228	60·7	98·1	20·3	40·3	69·6	41·7	19·9	34	765 (78)	240
230	219	219	219	-	96·7	(18·0)	-	-	-	-	33	730 (75)	230
220	209	209	209	-	95·0	(15·7)	-	-	-	-	32	695 (71)	220
210	200	200	200	-	93·4	(13·4)	-	-	-	-	30	670 (68)	210
200	190	190	190	-	91·5	(11·0)	-	-	-	-	29	635 (65)	200
190	181	181	181	-	89·5	(8·5)	-	-	-	-	28	605 (62)	190
180	171	171	171	-	87·1	(6·0)	-	-	-	-	26	580 (59)	180
170	162	162	162	-	85·0	(3·0)	-	-	-	-	25	545 (56)	170
160	152	152	152	-	81·7	(0·0)	-	-	-	-	24	515 (53)	160
150	143	143	143	-	78·7	-	-	-	-	-	22	490 (50)	150
140	133	133	133	-	75·0	-	-	-	-	-	21	455 (46)	140
130	124	124	124	-	71·2	-	-	-	-	-	20	425 (44)	130
120	114	114	114	-	66·7	-	-	-	-	-	-	390 (40)	120
110	105	105	105	-	62·3	-	-	-	-	-	-	-	110
100	95	95	95	-	56·2	-	-	-	-	-	-	-	100
95	90	90	90	-	52·0	-	-	-	-	-	-	-	95
90	86	86	86	-	48·0	-	-	-	-	-	-	-	90
85	81	81	81	-	41·0	-	-	-	-	-	-	-	85

Remark : Bold figure indicates values from Table 1 of ASTM E 140. (SAE-ASM-ASTM combined and adjusted)

Note : (1) Units and Numerical values in brackets () are converted from psi conversion table of JIS Z 8438 with 1MPa = 1N/mm²

(2) Figures in brackets () from table are seldom used and mainly for reference only.

(3) Iron and Steel quoted from JIS hand book

Approximate converted values compared with Rockwell hardness for Steel (1)

Rockwell Scale C hardness	Vickers hardness	Brinell hardness 10 mm ball 3000kgf			Rockwell hardness ⁽²⁾			Rockwell superficial hardness diamond cone penetrator			Shore hardness	Tensile strength (Approx. value) MPa (kgf/mm ²) ⁽¹⁾	Rockwell Scale C hardness
		Standard ball	Hult-gren ball	Tungsten carbide ball	Scale A Load 60kgf Diamond cone penetrator	Scale B Load 100kgf 1/16 inch Ball	Scale D Load 100kgf Diamond cone penetrator	15-N Scale Load 15 kgf	30-N Scale Load 30 kgf	45-N Scale Load 45 kgf			
68	940	-	-	-	85.6	-	76.9	93.2	84.4	75.4	97	-	68
67	900	-	-	-	85.0	-	76.1	92.9	83.6	74.2	95	-	67
66	865	-	-	-	84.5	-	75.4	92.5	82.8	73.3	92	-	66
65	832	-	-	(739)	83.9	-	74.5	92.2	81.9	72.0	91	-	65
64	800	-	-	(722)	83.4	-	73.8	91.8	81.1	71.0	88	-	64
63	772	-	-	(705)	82.8	-	73.0	91.4	80.1	69.9	87	-	63
62	746	-	-	(688)	82.3	-	72.2	91.1	79.3	68.8	85	-	62
61	720	-	-	(670)	81.8	-	71.5	90.7	78.4	67.7	83	-	61
60	697	-	613	(654)	81.2	-	70.7	90.2	77.5	66.6	81	-	60
59	674	-	599	(634)	80.7	-	69.9	89.8	76.6	65.5	80	-	59
58	653	-	587	615	80.1	-	69.2	89.3	75.7	64.3	78	-	58
57	633	-	575	595	79.6	-	68.5	88.9	74.8	63.2	76	-	57
56	613	-	561	577	79.0	-	67.7	88.3	73.9	62.0	75	-	56
55	595	-	546	560	78.5	-	66.9	87.9	73.0	60.9	74	2075 (212)	55
54	577	-	534	543	78.0	-	66.1	87.4	72.0	59.8	72	2015 (205)	54
53	560	-	519	525	77.4	-	65.4	86.9	71.2	58.6	71	1950 (199)	53
52	544	(500)	508	512	76.8	-	64.6	86.4	70.2	57.4	69	1880 (192)	52
51	528	(487)	494	496	76.3	-	63.8	85.9	69.4	56.1	68	1820 (186)	51
50	513	(475)	481	481	75.9	-	63.1	85.5	68.5	55.0	67	1760 (179)	50
49	498	(464)	469	469	75.2	-	62.1	85.0	67.6	53.8	66	1695 (173)	49
48	484	451	455	455	74.7	-	61.4	84.5	66.7	52.5	64	1635 (167)	48
47	471	442	443	443	74.1	-	60.8	83.9	65.8	51.4	63	1580 (161)	47
46	458	432	432	432	73.6	-	60.0	83.5	64.8	50.3	62	1530 (156)	46
45	446	421	421	421	73.1	-	59.2	83.0	64.0	49.0	60	1480 (151)	45
44	434	409	409	409	72.5	-	58.5	82.5	63.1	47.8	58	1435 (146)	44
43	423	400	400	400	72.0	-	57.7	82.0	62.2	46.7	57	1385 (141)	43
42	412	390	390	390	71.5	-	56.9	81.5	61.3	45.5	56	1340 (136)	42
41	402	381	381	381	70.9	-	56.2	80.9	60.4	44.3	55	1295 (132)	41
40	392	371	371	371	70.4	-	55.4	80.4	59.5	43.1	54	1250 (127)	40
39	382	362	362	362	69.9	-	54.6	79.9	58.6	41.9	52	1215 (124)	39
38	372	353	353	353	69.4	-	53.8	79.4	57.7	40.8	51	1180 (120)	38
37	363	344	344	344	68.9	-	53.1	78.8	56.8	39.6	50	1160 (118)	37
36	354	336	336	336	68.4	(109.0)	52.3	78.3	55.9	38.4	49	1115 (114)	36
35	345	327	327	327	67.9	(108.5)	51.5	77.7	55.0	37.2	48	1080 (110)	35
34	336	319	319	319	67.4	(108.0)	50.8	77.2	54.2	36.1	47	1055 (108)	34
33	327	311	311	311	66.8	(107.5)	50.0	76.6	53.3	34.9	46	1025 (105)	33
32	318	301	301	301	66.3	(107.0)	49.2	76.1	52.1	33.7	44	1000 (102)	32
31	310	294	294	294	65.8	(106.0)	48.4	75.6	51.3	32.5	43	980 (100)	31
30	302	286	286	286	65.3	(105.5)	47.7	75.0	50.4	31.3	42	950 (97)	30
29	294	279	279	279	64.7	(104.5)	47.0	74.5	49.5	30.1	41	930 (95)	29

Approximate converted values compared with Rockwell hardness for Steel (1)

Rockwell Scale C hardness	Vickers hardness	Brinell hardness 10 mm ball 3000kgf			Rockwell hardness ⁽²⁾			Rockwell superficial hardness diamond cone penetrator			Shore hardness	Tensile strength (Approx. value) MPa (kgf/mm ²) ⁽¹⁾	Rockwell Scale C hardness
		Standard ball	Hult-gren ball	Tungsten carbide ball	Scale A Load 60kgf Diamond cone penetrator	Scale B Load 100kgf 1/16 inch Ball	Scale D Load 100kgf Diamond cone penetrator	15-N Scale Load 15 kgf	30-N Scale Load 30 kgf	45-N Scale Load 45 kgf			
28	286	271	271	271	64·3	(104·0)	46·1	73·9	48·6	28·9	41	910 (93)	28
27	279	264	264	264	63·8	(103·0)	45·2	73·3	47·7	27·8	40	880 (90)	27
26	272	258	258	258	63·3	(102·5)	44·6	72·8	46·8	26·7	38	860 (88)	26
25	266	253	253	253	62·8	(101·5)	43·8	72·2	45·9	25·5	38	840 (86)	25
24	260	247	247	247	62·4	(101·0)	43·1	71·6	45·0	24·3	37	825 (84)	24
23	254	243	243	243	62·0	100·0	42·1	71·0	44·0	23·1	36	805 (82)	23
22	248	237	237	237	61·5	99·0	41·6	70·5	43·2	22·0	35	785 (80)	22
21	243	231	231	231	61·0	98·5	40·9	69·9	42·3	20·7	35	770 (79)	21
20	238	226	226	226	60·5	97·8	40·1	69·4	41·5	19·6	34	760 (77)	20
(18)	230	219	219	219	-	96·7	-	-	-	-	33	730 (75)	(18)
(16)	222	212	212	212	-	95·5	-	-	-	-	32	705 (72)	(16)
(14)	213	203	203	203	-	93·9	-	-	-	-	31	675 (69)	(14)
(12)	204	194	194	194	-	92·3	-	-	-	-	29	650 (66)	(12)
(10)	196	187	187	187	-	90·7	-	-	-	-	28	620 (63)	(10)
(8)	188	179	179	179	-	89·5	-	-	-	-	27	600 (61)	(8)
(6)	180	171	171	161	-	87·1	-	-	-	-	26	580 (59)	(6)
(4)	173	165	165	165	-	85·5	-	-	-	-	25	550 (56)	(4)
(2)	166	158	158	158	-	83·5	-	-	-	-	24	530 (54)	(2)
(0)	160	152	152	152	-	81·7	-	-	-	-	24	515 (53)	(0)

Note : (1) Units and Numerical values in bracket () is converted from psi conversion table of JIS Z 8438 with 1Mpa = 1N/ mm²

(2) Figures in brackets () from table are seldom used and mainly for reference only.

(3) Iron and Steel quoted from JIS hand book

Commonly used fitting tolerances for bore dimensions

Unit : μm

Dimensions (mm)		B		C		D			E			F			G		H						
Above	Below	B10	C9	C10	D8	D9	D10	E7	E8	E9	F6	F7	F8	G6	G7	H6	H7	H8	H9	H10	H11		
-	3	+180 +140	+85 +60	+100	+34	+45 +20	+60	+24	+28 +14	+39	+12	+16 +6	+20	+8 +2	+12	+6	+10	+14	+25	+40	+60		
3	6	+188 +140	+100 +70	+118	+48	+60 +30	+78	+32	+38 +20	+50	+18	+22 +10	+28	+12 +4	+16	+8	+12	+18	+30	+48	+75		
6	10	+208 +150	+116 +80	+138	+62	+76 +40	+98	+40	+47 +25	+61	+22	+28 +13	+35	+14 +5	+20	+9	+15	+22	+36	+58	+90		
10	14	+220 +150	+138 +95	+165	+77	+93	+120	+50	+59	+75	+27	+34	+43	+17	+24	+11	+18	+27	+43	+70	+110		
14	18																					0	
18	24	+244 +160	+162 +110	+194	+98	+117	+149	+61	+73	+92	+33	+41	+53	+20	+28	+13	+21	+33	+52	+84	+130		
24	30																					0	
30	40	+270 +170	+182 +120	+220	+119	+142	+180	+75	+89	+112	+41	+50	+64	+25	+34	+25	+34	+16	+25	+39	+62	+100	+160
40	50	+280 +180	+192 +130	+230																			
50	65	+310 +190	+214 +140	+260	+146	+174	+220	+90	+106	+134	+49	+60	+76	+29	+40	+19	+30	+46	+74	+120	+190		
65	80	+320 +200	+224 +150	+270																		+100	+60
80	100	+360 +220	+257 +170	+310	+174	+207	+260	+107	+126	+159	+58	+71	+90	+34	+47	+22	+35	+54	+87	+140	+220		
100	120	+380 +240	+267 +180	+320																		+120	+72
120	140	+420 +260	+300 +200	+360	+208	+245	+305	+125	+148	+185	+68	+83	+106	+39	+54	+25	+40	+63	+100	+160	+250		
140	160	+440 +280	+310 +210	+370																		+145	+85
160	180	+470 +310	+330 +230	+390	+242	+285	+355	+146	+172	+215	+79	+96	+122	+44	+61	+29	+46	+72	+115	+185	+290		
180	200	+525 +340	+355 +240	+425																		+170	+100
200	225	+565 +380	+375 +260	+445	+271	+320	+400	+162	+191	+240	+88	+108	+137	+49	+69	+32	+52	+81	+130	+210	+320		
225	250	+605 +420	+395 +280	+465																		+190	+110
250	280	+690 +480	+430 +300	+510	+299	+350	+440	+182	+214	+265	+98	+119	+151	+54	+75	+36	+57	+89	+140	+230	+360		
280	315	+750 +540	+460 +330	+540																		+210	+125
315	355	+830 +600	+500 +360	+590	+327	+385	+480	+198	+232	+290	+108	+131	+165	+60	+83	+40	+63	+97	+155	+250	+400		
355	400	+910 +680	+540 +400	+630																		+230	+135
400	450	+1010 +760	+595 +440	+690	+327	+385	+480	+198	+232	+290	+108	+131	+165	+60	+83	+40	+63	+97	+155	+250	+400		
450	500	+1090 +840	+635 +480	+730																		+230	+135

Remark : For each cell in the table above, values in the top row shows upper limit of tolerance and values in the bottom row shows lower limit of tolerance.

Commonly used fitting tolerances for bore dimensions

Unit : μm

Dimensions (mm)		Js				K		M		N		P		R	S	T	U	X			
Above	Below	Js6	Js7	Js8	Js9	K6	K7	M6	M7	N6	N7	P6	P7	R7	S7	T7	U7	X7			
-	3	± 3	± 5	± 7	± 12.5	0 -6	0 -10	-2 -8	-2 -12	-4 -10	-4 -14	-6 -12	-6 -16	-10 -20	-14 -24	-	-18 -28	-20 -30			
3	6	± 4	± 6	± 9	± 15	+2 -6	+3 -9	-1 -9	0 -12	-5 -13	-4 -16	-9 -17	-8 -20	-11 -23	-15 -27	-	-19 -31	-24 -36			
6	10	± 4.5	± 7.5	± 11	± 18	+2 -7	+5 -10	-3 -12	0 -15	-7 -16	-4 -19	-12 -21	-9 -24	-13 -28	-17 -32	-	-22 -37	-28 -43			
10	14	± 5.5	± 9	± 13.5	± 21.5	+2	+6	-4	0	-9	-5	-15	-11	-16	-21	-	-26	-33			
14	18					-9	-12	-15	-18	-20	-23	-26	-29	-34	-39	-	-44	-51	-56		
18	24	± 6.5	± 10.5	± 16.5	± 26	+2	+6	-4	0	-11	-7	-18	-14	-20	-27	-	-33	-46			
24	30					-11	-15	-17	-21	-24	-28	-31	-35	-41	-48	-	-54	-67			
30	40	± 8	± 12.5	± 19.5	± 31	+3	+7	-4	0	-12	-8	-21	-17	-25	-31	-39	-40	-51			
40	50					-13	-18	-20	-25	-28	-33	-37	-42	-50	-59	-	-64	-76			
50	65	± 9.5	± 15	± 23	± 37	+4	+9	-5	0	-14	-9	-26	-21	-30	-42	-55	-76	-			
65	80					-15	-21	-24	-30	-33	-39	-45	-51	-60	-72	-85	-106				
80	100	± 11	± 17.5	± 27	± 43.5	+4	+10	-6	0	-16	-10	-30	-21	-38	-58	-78	-111	-			
100	120					-18	-25	-28	-35	-38	-45	-52	-59	-73	-93	-113	-146				
120	140	± 12.5	± 20	± 31.5	± 50	+4 -21	+12 -28	-8 -33	0 -40	-20 -45	-12 -52	-36 -61	-28 -68	-48	-77	-107	-	-			
140	160													-88	-117	-147			-50	-85	-119
160	180													-90	-125	-159			-53	-93	-131
180	200	± 14.5	± 23	± 36	± 57.5	+5 -24	+13 -33	-8 -37	0 -46	-22 -51	-14 -60	-41 -70	-33 -79	-60	-105	-	-	-			
200	225													-106	-151	-63			-113		
225	250													-109	-159	-67			-123		
250	280	± 16	± 26	± 40.5	± 65	+5	+16	-9	0	-25	-14	-47	-36	-74	-	-	-	-			
280	315					-27	-36	-41	-52	-57	-66	-79	-88	-126	-78	-130					
315	355	± 18	± 28.5	± 44.5	± 70	+7	+17	-10	0	-26	-16	-51	-41	-87	-	-	-	-			
355	400					-29	-40	-46	-57	-62	-73	-87	-93	-144	-93	-150					
400	450	± 20	± 31.5	± 48.5	± 77.5	+8	+18	-10	0	-27	-17	-55	-45	-103	-	-	-	-			
450	500					-32	-45	-50	-63	-67	-80	-95	-108	-166	-109	-172					

Remark : For each cell in the table above, values in the top row shows upper limit of tolerance and values in the bottom row shows lower limit of tolerance.

Commonly used fitting tolerances for axis dimensions

Unit : μm

Dimensions (mm)		js				k		m		n	p	r	s	t	u	x
Above	Below	js5	js6	js7	js8	k5	k6	m5	m6	n6	p6	r6	s6	t6	u6	x6
-	3	± 2	± 3	± 5	± 7	+4 0	+6	+6 +2	+8	+10 +4	+12 +6	+16 +10	+20 +14	-	+24 +18	+26 +20
3	6	± 2.5	± 4	± 6	± 9	+6 +1	+9	+9 +4	+12	+16 +8	+20 +12	+23 +15	+27 +19	-	+31 +23	+36 +28
6	10	± 3	± 4.5	± 7.5	± 11	+7 +1	+10	+12 +6	+15	+19 +10	+24 +15	+28 +19	+32 +23	-	+37 +28	+43 +34
10	14	± 4	± 5.5	± 9	± 13.5	+9	+12	+15	+18	+23	+29	+34	+39	-	+44	+51
14	18					+1	+7	+12	+18	+23	+28	+33	+40		+45	
18	24	± 4.5	± 6.5	± 10.5	± 16.5	+11	+15	+17	+21	+28	+35	+41	+48	-	+54	+67
24	30					+2	+8	+15	+21	+28	+35	+41	+48	+54	+61	+77
30	40	± 5.5	± 8	± 12.5	± 19.5	+13	+18	+20	+25	+33	+42	+50	+59	+64	+76	-
40	50					+2	+9	+25	+33	+42	+50	+59	+64	+76		
50	65	± 6.5	± 9.5	± 15	± 23	+15	+21	+24	+30	+30	+51	+60	+72	+85	+106	-
65	80					+2	+11	+30	+30	+51	+60	+72	+85	+106		
80	100	± 7.5	± 11	± 17.5	± 27	+18	+25	+28	+35	+45	+59	+73	+93	+113	+146	-
100	120					+3	+13	+35	+45	+59	+73	+93	+113	+146		
120	140	± 9	± 12.5	± 20	± 31.5	+21	+28	+33	+40	+52	+68	+88	+117	+147	-	-
140	160					+3	+15	+40	+52	+68	+88	+117	+147			
160	180					+63	+92	+122	+159	+192	+246	+309	+381			
180	200	± 10	± 14.5	± 23	± 36	+24	+33	+37	+46	+60	+79	+106	+151	+192	-	-
200	225					+4	+17	+46	+60	+79	+106	+151	+192			
225	250					+84	+140	+192	+246	+309	+381	+465	+558			
250	280	± 11.5	± 16	± 26	± 40.5	+27	+36	+43	+52	+66	+88	+126	+171	-	-	-
280	315					+4	+20	+52	+66	+88	+126	+171	+216			
315	355	± 12.5	± 18	± 28.5	± 44.5	+29	+40	+46	+57	+73	+98	+144	+198	-	-	-
355	400					+4	+21	+57	+73	+98	+144	+198	+261			
400	450					+114	+166	+228	+300	+384	+486	+600	+738			
450	500	± 13.5	± 20	± 31.5	± 48.5	+32	+45	+50	+63	+80	+108	+166	+228	-	-	-
500	550					+5	+23	+63	+80	+108	+166	+228	+300			

Remark : For each cell in the table above, values in the top row shows upper limit of tolerance and values in the bottom row shows lower limit of tolerance.

Commonly used fitting tolerances for axis dimensions

Unit : μm

Dimensions (mm)		b	c	d		e			f			g		h						
Above	Below	b9	c9	d8	d9	e7	e8	e9	f6	f7	f8	g5	g6	h5	h6	h7	h8	h9	h10	h11
-	3	-140 -165	-60 -85	-20 -34 -45		-14 -24 -28 -39			-6 -12 -16 -20			-2 -6 -8		0 -4 -6 -10 -14 -25 -40 -60						
3	6	-140 -170	-70 -100	-30 -48 -60		-20 -32 -38 -50			-10 -18 -22 -28			-4 -9 -12		0 -5 -8 -12 -18 -30 -48 -75						
6	10	-150 -186	-80 -116	-40 -62 -76		-25 -40 -47 -61			-13 -22 -28 -35			-5 -11 -14		0 -6 -9 -15 -22 -36 -58 -90						
10	14	-150 -193	-95 -138	-50		-32			-16			-6		0						
14	18			-77 -93	-50 -59 -75	-27 -34 -43	-14 -17	-8 -11 -18 -27 -43 -70 -110												
18	24	-160 -212	-110 -162	-65		-40			-20			-7		0						
24	30			-98 -117	-61 -73 -92	-33 -41 -53	-16 -20	-9 -13 -21 -33 -52 -84 -130												
30	40	-170 -232	-120 -182	-80		-50			-25			-9		0						
40	50	-180 -242	-130 -192	-119 -142	-75 -89 -112	-41 -50 -64	-20 -25	-11 -16 -25 -39 -62 -100 -160												
50	65	-190 -264	-140 -214	-100		-60			-30			-10		0						
65	80	-200 -274	-150 -224	-146 -174	-90 -106 -134	-49 -60 -76	-23 -29	-13 -19 -30 -46 -74 -120 -190												
80	100	-220 -307	-170 -257	-120		-72			-36			-12		0						
100	120	-240 -327	-180 -267	-174 -207	-107 -126 -159	-58 -71 -90	-27 -34	-15 -22 -35 -54 -87 -140 -220												
120	140	-260 -360	-200 -300	-145		-85			-43			-14		0						
140	160	-280 -380	-210 -310	-208 -245	-125 -148 -185	-68 -83 -106	-32 -39	-18 -25 -40 -63 -100 -160 -250												
160	180	-310 -410	-230 -330	-170		-100			-50			-15		0						
180	200	-340 -455	-240 -355	-242 -285	-146 -172 -215	-79 -96 -122	-35 -44	-20 -29 -46 -72 -115 -185 -290												
200	225	-380 -495	-260 -375	-170		-100			-50			-15		0						
225	250	-420 -535	-280 -395	-190		-110			-56			-17		0						
250	280	-480 -610	-300 -430	-271 -320	-162 -191 -240	-88 -108 -137	-40 -49	-23 -32 -52 -81 -130 -210 -320												
280	315	-540 -670	-330 -460	-210		-125			-62			-18		0						
315	355	-600 -710	-360 -500	-299 -350	-182 -214 -265	-98 -119 -151	-43 -54	-25 -36 -57 -89 -140 -230 -260												
355	400	-680 -820	-400 -540	-230		-135			-68			-20		0						
400	450	-760 -915	-440 -595	-327 -385	-198 -232 -290	-108 -131 -165	-47 -60	-27 -40 -63 -97 -155 -250 -400												
450	500	-840 -995	-480 -635	-230		-135			-68			-20		0						

Remark : For each cell in the table above, values in the top row shows upper limit of tolerance and values in the bottom row shows lower limit of tolerance.

Metric coarse and Fine screw threads

Extracted from JIS B0205, 0207

Nominal threads	Pitch P			
	Coarse screw	Fine screw		
M1	0.25	0.2		
M1.1	0.25	0.2		
M1.2	0.25	0.2		
M1.4	0.3	0.2		
M1.6	0.35	0.2		
M1.8	0.35	0.2		
M2	0.4	0.25		
M2.2	0.45	0.25		
M2.5	0.45	0.35		
M3	0.5	0.35		
M3.5	0.6	0.35		
M4	0.7	0.5		
M4.5	0.75	0.5		
M5	0.8	0.5		
M6	1	0.75		
M8	1.25	0.75	1	
M10	1.5	0.75	1	1.25
M12	1.75	1	1.25	1.5
M14	2	1	1.25	1.5
M16	2	1	1.5	1.5
M18	2.5	1	1.5	2
M20	2.5	1	1.5	2
M22	2.5	1	1.5	2
M24	3	1	1.5	2
M27	3	1	1.5	2
M30	3.5	1	1.5	2

Following details are for reference only and not part of JIS standard.

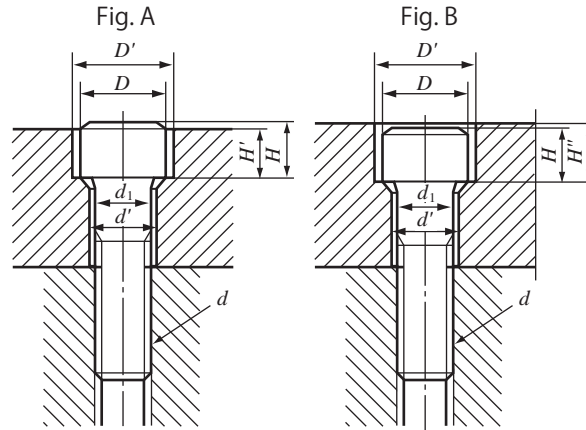

Spot facing and Thread hole for Hexagon socket head cap screws

Unit: mm

Nominal thread (d)	M3	M4	M5	M6	M8	M10	M12	M14	M16	M18	M20	M22	M24	M27	M30	M33	M36	M39	M42	M45	M48	M52
d_1	3	4	5	6	8	10	12	14	16	18	20	22	24	27	30	33	36	39	42	45	48	52
d'	3.4	4.5	5.5	6.6	9	11	14	16	18	20	22	24	26	30	33	36	39	42	45	48	52	56
D	5.5	7	8.5	10	13	16	18	21	24	27	30	33	36	40	45	50	54	58	63	68	72	78
D'	6.5	8	9.5	11	14	17.5	20	23	26	29	32	35	39	43	48	54	58	62	67	72	76	82
H	3	4	5	6	8	10	12	14	16	18	20	22	24	27	30	33	36	39	42	45	48	52
H'	2.7	3.6	4.6	5.5	7.4	9.2	11	12.8	14.5	16.5	18.5	20.5	22.5	25	28	31	34	37	39	42	45	49
H''	3.3	4.4	5.4	6.5	8.6	10.8	13	15.2	17.5	19.5	21.5	23.5	25.5	29	32	35	38	41	44	47	50	54

Remark: Thread holes (d') provide Class 2 from JIS B 1001 (Thread holes and Spot facing holes)

Parallel key and Key Way

Dimensions and tolerances for KG-gear with Key way are equivalent to JIS B1301.

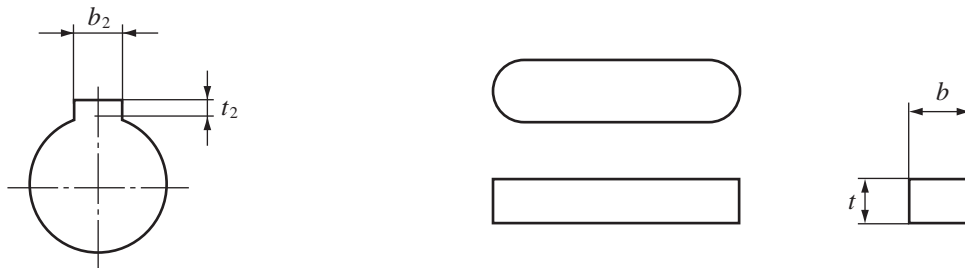

Tolerances for Key

$b \times t$	3 × 3	4 × 4	5 × 5	6 × 6	8 × 7	10 × 8	12 × 8	14 × 9
b Tolerance (h)	h9	h9	h9	h9	h9	h9	h9	h9
t Tolerance (h)	h9	h9	h9	h9	h11	h11	h11	h11

Key way for KG-STOCK GEARS

Unit : mm

Dimensions	Bore dimensions	Key way $b_2 \times t_2$	Width		Depth	
			b_2	Tolerance Js 9	t_2	Tolerance
$\phi 8 \sim \phi 10$	$\phi 8$	3 × 1.4	3	± 0.0125	1.4	$\begin{matrix} +0.1 \\ 0 \end{matrix}$
	$\phi 10$					
$\phi 10 \sim \phi 12$	$\phi 12$	4 × 1.8	4	± 0.015	1.8	
	$\phi 12 \sim \phi 17$				$\phi 14$	
$\phi 15$						
$\phi 17 \sim \phi 22$	$\phi 16$	6 × 2.8	6	± 0.015	2.8	
	$\phi 18$					
	$\phi 20$					
$\phi 22 \sim \phi 30$	$\phi 22$	8 × 3.3	8	± 0.018	3.3	
	$\phi 25$					
	$\phi 28$					
$\phi 30 \sim \phi 38$	$\phi 30$	10 × 3.3	10	± 0.0215	3.3	$\begin{matrix} +0.2 \\ 0 \end{matrix}$
	$\phi 32$					
$\phi 38 \sim \phi 44$	$\phi 35$	12 × 3.3	12	± 0.0215	3.3	
	$\phi 40$					
$\phi 44 \sim \phi 50$	$\phi 45$	14 × 3.8	14	± 0.0215	3.8	
	$\phi 50$					

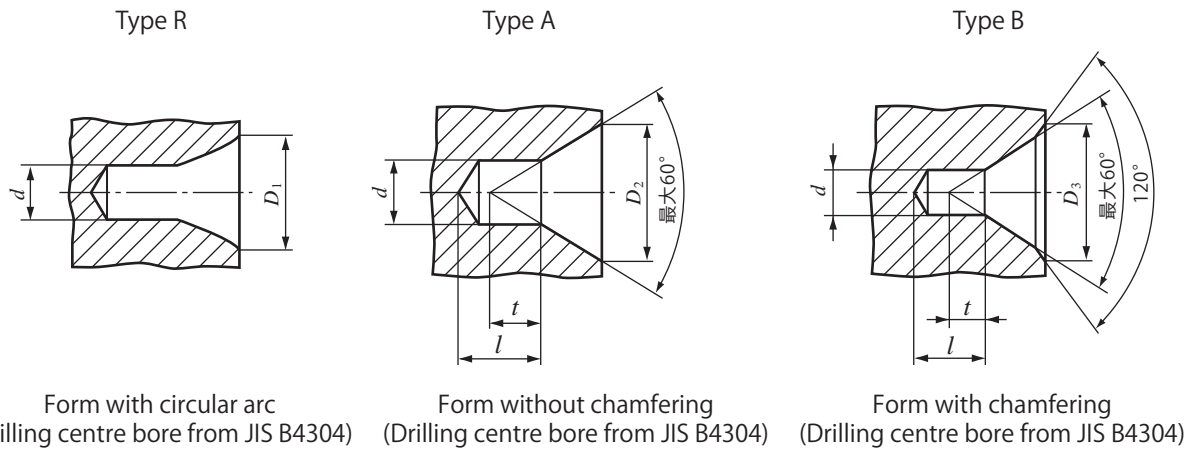

Note* : Length 'l' is based on centre drill but length must be longer than dimension 't'.

Centre bore (recommended)

Unit : mm

Nominal <i>d</i>	Type				
	Type R JIS B4304	Type A JIS B4304		Type B JIS B4304	
	<i>D</i> ₁ Nominal	<i>D</i> ₂ Nominal	<i>t</i> Reference	<i>D</i> ₃ Nominal	<i>t</i> Reference
(0.5)		1.06	0.5		
(0.63)		1.32	0.6		
(0.8)		1.70	0.7		
1.0	2.12	2.12	0.9	3.15	0.9
(1.25)	2.65	2.65	1.1	4	1.1
1.6	3.35	3.35	1.4	5	1.4
2.0	4.25	4.25	1.8	6.3	1.8
2.5	5.3	5.30	2.2	8	2.2
3.15	6.7	6.70	2.8	10	2.8
4.0	8.5	8.50	3.5	12.5	3.5
(5.0)	10.6	10.60	4.4	16	4.4
6.3	13.2	13.20	5.5	18	5.5
(8.0)	17.0	17.00	7.0	22.4	7.0
10.0	21.2	21.20	8.7	28	8.7

Using figures in bracket () is not advisable.

Memo

KG GEAR'S WORLD WIDE NETWORK

SINGAPORE

TRIPOD TRADING PTE LTD.
10 Dickson Road, Singapore 209498
TEL 65 – 62950933
FAX 65 – 62950233
e-mail tripod@cyberway.com.sg

HAKURUMA TECNOLOGY PTE LTD.
No.48, Toh Guan Road East, #05-101
Enterprise Hub Singapore 608586
TEL 65 – 65478542
FAX 65 – 68489523
http://www.hakuruma.com
e-mail hakuruma@sigmet.com.sg

MALAYSIA

**LETROMECH INDUSTRIES (M) SDN.
BHD.**
33, Persiaran Mahsuri 1/1, Sunway Tunas,
11900 Penang, Malaysia
TEL 60 – 4 – 6443741
FAX 60 – 4 – 6443749
http://www.letromec.com
e-mail ltleee@pc.jaring.my

THAILAND

EXIM & MFG (THAILAND) CO., LTD.
111/12 Moo 3, B-Avenue Tiwanon-Changwattana Rd.,
Banmai, Muang Pathumthani 12000, Thailand
TEL 66 – 2 – 501 – 1507/1508 ext 108
FAX 66 – 2 – 501 – 1509
http://www.eximfr.com.sg
e-mail parinya@eximfr.com.sg

TAIWAN

YUNG HO COMPANY LTD.
5F. No.36 Kuan Chien Rd, Taipei 100 Taiwan, R.O.C.
TEL 886 – 2 – 2311-6561
FAX 886 – 2 – 2311-6469
e-mail shyungho@ms.hinet

KOREA

SAMSUNG KI KONG
1025-4 Chimsan 1-dong, Buk-Gu, Daegu 702-862, Korea
TEL 82 – 53 – 351 – 4700
FAX 82 – 53 – 351 – 8383
http://www.ssgg.co.kr
e-mail ssgg@ssgg.co.kr

USA

STOCK DRIVE PRODUCTS
2101 Jericho Turnpike, Box 5416, New Hyde Park, NY 11042-5416
TEL 1 – 516 – 328 – 3300
FAX 1 – 516 – 326 – 8827
http://www.sdp-si.com
e-mail support@sdp-si.com

UNITED KINGDOM

**RELIANCE PRECISION
MECHATRONICS**
Rowley Mills Lepton Huddersfield
England HD8 0LE
TEL 44 – 0 – 1484 – 601002
FAX 44 – 0 – 1484 – 601061
http://www.reliance.co.uk
e-mail sales@rpmechatronics.co.uk

Reliance Holland
e-mail jb@reliance.co.uk

Reliance France
e-mail ph@reliance.co.uk

CHINA

**HAKURUMA TECHNOLOGY (Shanghai)
Co., Ltd**
Room 1202, No. 79 AoNa Road Pudong
Free Trade Zone Shanghai PC, 200131
China.
TEL 86 – 021 – 61553869
FAX 86 – 021 – 51062026
http://www.hakuruma.com
e-mail hakurumachina@hotmail.com

FUJIKAWA DENDOKI(Shanghai)CO.,LTD.
Room 311, Block D, Shang-Mira Commercial
Center, 2633 Yan'an West Road Changning,
Shanghai, China PC; 200336
TEL 86 – 021 – 3255-8350
FAX 86 – 021 – 3255-8357
http://www.f-d.co.jp
e-mail skan@f-d.co.jp

2015年6月1日 初版発行
2015年9月1日 第二版発行
2016年11月14日 第三版発行

Printed : 3rd NOV 2016

編集・発行／協育歯車工業株式会社

URL <http://www.kggear.co.jp/>

本社 〒110-0015 東京都台東区東上野 1-8-3
管理部 電話(03)3831-8238(代) FAX(03)3835-2877
営業部 〒344-0057 埼玉県春日部市南栄町 14-9-13
電話(048)754-5842 FAX(048)754-1299
大阪支店 〒541-0057 大阪府大阪市中央区北久宝寺町
1-4-15 SC 堺筋本町ビル 9階
電話(06)4705-8177(代) FAX(06)4705-8188
名古屋支店 〒456-0053 名古屋市熱田区一番 2-24-9
電話(052)652-7211(代) FAX(052)652-7213
春日部工場 〒344-0057 埼玉県春日部市南栄町 14-9-13
電話(048)754-5842 FAX(048)754-1299
技術 電話(048)763-4905(ダイヤルイン)
シンガポール支店
BLK 808 French Road, #07-163,
Kitchener Complex, Singapore 200808
TEL : 65-62996494
FAX : 65-62995405

KYOUIKU GEAR MFG. CO., LTD.

URL <http://www.kggear.co.jp/english>

Head Office

1-8-3, Higashi-ueno Taito-ku Tokyo Japan
TEL81-3-3831-8238 FAX81-3-3835-2877

Sales Department and factory

14-9-13, Minami-sakae Kasukabe-city Saitama Japan
TEL81-48-754-5842 FAX81-48-754-1299

Osaka branch

541-0057, 9F Sakaisuji Honmachi Bld Kita-kyuhouji
Chuo-ku Osaka-city Osaka Japan
TEL81-6-4705-8177 FAX81-6-4705-8188

Nagoya branch

2-24-9, Ichiban Atsuta-ku Nagoya-city Aichi Japan
TEL81-52-652-7211 FAX81-52-652-7213

Singapore branch

BLK 808 French Road, #07-163, Kitchener Complex,
Singapore 200808
TEL65-62996494 FAX65-62995405

制作／全研本社株式会社



ISO 9001 : 2008 認証取得
Certificates obtained
ISO14001 : 2004 認証取得(春日部工場)
Certificates obtained
(Kasukabe factory)



KYOUIKU GEAR MFG.CO.,LTD.

取扱店