

マイタギヤ

MITER GEARS

モジュール **1.5**
MODULE

圧力角 20° 歯数比 1:1
1:1 Ratio 20° PRESSURE ANGLE

JIS B1704 3級 (歯部高周波焼入品:4級)
System of Accuracy: JIS B 1704 Class 3
(Induction hardened products: Class 4)



New 仕様変更 締結加工不要。
Additional machining on tightening is not necessary.

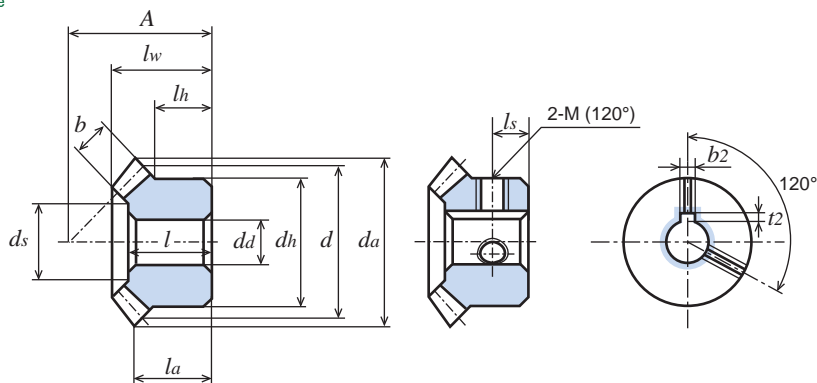

S45C 機械構造用炭素鋼 (JIS G 4051)

Material: Carbon Steel (ISO C45)

単位: mm
Dimensions: mm

商品記号 Catalogue Number	歯数比 Ratio	歯数 Number of Teeth	基準円直径 Reference Diameter	歯先円直径 Tip Diameter	組立距離 Locating Distance	穴径 Bore Diameter	ハブ外径 Hub Diameter	ハブ長さ Hub Projection	穴長さ Bore Length	全長 Overall Length	歯幅 Face Width	ねじ Set Screw	歯先角 Face Angle	重量 Weight		
															ねじ	歯先角
												2-M	ls	da	ds	W(g)
M1.5S 20 - 2810	1	20	φ30	φ32.12	28	φ10	φ24	10	16.5	18.53	14.06	-	49° 3'	φ17.7	54.9	
M1.5S 20 - 2810H	1	20	φ30	φ32.12	28	φ10(H8)	φ24	10	16.5	18.53	14.06	-	49° 3'	φ17.7	54.9	
M1.5S 20 # 2810H	1	20	φ30	φ32.12	28	φ10(H8)	φ24	10	16.5	18.53	14.06	3 × 1.4	2-M4 5	49° 3'	φ17.7	53.7
M1.5S 20 # 2812H	1	20	φ30	φ32.12	28	φ12(H8)	φ24	10	16.5	18.53	14.06	4 × 1.8	2-M4 5	49° 3'	φ17.7	49.0
M1.5S 20 - 2110	1	20	φ30	φ32.12	21	φ10	φ24	3	9	11	7.06	-	49° 3'	φ19.0	32.8	
M1.5S 20 - 2110H	1	20	φ30	φ32.12	21	φ10(H8)	φ24	3	9	11	7.06	-	49° 3'	φ19.0	32.8	
M1.5S 20 = 2110H	1	20	φ30	φ32.12	21	φ10(H8)	φ24	3	9	11	7.06	3 × 1.4	-	49° 3'	φ19.0	32.5
M1.5S 25 - 3410	1	25	φ37.5	φ39.62	34	φ10	φ30	11.5	19	21.26	16.31	-	48° 51'	φ23.7	106.5	
M1.5S 25 - 3410H	1	25	φ37.5	φ39.62	34	φ10(H8)	φ30	11.5	19	21.26	16.31	-	48° 51'	φ23.7	106.5	

カタログ記号の末尾に【H】を付した商品は歯部高周波焼入済です。【H】: Gear tooth surface completed with induction hardening, Hardness HRC 47 to 53.
【#】(シャープ)にはキー材とセットスクリューが付いております。【#】: Gear with key way and threaded hole / with key and screw.

許容伝達動力表 (W) 曲げ強さ

Allowable transfer capability table (W) Bending Strength

商品記号 Catalogue Numbers	回転速度 (min ⁻¹) revolution/min						
	10	100	200	400	600	800	1,000
M1.5S 20 - 2810	3.7	37.1	74.4	148.9	223.3	287.6	344.7
M1.5S 20 - 2810H	3.4	34.4	68.9	137.8	206.7	267.0	321.6
M1.5S 20 - 2110	3.3	33.5	67.0	134.1	201.1	259.2	310.8
M1.5S 20 - 2110H	3.1	31.7	63.5	127.0	190.5	246.2	296.4
M1.5S 25 - 3410	5.6	56.5	113.1	226.3	331.5	419.3	499.1
M1.5S 25 - 3410H	5.3	53.6	107.2	214.4	314.6	400.3	478.5

The above references are JGMA standard.

動力の換算式はP26をご参照ください。Please refer to the conversion formulas of power on page P26.

許容伝達動力表 (W) 歯面強さ

Allowable transfer capability table (W) Surface Durability

商品記号 Catalogue Numbers	回転速度 (min ⁻¹) revolution/min						
	10	100	200	400	600	800	1,000
M1.5S 20 - 2810	0.2	2.8	5.7	11.7	18.1	23.4	27.6
M1.5S 20 - 2810H	0.7	8.0	16.5	34.0	52.0	68.0	82.8
M1.5S 20 - 2110	0.2	2.6	5.3	10.6	15.5	20.8	25.1
M1.5S 20 - 2110H	0.6	7.4	15.2	31.4	48.0	62.8	76.4
M1.5S 25 - 3410	0.5	5.1	10.5	21.3	31.4	40.2	48.4
M1.5S 25 - 3410H	1.3	14.7	30.4	62.7	93.6	120.6	145.6

JIS B1704 3級 (歯部高周波焼入品: 4級)
System of Accuracy: JIS B 1704 Class 3
(Induction hardened products: Class 4)



御注文には必ず“フルネームで商品記号”を明記してください。
Please refer to the catalogue reference while ordering.
 d_s の寸法は参考値です。
Dimension of d_s is for reference only.

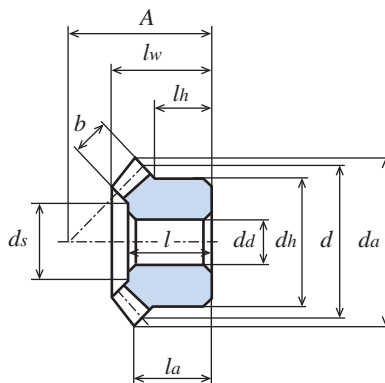

S45C 機械構造用炭素鋼 (JIS G 4051)

Material: Carbon Steel (ISO C45)

単位: mm
Dimensions: mm

商品記号 Catalogue Number	歯数比 Ratio u	歯数 Number of Teeth z	基準円直径 Reference Diameter d	歯先円直径 Tip Diameter d_a	組立距離 Locating Distance A	穴径 Bore Diameter $d_d(H7)$	ハブ外径 Hub Diameter d_h	ハブ長さ Hub Projection l_h	穴長さ Bore Length l	全長 Overall Length l_w	Tip Distance l_a	歯幅 Face Width b	キミぞ Key Way $b_2 \times t_2$	ねじ Set Screw		歯先角 Face Angle δ_a	d_s	重量 Weight $W(g)$
														2-M	l_s			
M1.5S 30 - 3812	1	30	$\phi 45$	$\phi 47.12$	38	$\phi 12$	$\phi 33$	12.34	21	22.83	16.56	9.3	-	-	-	47°42'	$\phi 29.6$	152.0
M1.5S 30 - 3812H	1	30	$\phi 45$	$\phi 47.12$	38	$\phi 12(H8)$	$\phi 33$	12.34	21	22.83	16.56	9.3	-	-	-	47°42'	$\phi 29.6$	152.0
M1.5S 30 # 3812H	1	30	$\phi 45$	$\phi 47.12$	38	$\phi 12(H8)$	$\phi 33$	12.34	21	22.83	16.56	9.3	4 × 1.8	2-M4	6.5	47°42'	$\phi 29.6$	150.1
M1.5S 30 # 3815H	1	30	$\phi 45$	$\phi 47.12$	38	$\phi 15(H8)$	$\phi 33$	12.34	21	22.83	16.56	9.3	5 × 2.3	2-M4	6.5	47°42'	$\phi 29.6$	139.0
M1.5S 30 # 3816H	1	30	$\phi 45$	$\phi 47.12$	38	$\phi 16(H8)$	$\phi 33$	12.34	21	22.83	16.56	9.3	5 × 2.3	2-M4	6.5	47°42'	$\phi 29.6$	135.0

カタログ記号の末尾に【H】を付した商品は歯部高周波焼入済です。[H]: Gear tooth surface completed with induction hardening, Hardness HRC 47 to 53.
【#】(シャープ)にはキー材とセットスクリューが付いております。[#]: Gear with key way and threaded hole / with key and screw.

許容伝達動力表 (W) 曲げ強さ

Allowable transfer capability table (W) Bending Strength

商品記号 Catalogue Numbers	回転速度 (min ⁻¹) revolution/min						
	10	100	200	400	600	800	1,000
M1.5S 30 - 3812	8.8	88.3	176.7	353.5	501.8	630.0	744.7
M1.5S 30 - 3812H	8.3	83.2	166.5	333.1	475.1	599.9	712.1

The above references are JGMA standard.

動力の換算式は P26 をご参照ください。Please refer to the conversion formulas of power on page P26.

許容伝達動力表 (W) 歯面強さ

Allowable transfer capability table (W) Surface Durability

商品記号 Catalogue Numbers	回転速度 (min ⁻¹) revolution/min						
	10	100	200	400	600	800	1,000
M1.5S 30 - 3812	0.9	9.5	19.1	38.7	55.6	70.7	84.4
M1.5S 30 - 3812H	2.3	26.4	54.5	112.5	163.3	208.9	250.4

マイタギヤ

MITER GEARS

モジュール **2**
MODULE

圧力角 20° 歯数比 1:1
1:1 Ratio 20° PRESSURE ANGLE

JIS B1704 3級 (歯部高周波焼入品: 4級)
System of Accuracy: JIS B 1704 Class 3
(Induction hardened products: Class 4)



仕様変更 締結加工不要。
Additional machining on tightening is not necessary.

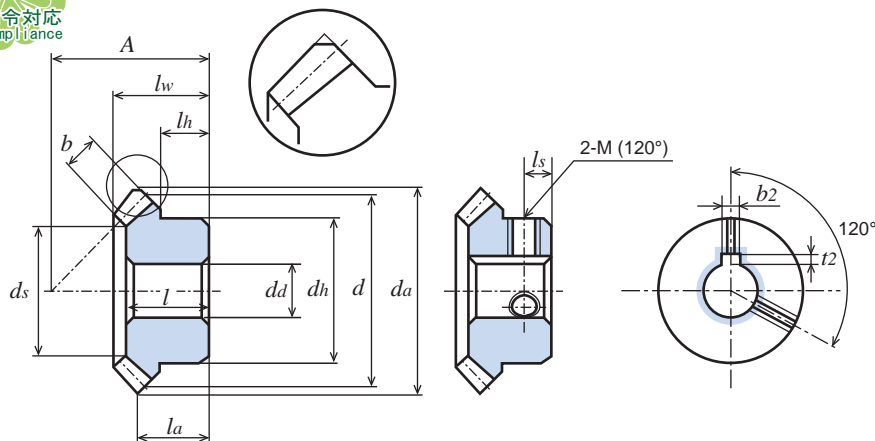

S45C 機械構造用炭素鋼 (JIS G 4051)
Material: Carbon Steel (ISO C45)

単位: mm
Dimensions: mm

商品記号 Catalogue Number	歯数比 Ratio	歯数 Number of Teeth	基準円直径 Reference Diameter	歯先円直径 Tip Diameter	組立距離 Locating Distance	穴径 Bore Diameter	ハブ外径 Hub Diameter	ハブ長さ Hub Projection	穴長さ Bore Length	全長 Overall Length	全長 Overall Length	歯幅 Face Width	キミぞ Key Way	ねじ Set Screw		歯先角 Face Angle	歯先角 Face Angle	重量 Weight
														2-M	ls			
M2S 20 - 3712	1	20	φ40	^(φ42.83) φ41.32	37	φ12	φ34	14	21	24	18.41	8.5	-	-	-	49° 3'	φ23.9	141.0
M2S 20 - 3712H	1	20	φ40	^(φ42.83) φ41.32	37	φ12(H8)	φ34	14	21	24	18.41	8.5	-	-	-	49° 3'	φ23.9	141.0
M2S 20 # 3712H	1	20	φ40	^(φ42.83) φ41.32	37	φ12(H8)	φ34	14	21	24	18.41	8.5	4 × 1.8	2-M5	7	49° 3'	φ23.9	138.4
M2S 20 # 3715H	1	20	φ40	^(φ42.83) φ41.32	37	φ15(H8)	φ34	14	21	24	18.41	8.5	5 × 2.3	2-M5	7	49° 3'	φ23.9	127.4
M2S 20 # 3716H	1	20	φ40	^(φ42.83) φ41.32	37	φ16(H8)	φ34	14	21	24	18.41	8.5	5 × 2.3	2-M5	7	49° 3'	φ23.9	123.5
M2S 20 - 2812	1	20	φ40	^(φ42.83) φ41.32	28	φ12	φ34	5	12	15	9.41	8.5	-	-	-	49° 3'	φ23.9	84.9
M2S 20 - 2812H	1	20	φ40	^(φ42.83) φ41.32	28	φ12(H8)	φ34	5	12	15	9.41	8.5	-	-	-	49° 3'	φ23.9	84.9
M2S 20 = 2812H	1	20	φ40	^(φ42.83) φ41.32	28	φ12(H8)	φ34	5	12	15	9.41	8.5	4 × 1.8	-	-	49° 3'	φ23.9	84.2
M2S 20 = 2815H	1	20	φ40	^(φ42.83) φ41.32	28	φ15(H8)	φ34	5	12	15	9.41	8.5	5 × 2.3	-	-	49° 3'	φ23.9	77.8
M2S 20 = 2816H	1	20	φ40	^(φ42.83) φ41.32	28	φ16(H8)	φ34	5	12	15	9.41	8.5	5 × 2.3	-	-	49° 3'	φ23.9	75.5
M2S 25 - 4012	1	25	φ50	^(φ52.83) φ51.33	40	φ12	φ42	10.99	21	23.34	16.41	10.5	-	-	-	48° 51'	φ32.3	227.0
M2S 25 - 4012H	1	25	φ50	^(φ52.83) φ51.33	40	φ12(H8)	φ42	10.99	21	23.34	16.41	10.5	-	-	-	48° 51'	φ32.3	227.0

カタログ記号の末尾に【H】を付した商品は歯部高周波焼入済です。【H】: Gear tooth surface completed with induction hardening, Hardness HRC 47 to 53.
【#】(シャープ)にはキー材とセットスクリューが付いております。【#】: Gear with key way and threaded hole / with key and screw.

許容伝達動力表 (kW) 曲げ強さ

Allowable transfer capability table (kW) Bending Strength

商品記号 Catalogue Numbers	回転速度 (min ⁻¹) revolution/min						
	10	100	200	400	600	800	1,000
M2S 20 - 3712	0.008	0.083	0.167	0.334	0.484	0.611	0.726
M2S 20 - 3712H	0.007	0.078	0.156	0.313	0.455	0.578	0.689
M2S 25 - 4012	0.013	0.139	0.279	0.554	0.777	0.971	1.143
M2S 25 - 4012H	0.013	0.131	0.262	0.522	0.735	0.923	1.091

The above references are JGMA standard.

動力の換算式は P26 をご参照ください。Please refer to the conversion formulas of power on page P26.

許容伝達動力表 (kW) 歯面強さ

Allowable transfer capability table (kW) Surface Durability

商品記号 Catalogue Numbers	回転速度 (min ⁻¹) revolution/min						
	10	100	200	400	600	800	1,000
M2S 20 - 3712	0.001	0.006	0.013	0.027	0.040	0.051	0.061
M2S 20 - 3712H	0.001	0.018	0.038	0.079	0.117	0.151	0.182
M2S 25 - 4012	0.001	0.013	0.026	0.054	0.076	0.097	0.115
M2S 25 - 4012H	0.003	0.037	0.076	0.156	0.224	0.285	0.340

JIS B1704 3級 (歯部高周波焼入品 : 4級)
System of Accuracy : JIS B 1704 Class 3
(Induction hardened products : Class 4)



御注文には必ず“フルネームで商品記号”を明記してください。
Please refer to the catalogue reference while ordering.
 d_s の寸法は参考値です。
Dimension of d_s is for reference only.

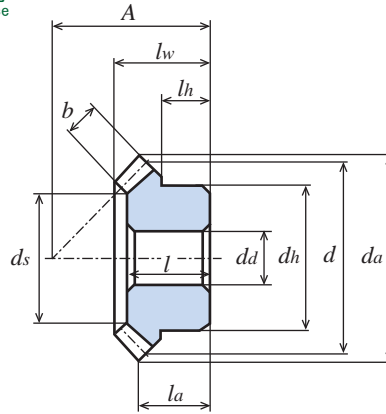

S45C 機械構造用炭素鋼 (JIS G 4051)

Material : Carbon Steel (ISO C45)

単位 : mm
Dimensions : mm

商品記号 Catalogue Number	歯数比 Ratio u	歯数 Number of Teeth z	基準円直径 Reference Diameter d	歯先円直径 Tip Diameter d_a	組立距離 Locating Distance A	穴径 Bore Diameter $d_d(H7)$	ハブ外径 Hub Diameter d_h	ハブ長さ Hub Projection l_h	穴長さ Bore Length l	全長 Overall Length l_w	Tip Distance l_a	歯幅 Face Width b	キーマ みぞ Key Way $b_2 \times t_2$	ねじ Set Screw		歯先角 Face Angle δ_a	d_s	重量 Weight $W(g)$
														2-M	l_s			
M2S 30 - 5116	1	30	$\phi 60$	$\phi 61.36^{(\phi 62.83)}$	51	$\phi 16$	$\phi 44$	16.79	28	30.77	22.41	12.4	-	-	-	47°42'	$\phi 38.9$	361.4
M2S 30 - 5116H	1	30	$\phi 60$	$\phi 61.36^{(\phi 62.83)}$	51	$\phi 16(H8)$	$\phi 44$	16.79	28	30.77	22.41	12.4	-	-	-	47°42'	$\phi 38.9$	361.4
M2S 30 # 5118H	1	30	$\phi 60$	$\phi 61.36^{(\phi 62.83)}$	51	$\phi 18(H8)$	$\phi 44$	16.79	28	30.77	22.41	12.4	6 × 2.8	2-M5	8.5	47°42'	$\phi 38.9$	344.4
M2S 30 # 5120H	1	30	$\phi 60$	$\phi 61.36^{(\phi 62.83)}$	51	$\phi 20(H8)$	$\phi 44$	16.79	28	30.77	22.41	12.4	6 × 2.8	2-M5	8.5	47°42'	$\phi 38.9$	333.3

カタログ記号の末尾に【H】を付した商品は歯部高周波焼入済です。【H】: Gear tooth surface completed with induction hardening, Hardness HRC 47 to 53.
【#】(シャープ)にはキーマ材とセットスクリューが付いております。【#】: Gear with key way and threaded hole / with key and screw.

歯先円直径 d_a の () 内は理論値です。最大外径は軸心と平行に面取りしてありますので、理論値より小さくなっています。

The numeric indicated in the bracket () under the column. Outside diameter d_a has been machined flat. With this process, the outer diameter is smaller than the theory with respect to shaft center to parallel.

許容伝達動力表 (kW) 曲げ強さ

Allowable transfer capability table (kW) Bending Strength

商品記号 Catalogue Numbers	回転速度 (min ⁻¹) revolution/min						
	10	100	200	400	600	800	1,000
M2S 30 - 5116	0.020	0.209	0.418	0.809	1.121	1.388	1.637
M2S 30 - 5116H	0.019	0.197	0.394	0.765	1.066	1.328	1.564

The above references are JGMA standard.

動力の換算式は P26 をご参照ください。Please refer to the conversion formulas of power on page P26.

許容伝達動力表 (kW) 歯面強さ

Allowable transfer capability table (kW) Surface Durability

商品記号 Catalogue Numbers	回転速度 (min ⁻¹) revolution/min						
	10	100	200	400	600	800	1,000
M2S 30 - 5116	0.002	0.023	0.047	0.092	0.129	0.163	0.195
M2S 30 - 5116H	0.005	0.064	0.132	0.265	0.376	0.474	0.564

マイタギヤ

MITER GEARS

モジュール **2.5**
MODULE

圧力角 20° 歯数比 1 : 1
1 : 1 Ratio 20° PRESSURE ANGLE

JIS B1704 3級 (歯部高周波焼入品: 4級)
System of Accuracy: JIS B 1704 Class 3
(Induction hardened products: Class 4)



New 仕様変更 締結加工不要。
Additional machining on tightening is not necessary.

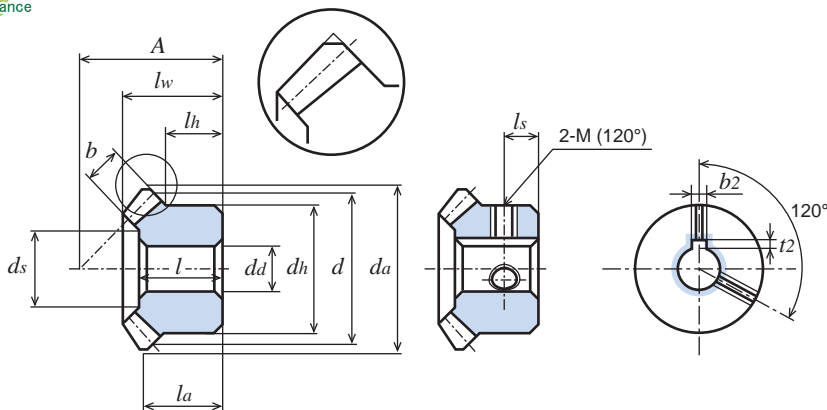

S45C 機械構造用炭素鋼 (JIS G 4051)
Material: Carbon Steel (ISO C45)

単位: mm
Dimensions: mm

商品記号 Catalogue Number	歯数比 Ratio <i>u</i>	歯数 Number of Teeth <i>z</i>	基準円直径 Reference Diameter <i>d</i>	歯先円直径 Tip Diameter <i>da</i>	組立距離 Locating Distance <i>A</i>	穴径 Bore Diameter <i>da(H7)</i>	ハブ外径 Hub Diameter <i>dh</i>	ハブ長さ Hub Projection <i>li</i>	穴長さ Bore Length <i>l</i>	全長 Overall Length <i>lw</i>	全長 Overall Length <i>la</i>	歯幅 Face Width <i>b</i>	キミぞ Key Way <i>b2 × t2</i>	ねじ Set Screw		歯先角 Face Angle <i>δa</i>	歯先角 Face Angle <i>ds</i>	重量 Weight <i>W(g)</i>
														2-M	ls			
M2.5S 20 - 4814	1	20	φ50	^(φ53.54) φ51.66	48	φ14	φ42	19	28	32.06	24.77	11.1	-	-	-	49° 3'	φ28.5	294.0
M2.5S 20 - 4814H	1	20	φ50	^(φ53.54) φ51.66	48	φ14(H8)	φ42	19	28	32.06	24.77	11.1	-	-	-	49° 3'	φ28.5	294.0
M2.5S 20 # 4815H	1	20	φ50	^(φ53.54) φ51.66	48	φ15(H8)	φ42	19	28	32.06	24.77	11.1	5 × 2.3	2-M5	9.5	49° 3'	φ28.5	284.7
M2.5S 20 # 4816H	1	20	φ50	^(φ53.54) φ51.66	48	φ16(H8)	φ42	19	28	32.06	24.77	11.1	5 × 2.3	2-M5	9.5	49° 3'	φ28.5	279.5
M2.5S 20 # 4818H	1	20	φ50	^(φ53.54) φ51.66	48	φ18(H8)	φ42	19	28	32.06	24.77	11.1	6 × 2.8	2-M5	9.5	49° 3'	φ28.5	266.7
M2.5S 20 # 4820H	1	20	φ50	^(φ53.54) φ51.66	48	φ20(H8)	φ42	19	28	32.06	24.77	11.1	6 × 2.8	2-M5	9.5	49° 3'	φ28.5	253.7
M2.5S 20 - 3514	1	20	φ50	^(φ53.54) φ51.66	35	φ14	φ42	6	15	19.06	11.77	11.1	-	-	-	49° 3'	φ28.5	168.3
M2.5S 20 - 3514H	1	20	φ50	^(φ53.54) φ51.66	35	φ14(H8)	φ42	6	15	19.06	11.77	11.1	-	-	-	49° 3'	φ28.5	168.3
M2.5S 20 = 3515H	1	20	φ50	^(φ53.54) φ51.66	35	φ15(H8)	φ42	6	15	19.06	11.77	11.1	5 × 2.3	-	-	49° 3'	φ28.5	164.3
M2.5S 20 = 3518H	1	20	φ50	^(φ53.54) φ51.66	35	φ18(H8)	φ42	6	15	19.06	11.77	11.1	6 × 2.8	-	-	49° 3'	φ28.5	154.5
M2.5S 20 = 3520H	1	20	φ50	^(φ53.54) φ51.66	35	φ20(H8)	φ42	6	15	19.06	11.77	11.1	6 × 2.8	-	-	49° 3'	φ28.5	147.5
M2.5S 25 - 5016	1	25	φ62.5	^(φ66.04) φ64.16	50	φ16	φ52	13.5	27	29.42	20.52	13.5	-	-	-	48° 51'	φ40.8	441.2
M2.5S 25 - 5016H	1	25	φ62.5	^(φ66.04) φ64.16	50	φ16(H8)	φ52	13.5	27	29.42	20.52	13.5	-	-	-	48° 51'	φ40.8	441.2

カタログ記号の末尾に【H】を付した商品は歯部高周波焼入済です。【H】: Gear tooth surface completed with induction hardening, Hardness HRC 47 to 53.
【#】(シャープ)にはキー材とセットスクリューが付いております。【#】: Gear with key way and threaded hole / with key and screw.

許容伝達動力表 (kW) 曲げ強さ

Allowable transfer capability table (kW) Bending Strength

商品記号 Catalogue Numbers	回転速度 (min ⁻¹) revolution/min						
	10	100	200	400	600	800	1,000
M2.5S 20 - 4814	0.016	0.169	0.338	0.672	0.941	1.177	1.385
M2.5S 20 - 4814H	0.015	0.157	0.314	0.626	0.881	1.108	1.309
M2.5S 25 - 5016	0.027	0.279	0.558	1.069	1.480	1.829	2.171
M2.5S 25 - 5016H	0.026	0.261	0.522	1.005	1.398	1.737	2.051

The above references are JGMA standard.

動力の換算式は P26 をご参照ください。Please refer to the conversion formulas of power on page P26.

許容伝達動力表 (kW) 歯面強さ

Allowable transfer capability table (kW) Surface Durability

商品記号 Catalogue Numbers	回転速度 (min ⁻¹) revolution/min						
	10	100	200	400	600	800	1,000
M2.5S 20 - 4814	0.001	0.013	0.028	0.056	0.080	0.101	0.121
M2.5S 20 - 4814H	0.003	0.038	0.079	0.162	0.232	0.295	0.353
M2.5S 25 - 5016	0.002	0.027	0.055	0.107	0.150	0.189	0.229
M2.5S 25 - 5016H	0.006	0.075	0.154	0.307	0.435	0.547	0.653

JIS B1704 3級 (歯部高周波焼入品:4級)
System of Accuracy: JIS B 1704 Class 3
(Induction hardened products: Class 4)



御注文には必ず“フルネームで商品記号”を明記してください。
Please refer to the catalogue reference while ordering.
 d_s の寸法は参考値です。
Dimension of d_s is for reference only.

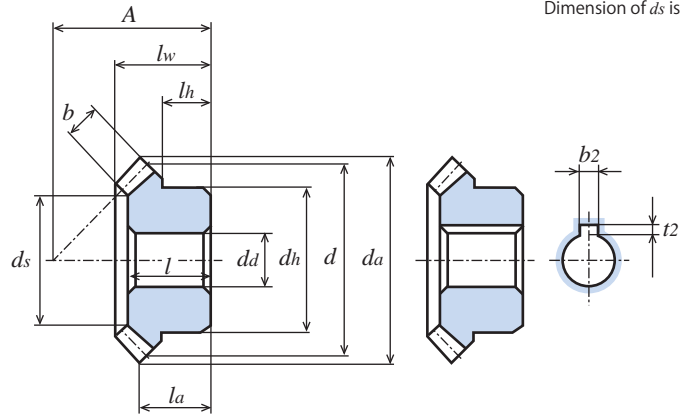

S45C 機械構造用炭素鋼 (JIS G 4051)

Material: Carbon Steel (ISO C45)

単位: mm
Dimensions: mm

商品記号 Catalogue Number	歯数比 Ratio	歯数 Number of Teeth	基準円直径 Reference Diameter	歯先円直径 Tip Diameter	組立距離 Locating Distance	穴径 Bore Diameter	ハブ外径 Hub Diameter	ハブ長さ Hub Projection	穴長さ Bore Length	全長 Overall Length	歯幅 Face Width	キー溝 Key Way	ねじ Set Screw		歯先角 Face Angle	重量 Weight		
													2-M	ls			δ_a	d_s
M2.5S 30 - 6318	1	30	$\phi 75$	$\phi 76.7$	63	$\phi 18$	$\phi 55$	20.5	34.5	37.71	27.27	15.5	-	-	47°42'	$\phi 49.1$	711.1	
M2.5S 30 - 6318H	1	30	$\phi 75$	$\phi 76.7$	63	$\phi 18(H8)$	$\phi 55$	20.5	34.5	37.71	27.27	15.5	-	-	47°42'	$\phi 49.1$	711.1	
M2.5S 30 # 6320H	1	30	$\phi 75$	$\phi 76.7$	63	$\phi 20(H8)$	$\phi 55$	20.5	34.5	37.71	27.27	15.5	6 × 2.8	2-M5	10.5	47°42'	$\phi 49.1$	688.1
M2.5S 30 # 6325H	1	30	$\phi 75$	$\phi 76.7$	63	$\phi 25(H8)$	$\phi 55$	20.5	34.5	37.71	27.27	15.5	8 × 3.3	2-M6	10.5	47°42'	$\phi 49.1$	637.2
M2.5S 30 - 5016	1	30	$\phi 75$	$\phi 76.7$	50	$\phi 16$	$\phi 55$	7.5	21.5	24.71	14.27	15.5	-	-	47°42'	$\phi 49.1$	503.6	
M2.5S 30 - 5016H	1	30	$\phi 75$	$\phi 76.7$	50	$\phi 16(H8)$	$\phi 55$	7.5	21.5	24.71	14.27	15.5	-	-	47°42'	$\phi 49.1$	503.6	
M2.5S 30 = 5020H	1	30	$\phi 75$	$\phi 76.7$	50	$\phi 20(H8)$	$\phi 55$	7.5	21.5	24.71	14.27	15.5	6 × 2.8	-	47°42'	$\phi 49.1$	481.7	
M2.5S 30 = 5025H	1	30	$\phi 75$	$\phi 76.7$	50	$\phi 25(H8)$	$\phi 55$	7.5	21.5	24.71	14.27	15.5	8 × 3.3	-	47°42'	$\phi 49.1$	450.9	

カタログ記号の末尾に【H】を付した商品は歯部高周波焼入済です。【H】: Gear tooth surface completed with induction hardening, Hardness HRC 47 to 53.
【#】(シャープ)にはキー材とセットスクリューが付いております。【#】: Gear with key way and threaded hole / with key and screw.

	歯数比 Ratio	ピッチ角 Pitch Angle	軸角 Shaft Angle
マイタギヤ Miter gear	1:1	45°	90°
ベベルギヤ Bevel gear	1:2	ピニオン ギヤ Pinion Gear	26° 34' 63° 26'
	1:3	ピニオン ギヤ Pinion Gear	18° 26' 71° 34'

許容伝達動力表 (kW) 曲げ強さ

Allowable transfer capability table (kW) Bending Strength

商品記号 Catalogue Numbers	回転速度 (min ⁻¹) revolution/min						
	10	100	200	400	600	800	1,000
M2.5S 30 - 6318	0.040	0.408	0.817	1.517	2.070	2.557	3.109
M2.5S 30 - 6318H	0.038	0.385	0.771	1.439	1.978	2.444	2.905

The above references are JGMA standard.

動力の換算式は P26 をご参照ください。Please refer to the conversion formulas of power on page P26.

許容伝達動力表 (kW) 歯面強さ

Allowable transfer capability table (kW) Surface Durability

商品記号 Catalogue Numbers	回転速度 (min ⁻¹) revolution/min						
	10	100	200	400	600	800	1,000
M2.5S 30 - 6318	0.004	0.046	0.094	0.177	0.247	0.312	0.387
M2.5S 30 - 6318H	0.011	0.128	0.264	0.509	0.712	0.891	1.069

マイタギヤ

MITER GEARS

モジュール **3**
MODULE

圧力角 20° 歯数比 1:1
1:1 Ratio 20° PRESSURE ANGLE

JIS B1704 3級 (歯部高周波焼入品:4級)
System of Accuracy: JIS B 1704 Class 3
(Induction hardened products: Class 4)



New 仕様変更 締結加工不要。
Additional machining on tightening is not necessary.

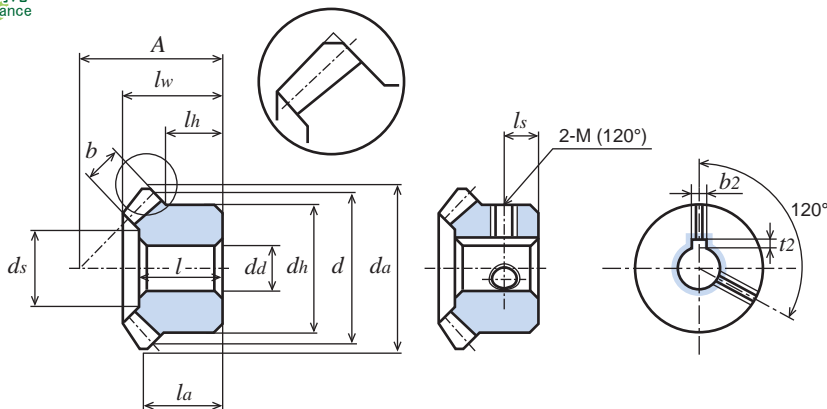

S45C 機械構造用炭素鋼 (JIS G 4051) Material: Carbon Steel (ISO C45)

単位: mm
Dimensions: mm

商品記号 Catalogue Number	歯数比 Ratio	歯数 Number of Teeth	基準円直径 Reference Diameter	歯先円直径 Tip Diameter	組立距離 Locating Distance	穴径 Bore Diameter	ハブ外径 Hub Diameter	ハブ長さ Hub Projection	穴長さ Bore Length	全長 Overall Length	Tip Distance	歯幅 Face Width	キミぞ Key Way	ねじ Set Screw		歯先角 Face Angle	重量 Weight	
														2-M	ls			δa
M3S 20 - 5816	1	20	φ60	(φ64.24) φ61.99	58	φ16	φ50	23	35	39.06	30.12	13.6	-	-	-	49° 3'	φ35.5	520.3
M3S 20 - 5816H	1	20	φ60	(φ64.24) φ61.99	58	φ16(H8)	φ50	23	35	39.06	30.12	13.6	-	-	-	49° 3'	φ35.5	520.3
M3S 20 # 5818H	1	20	φ60	(φ64.24) φ61.99	58	φ18(H8)	φ50	23	35	39.06	30.12	13.6	6 × 2.8	2-M6	11.5	49° 3'	φ35.5	498.1
M3S 20 # 5820H	1	20	φ60	(φ64.24) φ61.99	58	φ20(H8)	φ50	23	35	39.06	30.12	13.6	6 × 2.8	2-M6	11.5	49° 3'	φ35.5	481.9
M3S 20 # 5825H	1	20	φ60	(φ64.24) φ61.99	58	φ25(H8)	φ50	23	35	39.06	30.12	13.6	8 × 3.3	2-M6	11.5	49° 3'	φ35.5	431.2
M3S 20 - 4216	1	20	φ60	(φ64.24) φ61.99	42	φ16	φ50	7	19	23.06	14.12	13.6	-	-	-	49° 3'	φ35.5	298.9
M3S 20 - 4216H	1	20	φ60	(φ64.24) φ61.99	42	φ16(H8)	φ50	7	19	23.06	14.12	13.6	-	-	-	49° 3'	φ35.5	298.9
M3S 20 = 4218H	1	20	φ60	(φ64.24) φ61.99	42	φ18(H8)	φ50	7	19	23.06	14.12	13.6	6 × 2.8	-	-	49° 3'	φ35.5	288.4
M3S 20 = 4220H	1	20	φ60	(φ64.24) φ61.99	42	φ20(H8)	φ50	7	19	23.06	14.12	13.6	6 × 2.8	-	-	49° 3'	φ35.5	279.5
M3S 20 = 4225H	1	20	φ60	(φ64.24) φ61.99	42	φ25(H8)	φ50	7	19	23.06	14.12	13.6	8 × 3.3	-	-	49° 3'	φ35.5	251.7
M3S 25 - 6020	1	25	φ75	(φ79.24) φ77	60	φ20	φ65	17.5	32	35.31	24.62	16.2	-	-	-	48° 51'	φ48.1	785.6
M3S 25 - 6020H	1	25	φ75	(φ79.24) φ77	60	φ20(H8)	φ65	17.5	32	35.31	24.62	16.2	-	-	-	48° 51'	φ48.1	785.6

カタログ記号の末尾に【H】を付した商品は歯部高周波焼入済です。【H】: Gear tooth surface completed with induction hardening, Hardness HRC 47 to 53.
【#】(シャープ)にはキー材とセットスクリーが付いております。【#】: Gear with key way and threaded hole / with key and screw.

歯先円直径 da の () 内は理論値です。最大外径は軸心と平行に面取りしてありますので、理論値より小さくなっています。

The numeric indicated in the bracket () under the column. Outside diameter da has been machined flat. With this process, the outer diameter is smaller than the theory with respect to shaft center to parallel.

許容伝達動力表 (kW) 曲げ強さ

Allowable transfer capability table (kW) Bending Strength

商品記号 Catalogue Numbers	回転速度 (min ⁻¹) revolution/min						
	10	100	200	400	600	800	1,000
M3S 20 - 5816	0.029	0.297	0.594	1.148	1.591	1.971	2.323
M3S 20 - 5816H	0.027	0.275	0.551	1.068	1.489	1.854	2.184
M3S 25 - 6020	0.048	0.482	0.964	1.789	2.442	3.016	3.667
M3S 25 - 6020H	0.045	0.451	0.902	1.684	2.315	2.861	3.400

The above references are JGMA standard.

動力の換算式は P26 をご参照ください。Please refer to the conversion fomulas of power on page P26.

許容伝達動力表 (kW) 歯面強さ

Allowable transfer capability table (kW) Surface Durability

商品記号 Catalogue Numbers	回転速度 (min ⁻¹) revolution/min						
	10	100	200	400	600	800	1,000
M3S 20 - 5816	0.002	0.025	0.050	0.098	0.139	0.175	0.209
M3S 20 - 5816H	0.006	0.068	0.140	0.281	0.398	0.503	0.598
M3S 25 - 6020	0.004	0.048	0.097	0.184	0.256	0.323	0.401
M3S 25 - 6020H	0.011	0.131	0.272	0.523	0.732	0.916	1.100

JIS B1704 3級 (歯部高周波焼入品:4級)
System of Accuracy: JIS B 1704 Class 3
(Induction hardened products: Class 4)



御注文には必ず“フルネームで商品記号”を明記してください。
Please refer to the catalogue reference while ordering.
 d_s の寸法は参考値です。
Dimension of d_s is for reference only.

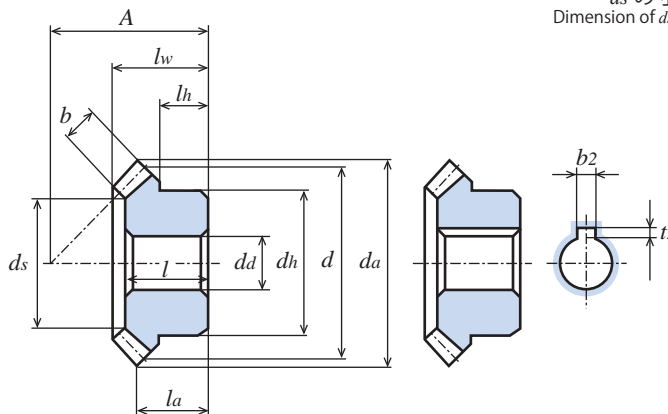

S45C 機械構造用炭素鋼 (JIS G 4051)

Material: Carbon Steel (ISO C45)

単位: mm
Dimensions: mm

商品記号 Catalogue Number	歯数比 Ratio	歯数 Number of Teeth	基準円直径 Reference Diameter	歯先円直径 Tip Diameter	組立距離 Locating Distance	穴径 Bore Diameter	ハブ外径 Hub Diameter	ハブ長さ Hub Projection	穴長さ Bore Length	全長 Overall Length	Tip Distance	歯幅 Face Width	キミぞ Key Way	ねじ Set Screw		歯先角 Face Angle	歯先角 Face Angle	重量 Weight
														2-M	ls			
M3S 30 - 7522	1	30	$\phi 90$	$\phi 92.04$	75	$\phi 22$	$\phi 66$	23.64	40	44.65	32.12	18.6	-	-	-	47°42'	$\phi 57.3$	1.20
M3S 30 - 7522H	1	30	$\phi 90$	$\phi 92.04$	75	$\phi 22$ (H8)	$\phi 66$	23.64	40	44.65	32.12	18.6	-	-	-	47°42'	$\phi 57.3$	1.20
M3S 30 # 7525H	1	30	$\phi 90$	$\phi 92.04$	75	$\phi 25$ (H8)	$\phi 66$	23.64	40	44.65	32.12	18.6	8 × 3.3	2-M6	12	47°42'	$\phi 57.3$	1.16
M3S 30 # 7530H	1	30	$\phi 90$	$\phi 92.04$	75	$\phi 30$ (H8)	$\phi 66$	23.64	40	44.65	32.12	18.6	8 × 3.3	2-M6	12	47°42'	$\phi 57.3$	1.09
M3S 30 - 6020	1	30	$\phi 90$	$\phi 92.04$	60	$\phi 20$	$\phi 66$	8.64	25	29.65	17.12	18.6	-	-	-	47°42'	$\phi 57.3$	0.85
M3S 30 - 6020H	1	30	$\phi 90$	$\phi 92.04$	60	$\phi 20$ (H8)	$\phi 66$	8.64	25	29.65	17.12	18.6	-	-	-	47°42'	$\phi 57.3$	0.85
M3S 30 = 6025H	1	30	$\phi 90$	$\phi 92.04$	60	$\phi 25$ (H8)	$\phi 66$	8.64	25	29.65	17.12	18.6	8 × 3.3	-	-	47°42'	$\phi 57.3$	0.81
M3S 30 = 6030H	1	30	$\phi 90$	$\phi 92.04$	60	$\phi 30$ (H8)	$\phi 66$	8.64	25	29.65	17.12	18.6	8 × 3.3	-	-	47°42'	$\phi 57.3$	0.74

カタログ記号の末尾に【H】を付した商品は歯部高周波焼入済です。【H】: Gear tooth surface completed with induction hardening, Hardness HRC 47 to 53.
【#】(シャープ)にはキー材とセットスクリューが付いております。【#】: Gear with key way and threaded hole / with key and screw.

	歯数比 Ratio	ピッチ角 Pitch Angle	軸角 Shaft Angle
マイタギヤ Miter gear	1:1	45°	90°
ベベルギヤ Bevel gear	1:2	ピニオン ギヤ Pinion Gear	26° 34' 63° 26'
	1:3	ピニオン ギヤ Pinion Gear	18° 26' 71° 34'

許容伝達動力表 (kW) 曲げ強さ

Allowable transfer capability table (kW) Bending Strength

商品記号 Catalogue Numbers	回転速度 (min ⁻¹) revolution/min						
	10	100	200	400	600	800	1,000
M3S 30 - 7522	0.070	0.706	1.413	2.522	3.394	4.322	5.232
M3S 30 - 7522H	0.066	0.666	1.332	2.399	3.254	4.056	4.784

The above references are JGMA standard.

動力の換算式は P26 をご参照ください。Please refer to the conversion formulas of power on page P26.

許容伝達動力表 (kW) 歯面強さ

Allowable transfer capability table (kW) Surface Durability

商品記号 Catalogue Numbers	回転速度 (min ⁻¹) revolution/min						
	10	100	200	400	600	800	1,000
M3S 30 - 7522	0.008	0.082	0.166	0.303	0.418	0.547	0.678
M3S 30 - 7522H	0.020	0.225	0.464	0.862	1.190	1.502	1.790

マイタギヤ

MITER GEARS

モジュール 4

MODULE 4

圧力角 20° 歯数比 1:1
1:1 Ratio 20° PRESSURE ANGLE

JIS B1704 3級 (歯部高周波焼入品:4級)
System of Accuracy: JIS B 1704 Class 3
(Induction hardened products: Class 4)



New 仕様変更 締結加工不要。
Additional machining on tightening is not necessary.

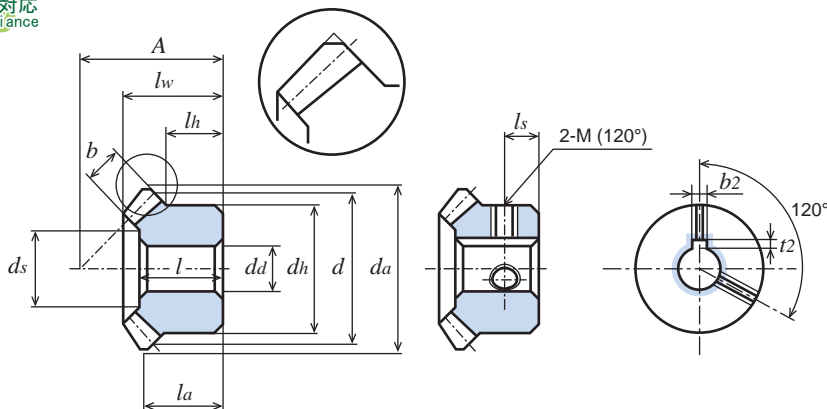

S45C 機械構造用炭素鋼 (JIS G 4051)

Material: Carbon Steel (ISO C45)

単位: mm
Dimensions: mm

商品記号 Catalogue Number	歯数比 Ratio	歯数 Number of Teeth	基準円直径 Reference Diameter	歯先円直径 Tip Diameter	組立距離 Locating Distance	穴径 Bore Diameter	ハブ外径 Hub Diameter	ハブ長さ Hub Projection	穴長さ Bore Length	全長 Overall Length	Tip Distance	歯幅 Face Width	キミぞ Key Way	ねじ Set Screw		歯先角 Face Angle	重量 Weight	
														2-M	ls			δa
M4S 20-7520	1	20	φ80	φ82.65 (φ85.66)	75	φ20	φ64	27	45	50.05	37.83	18.6	-	-	-	49° 3'	φ47.3	1.14
M4S 20-7520H	1	20	φ80	φ82.65 (φ85.66)	75	φ20(H8)	φ64	27	45	50.05	37.83	18.6	-	-	-	49° 3'	φ47.3	1.14
M4S 20 # 7525H	1	20	φ80	φ82.65 (φ85.66)	75	φ25(H8)	φ64	27	45	50.05	37.83	18.6	8 × 3.3	2-M8	13.5	49° 3'	φ47.3	1.06
M4S 20 # 7530H	1	20	φ80	φ82.65 (φ85.66)	75	φ30(H8)	φ64	27	45	50.05	37.83	18.6	8 × 3.3	2-M8	13.5	49° 3'	φ47.3	0.98

カタログ記号の末尾に【H】を付した商品は歯部高周波焼入済です。【H】: Gear tooth surface completed with induction hardening, Hardness HRC 47 to 53.
【#】(シャープ)にはキー材とセットスクリーが付いております。【#】: Gear with key way and threaded hole / with key and screw.

許容伝達動力表 (kW) 曲げ強さ

Allowable transfer capability table (kW) Bending Strength

商品記号 Catalogue Numbers	回転速度 (min ⁻¹) revolution/min						
	10	100	200	400	600	800	1,000
M4S 20-7520	0.071	0.719	1.438	2.634	3.577	4.465	5.421
M4S 20-7520H	0.066	0.663	1.327	2.448	3.349	4.150	4.920

許容伝達動力表 (kW) 歯面強さ

Allowable transfer capability table (kW) Surface Durability

商品記号 Catalogue Numbers	回転速度 (min ⁻¹) revolution/min						
	10	100	200	400	600	800	1,000
M4S 20-7520	0.006	0.062	0.126	0.236	0.327	0.418	0.516
M4S 20-7520H	0.015	0.168	0.347	0.660	0.920	1.154	1.382

The above references are JGMA standard.

動力の換算式は P26 をご参照ください。Please refer to the conversion formulas of power on page P26.

JIS B1704 3級 (歯部高周波焼入品:4級)
System of Accuracy: JIS B 1704 Class 3
(Induction hardened products: Class 4)



御注文には必ず“フルネームで商品記号”を明記してください。
Please refer to the catalogue reference while ordering.
 d_s の寸法は参考値です。
Dimension of d_s is for reference only.

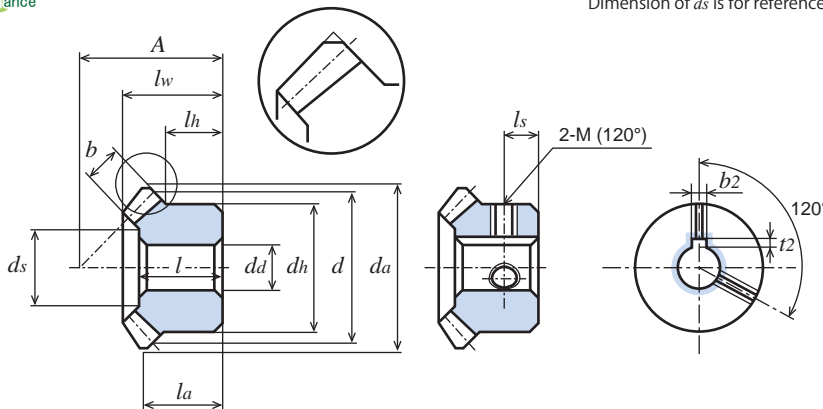

S45C 機械構造用炭素鋼 (JIS G 4051)

Material: Carbon Steel (ISO C45)

単位: mm
Dimensions: mm

商品記号 Catalogue Number	歯数比 Ratio u	歯数 Number of Teeth z	基準円直径 Reference Diameter d	歯先円直径 Tip Diameter d_a	組立距離 Locating Distance A	穴径 Bore Diameter $d_a(H7)$	ハブ外径 Hub Diameter d_h	ハブ長さ Hub Projection l_h	穴長さ Bore Length l	全長 Overall Length l_w	全長 Overall Length l_a	歯幅 Face Width b	キミぞ Key Way $b_2 \times t_2$	ねじ Set Screw		歯先角 Face Angle δ_a	歯先角 Face Angle d_s	重量 Weight $W(kg)$
														2-M	l_s			
M5S 20 - 9025	1	20	$\phi 100$	$\phi 103.3$ <small>($\phi 107.07$)</small>	90	$\phi 25$	$\phi 80$	30	53	59.04	43.54	23.6	-	-	-	49° 3'	$\phi 59.2$	2.11
M5S 20 - 9025H	1	20	$\phi 100$	$\phi 103.3$ <small>($\phi 107.07$)</small>	90	$\phi 25(H8)$	$\phi 80$	30	53	59.04	43.54	23.6	-	-	-	49° 3'	$\phi 59.2$	2.11
M5S 20 # 9030H	1	20	$\phi 100$	$\phi 103.3$ <small>($\phi 107.07$)</small>	90	$\phi 30(H8)$	$\phi 80$	30	53	59.04	43.54	23.6	8 × 3.3	2-M10	15	49° 3'	$\phi 59.2$	2.00
M5S 20 # 9040H	1	20	$\phi 100$	$\phi 103.3$ <small>($\phi 107.07$)</small>	90	$\phi 40(H8)$	$\phi 80$	30	53	59.04	43.54	23.6	12 × 3.3	2-M10	15	49° 3'	$\phi 59.2$	1.76

カタログ記号の末尾に【H】を付した商品は歯部高周波焼入済です。【H】: Gear tooth surface completed with induction hardening, Hardness HRC 47 to 53.
【#】(シャープ)にはキー材とセットスクリーンが付いております。【#】: Gear with key way and threaded hole / with key and screw.

許容伝達動力表 (kW) 曲げ強さ

Allowable transfer capability table (kW) Bending Strength

商品記号 Catalogue Numbers	回転速度 (min ⁻¹) revolution/min						
	10	100	200	400	600	800	1,000
M5S 20 - 9025	0.142	1.421	2.825	4.949	6.669	8.574	10.318
M5S 20 - 9025H	0.130	1.308	2.601	4.603	6.220	7.758	-

The above references are JGMA standard.

動力の換算式は P26 をご参照ください。Please refer to the conversion formulas of power on page P26.

許容伝達動力表 (kW) 歯面強さ

Allowable transfer capability table (kW) Surface Durability

商品記号 Catalogue Numbers	回転速度 (min ⁻¹) revolution/min						
	10	100	200	400	600	800	1,000
M5S 20 - 9025	0.012	0.127	0.255	0.458	0.635	0.836	1.040
M5S 20 - 9025H	0.030	0.338	0.694	1.267	1.743	2.201	-