

歯研平歯車

GROUND SPUR GEARS

モジュール **0.5** 圧力角 20° (並歯)
 MODULE 20° PRESSURE ANGLE FULL DEPTH TOOTH

歯部高周波焼き入れ HRC49 ~ 55
 JIS B 1702-1 (ISO) 5 級
 System of accuracy: JIS B1702-1(ISO) class 5



New **ねじを2箇所 (120°配) にしました。**
締結力が1.6倍になりました。
 New item with two threaded holes (120°)
 Tightening power increased by 1.6 times.

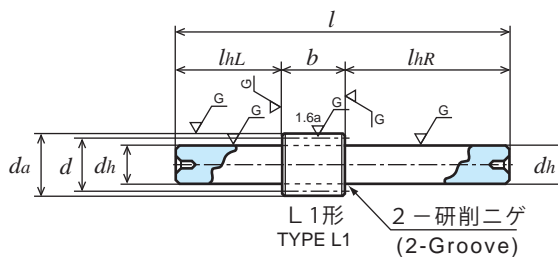

SCM435、440 クロムモリブデン鋼 (JIS G 4053)

Material : Chromium Molybdenum Steel (ISO 34CrMo4, 42CrMo4)

単位 : mm
 Dimensions : mm

商品記号 Catalogue Number	歯数 Number of Teeth z	基準円直径 Reference Diameter d	歯先円直径 Tip Diameter da	形 Type	歯幅 Face Width b	穴径 Bore Diameter da(H7)	ハブ外径 Hub Diameter dh	ハブ長さ Hub Projection lh	全長 Overall Length l	ねじ Set Screw		キリ Tap Guide dr	重量 Weight W(g)
										M	ls		
SG50S 20L - 0806	20	φ10	φ11	L1	8	-	φ 6 (h7)	L22 R50	80	-	-	-	20.8
SG50S 22L - 0808	22	φ11	φ12	L1	8	-	φ 8 (h7)	L22 R50	80	-	-	-	34.2
SG50S 24L - 0810	24	φ12	φ13	L1	8	-	φ10 (h7)	L22 R50	80	-	-	-	51.1
SG50S 25L - 0810	25	φ12.5	φ13.5	L1	8	-	φ10 (h7)	L22 R50	80	-	-	-	51.7
SG50S 26L - 0810	26	φ13	φ14	L1	8	-	φ10 (h7)	L22 R50	80	-	-	-	52.4
SG50S 28B - 0805	28	φ14	φ15	B1	8	φ5	φ10	8	16	-	-	-	12.1
SG50S 30B - 0805	30	φ15	φ16	B1	8	φ5	φ12	8	16	-	-	-	15.6
SG50S 30B - 0806	30	φ15	φ16	B1	8	φ6	φ12	8	16	-	-	-	14.5
SG50S 30B * 0806	30	φ15	φ16	B1	8	φ6	φ12	8	16	2-M3	4	-	14.4
SG50S 32B - 0805	32	φ16	φ17	B1	8	φ5	φ12	8	16	-	-	-	17.2
SG50S 32B - 0806	32	φ16	φ17	B1	8	φ6	φ12	8	16	-	-	-	16.1

セットスクリューはついておりません。 [*] : Gear with Two Thread holes / without Set Screw.
 Gear tooth surface completed with induction hardening, Hardness HRC49 to 55.

許容伝達動力表 曲げ強さ (W)

Allowable transfer capability table (W) Bending Strength

歯数 z	歯幅 b	回転速度 (min ⁻¹) revolution/min						
		400	800	1,200	1,500	1,800	2,500	3,000
20	8	108.04	216.08	324.12	405.15	486.18	675.25	810.30
22	8	124.31	248.63	372.94	466.17	559.41	776.95	932.34
24	8	140.85	281.70	422.54	528.18	633.81	880.30	1,056.36
25	8	149.23	298.46	447.69	559.61	671.53	932.68	1,119.22
26	8	157.67	315.34	473.01	591.26	709.51	985.43	1,182.52
28	8	174.71	349.41	524.12	655.15	786.18	1,091.91	1,310.30
30	8	191.83	383.66	575.50	719.37	863.24	1,198.95	1,438.74
32	8	209.19	418.38	627.57	784.46	941.35	1,307.43	1,568.92

歯面強さ (W)

Allowable transfer capability table (W) Surface Durability

回転速度 (min ⁻¹) revolution/min						
400	800	1,200	1,500	1,800	2,500	3,000
25.17	50.59	76.25	95.65	115.17	161.15	194.36
30.61	61.55	92.81	116.45	140.25	196.36	236.91
36.59	73.62	111.05	139.38	167.91	235.22	283.88
39.79	80.07	120.81	151.65	182.72	256.03	309.05
43.13	86.81	131.00	164.46	198.18	277.76	335.34
50.22	101.12	152.66	191.71	231.06	324.02	391.30
57.86	116.57	176.05	221.13	266.60	374.03	451.82
66.06	133.15	201.17	252.76	304.79	427.81	516.93

The above numerical values are equivalent to JGMA formulas as reference only.
 動力の換算式は P26 をご参照ください。 Please refer to the conversion fomulas of power on page P26.

歯研平歯車 GROUND SPUR GEARS

モジュール **0.5** 圧力角 20° (並歯)
MODULE 20° PRESSURE ANGLE FULL DEPTH TOOTH

歯部高周波焼き入れ HRC49 ~ 55
JIS B 1702-1 (ISO) 5 級
System of accuracy: JIS B1702-1(ISO) class 5



御注文には必ず “フルネームで商品記号” を明記してください。
Please refer to the catalogue reference while ordering.

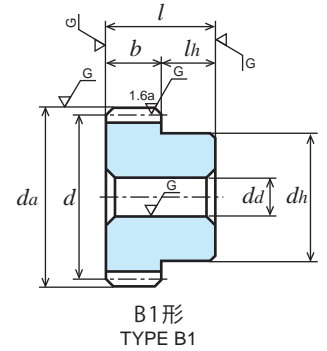
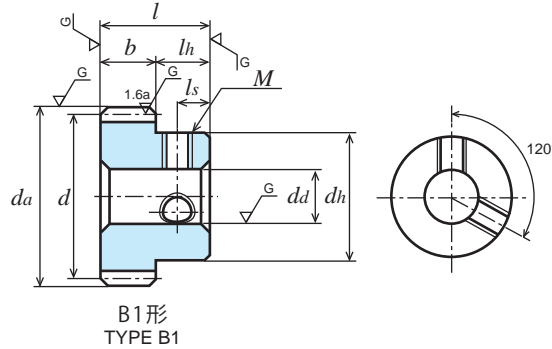

SCM435、440 クロムモリブデン鋼 (JIS G 4053) Material : Chromium Molybdenum Steel (ISO 34CrMo4, 42CrMo4)

単位 : mm
Dimensions : mm

商品記号 Catalogue Number	歯数 Number of Teeth <i>z</i>	基準円直径 Reference Diameter <i>d</i>	歯先円直径 Tip Diameter <i>da</i>	形 Type	歯幅 Face Width <i>b</i>	穴径 Bore Diameter <i>da</i> (H7)	ハブ外径 Hub Diameter <i>dh</i>	ハブ長さ Hub Projection <i>lh</i>	全長 Overall Length <i>l</i>	ねじ Set Screw		キリ Tap Guide <i>dr</i>	重量 Weight <i>W</i> (g)
										<i>M</i>	<i>ls</i>		
SG50S 35B - 0805	35	φ17.5	φ18.5	B1	8	φ5	φ14	8	16	-	-	-	22.2
SG50S 36B - 0806	36	φ18	φ19	B1	8	φ6	φ16	8	16	-	-	-	24.9
SG50S 36B - 0808	36	φ18	φ19	B1	8	φ8	φ16	8	16	-	-	-	22.1
SG50S 40B - 0806	40	φ20	φ21	B1	8	φ6	φ16	8	16	-	-	-	28.6
SG50S 40B - 0808	40	φ20	φ21	B1	8	φ8	φ16	8	16	-	-	-	25.9
SG50S 40B * 0808	40	φ20	φ21	B1	8	φ8	φ16	8	16	2-M4	4	-	25.5
SG50S 45B - 0808	45	φ22.5	φ23.5	B1	8	φ8	φ16	8	16	-	-	-	31.1
SG50S 48B - 0808	48	φ24	φ25	B1	8	φ8	φ20	8	16	-	-	-	34.5

セットスクリューはついておりません。 [*] : Gear with Two Thread holes / without Set Screw.
Gear tooth surface completed with induction hardening, Hardness HRC49 to 55.

許容伝達動力表 曲げ強さ (W)

Allowable transfer capability table (W) Bending Strength

歯数 <i>z</i>	歯幅 <i>b</i>	回転速度 (min ⁻¹) revolution/min						
		400	800	1,200	1,500	1,800	2,500	3,000
35	8	235.49	470.97	706.46	883.07	1,059.69	1,471.79	1,766.14
36	8	244.32	488.63	732.95	916.18	1,099.42	1,526.97	1,832.36
40	8	279.89	559.78	839.67	1,049.58	1,259.50	1,749.30	2,091.76
42	8	297.82	595.64	893.46	1,116.83	1,340.19	1,861.38	2,217.10
44	8	315.62	631.24	946.87	1,183.58	1,420.30	1,972.64	2,340.50
45	8	324.64	649.28	973.91	1,217.39	1,460.87	2,028.99	2,402.69
48	8	351.79	703.58	1,055.38	1,319.22	1,583.07	2,190.95	2,588.62

The above numerical values are equivalent to JGMA formulas as reference only.

動力の換算式は P26 をご参照ください。 Please refer to the conversion fomulas of power on page P26.

歯面強さ (W)

Allowable transfer capability table (W) Surface Durability

回転速度 (min ⁻¹) revolution/min							
400	800	1,200	1,500	1,800	2,500	3,000	
79.42	160.18	242.14	304.34	367.11	515.63	623.27	
84.16	169.76	256.68	322.65	389.24	546.82	661.05	
104.51	211.00	319.25	401.49	484.56	681.25	821.03	
115.54	233.37	353.22	444.30	536.33	754.32	905.72	
127.15	256.91	388.98	489.39	590.86	831.31	994.49	
133.17	269.12	407.53	512.79	619.17	871.29	1,040.39	
152.08	307.52	465.92	586.43	708.29	993.65	1,184.13	

目次
CONTENTS

インフォメーション
INFORMATION

ギヤボックス
GEAR BOXES

ノーバックラッシュギヤ
ANTI BACKLASH SPUR GEARS

歯研平歯車
GROUND SPUR GEARS

平歯車
SPUR GEARS

内歯車
INTERNAL GEARS

歯ラック
GROUND RACKS

ラック
RACKS

へリカル・スプリングギヤ
HELICAL GEARS AND SCREW GEARS

ウォーム・ウォームギヤ
WORMS AND WORM GEARS

かさ歯車
BEVEL GEARS

スプロケット
SPROCKETS

技術資料
REFERENCE DATA

歯研平歯車 GROUND SPUR GEARS

モジュール **0.5** 圧力角 20° (並歯)
MODULE 20° PRESSURE ANGLE FULL DEPTH TOOTH

歯部高周波焼き入れ Hrc49 ~ 55
JIS B 1702-1 (ISO) 5 級
System of accuracy: JIS B1702-1(ISO) class 5



New **ねじを2箇所 (120° 配) にしました。**
締結力が 1.6 倍になりました。
New item with two threaded holes (120°)
Tightening power increased by 1.6 times.

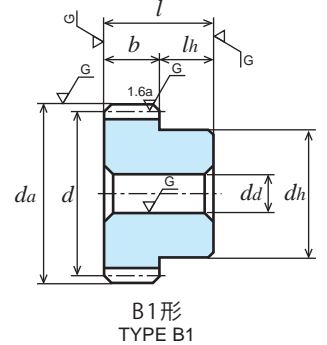
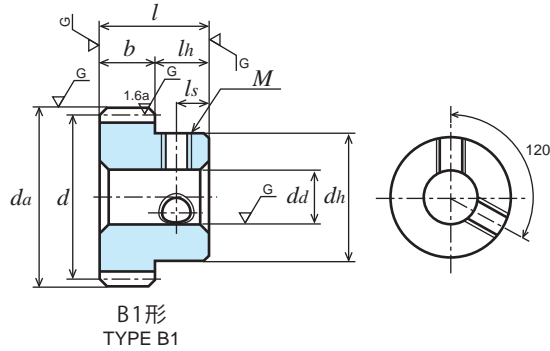

SCM435、440 クロムモリブデン鋼 (JIS G 4053) Material : Chromium Molybdenum Steel (ISO 34CrMo4, 42CrMo4)

単位 : mm
Dimensions : mm

商品記号 Catalogue Number	歯数 Number of Teeth z	基準円直径 Reference Diameter d	歯先円直径 Tip Diameter da	形 Type	歯幅 Face Width b	穴径 Bore Diameter da(H7)	ハブ外径 Hub Diameter dh	ハブ長さ Hub Projection lh	全長 Overall Length l	ねじ Set Screw		キリ Tap Guide dr	重量 Weight W(g)
										M	ls		
SG50S 50B - 0808	50	φ25	φ26	B1	8	φ 8	φ20	8	16	-	-	-	43.9
SG50S 50B - 0810	50	φ25	φ26	B1	8	φ10	φ20	8	16	-	-	-	40.4
SG50S 50B * 0810	50	φ25	φ26	B1	8	φ10	φ20	8	16	2-M4	4	-	40.0
SG50S 54B - 0808	54	φ27	φ28	B1	8	φ 8	φ20	8	16	-	-	-	49.0
SG50S 55B - 0808	55	φ27.5	φ28.5	B1	8	φ 8	φ20	8	16	-	-	-	50.4
SG50S 56B - 0808	56	φ28	φ29	B1	8	φ 8	φ20	8	16	-	-	-	51.7
SG50S 60B - 0808	60	φ30	φ31	B1	8	φ 8	φ22	8	16	-	-	-	61.5
SG50S 60B - 0810	60	φ30	φ31	B1	8	φ10	φ22	8	16	-	-	-	58.0
SG50S 60B * 0810	60	φ30	φ31	B1	8	φ10	φ22	8	16	2-M4	4	-	57.6
SG50S 64B - 0808	64	φ32	φ33	B1	8	φ 8	φ22	8	16	-	-	-	67.6
SG50S 70B - 0808	70	φ35	φ36	B1	8	φ 8	φ22	8	16	-	-	-	77.4

セットスクリューはついておりません。 [*] : Gear with Two Thread holes / without Set Screw.
Gear tooth surface completed with induction hardening, Hardness HRC49 to 55.

許容伝達動力表 曲げ強さ (W)

Allowable transfer capability table (W) Bending Strength

歯数 z	歯幅 b	回転速度 (min ⁻¹) revolution/min						
		400	800	1,200	1,500	1,800	2,500	3,000
50	8	369.97	739.94	1,109.91	1,387.38	1,664.86	2,296.66	2,711.92
52	8	388.21	776.41	1,164.62	1,455.78	1,746.93	2,402.07	2,834.73
54	8	406.49	812.98	1,219.47	1,524.34	1,829.21	2,507.08	2,956.93
55	8	415.65	831.31	1,246.96	1,558.70	1,870.44	2,559.46	3,017.83
56	8	424.83	849.65	1,274.47	1,593.09	1,911.71	2,611.72	3,078.57
60	8	461.62	923.25	1,384.87	1,731.08	2,077.30	2,819.79	3,320.04
64	8	498.57	997.13	1,495.70	1,869.62	2,242.66	3,023.11	3,559.67
70	8	554.23	1,108.46	1,662.69	2,078.37	2,475.56	3,332.20	3,927.74

歯面強さ (W)

Allowable transfer capability table (W) Surface Durability

回転速度 (min ⁻¹) revolution/min						
400	800	1,200	1,500	1,800	2,500	3,000
165.41	334.61	507.12	638.42	771.20	1,078.73	1,284.96
179.32	362.89	550.15	692.72	836.93	1,167.23	1,389.78
193.81	392.37	595.01	749.36	905.50	1,259.13	1,498.55
201.28	407.56	618.14	778.55	940.85	1,306.36	1,554.41
208.89	423.05	641.73	808.33	976.92	1,354.43	1,611.25
240.80	488.02	740.72	933.35	1,128.33	1,555.13	1,848.36
275.06	557.86	847.18	1,067.84	1,290.76	1,769.21	2,101.33
330.89	671.79	1,020.99	1,287.52	1,545.96	2,115.13	2,518.03

The above numerical values are equivalent to JGMA formulas as reference only.

動力の換算式は P26 をご参照ください。Please refer to the conversion fomulas of power on page P26.

歯研平歯車

GROUND SPUR GEARS

モジュール **0.5** 圧力角 20° (並歯)
 MODULE 20° PRESSURE ANGLE FULL DEPTH TOOTH

歯部高周波焼き入れ HRC49 ~ 55
 JIS B 1702-1 (ISO) 5 級
 System of accuracy: JIS B1702-1(ISO) class 5



御注文には必ず “フルネームで商品記号” を明記してください。
 Please refer to the catalogue reference while ordering.

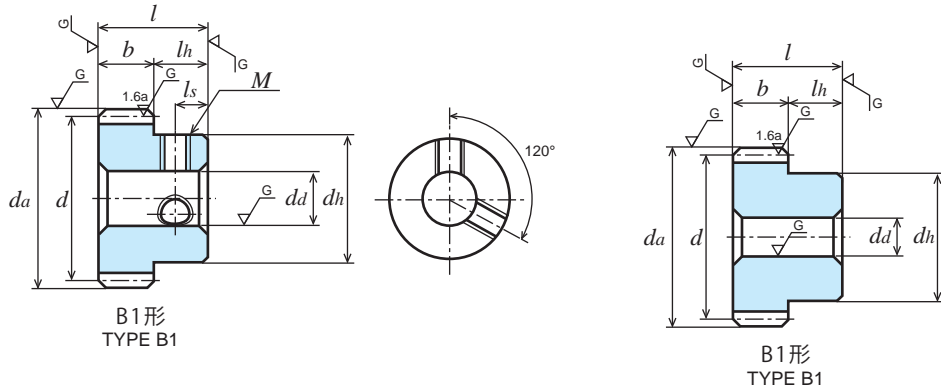

SCM435、440 クロムモリブデン鋼 (JIS G 4053)

Material : Chromium Molybdenum Steel (ISO 34CrMo4, 42CrMo4)

単位 : mm
 Dimensions : mm

商品記号 Catalogue Number	歯数 Number of Teeth z	基準円直径 Reference Diameter d	歯先円直径 Tip Diameter da	形 Type	歯幅 Face Width b	穴径 Bore Diameter da(H7)	ハブ外径 Hub Diameter dh	ハブ長さ Hub Projection lh	全長 Overall Length l	ねじ Set Screw		キリ Tap Guide dr	重量 Weight W(g)
										M	ls		
SG50S 72B - 0808	72	φ36	φ37	B1	8	φ 8	φ25	8	16	-	-	-	87.8
SG50S 75B - 0808	75	φ37.5	φ38.5	B1	8	φ 8	φ25	8	16	-	-	-	93.2
SG50S 80B - 0808	80	φ40	φ41	B1	8	φ 8	φ25	8	16	-	-	-	102.7
SG50S 80B - 0810	80	φ40	φ41	B1	8	φ10	φ25	8	16	-	-	-	99.2
SG50S 80B - 0812	80	φ40	φ41	B1	8	φ12	φ25	8	16	-	-	-	94.9
SG50S 80B * 0812	80	φ40	φ41	B1	8	φ12	φ25	8	16	2-M5	4	-	94.1
SG50S 90B - 0810	90	φ45	φ46	B1	8	φ10	φ30	8	16	-	-	-	133.5
SG50S 96B - 0810	96	φ48	φ49	B1	8	φ10	φ30	8	16	-	-	-	147.1
SG50S 100B - 0810	100	φ50	φ51	B1	8	φ10	φ30	8	16	-	-	-	156.7
SG50S 100B - 0812	100	φ50	φ51	B1	8	φ12	φ30	8	16	-	-	-	152.4
SG50S 100B * 0812	100	φ50	φ51	B1	8	φ12	φ30	8	16	2-M5	4	-	151.5
SG50S 108B - 0810	108	φ54	φ55	B1	8	φ10	φ35	8	16	-	-	-	193.0
SG50S 112B - 0810	112	φ56	φ57	B1	8	φ10	φ35	8	16	-	-	-	203.8
SG50S 120B - 0810	120	φ60	φ61	B1	8	φ10	φ35	8	16	-	-	-	226.6

セットスクリューはついておりません。 [*]: Gear with Two Thread holes / without Set Screw.
 Gear tooth surface completed with induction hardening, Hardness HRC49 to 55.

許容伝達動力表 曲げ強さ (W)

Allowable transfer capability table (W) Bending Strength

歯数 z	歯幅 b	回転速度 (min ⁻¹) revolution/min						
		400	800	1,200	1,500	1,800	2,500	3,000
72	8	572.84	1,145.69	1,178.53	2,148.17	2,552.72	3,433.30	4,049.63
75	8	600.84	1,201.61	1,802.41	2,253.02	2,667.98	3,584.01	4,231.63
80	8	647.54	1,295.08	1,942.62	2,419.70	2,858.90	3,839.99	4,532.93
90	8	740.43	1,480.87	2,221.30	2,740.03	3,231.68	4,345.90	5,120.65
96	8	796.77	1,593.54	2,389.35	2,931.46	3,453.87	4,647.97	5,470.63
100	8	834.38	1,668.76	2,494.32	3,058.06	3,600.58	4,847.65	5,701.55
108	8	909.75	1,819.50	2,702.70	3,308.89	3,893.39	5,243.00	6,135.59
112	8	947.51	1,895.02	2,806.16	3,433.16	4,042.91	5,438.74	6,345.45
120	8	1,023.12	2,046.24	3,011.40	3,679.20	4,339.67	5,826.04	6,757.02

The above numerical values are equivalent to JGMA formulas as reference only.

動力の換算式は P26 をご参照ください。Please refer to the conversion fomulas of power on page P26.

歯面強さ (W)

Allowable transfer capability table (W) Surface Durability

回転速度 (min ⁻¹) revolution/min						
400	800	1,200	1,500	1,800	2,500	3,000
350.69	712.23	1,082.72	1,365.57	1,636.03	2,236.98	2,665.11
381.51	775.21	1,178.89	1,487.18	1,775.81	2,425.83	2,893.33
435.87	886.40	1,348.78	1,696.04	2,021.16	2,761.77	3,293.88
555.93	1,132.30	1,724.83	2,149.18	2,557.83	3,501.66	4,169.72
635.27	1,295.04	1,973.12	2,446.11	2,908.90	3,986.43	4,742.36
691.23	1,409.92	2,142.24	2,654.41	3,154.91	4,326.43	5,143.47
810.54	1,655.11	2,500.92	3,095.63	3,677.90	5,046.42	5,969.89
873.91	1,785.46	2,690.44	3,328.44	3,958.21	5,426.21	6,400.03
1,008.14	2,061.81	3,089.65	3,818.25	4,549.00	6,224.91	7,298.89

目次 CONTENTS
 インフォメーション INFORMATION
 ギヤボックス GEAR BOXES
 ノーバックラッシュギヤ ANTI BACKLASH SPUR GEARS
 歯研平歯車 GROUND SPUR GEARS
 平歯車 SPUR GEARS
 内歯車 INTERNAL GEARS
 歯研ラック GROUND RACKS
 ラック RACKS
 へリカル・スクリューギヤ HELICAL GEARS AND SCREW GEARS
 マーモット・マニマニギヤ WORMS AND WORM WHEELS
 かみ歯車 BEVEL GEARS
 スプロケット SPROCKETS
 技術資料 REFERENCE DATA

歯研平歯車

GROUND SPUR GEARS

モジュール **0.8** 圧力角 20° (並歯)
 MODULE 20° PRESSURE ANGLE FULL DEPTH TOOTH

歯部高周波焼き入れ Hrc49 ~ 55
 JIS B 1702-1 (ISO) 5 級
 System of accuracy: JIS B1702-1(ISO) class 5



New **ねじを2箇所 (120°配) にしました。**
締結力が1.6倍になりました。
 New item with two threaded holes (120°)
 Tightening power increased by 1.6 times.

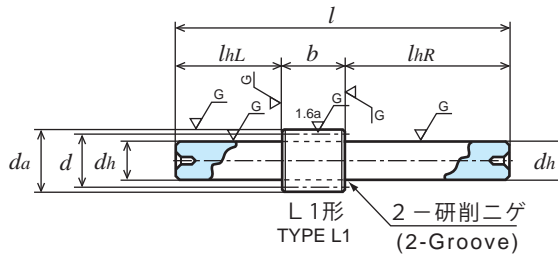

SCM435、440 クロムモリブデン鋼 (JIS G 4053)

Material : Chromium Molybdenum Steel (ISO 34CrMo4, 42CrMo4)

単位 : mm
 Dimensions : mm

商品記号 Catalogue Number	歯数 Number of Teeth z	基準円直径 Reference Diameter d	歯先円直径 Tip Diameter da	形 Type	歯幅 Face Width b	穴径 Bore Diameter da(H7)	ハブ外径 Hub Diameter dh	ハブ長さ Hub Projection lh	全長 Overall Length l	ねじ Set Screw		キリ Tap Guide dr	重量 Weight W(g)
										M	ls		
SG80S 15L - 0806	15	φ12	φ13.6	L1	8	-	φ 6 (h7)	L22 R60	90	-	-	-	25.1
SG80S 16L - 0806	16	φ12.8	φ14.4	L1	8	-	φ 6 (h7)	L22 R60	90	-	-	-	26.1
SG80S 18L - 0808	18	φ14.4	φ16	L1	8	-	φ 8 (h7)	L22 R60	90	-	-	-	42.3
SG80S 20L - 0810	20	φ16	φ17.6	L1	8	-	φ10 (h7)	L22 R60	90	-	-	-	62.7
SG80S 22B - 0806	22	φ17.6	φ19.2	B1	8	φ 6	φ14	10	18	-	-	-	23.2
SG80S 24L - 0810	24	φ19.2	φ20.8	L1	8	-	φ10 (h7)	L22 R60	90	-	-	-	68.3
SG80S 24B - 0806	24	φ19.2	φ20.8	B1	8	φ 6	φ16	10	18	-	-	-	29.8
SG80S 25L - 0810	25	φ20	φ21.6	L1	8	-	φ10 (h7)	L22 R60	90	-	-	-	69.8
SG80S 25B - 0806	25	φ20	φ21.6	B1	8	φ 6	φ16	10	18	-	-	-	31.3
SG80S 28B - 0808	28	φ22.4	φ24	B1	8	φ 8	φ18	10	18	-	-	-	37.4
SG80S 30B - 0810	30	φ24	φ25.6	B1	8	φ10	φ20	10	18	-	-	-	41.7
SG80S 30B * 0810	30	φ24	φ25.6	B1	8	φ10	φ20	10	18	2-M4	5	-	41.3

セットスクリューはついておりません。 [*] : Gear with Two Thread holes / without Set Screw.
 Gear tooth surface completed with induction hardening, Hardness HRC49 to 55.

許容伝達動力表 曲げ強さ (kW)

Allowable transfer capability table (kW) Bending Strength

歯数 z	歯幅 b	回転速度 (min ⁻¹) revolution/min						
		400	800	1,200	1,500	1,800	2,500	3,000
15	8	0.17	0.35	0.52	0.66	0.79	1.10	1.32
16	8	0.19	0.39	0.58	0.73	0.88	1.22	1.46
18	8	0.23	0.47	0.70	0.88	1.06	1.47	1.76
20	8	0.27	0.55	0.82	1.03	1.24	1.72	2.07
22	8	0.31	0.63	0.95	1.19	1.43	1.98	2.38
24	8	0.36	0.72	1.08	1.35	1.62	2.25	2.70
25	8	0.38	0.76	1.14	1.43	1.71	2.38	2.85
28	8	0.44	0.89	1.34	1.67	2.01	2.79	3.31
30	8	0.49	0.98	1.47	1.84	2.20	3.05	3.61

歯面強さ (kW)

Allowable transfer capability table (kW) Surface Durability

回転速度 (min ⁻¹) revolution/min						
400	800	1,200	1,500	1,800	2,500	3,000
0.036	0.075	0.11	0.13	0.16	0.23	0.28
0.041	0.084	0.12	0.15	0.19	0.26	0.32
0.053	0.107	0.16	0.20	0.24	0.34	0.41
0.066	0.133	0.20	0.25	0.30	0.42	0.51
0.080	0.162	0.24	0.30	0.37	0.52	0.63
0.096	0.193	0.29	0.36	0.44	0.62	0.75
0.104	0.211	0.31	0.40	0.48	0.68	0.82
0.131	0.266	0.40	0.50	0.61	0.86	1.03
0.15	0.30	0.46	0.58	0.70	0.99	1.18

The above numerical values are equivalent to JGMA formulas as reference only.

動力の換算式は P26 をご参照ください。Please refer to the conversion fomulas of power on page P26.

歯研平歯車

GROUND SPUR GEARS

モジュール **0.8** 圧力角 20° (並歯)
 MODULE 20° PRESSURE ANGLE FULL DEPTH TOOTH

歯部高周波焼き入れ HRC49 ~ 55
 JIS B 1702-1 (ISO) 5 級
 System of accuracy: JIS B1702-1(ISO) class 5



御注文には必ず “フルネームで商品記号” を明記してください。
 Please refer to the catalogue reference while ordering.

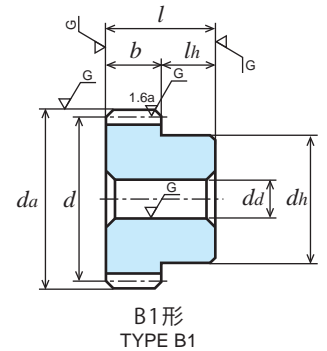
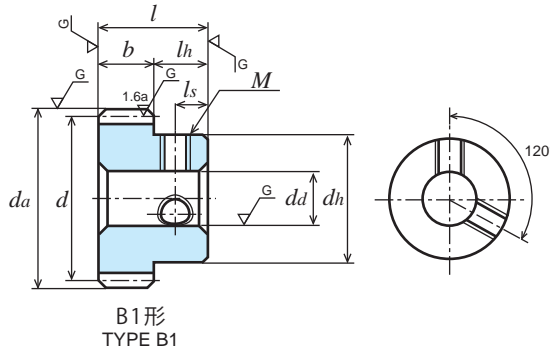

SCM435、440 クロムモリブデン鋼 (JIS G 4053)

Material : Chromium Molybdenum Steel (ISO 34CrMo4, 42CrMo4)

単位 : mm
 Dimensions : mm

商品記号 Catalogue Number	歯数 Number of Teeth z	基準円直径 Reference Diameter d	歯先円直径 Tip Diameter da	形 Type	歯幅 Face Width b	穴径 Bore Diameter da(H7)	ハブ外径 Hub Diameter dh	ハブ長さ Hub Projection lh	全長 Overall Length l	ねじ Set Screw		キリ Tap Guide dr	重量 Weight W(g)
										M	ls		
SG80S 32B - 0810	32	φ25.6	φ27.2	B1	8	φ10	φ20	10	18	-	-	-	45.6
SG80S 35B - 0810	35	φ28	φ29.6	B1	8	φ10	φ20	10	18	-	-	-	51.9
SG80S 36B - 0810	36	φ28.8	φ30.4	B1	8	φ10	φ20	10	18	-	-	-	54.1
SG80S 40B - 0810	40	φ32	φ33.6	B1	8	φ10	φ25	10	18	-	-	-	77.4
SG80S 40B * 0812	40	φ32	φ33.6	B1	8	φ12	φ25	10	18	2-M5	5	-	71.5
SG80S 45B - 0810	45	φ36	φ37.6	B1	8	φ10	φ25	10	18	-	-	-	90.8
SG80S 48B - 0810	48	φ38.4	φ40	B1	8	φ10	φ25	10	18	-	-	-	99.5
SG80S 50B - 0810	50	φ40	φ41.6	B1	8	φ10	φ25	10	18	-	-	-	105.6
SG80S 50B * 0812	50	φ40	φ41.6	B1	8	φ12	φ25	10	18	2-M5	5	-	100.0
SG80S 54B - 0810	54	φ43.2	φ44.8	B1	8	φ10	φ25	10	18	-	-	-	118.7
SG80S 55B - 0810	55	φ44	φ45.6	B1	8	φ10	φ25	10	18	-	-	-	122.1
SG80S 56B - 0810	56	φ44.8	φ46.4	B1	8	φ10	φ25	10	18	-	-	-	125.6
SG80S 60B - 0810	60	φ48	φ49.6	B1	8	φ10	φ25	10	18	-	-	-	140.1
SG80S 60B * 0812	60	φ48	φ49.6	B1	8	φ12	φ25	10	18	2-M5	5	-	134.8

セットスクリューはついておりません。 [*] : Gear with Two Thread holes / without Set Screw.
 Gear tooth surface completed with induction hardening, Hardness HRC49 to 55.

許容伝達動力表 曲げ強さ (kW)

Allowable transfer capability table (kW) Bending Strength

歯数 z	歯幅 b	回転速度 (min ⁻¹) revolution/min						
		400	800	1,200	1,500	1,800	2,500	3,000
32	8	0.53	1.07	1.60	2.00	2.40	3.31	3.91
35	8	0.60	1.20	1.80	2.26	2.71	3.70	4.36
36	8	0.62	1.25	1.87	2.34	2.81	3.83	4.51
40	8	0.71	1.43	2.14	2.68	3.21	4.34	5.10
45	8	0.82	1.65	2.48	3.11	3.69	4.97	5.86
48	8	0.90	1.80	2.70	3.37	3.99	5.35	6.32
50	8	0.94	1.89	2.84	3.53	4.18	5.61	6.63
54	8	1.04	2.08	3.12	3.86	4.56	6.13	7.22
55	8	1.06	2.12	3.19	3.94	4.65	6.25	7.37
56	8	1.08	2.17	3.29	4.02	4.74	6.38	7.52
60	8	1.18	2.36	3.54	4.34	5.12	6.89	8.11

The above numerical values are equivalent to JGMA formulas as reference only.

動力の換算式は P26 をご参照ください。 Please refer to the conversion fomulas of power on page P26.

歯面強さ (kW)

Allowable transfer capability table (kW) Surface Durability

回転速度 (min ⁻¹) revolution/min							
400	800	1,200	1,500	1,800	2,500	3,000	
0.17	0.35	0.53	0.67	0.81	1.13	1.34	
0.20	0.42	0.64	0.80	0.97	1.35	1.61	
0.22	0.44	0.68	0.85	1.03	1.43	1.70	
0.27	0.55	0.84	1.06	1.29	1.76	2.10	
0.35	0.71	1.08	1.36	1.63	2.23	2.66	
0.40	0.81	1.23	1.56	1.86	2.54	3.03	
0.43	0.88	1.34	1.69	2.02	2.76	3.29	
0.51	1.04	1.58	1.98	2.35	3.22	3.84	
0.53	1.08	1.64	2.05	2.44	3.34	3.98	
0.55	1.12	1.70	2.13	2.53	3.47	4.13	
0.63	1.29	1.97	2.44	2.90	3.98	4.74	

目次
CONTENTS

インフォメーション
INFORMATION

ギヤボックス
GEAR BOXES

ノーバッキングギヤ
ANTI BACKLASH SPUR GEARS

歯研平歯車
GROUND SPUR GEARS

平歯車
SPUR GEARS

内歯車
INTERNAL GEARS

歯車ラック
GROUND RACKS

ラック
RACKS

ハニカムギヤ
HELICAL GEARS AND SCREW GEARS

ウォーム
WORMS AND WORM WHEELS

かみ歯車
BEVEL GEARS

スプロケット
SPROCKETS

技術データ
REFERENCE DATA

歯研平歯車

GROUND SPUR GEARS

モジュール **0.8** 圧力角 20° (並歯)
 MODULE 20° PRESSURE ANGLE FULL DEPTH TOOTH

歯部高周波焼き入れ HRC49 ~ 55
 JIS B 1702-1 (ISO) 5 級
 System of accuracy: JIS B1702-1(ISO) class 5



New **ねじを2箇所 (120° 配) にしました。**
締結力が 1.6 倍になりました。
New item with two threaded holes (120°)
Tightening power increased by 1.6 times.

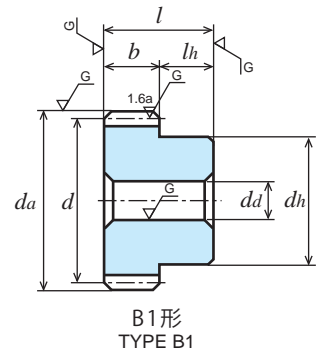
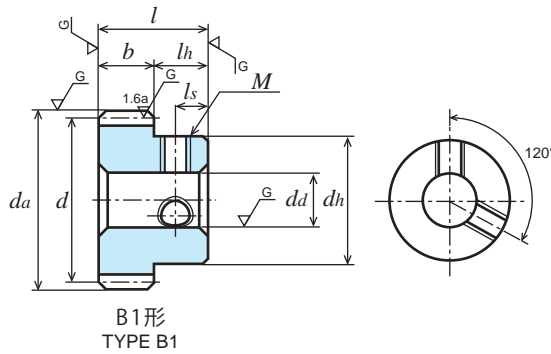

SCM435、440 クロムモリブデン鋼 (JIS G 4053)

Material : Chromium Molybdenum Steel (ISO 34CrMo4, 42CrMo4)

単位 : mm
 Dimensions : mm

商品記号 Catalogue Number	歯数 Number of Teeth z	基準円直径 Reference Diameter d	歯先円直径 Tip Diameter da	形 Type	歯幅 Face Width b	穴径 Bore Diameter da(H7)	ハブ外径 Hub Diameter dh	ハブ長さ Hub Projection lh	全長 Overall Length l	ねじ Set Screw		キリ Tap Guide dr	重量 Weight W(g)
										M	ls		
SG80S 64B - 0812	64	φ51.2	φ52.8	B1	8	φ12	φ30	10	18	-	-	-	167.6
SG80S 70B - 0812	70	φ56	φ57.6	B1	8	φ12	φ30	10	18	-	-	-	192.9
SG80S 72B - 0812	72	φ57.6	φ59.2	B1	8	φ12	φ30	10	18	-	-	-	201.9
SG80S 75B - 0812	75	φ60	φ61.6	B1	8	φ12	φ30	10	18	-	-	-	215.7
SG80S 80B - 0812	80	φ64	φ65.6	B1	8	φ12	φ30	10	18	-	-	-	240.0
SG80S 80B * 0815	80	φ64	φ65.6	B1	8	φ15	φ30	10	18	2-M6	5	-	230.3
SG80S 90B - 0812	90	φ72	φ73.6	B1	8	φ12	φ35	10	18	-	-	-	313.2
SG80S 96B - 0812	96	φ76.8	φ78.4	B1	8	φ12	φ35	10	18	-	-	-	348.2
SG80S 100B - 0812	100	φ80	φ81.6	B1	8	φ12	φ35	10	18	-	-	-	372.8
SG80S 100B * 0820	100	φ80	φ81.6	B1	8	φ20	φ35	10	18	2-M6	5	-	344.9
SG80S 108B - 0812	108	φ86.4	φ88	B1	8	φ12	φ40	10	18	-	-	-	448.0
SG80S 112B - 0812	112	φ89.6	φ91.2	B1	8	φ12	φ40	10	18	-	-	-	475.6
SG80S 120B - 0812	120	φ96	φ97.6	B1	8	φ12	φ40	10	18	-	-	-	533.8
SG80S 120B * 0820	120	φ96	φ97.6	B1	8	φ20	φ40	10	18	2-M6	5	-	506.4

セットスクリューはついておりません。 [*] : Gear with Two Thread holes / without Set Screw.

許容伝達動力表 曲げ強さ (kW)

Allowable transfer capability table (kW) Bending Strength

歯数 z	歯幅 b	回転速度 (min ⁻¹) revolution/min						
		400	800	1,200	1,500	1,800	2,500	3,000
64	8	1.27	2.55	3.80	4.66	5.49	7.39	8.69
70	8	1.42	2.84	4.20	5.14	6.05	8.14	9.50
72	8	1.47	2.93	4.33	5.30	6.24	8.39	9.77
75	8	1.54	3.08	4.53	5.53	6.52	8.76	10.16
80	8	1.66	3.32	4.85	5.92	6.99	9.34	10.80
90	8	1.90	3.79	5.48	6.70	7.90	10.43	12.02
96	8	2.04	4.06	5.85	7.17	8.44	11.07	12.74
100	8	2.14	4.23	6.10	7.48	8.80	11.49	13.25
108	8	2.33	4.59	6.61	8.09	9.50	12.31	14.25
112	8	2.43	4.76	6.86	8.39	9.82	12.71	14.74
120	8	2.62	5.11	7.36	8.99	10.47	13.54	15.70

歯面強さ (kW)

Allowable transfer capability table (kW) Surface Durability

		回転速度 (min ⁻¹) revolution/min						
		400	800	1,200	1,500	1,800	2,500	3,000
64	8	0.72	1.48	2.24	2.78	3.30	4.53	5.38
70	8	0.87	1.79	2.69	3.33	3.96	5.43	6.40
72	8	0.93	1.89	2.85	3.52	4.19	5.74	6.75
75	8	1.01	2.06	3.09	3.82	4.55	6.22	7.30
80	8	1.15	2.36	3.52	4.34	5.18	7.06	8.25
90	8	1.47	3.02	4.45	5.51	6.56	8.83	10.29
96	8	1.68	3.43	5.06	6.27	7.46	9.98	11.61
100	8	1.83	3.73	5.48	6.80	8.09	10.78	12.56
108	8	2.15	4.35	6.40	7.94	9.42	12.45	14.57
112	8	2.32	4.68	6.89	8.54	10.10	13.33	15.62
120	8	2.68	5.37	7.92	9.80	11.53	15.20	17.82

The above numerical values are equivalent to JGMA formulas as reference only.

動力の換算式は P26 をご参照ください。Please refer to the conversion fomulas of power on page P26.

歯研平歯車

GROUND SPUR GEARS

モジュール
MODULE

1

圧力角 20° (並歯)
20° PRESSURE ANGLE FULL DEPTH TOOTH

歯部高周波焼き入れ HRC49 ~ 55
JIS B 1702-1 (ISO) 5 級
System of accuracy: JIS B1702-1(ISO) class 5

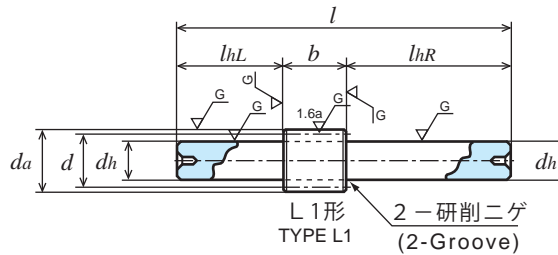

SCM435、440 クロムモリブデン鋼 (JIS G 4053)

Material : Chromium Molybdenum Steel (ISO 34CrMo4, 42CrMo4)

単位 : mm
Dimensions : mm

商品記号 Catalogue Number	歯数 Number of Teeth z	基準円直径 Reference Diameter d	歯先円直径 Tip Diameter da	形 Type	歯幅 Face Width b	穴径 Bore Diameter da(H7)	ハブ外径 Hub Diameter dh	ハブ長さ Hub Projection lh	全長 Overall Length l	ねじ Set Screw		キリ Tap Guide dr	重量 Weight W(g)
										M	ls		
SG1S 14L - 1008	14	φ14	φ16	L1	10	-	φ 8 (h7)	L25 R60	95	-	-	-	45.3
SG1S 15L - 1010	15	φ15	φ17	L1	10	-	φ10 (h7)	L25 R60	95	-	-	-	65.9
SG1S 16L - 1010	16	φ16	φ18	L1	10	-	φ10 (h7)	L25 R60	95	-	-	-	67.8
SG1S 17B - 1006	17	φ17	φ19	B1	10	φ 6	φ12	10	20	-	-	-	22.1
SG1S 18L - 1010	18	φ18	φ20	L1	10	-	φ10 (h7)	L25 R60	95	-	-	-	71.9
SG1S 18B - 1008	18	φ18	φ20	B1	10	φ 8	φ15	10	20	-	-	-	25.8
SG1S 20B - 1008	20	φ20	φ22	B1	10	φ 8	φ16	10	20	-	-	-	32.3
SG1S 20B * 1008	20	φ20	φ22	B1	10	φ 8	φ16	10	20	2-M4	5	-	32.0
SG1S 20B * 1010	20	φ20	φ22	B1	10	φ10	φ16	10	20	2-M4	5	-	27.7
SG1S 21B - 1008	21	φ21	φ23	B1	10	φ 8	φ16	10	20	-	-	-	34.9
SG1S 22B - 1008	22	φ22	φ24	B1	10	φ 8	φ18	10	20	-	-	-	41.7
SG1S 23B - 1008	23	φ23	φ25	B1	10	φ 8	φ18	10	20	-	-	-	44.4

セットスクリューはついておりません。 [*] : Gear with Two Thread holes / without Set Screw.
Gear tooth surface completed with induction hardening, Hardness HRC49 to 55.

許容伝達動力表 曲げ強さ (kW)

Allowable transfer capability table (kW) Bending Strength

歯数 z	歯幅 b	回転速度 (min ⁻¹) revolution/min						
		400	800	1,200	1,500	1,800	2,500	3,000
14	10	0.30	0.61	0.92	1.15	1.38	1.92	2.30
15	10	0.34	0.68	1.03	1.29	1.55	2.15	2.58
16	10	0.38	0.76	1.14	1.43	1.72	2.39	2.87
17	10	0.42	0.84	1.26	1.57	1.89	2.63	3.15
18	10	0.46	0.92	1.38	1.72	2.07	2.87	3.45
20	10	0.54	1.08	1.62	2.02	2.43	3.37	4.03
21	10	0.58	1.16	1.74	2.17	2.61	3.62	4.32
22	10	0.62	1.24	1.86	2.33	2.79	3.88	4.60
23	10	0.66	1.32	1.98	2.48	2.98	4.14	4.89

The above numerical values are equivalent to JGMA formulas as reference only.

動力の換算式は P26 をご参照ください。 Please refer to the conversion fomulas of power on page P26.

歯面強さ (kW)

Allowable transfer capability table (kW) Surface Durability

回転速度 (min ⁻¹) revolution/min						
400	800	1,200	1,500	1,800	2,500	3,000
0.062	0.12	0.19	0.23	0.28	0.40	0.48
0.072	0.14	0.22	0.27	0.33	0.46	0.56
0.082	0.16	0.25	0.31	0.38	0.53	0.64
0.093	0.18	0.28	0.35	0.43	0.60	0.73
0.105	0.21	0.32	0.40	0.48	0.68	0.82
0.130	0.26	0.39	0.50	0.60	0.85	1.02
0.144	0.29	0.44	0.55	0.67	0.94	1.13
0.158	0.32	0.48	0.61	0.73	1.03	1.24
0.174	0.35	0.53	0.67	0.81	1.14	1.35

目次
CONTENTS

インフォメーション
INFORMATION

ギヤボックス
GEAR BOXES

ノーバッキングギヤ
ANTI BACKLASH SPUR GEARS

歯研平歯車
GROUND SPUR GEARS

平歯車
SPUR GEARS

内歯車
INTERNAL GEARS

歯車ラック
GROUND RACKS

ラック
RACKS

斜歯車とスクリューギヤ
HELICAL GEARS AND SCREW GEARS

ワームとワームホイール
WORMS AND WORM WHEELS

かさ歯車
BEVEL GEARS

スプロケット
SPROCKETS

技術資料
REFERENCE DATA

歯研平歯車

GROUND SPUR GEARS

モジュール
MODULE

1

圧力角 20° (並歯)

20° PRESSURE ANGLE FULL DEPTH TOOTH

歯部高周波焼き入れ HRC49 ~ 55
JIS B 1702-1 (ISO) 5 級
System of accuracy: JIS B1702-1(ISO) class 5



New **ねじを2箇所 (120° 配) にしました。**
締結力が 1.6 倍になりました。
New item with two threaded holes (120°)
Tightening power increased by 1.6 times.

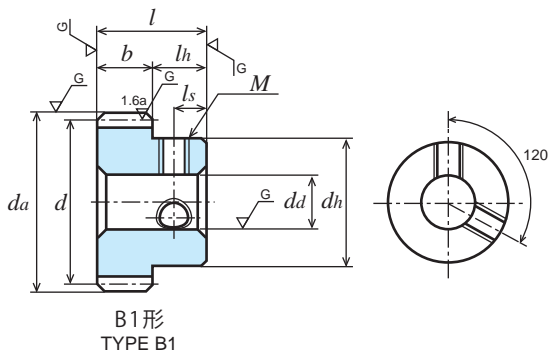

SCM435、440 クロムモリブデン鋼 (JIS G 4053)

Material : Chromium Molybdenum Steel (ISO 34CrMo4, 42CrMo4)

単位 : mm
Dimensions : mm

商品記号 Catalogue Number	歯数 Number of Teeth z	基準円直径 Reference Diameter d	歯先円直径 Tip Diameter da	形 Type	歯幅 Face Width b	穴径 Bore Diameter da(H7)	ハブ外径 Hub Diameter dh	ハブ長さ Hub Projection lh	全長 Overall Length l	ねじ Set Screw		キリ Tap Guide dr	重量 Weight W(g)
										M	ls		
SG1S 24B - 1008	24	φ24	φ26	B1	10	φ 8	φ20	10	20	-	-	-	51.9
SG1S 24B * 1008	24	φ24	φ26	B1	10	φ 8	φ20	10	20	2-M4	5	-	51.4
SG1S 24B * 1010	24	φ24	φ26	B1	10	φ10	φ20	10	20	2-M4	5	-	47.1
SG1S 25B - 1008	25	φ25	φ27	B1	10	φ 8	φ20	10	20	-	-	-	55.0
SG1S 26B - 1008	26	φ26	φ28	B1	10	φ 8	φ20	10	20	-	-	-	58.1
SG1S 27B - 1008	27	φ27	φ29	B1	10	φ 8	φ20	10	20	-	-	-	61.3
SG1S 28B - 1008	28	φ28	φ30	B1	10	φ 8	φ20	10	20	-	-	-	64.7
SG1S 30B - 1010	30	φ30	φ32	B1	10	φ10	φ26	10	20	-	-	-	84.3
SG1S 30B * 1010	30	φ30	φ32	B1	10	φ10	φ26	10	20	2-M4	5	-	83.7
SG1S 30B * 1012	30	φ30	φ32	B1	10	φ12	φ26	10	20	2-M4	5	-	78.5
SG1S 32B - 1010	32	φ32	φ34	B1	10	φ10	φ26	10	20	-	-	-	91.9
SG1S 34B - 1010	34	φ34	φ36	B1	10	φ10	φ26	10	20	-	-	-	100.0

セットスクリューはついておりません。 [*] : Gear with Two Thread holes / without Set Screw.
Gear tooth surface completed with induction hardening, Hardness HRC49 to 55.

許容伝達動力表 曲げ強さ (kW)

Allowable transfer capability table (kW) Bending Strength

歯数 z	歯幅 b	回転速度 (min ⁻¹) revolution/min						
		400	800	1,200	1,500	1,800	2,500	3,000
24	10	0.70	1.40	2.11	2.64	3.16	4.38	5.18
25	10	0.74	1.49	2.23	2.79	3.35	4.63	5.46
26	10	0.78	1.57	2.36	2.95	3.54	4.87	5.75
27	10	0.83	1.66	2.49	3.11	3.73	5.12	6.04
28	10	0.87	1.74	2.62	3.27	3.93	5.37	6.33
30	10	0.95	1.91	2.87	3.59	4.31	5.85	6.89
32	10	1.04	2.09	3.13	3.92	4.70	6.34	7.46
34	10	1.13	2.26	3.40	4.25	5.07	6.83	8.05

歯面強さ (kW)

Allowable transfer capability table (kW) Surface Durability

回転速度 (min ⁻¹) revolution/min							
400	800	1,200	1,500	1,800	2,500	3,000	
0.190	0.38	0.58	0.73	0.88	1.24	1.48	
0.20	0.41	0.63	0.79	0.96	1.34	1.60	
0.22	0.45	0.68	0.86	1.04	1.45	1.73	
0.24	0.49	0.74	0.93	1.13	1.57	1.87	
0.26	0.52	0.80	1.01	1.22	1.69	2.01	
0.30	0.61	0.92	1.16	1.41	1.94	2.31	
0.34	0.69	1.05	1.33	1.61	2.21	2.62	
0.38	0.79	1.20	1.51	1.82	2.49	2.96	

The above numerical values are equivalent to JGMA formulas as reference only.

動力の換算式は P26 をご参照ください。Please refer to the conversion fomulas of power on page P26.

歯研平歯車

GROUND SPUR GEARS

モジュール
MODULE

1

圧力角 20° (並歯)
20° PRESSURE ANGLE FULL DEPTH TOOTH

歯部高周波焼き入れ HRC49 ~ 55
JIS B 1702-1 (ISO) 5 級
System of accuracy: JIS B1702-1(ISO) class 5



御注文には必ず“フルネームで商品記号”を明記してください。
Please refer to the catalogue reference while ordering.

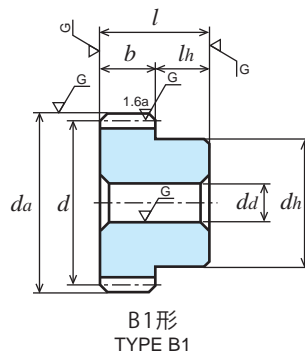

SCM435、440 クロムモリブデン鋼 (JIS G 4053)

Material : Chromium Molybdenum Steel (ISO 34CrMo4, 42CrMo4)

単位 : mm
Dimensions : mm

商品記号 Catalogue Number	歯数 Number of Teeth <i>z</i>	基準円直径 Reference Diameter <i>d</i>	歯先円直径 Tip Diameter <i>da</i>	形 Type	歯幅 Face Width <i>b</i>	穴径 Bore Diameter <i>da</i> (H7)	ハブ外径 Hub Diameter <i>dh</i>	ハブ長さ Hub Projection <i>lh</i>	全長 Overall Length <i>l</i>	ねじ Set Screw		キリ Tap Guide <i>dr</i>	重量 Weight <i>W</i> (g)
										<i>M</i>	<i>ls</i>		
SG1S 35B - 1010	35	φ35	φ37	B1	10	φ10	φ26	10	20	-	-	-	104.2
SG1S 36B - 1010	36	φ36	φ38	B1	10	φ10	φ26	10	20	-	-	-	108.6
SG1S 38B - 1010	38	φ38	φ40	B1	10	φ10	φ26	10	20	-	-	-	117.6
SG1S 40B - 1010	40	φ40	φ42	B1	10	φ10	φ26	10	20	-	-	-	127.1
SG1S 40B - 1012	40	φ40	φ42	B1	10	φ12	φ26	10	20	-	-	-	121.7
SG1S 40B - 1015	40	φ40	φ42	B1	10	φ15	φ26	10	20	-	-	-	111.8
SG1S 42B - 1010	42	φ42	φ44	B1	10	φ10	φ35	10	20	-	-	-	170.9
SG1S 44B - 1010	44	φ44	φ46	B1	10	φ10	φ35	10	20	-	-	-	181.4
SG1S 45B - 1012	45	φ45	φ47	B1	10	φ12	φ35	10	20	-	-	-	181.5
SG1S 48B - 1012	48	φ48	φ50	B1	10	φ12	φ35	10	20	-	-	-	198.5
SG1S 50B - 1012	50	φ50	φ52	B1	10	φ12	φ35	10	20	-	-	-	210.6
SG1S 50B - 1015	50	φ50	φ52	B1	10	φ15	φ35	10	20	-	-	-	200.6
SG1S 50B - 1016	50	φ50	φ52	B1	10	φ16	φ35	10	20	-	-	-	196.8

Gear tooth surface completed with induction hardening, Hardness HRC49 to 55.

許容伝達動力表 曲げ強さ (kW)

Allowable transfer capability table (kW) Bending Strength

歯数 <i>z</i>	歯幅 <i>b</i>	回転速度 (min ⁻¹) revolution/min						
		400	800	1,200	1,500	1,800	2,500	3,000
35	10	1.17	2.35	3.53	4.41	5.25	7.07	8.34
36	10	1.22	2.44	3.66	4.58	5.44	7.32	8.63
38	10	1.31	2.62	3.93	4.93	5.81	7.80	9.21
40	10	1.40	2.88	4.20	5.23	6.18	8.30	9.80
42	10	1.49	2.98	4.47	5.54	6.54	8.79	10.37
44	10	1.58	3.16	4.73	5.85	6.90	9.28	10.94
45	10	1.62	3.25	4.87	6.01	7.08	9.53	11.23
48	10	1.76	3.52	5.27	6.47	7.62	10.26	12.08
50	10	1.85	3.70	5.53	6.78	7.98	10.75	12.64

The above numerical values are equivalent to JGMA formulas as reference only.

動力の換算式は P26 をご参照ください。Please refer to the conversion fomulas of power on page P26.

歯面強さ (kW)

Allowable transfer capability table (kW) Surface Durability

回転速度 (min ⁻¹) revolution/min						
400	800	1,200	1,500	1,800	2,500	3,000
0.41	0.83	1.27	1.60	1.93	2.64	3.14
0.43	0.89	1.35	1.70	2.04	2.79	3.33
0.49	0.99	1.51	1.91	2.27	3.11	3.71
0.54	1.11	1.69	2.12	2.53	3.45	4.12
0.60	1.23	1.87	2.34	2.79	3.81	4.54
0.66	1.35	2.06	2.57	3.06	4.18	4.98
0.69	1.42	2.16	2.69	3.20	4.38	5.21
0.79	1.62	2.47	3.06	3.64	4.98	5.93
0.86	1.76	2.68	3.32	3.94	5.41	6.43

目次
CONTENTS

インフォメーション
INFORMATION

ギヤボックス
GEAR BOXES

ノーバッキングギヤ
ANTI BACKLASH SPUR GEARS

歯研平歯車
GROUND SPUR GEARS

平歯車
SPUR GEARS

内歯車
INTERNAL GEARS

歯研ラック
GROUND RACKS

ラック
RACKS

ハニカムギヤ
HELICAL GEARS AND SCREW GEARS

ワーム
WORMS AND WORM WHEELS

かさ歯車
BEVEL GEARS

スプロケット
SPROCKETS

技術資料
REFERENCE DATA

歯研平歯車

GROUND SPUR GEARS

モジュール
MODULE

1

圧力角 20° (並歯)
20° PRESSURE ANGLE FULL DEPTH TOOTH

歯部高周波焼き入れ HRC49 ~ 55
JIS B 1702-1 (ISO) 5 級
System of accuracy: JIS B1702-1(ISO) class 5

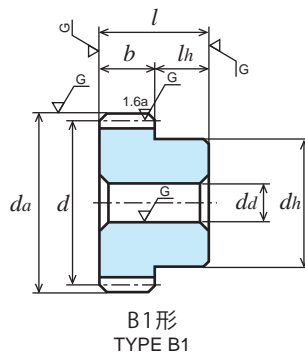

SCM435、440 クロムモリブデン鋼 (JIS G 4053)

Material : Chromium Molybdenum Steel (ISO 34CrMo4, 42CrMo4)

単位 : mm
Dimensions : mm

商品記号 Catalogue Number	歯数 Number of Teeth <i>z</i>	基準円直径 Reference Diameter <i>d</i>	歯先円直径 Tip Diameter <i>da</i>	形 Type	歯幅 Face Width <i>b</i>	穴径 Bore Diameter <i>dd</i> (H7)	ハブ外径 Hub Diameter <i>dh</i>	ハブ長さ Hub Projection <i>lh</i>	全長 Overall Length <i>l</i>	ねじ Set Screw		キリ Tap Guide <i>dr</i>	重量 Weight <i>W</i> (g)
										<i>M</i>	<i>ls</i>		
SG1S 52B - 1012	52	φ52	φ54	B1	10	φ12	φ35	10	20	-	-	-	228.4
SG1S 54B - 1012	54	φ54	φ56	B1	10	φ12	φ35	10	20	-	-	-	236.0
SG1S 55B - 1012	55	φ55	φ57	B1	10	φ12	φ35	10	20	-	-	-	248.1
SG1S 56B - 1012	56	φ56	φ58	B1	10	φ12	φ35	10	20	-	-	-	249.5
SG1S 60B - 1012	60	φ60	φ62	B1	10	φ12	φ40	10	20	-	-	-	300.9
SG1S 60B - 1015	60	φ60	φ62	B1	10	φ15	φ40	10	20	-	-	-	291.0
SG1S 60B - 1018	60	φ60	φ62	B1	10	φ18	φ40	10	20	-	-	-	278.9
SG1S 64B - 1012	64	φ64	φ66	B1	10	φ12	φ40	10	20	-	-	-	331.3
SG1S 70B - 1012	70	φ70	φ72	B1	10	φ12	φ40	10	20	-	-	-	380.6
SG1S 72B - 1012	72	φ72	φ74	B1	10	φ12	φ45	10	20	-	-	-	424.0
SG1S 75B - 1012	75	φ75	φ77	B1	10	φ12	φ45	10	20	-	-	-	451.0

Gear tooth surface completed with induction hhardening, Hardness HRC49 to 55.

許容伝達動力表 曲げ強さ (kW)

Allowable transfer capability table (kW) Bending Strength

歯数 <i>z</i>	歯幅 <i>b</i>	回転速度 (min ⁻¹) revolution/min						
		400	800	1,200	1,500	1,800	2,500	3,000
52	10	1.94	3.88	5.78	7.09	8.34	11.23	13.18
54	10	2.03	4.06	6.04	7.39	8.70	11.71	13.71
55	10	2.08	4.16	6.16	7.54	8.88	11.95	13.97
56	10	2.12	4.25	6.29	7.70	9.06	12.19	14.23
60	10	2.31	4.62	6.79	8.30	9.79	13.14	15.24
64	10	2.49	4.99	7.29	8.90	10.51	14.04	16.24
70	10	2.77	5.54	8.03	9.82	11.58	15.34	17.69
72	10	2.86	5.73	8.28	10.12	11.94	15.76	18.16
75	10	3.00	5.99	8.64	10.58	12.47	16.39	18.86

歯面強さ (kW)

Allowable transfer capability table (kW) Surface Durability

回転速度 (min ⁻¹) revolution/min							
400	800	1,200	1,500	1,800	2,500	3,000	
0.94	1.91	2.90	3.59	4.26	5.85	6.94	
1.01	2.07	3.13	3.87	4.60	6.31	7.46	
1.05	2.15	3.24	4.01	4.77	6.54	7.73	
1.09	2.23	3.36	4.16	4.95	6.78	8.00	
1.26	2.58	3.86	4.77	5.69	7.78	9.12	
1.44	2.95	4.39	5.43	6.47	8.82	10.31	
1.73	3.56	5.26	6.50	7.75	10.47	12.20	
1.84	3.77	5.56	6.88	8.20	11.04	12.86	
2.00	4.09	6.03	7.47	8.90	11.93	13.88	

The above numerical values are equivalent to JGMA formulas as reference only.

動力の換算式は P26 をご参照ください。Please refer to the conversion fomulas of power on page P26.

歯研平歯車 GROUND SPUR GEARS

モジュール
MODULE

1

圧力角 20° (並歯)
20° PRESSURE ANGLE FULL DEPTH TOOTH

歯部高周波焼き入れ HRC49 ~ 55
JIS B 1702-1 (ISO) 5 級
System of accuracy: JIS B1702-1(ISO) class 5



御注文には必ず“フルネームで商品記号”を明記してください。
Please refer to the catalogue reference while ordering.

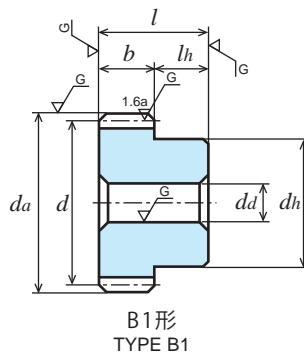

SCM435、440 クロムモリブデン鋼 (JIS G 4053) Material : Chromium Molybdenum Steel (ISO 34CrMo4, 42CrMo4)

単位 : mm
Dimensions : mm

商品記号 Catalogue Number	歯数 Number of Teeth <i>z</i>	基準円直径 Reference Diameter <i>d</i>	歯先円直径 Tip Diameter <i>da</i>	形 Type	歯幅 Face Width <i>b</i>	穴径 Bore Diameter <i>da</i> (H7)	ハブ外径 Hub Diameter <i>dh</i>	ハブ長さ Hub Projection <i>lh</i>	全長 Overall Length <i>l</i>	ねじ Set Screw		キリ Tap Guide <i>dr</i>	重量 Weight <i>W</i> (g)
										<i>M</i>	<i>ls</i>		
SG1S 80B - 1012	80	φ 80	φ 82	B1	10	φ12	φ45	10	20	-	-	-	498.5
SG1S 80B - 1015	80	φ 80	φ 82	B1	10	φ15	φ45	10	20	-	-	-	488.6
SG1S 80B - 1020	80	φ 80	φ 82	B1	10	φ20	φ45	10	20	-	-	-	467.1
SG1S 90B - 1015	90	φ 90	φ 92	B1	10	φ15	φ50	10	20	-	-	-	621.8
SG1S 96B - 1015	96	φ 96	φ 98	B1	10	φ15	φ50	10	20	-	-	-	690.2
SG1S 100B - 1012	100	φ100	φ102	B1	10	φ12	φ50	10	20	-	-	-	748.1
SG1S 100B - 1015	100	φ100	φ102	B1	10	φ15	φ50	10	20	-	-	-	738.2
SG1S 100B - 1020	100	φ100	φ102	B1	10	φ20	φ50	10	20	-	-	-	716.8
SG1S 108B - 1015	108	φ108	φ110	B1	10	φ15	φ50	10	20	-	-	-	840.1
SG1S 112B - 1015	112	φ112	φ114	B1	10	φ15	φ50	10	20	-	-	-	894.0
SG1S 120B - 1015	120	φ120	φ122	B1	10	φ15	φ50	10	20	-	-	-	1007.7

Gear tooth surface completed with induction hardening, Hardness HRC49 to 55.

許容伝達動力表 曲げ強さ (kW)

Allowable transfer capability table (kW) Bending Strength

歯数 <i>z</i>	歯幅 <i>b</i>	回転速度 (min ⁻¹) revolution/min						
		400	800	1,200	1,500	1,800	2,500	3,000
80	10	3.24	6.42	9.25	11.33	13.34	17.42	20.08
90	10	3.70	7.26	10.47	12.80	14.98	19.37	22.47
96	10	3.98	7.77	11.20	13.68	15.92	20.59	23.88
100	10	4.17	8.10	11.68	14.25	16.53	21.40	24.80
108	10	4.55	8.76	12.64	15.34	17.73	23.01	26.60
112	10	4.74	9.09	13.11	15.86	18.32	23.80	27.48
120	10	5.12	9.74	14.05	16.89	19.46	25.34	28.97

The above numerical values are equivalent to JGMA formulas as reference only.

動力の換算式は P26 をご参照ください。Please refer to the conversion fomulas of power on page P26.

歯面強さ (kW)

Allowable transfer capability table (kW) Surface Durability

回転速度 (min ⁻¹) revolution/min							
400	800	1,200	1,500	1,800	2,500	3,000	
2.29	4.66	6.85	8.51	10.12	13.48	15.70	
2.92	5.90	8.69	10.77	12.74	16.80	19.69	
3.34	6.72	9.90	12.25	14.41	19.00	22.28	
3.64	7.29	10.74	13.28	15.57	20.56	24.07	
4.27	8.50	12.53	15.42	18.01	23.84	27.84	
4.61	9.13	13.48	16.53	19.29	25.55	29.80	
5.32	10.48	15.47	18.85	21.95	29.13	33.64	

目次
CONTENTS

インフォメーション
INFORMATION

ギヤボックス
GEAR BOXES

ノーバッキングギヤ
ANTI BACKLASH SPUR GEARS

歯研平歯車
GROUND SPUR GEARS

平歯車
SPUR GEARS

内歯車
INTERNAL GEARS

歯研ラック
GROUND RACKS

ラック
RACKS

へリカル・スクリューギヤ
HELICAL GEARS AND SCREW GEARS

ウォーム・ウォームギヤ
WORMS AND WORM GEARS

かさ歯車
BEVEL GEARS

スプロケット
SPROCKETS

技術資料
REFERENCE DATA

歯研平歯車

GROUND SPUR GEARS

モジュール **1.5** 圧力角 20° (並歯)
 MODULE 20° PRESSURE ANGLE FULL DEPTH TOOTH

歯部高周波焼き入れ HRC49 ~ 55
 JIS B 1702-1 (ISO) 5 級相当
 System of accuracy: JIS B1702-1(ISO) class 5

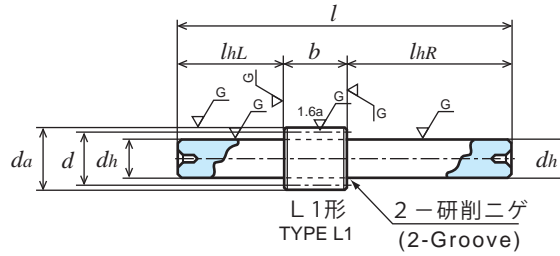

SCM435、440 クロムモリブデン鋼 (JIS G 4053)

Material : Chromium Molybdenum Steel (ISO 34CrMo4, 42CrMo4)

単位 : mm
 Dimensions : mm

商品記号 Catalogue Number	歯数 Number of Teeth <i>z</i>	基準円直径 Reference Diameter <i>d</i>	歯先円直径 Tip Diameter <i>da</i>	形 Type	歯幅 Face Width <i>b</i>	穴径 Bore Diameter <i>da</i> (H7)	ハブ外径 Hub Diameter <i>dh</i>	ハブ長さ Hub Projection <i>lh</i>	全長 Overall Length <i>l</i>	重量 Weight <i>W</i> (kg)
SG1.5S 14L - 1512	14	φ21	φ24	L1	15	-	φ12(h7)	L25 R60	100	0.12
SG1.5S 15L - 1512	15	φ22.5	φ25.5	L1	15	-	φ12(h7)	L25 R60	100	0.12
SG1.5S 15B - 1510	15	φ22.5	φ25.5	B1	15	φ10	φ18	15	30	0.06
SG1.5S 16L - 1512	16	φ24	φ27	L1	15	-	φ12(h7)	L25 R60	100	0.13
SG1.5S 16B - 1510	16	φ24	φ27	B1	15	φ10	φ18	15	30	0.06
SG1.5S 18L - 1512	18	φ27	φ30	L1	15	-	φ12(h7)	L25 R60	100	0.14
SG1.5S 18B - 1512	18	φ27	φ30	B1	15	φ12	φ22	15	30	0.08
SG1.5S 20B - 1512	20	φ30	φ33	B1	15	φ12	φ22	15	30	0.10
SG1.5S 22B - 1512	22	φ33	φ36	B1	15	φ12	φ25	15	30	0.13
SG1.5S 24B - 1515	24	φ36	φ39	B1	15	φ15	φ30	15	30	0.16
SG1.5S 25B - 1515	25	φ37.5	φ40.5	B1	15	φ15	φ30	15	30	0.17

Gear tooth surface completed with induction hardening, Hardness HRC49 to 55.

許容伝達動力表 曲げ強さ (kW)

Allowable transfer capability table (kW) Bending Strength

歯数 <i>z</i>	歯幅 <i>b</i>	回転速度 (min ⁻¹) revolution/min						
		400	800	1,200	1,500	1,800	2,500	3,000
14	15	1.03	2.07	3.11	3.89	4.67	6.49	7.73
15	15	1.16	2.32	3.49	4.36	5.23	7.27	8.61
16	15	1.29	2.58	3.87	4.84	5.81	8.04	9.50
18	15	1.55	3.11	4.66	5.82	6.99	9.58	11.30
20	15	1.82	3.65	5.47	6.84	8.20	11.14	13.11
22	15	2.10	4.20	6.29	7.87	9.41	12.69	14.94
24	15	2.38	4.75	7.13	8.91	10.59	14.25	16.80
25	15	2.52	5.04	7.55	9.44	11.18	15.02	17.74

The above references are JGMA standard.

動力の換算式は P26 をご参照ください。Please refer to the conversion fomulas of power on page P26.

歯面強さ (kW)

Allowable transfer capability table (kW) Surface Durability

回転速度 (min ⁻¹) revolution/min						
400	800	1,200	1,500	1,800	2,500	3,000
0.21	0.43	0.66	0.83	1.00	1.41	1.69
0.24	0.50	0.76	0.96	1.16	1.63	1.95
0.28	0.57	0.87	1.09	1.32	1.86	2.20
0.36	0.74	1.12	1.41	1.70	2.36	2.81
0.45	0.92	1.39	1.75	2.12	2.92	3.47
0.55	1.11	1.69	2.14	2.57	3.53	4.19
0.66	1.34	2.03	2.56	3.07	4.19	5.00
0.72	1.45	2.21	2.79	3.33	4.55	5.42

歯研平歯車

GROUND SPUR GEARS

モジュール **1.5** 圧力角 20° (並歯)
 MODULE 20° PRESSURE ANGLE FULL DEPTH TOOTH

歯部高周波焼き入れ HRC49 ~ 55
 JIS B 1702-1 (ISO) 5 級
 System of accuracy: JIS B1702-1(ISO) class 5



御注文には必ず“フルネームで商品記号”を明記してください。
 Please refer to the catalogue reference while ordering.

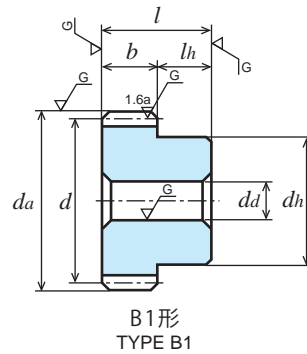

SCM435、440 クロムモリブデン鋼 (JIS G 4053)

Material : Chromium Molybdenum Steel (ISO 34CrMo4, 42CrMo4)

単位 : mm
 Dimensions : mm

商品記号 Catalogue Number	歯数 Number of Teeth <i>z</i>	基準円直径 Reference Diameter <i>d</i>	歯先円直径 Tip Diameter <i>da</i>	形 Type	歯幅 Face Width <i>b</i>	穴径 Bore Diameter <i>da</i> (H7)	ハブ外径 Hub Diameter <i>dh</i>	ハブ長さ Hub Projection <i>lh</i>	全長 Overall Length <i>l</i>	重量 Weight <i>W</i> (kg)
SG1.5S 26B - 1515	26	φ39	φ42	B1	15	φ15	φ30	15	30	0.18
SG1.5S 28B - 1515	28	φ42	φ45	B1	15	φ15	φ30	15	30	0.20
SG1.5S 30B - 1515	30	φ45	φ48	B1	15	φ15	φ35	15	30	0.26
SG1.5S 32B - 1515	32	φ48	φ51	B1	15	φ15	φ35	15	30	0.28
SG1.5S 34B - 1515	34	φ51	φ54	B1	15	φ15	φ35	15	30	0.31
SG1.5S 35B - 1515	35	φ52.5	φ55.5	B1	15	φ15	φ35	15	30	0.36
SG1.5S 36B - 1515	36	φ54	φ57	B1	15	φ15	φ40	15	30	0.37
SG1.5S 40B - 1515	40	φ60	φ63	B1	15	φ15	φ40	15	30	0.44
SG1.5S 42B - 1515	42	φ63	φ66	B1	15	φ15	φ40	15	30	0.47
SG1.5S 45B - 1520	45	φ67.5	φ70.5	B1	15	φ20	φ50	15	30	0.57
SG1.5S 48B - 1520	48	φ72	φ75	B1	15	φ20	φ50	15	30	0.63

Gear tooth surface completed with induction hardening, Hardness HRC49 to 55.

許容伝達動力表 曲げ強さ (kW)

Allowable transfer capability table (kW) Bending Strength

歯数 <i>z</i>	歯幅 <i>b</i>	回転速度 (min ⁻¹) revolution/min						
		400	800	1,200	1,500	1,800	2,500	3,000
26	15	2.66	5.32	7.98	9.96	11.77	15.81	18.67
28	15	2.95	5.90	8.84	10.97	12.96	17.41	20.54
30	15	3.24	6.47	9.71	11.98	14.13	19.00	22.39
32	15	3.53	7.06	10.59	12.99	15.30	20.59	24.24
34	15	3.83	7.65	11.42	13.99	16.47	22.18	26.08
35	15	3.97	7.95	11.83	14.49	17.05	22.97	26.94
36	15	4.12	8.25	12.25	15.00	17.64	23.76	27.81
40	15	4.72	9.45	13.90	16.98	20.03	26.90	31.19
42	15	5.03	10.05	14.72	17.97	21.22	28.40	32.85
45	15	5.48	10.96	15.94	19.47	22.98	30.55	35.27
48	15	5.94	11.87	17.16	20.98	24.74	32.67	37.64

The above references are JGMA standard.

動力の換算式は P26 をご参照ください。Please refer to the conversion formulas of power on page P26.

歯面強さ (kW)

Allowable transfer capability table (kW) Surface Durability

回転速度 (min ⁻¹) revolution/min							
400	800	1,200	1,500	1,800	2,500	3,000	
0.78	1.58	2.40	3.02	3.60	4.92	5.87	
0.90	1.84	2.80	3.51	4.18	5.71	6.81	
1.04	2.12	3.23	4.03	4.80	6.57	7.82	
1.19	2.43	3.70	4.59	5.45	7.47	8.89	
1.35	2.75	4.18	5.18	6.15	8.44	10.03	
1.43	2.93	4.43	5.49	6.52	8.94	10.60	
1.52	3.10	4.69	5.80	6.90	9.46	11.19	
1.89	3.87	5.79	7.16	8.53	11.67	13.69	
2.09	4.28	6.39	7.89	9.41	12.83	15.01	
2.41	4.94	7.33	9.06	10.81	14.65	17.10	
2.76	5.66	8.34	10.32	12.30	16.56	19.29	

目次
CONTENTS

インフォメーション
INFORMATION

ギヤボックス
GEAR BOXES

ノーバッキングギヤ
ANTI BACKLASH SPUR GEARS

歯研平歯車
GROUND SPUR GEARS

平歯車
SPUR GEARS

内歯車
INTERNAL GEARS

歯研ラック
GROUND RACKS

ラック
RACKS

へリカル・スクリューギヤ
HELICAL GEARS AND SCREW GEARS

ウォーム・ウォームギヤ
WORMS AND WORM GEARS

かさ歯車
BEVEL GEARS

スプロケット
SPROCKETS

技術データ
REFERENCE DATA

歯研平歯車

GROUND SPUR GEARS

モジュール **1.5** 圧力角 20° (並歯)
 MODULE 20° PRESSURE ANGLE FULL DEPTH TOOTH

歯部高周波焼き入れ HRC49 ~ 55
 JIS B 1702-1 (ISO) 5 級
 System of accuracy: JIS B1702-1(ISO) class 5

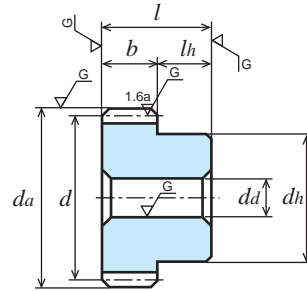

B1形
TYPE B1

SCM435、440 クロムモリブデン鋼 (JIS G 4053)

Material : Chromium Molybdenum Steel (ISO 34CrMo4, 42CrMo4)

単位 : mm
Dimensions : mm

商品記号 Catalogue Number	歯数 Number of Teeth <i>z</i>	基準円直径 Reference Diameter <i>d</i>	歯先円直径 Tip Diameter <i>da</i>	形 Type	歯幅 Face Width <i>b</i>	穴径 Bore Diameter <i>da</i> (H7)	ハブ外径 Hub Diameter <i>dh</i>	ハブ長さ Hub Projection <i>lh</i>	全長 Overall Length <i>l</i>	重量 Weight <i>W</i> (kg)
SG1.5S 50B - 1520	50	φ 75	φ 78	B1	15	φ20	φ50	15	30	0.67
SG1.5S 52B - 1520	52	φ 78	φ 81	B1	15	φ20	φ50	15	30	0.72
SG1.5S 55B - 1520	55	φ 82.5	φ 85.5	B1	15	φ20	φ50	15	30	0.78
SG1.5S 56B - 1520	56	φ 84	φ 87	B1	15	φ20	φ50	15	30	0.80
SG1.5S 60B - 1520	60	φ 90	φ 93	B1	15	φ20	φ60	15	30	1.00
SG1.5S 64B - 1520	64	φ 96	φ 99	B1	15	φ20	φ60	15	30	1.10
SG1.5S 70B - 1520	70	φ105	φ108	B1	15	φ20	φ60	15	30	1.27
SG1.5S 72B - 1520	72	φ108	φ111	B1	15	φ20	φ60	15	30	1.33
SG1.5S 75B - 1520	75	φ112.5	φ115.5	B1	15	φ20	φ60	15	30	1.42
SG1.5S 80B - 1520	80	φ120	φ123	B1	15	φ20	φ60	15	30	1.58
SG1.5S 90B - 1525	90	φ135	φ138	B1	15	φ25	φ70	15	30	2.01
SG1.5S 100B - 1525	100	φ150	φ153	B1	15	φ25	φ70	15	30	2.40
SG1.5S 112B - 1525	112	φ168	φ171	B1	15	φ25	φ70	15	30	2.93
SG1.5S 120B - 1525	120	φ180	φ183	B1	15	φ25	φ70	15	30	3.31

Gear tooth surface completed with induction hardening, Hardness HRC49 to 55.

許容伝動力表 曲げ強さ (kW)

Allowable transfer capability table (kW) Bending Strength

歯数 <i>z</i>	歯幅 <i>b</i>	回転速度 (min ⁻¹) revolution/min						
		400	800	1,200	1,500	1,800	2,500	3,000
50	15	6.24	12.44	17.96	21.99	25.91	34.07	39.20
52	15	6.55	13.02	18.76	22.99	27.07	35.44	40.80
55	15	7.01	13.87	19.98	24.48	28.79	37.47	43.26
56	15	7.17	14.15	20.39	24.97	29.36	38.14	44.07
60	15	7.79	15.29	22.03	26.94	31.52	40.76	47.28
64	15	8.41	16.41	23.65	28.88	33.62	43.48	50.43
70	15	9.35	18.07	26.06	31.71	36.68	47.56	55.02
72	15	9.67	18.62	26.86	32.60	37.68	48.90	56.52
75	15	10.14	19.44	28.05	33.92	39.16	50.88	58.74
80	15	10.93	20.80	30.01	36.08	41.57	54.12	61.89
90	15	12.49	23.55	33.71	40.22	46.39	60.33	67.34
100	15	14.03	26.28	37.20	44.20	51.28	65.34	72.38
112	15	15.78	29.50	41.21	49.15	56.93	70.67	-
120	15	16.94	31.61	43.79	52.40	60.57	73.96	-

The above references are JGMA standard.

動力の換算式は P26 をご参照ください。Please refer to the conversion formulas of power on page P26.

歯面強さ (kW)

Allowable transfer capability table (kW) Surface Durability

回転速度 (min ⁻¹) revolution/min							
400	800	1,200	1,500	1,800	2,500	3,000	
3.00	6.14	9.04	11.21	13.34	17.90	20.82	
3.26	6.64	9.78	12.13	14.43	19.27	22.43	
3.66	7.44	10.94	13.57	16.14	21.42	25.00	
3.80	7.71	11.35	14.07	16.72	22.15	25.88	
4.39	8.86	13.04	16.15	19.11	25.19	29.54	
5.02	10.08	14.85	18.37	21.61	28.51	33.41	
6.05	12.05	17.77	21.91	25.62	33.87	39.60	
6.41	12.75	18.80	23.12	27.02	35.75	41.76	
6.98	13.82	20.40	25.00	29.18	38.65	45.08	
7.99	15.72	23.20	28.27	32.93	43.70	50.47	
10.21	19.93	29.21	35.32	41.18	54.56	61.49	
12.68	24.63	35.71	43.00	50.42	65.43	73.16	
15.93	30.91	44.24	53.46	62.57	79.05	-	
18.29	35.47	50.34	61.03	71.27	88.54	-	

歯研平歯車 GROUND SPUR GEARS

モジュール
MODULE

2

圧力角 20° (並歯)
20° PRESSURE ANGLE FULL DEPTH TOOTH

歯部高周波焼き入れ HRC49 ~ 55
JIS B 1702-1 (ISO) 5 級
System of accuracy: JIS B1702-1(ISO) class 5



御注文には必ず“フルネームで商品記号”を明記してください。
Please refer to the catalogue reference while ordering.

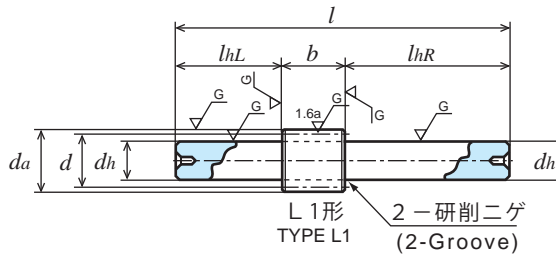

SCM435、440 クロムモリブデン鋼 (JIS G 4053) Material : Chromium Molybdenum Steel (ISO 34CrMo4, 42CrMo4)

単位 : mm
Dimensions : mm

商品記号 Catalogue Number	歯数 Number of Teeth z	基準円直径 Reference Diameter d	歯先円直径 Tip Diameter da	形 Type	歯幅 Face Width b	穴径 Bore Diameter da(H7)	ハブ外径 Hub Diameter dh	ハブ長さ Hub Projection lh	全長 Overall Length l	重量 Weight W(kg)
SG2S 14L - 2012	14	φ28	φ32	L1	20	-	φ12 (h7)	L25 R60	105	0.17
SG2S 14B - 2012	14	φ28	φ32	B1	20	φ12	φ22	20	40	0.12
SG2S 15L - 2012	15	φ30	φ34	L1	20	-	φ12 (h7)	L25 R60	105	0.19
SG2S 15B - 2012	15	φ30	φ34	B1	20	φ12	φ22	20	40	0.13
SG2S 16L - 2015	16	φ32	φ36	L1	20	-	φ15 (h7)	L25 R60	105	0.24
SG2S 16B - 2012	16	φ32	φ36	B1	20	φ12	φ25	20	40	0.17
SG2S 17B - 2012	17	φ34	φ38	B1	20	φ12	φ25	20	40	0.18
SG2S 18L - 2015	18	φ36	φ40	L1	20	-	φ15 (h7)	L25 R60	105	0.28
SG2S 18B - 2015	18	φ36	φ40	B1	20	φ15	φ30	20	40	0.21
SG2S 20B - 2015	20	φ40	φ44	B1	20	φ15	φ30	20	40	0.25
SG2S 21B - 2015	21	φ42	φ46	B1	20	φ15	φ30	20	40	0.27
SG2S 22B - 2015	22	φ44	φ48	B1	20	φ15	φ30	20	40	0.29
SG2S 23B - 2015	23	φ46	φ50	B1	20	φ15	φ30	20	40	0.31
SG2S 24B - 2015	24	φ48	φ52	B1	20	φ15	φ40	20	40	0.42

Gear tooth surface completed with induction hardening, Hardness HRC49 to 55.

許容伝達動力表 曲げ強さ (kW)

Allowable transfer capability table (kW) Bending Strength

歯数 z	歯幅 b	回転速度 (min ⁻¹) revolution/min						
		400	800	1,200	1,500	1,800	2,500	3,000
14	20	2.46	4.92	7.39	9.23	11.08	15.13	17.84
15	20	2.76	5.52	8.28	10.35	12.42	16.85	19.84
16	20	3.06	6.12	9.19	11.48	13.77	18.58	21.86
17	20	3.37	6.74	10.11	12.63	15.08	20.32	23.94
18	20	3.68	7.36	11.04	13.80	16.40	22.06	26.02
20	20	4.32	8.64	12.96	16.15	19.08	25.63	30.25
21	20	4.64	9.29	13.93	17.29	20.41	27.43	32.36
22	20	4.97	9.94	14.92	18.44	21.75	29.25	34.47
23	20	5.30	10.61	15.91	19.59	23.09	31.06	36.59
24	20	5.63	11.27	16.90	20.73	24.42	32.87	38.68

The above references are JGMA standard.

動力の換算式は P26 をご参照ください。Please refer to the conversion formulas of power on page P26.

歯面強さ (kW)

Allowable transfer capability table (kW) Surface Durability

回転速度 (min ⁻¹) revolution/min						
400	800	1,200	1,500	1,800	2,500	3,000
0.52	1.06	1.60	2.02	2.44	3.39	4.03
0.60	1.22	1.85	2.33	2.82	3.89	4.62
0.69	1.39	2.12	2.67	3.23	4.42	5.25
0.78	1.58	2.40	3.08	3.65	4.99	5.94
0.88	1.78	2.71	3.41	4.09	5.59	6.66
1.09	2.22	3.37	4.24	5.05	6.90	8.23
1.21	2.45	3.73	4.68	5.57	7.62	9.08
1.33	2.70	4.11	5.14	6.11	8.37	9.97
1.45	2.96	4.51	5.62	6.68	9.15	10.89
1.59	3.24	4.93	6.12	7.27	9.97	11.86

目次
CONTENTS

インフォメーション
INFORMATION

ギヤボックス
GEAR BOXES

ノーバッキングギヤ
ANTI BACKLASH SPUR GEARS

歯研平歯車
GROUND SPUR GEARS

平歯車
SPUR GEARS

内歯車
INTERNAL GEARS

歯研ラック
GROUND RACKS

ラック
RACKS

ハニカムギヤ
HEXAGONAL GEAR AND SCREW GEARS

ワーム
WORMS AND WORM WHEELS

かさ歯車
BEVEL GEARS

スプロケット
SPROCKETS

技術資料
REFERENCE DATA

歯研平歯車

GROUND SPUR GEARS

モジュール
MODULE

2

圧力角 20° (並歯)
20° PRESSURE ANGLE FULL DEPTH TOOTH

歯部高周波焼き入れ HRC49 ~ 55
JIS B 1702-1 (ISO) 5 級
System of accuracy: JIS B1702-1(ISO) class 5

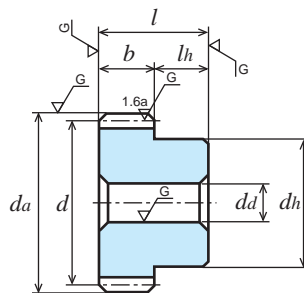

B1形
TYPE B1

SCM435、440 クロムモリブデン鋼 (JIS G 4053)

Material : Chromium Molybdenum Steel (ISO 34CrMo4, 42CrMo4)

単位 : mm
Dimensions : mm

商品記号 Catalogue Number	歯数 Number of Teeth <i>z</i>	基準円直径 Reference Diameter <i>d</i>	歯先円直径 Tip Diameter <i>da</i>	形 Type	歯幅 Face Width <i>b</i>	穴径 Bore Diameter <i>da</i> (H7)	ハブ外径 Hub Diameter <i>dh</i>	ハブ長さ Hub Projection <i>lh</i>	全長 Overall Length <i>l</i>	重量 Weight <i>W</i> (kg)
SG2S 25B - 2015	25	φ50	φ54	B1	20	φ15	φ40	20	40	0.45
SG2S 26B - 2015	26	φ52	φ56	B1	20	φ15	φ40	20	40	0.47
SG2S 27B - 2015	27	φ54	φ58	B1	20	φ15	φ40	20	40	0.50
SG2S 28B - 2015	28	φ56	φ60	B1	20	φ15	φ40	20	40	0.53
SG2S 30B - 2015	30	φ60	φ64	B1	20	φ15	φ40	20	40	0.58
SG2S 32B - 2020	32	φ64	φ68	B1	20	φ20	φ50	20	40	0.71
SG2S 34B - 2020	34	φ68	φ72	B1	20	φ20	φ50	20	40	0.77
SG2S 35B - 2020	35	φ70	φ74	B1	20	φ20	φ50	20	40	0.81
SG2S 36B - 2020	36	φ72	φ76	B1	20	φ20	φ50	20	40	0.84
SG2S 38B - 2020	38	φ76	φ80	B1	20	φ20	φ60	20	40	1.05
SG2S 40B - 2020	40	φ80	φ84	B1	20	φ20	φ60	20	40	1.13
SG2S 42B - 2020	42	φ84	φ88	B1	20	φ20	φ60	20	40	1.21
SG2S 44B - 2020	44	φ88	φ92	B1	20	φ20	φ60	20	40	1.29
SG2S 45B - 2020	45	φ90	φ94	B1	20	φ20	φ60	20	40	1.34

Gear tooth surface completed with induction hardening, Hardness HRC49 to 55.

許容伝動力表 曲げ強さ (kW)

Allowable transfer capability table (kW) Bending Strength

歯数 <i>z</i>	歯幅 <i>b</i>	回転速度 (min ⁻¹) revolution/min						
		400	800	1,200	1,500	1,800	2,500	3,000
25	20	5.97	11.94	17.84	21.88	25.76	34.68	40.79
26	20	6.31	12.61	18.79	23.03	27.09	36.49	42.84
27	20	6.65	13.29	19.75	24.17	28.44	38.30	44.83
28	20	6.99	13.98	20.70	25.32	29.82	40.11	46.80
30	20	7.67	15.35	22.59	27.59	32.55	43.69	50.68
32	20	8.37	16.76	24.48	29.87	35.28	47.14	54.51
34	20	9.07	18.14	26.36	32.21	38.01	50.49	58.27
35	20	9.42	18.84	27.30	33.38	39.37	52.14	60.13
36	20	9.77	19.54	28.24	34.54	40.73	53.78	61.97
38	20	10.48	20.87	30.11	36.87	43.43	57.03	65.60
40	20	11.20	22.20	31.97	39.19	46.12	60.23	69.43
42	20	11.91	23.52	33.89	41.49	48.80	63.37	73.24
44	20	12.62	24.82	35.77	43.76	51.30	66.42	76.96
45	20	12.99	25.48	36.72	44.90	52.55	67.94	78.82

The above references are JGMA standard.

動力の換算式は P26 をご参照ください。Please refer to the conversion formulas of power on page P26.

歯面強さ (kW)

Allowable transfer capability table (kW) Surface Durability

回転速度 (min ⁻¹) revolution/min							
400	800	1,200	1,500	1,800	2,500	3,000	
1.73	3.52	5.36	6.64	7.89	10.82	12.86	
1.87	3.82	5.80	7.18	8.53	11.70	13.88	
2.03	4.14	6.25	7.74	9.19	12.62	14.92	
2.18	4.66	6.73	8.32	9.90	13.57	16.00	
2.52	5.15	7.72	9.55	11.37	15.56	18.25	
2.88	5.90	8.79	10.85	12.95	17.64	20.62	
3.27	6.69	9.92	12.27	14.63	19.81	23.11	
3.47	7.11	10.51	13.00	15.50	20.93	24.40	
3.68	7.54	11.12	13.76	16.40	22.08	25.72	
4.12	8.41	12.38	15.35	18.27	24.47	28.45	
4.58	9.32	13.71	17.01	20.24	26.95	31.41	
5.07	10.28	15.13	18.76	22.30	29.54	34.50	
5.58	11.29	16.62	20.59	24.40	32.22	37.73	
5.85	11.81	17.38	21.53	25.47	33.59	39.39	

齒研平齒車

GROUND SPUR GEARS

モジュール
MODULE

2

圧力角 20° (並歯)
20° PRESSURE ANGLE FULL DEPTH TOOTH

歯部高周波焼き入れ HRC49 ~ 55
JIS B 1702-1 (ISO) 5 級
System of accuracy: JIS B1702-1(ISO) class 5



御注文には必ず“フルネームで商品記号”を明記してください。
Please refer to the catalogue reference while ordering.

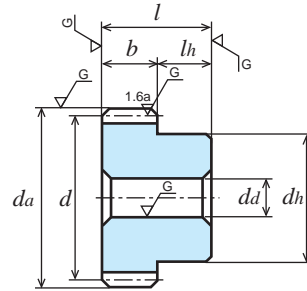

B1形
TYPE B1

SCM435、440 クロムモリブデン鋼 (JIS G 4053)

Material : Chromium Molybdenum Steel (ISO 34CrMo4, 42CrMo4)

単位 : mm
Dimensions : mm

商品記号 Catalogue Number	歯数 Number of Teeth <i>z</i>	基準円直径 Reference Diameter <i>d</i>	歯先円直径 Tip Diameter <i>da</i>	形 Type	歯幅 Face Width <i>b</i>	穴径 Bore Diameter <i>da</i> (H7)	ハブ外径 Hub Diameter <i>dh</i>	ハブ長さ Hub Projection <i>lh</i>	全長 Overall Length <i>l</i>	重量 Weight <i>W</i> (kg)
SG2S 48B - 2020	48	φ 96	φ100	B1	20	20	φ60	20	40	1.47
SG2S 50B - 2020	50	φ100	φ104	B1	20	20	φ60	20	40	1.57
SG2S 52B - 2020	52	φ104	φ108	B1	20	20	φ60	20	40	1.67
SG2S 54B - 2020	54	φ108	φ112	B1	20	20	φ60	20	40	1.78
SG2S 55B - 2020	55	φ110	φ114	B1	20	20	φ60	20	40	1.83
SG2S 56B - 2020	56	φ112	φ116	B1	20	20	φ60	20	40	1.88
SG2S 60B - 2025	60	φ120	φ124	B1	20	25	φ70	20	40	2.21
SG2S 64B - 2025	64	φ128	φ132	B1	20	25	φ70	20	40	2.45
SG2S 70B - 2025	70	φ140	φ144	B1	20	25	φ70	20	40	2.85
SG2S 72B - 2025	72	φ144	φ148	B1	20	25	φ80	20	40	3.17
SG2S 75B - 2025	75	φ150	φ154	B1	20	25	φ80	20	40	3.39
SG2S 80B - 2025	80	φ160	φ164	B1	20	25	φ80	20	40	3.77
SG2S 90B - 2025	90	φ180	φ184	B1	20	25	φ80	20	40	4.60
SG2S 100B - 2030	100	φ200	φ204	B1	20	30	φ80	20	40	5.46

Gear tooth surface completed with induction hardening, Hardness HRC49 to 55.

許容伝動力表 曲げ強さ (kW)

Allowable transfer capability table (kW) Bending Strength

歯数 <i>z</i>	歯幅 <i>b</i>	回転速度 (min ⁻¹) revolution/min						
		400	800	1,200	1,500	1,800	2,500	3,000
48	20	14.07	27.44	39.56	48.31	56.23	72.72	84.34
50	20	14.80	28.74	41.44	50.56	58.64	75.93	87.96
52	20	15.53	30.04	43.31	52.74	61.03	79.10	91.54
54	20	16.26	31.33	45.17	54.83	63.38	82.24	95.07
55	20	16.63	31.97	46.10	55.87	64.54	83.80	96.81
56	20	16.99	32.61	47.03	56.90	65.70	85.35	98.55
60	20	18.46	35.16	50.71	60.97	70.25	91.46	104.57
64	20	19.94	37.77	54.34	64.96	74.72	97.43	109.96
70	20	22.17	41.66	59.39	70.76	81.78	105.82	117.59
72	20	22.90	42.94	61.04	72.65	84.09	108.14	120.01
75	20	23.95	44.86	63.49	75.44	87.52	111.53	123.54
80	20	25.68	48.04	67.49	80.31	93.15	116.96	-
90	20	29.06	54.23	75.12	89.89	103.90	126.88	-
100	20	32.41	60.17	82.79	99.19	113.41	-	-

The above references are JGMA standard.

動力の換算式は P26 をご参照ください。Please refer to the conversion formulas of power on page P26.

歯面強さ (kW)

Allowable transfer capability table (kW) Surface Durability

回転速度 (min ⁻¹) revolution/min						
400	800	1,200	1,500	1,800	2,500	3,000
6.69	13.44	19.80	24.49	28.82	38.01	44.55
7.28	14.58	21.49	26.56	31.15	41.12	48.14
7.90	15.76	23.24	28.68	33.55	44.34	51.85
8.55	16.99	25.07	30.83	36.03	47.67	55.67
8.88	17.63	26.01	31.93	37.30	49.37	57.63
9.22	18.27	26.96	33.05	38.58	51.10	59.61
10.65	20.95	30.93	37.69	43.91	58.26	67.29
12.18	23.87	35.16	42.59	49.53	65.82	75.02
14.69	28.59	41.75	50.41	58.89	77.64	87.09
15.58	30.26	44.06	53.14	62.17	81.44	91.23
16.91	32.84	47.61	57.34	67.23	87.25	97.54
19.26	37.38	53.80	64.88	76.04	97.20	-
24.39	47.29	67.12	81.37	95.03	118.05	-
30.11	58.13	81.94	99.45	114.85	-	-

目次
CONTENTS

インフォメーション
INFORMATION

ギヤボックス
GEAR BOXES

ノーバックラッシュギヤ
ANTI BACKLASH SPUR GEARS

歯研平歯車
GROUND SPUR GEARS

平歯車
SPUR GEARS

内歯車
INTERNAL GEARS

歯研ラック
GROUND RACKS

ラック
RACKS

ハニカム・スクリューギヤ
HELICAL GEARS AND SCREW GEARS

ウォーム・ウォームホイール
WORMS AND WORM WHEELS

かさ歯車
BEVEL GEARS

スプロケット
SPROCKETS

技術仕様
REFERENCE DATA

歯研平歯車 GROUND SPUR GEARS

モジュール **2.5** 圧力角 20° (並歯)
MODULE 2.5 20° PRESSURE ANGLE FULL DEPTH TOOTH

歯部高周波焼き入れ HRC49 ~ 55
JIS B 1702-1 (ISO) 5 級
System of accuracy: JIS B1702-1(ISO) class 5

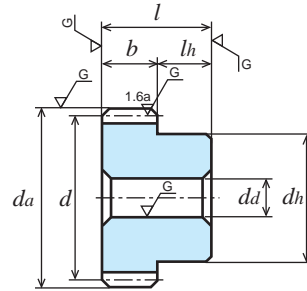

B1形
TYPE B1

SCM435、440 クロムモリブデン鋼 (JIS G 4053) Material : Chromium Molybdenum Steel (ISO 34CrMo4, 42CrMo4)

単位 : mm
Dimensions : mm

商品記号 Catalogue Number	歯数 Number of Teeth <i>z</i>	基準円直径 Reference Diameter <i>d</i>	歯先円直径 Tip Diameter <i>da</i>	形 Type	歯幅 Face Width <i>b</i>	穴径 Bore Diameter <i>da</i> (H7)	ハブ外径 Hub Diameter <i>dh</i>	ハブ長さ Hub Projection <i>lh</i>	全長 Overall Length <i>l</i>	重量 Weight <i>W</i> (kg)
SG2.5S 14B - 2515	14	φ35	φ40	B1	25	φ15	φ28	20	45	0.2
SG2.5S 15B - 2515	15	φ37.5	φ42.5	B1	25	φ15	φ28	20	45	0.3
SG2.5S 16B - 2515	16	φ40	φ45	B1	25	φ15	φ28	20	45	0.3
SG2.5S 18B - 2520	18	φ45	φ50	B1	25	φ20	φ38	20	45	0.4
SG2.5S 20B - 2520	20	φ50	φ55	B1	25	φ20	φ38	20	45	0.5
SG2.5S 24B - 2520	24	φ60	φ65	B1	25	φ20	φ50	20	45	0.8
SG2.5S 25B - 2520	25	φ62.5	φ67.5	B1	25	φ20	φ50	20	45	0.8
SG2.5S 28B - 2520	28	φ70	φ75	B1	25	φ20	φ60	20	45	1.1
SG2.5S 30B - 2520	30	φ75	φ80	B1	25	φ20	φ60	20	45	1.2
SG2.5S 32B - 2520	32	φ80	φ85	B1	25	φ20	φ60	20	45	1.3
SG2.5S 35B - 2525	35	φ87.5	φ92.5	B1	25	φ25	φ70	20	45	1.6
SG2.5S 36B - 2525	36	φ90	φ95	B1	25	φ25	φ70	20	45	1.7

Gear tooth surface completed with induction hardening, Hardness HRC49 to 55.

許容伝達動力表 曲げ強さ (kW)

Allowable transfer capability table (kW) Bending Strength

歯数 <i>z</i>	歯幅 <i>b</i>	回転速度 (min ⁻¹) revolution/min						
		400	800	1,200	1,500	1,800	2,500	3,000
14	25	4.81	9.62	14.42	18.03	21.48	28.91	34.08
15	25	5.39	10.78	16.17	20.21	23.93	32.14	37.95
16	25	5.98	11.96	17.94	22.35	26.40	35.46	41.86
18	25	7.19	14.38	21.57	26.60	31.38	42.19	49.72
20	25	8.44	16.88	25.23	30.94	36.42	49.04	57.68
24	25	11.00	22.01	32.39	39.57	46.67	62.66	72.67
25	25	11.66	23.32	34.18	41.73	49.27	65.97	76.34
28	25	13.65	27.30	39.56	48.36	57.05	75.55	87.13
30	25	14.99	29.87	43.11	52.78	62.19	81.77	94.10
32	25	16.34	32.40	46.67	57.20	67.33	87.92	101.35
35	25	18.40	36.19	52.15	63.81	74.84	96.92	112.26
36	25	19.09	37.45	53.97	66.00	77.24	99.87	115.86

歯面強さ (kW)

Allowable transfer capability table (kW) Surface Durability

回転速度 (min ⁻¹) revolution/min						
400	800	1,200	1,500	1,800	2,500	3,000
1.03	2.10	3.19	4.02	4.83	6.61	7.87
1.19	2.42	3.68	4.65	5.55	7.58	9.04
1.36	2.77	4.21	5.30	6.32	8.63	10.29
1.74	3.54	5.39	6.72	7.99	10.94	13.03
2.16	4.41	6.69	8.30	9.86	13.52	16.07
3.15	6.44	9.66	11.93	14.22	19.45	22.81
3.43	7.02	10.48	12.94	15.43	21.07	24.64
4.34	8.89	13.14	16.26	19.37	26.16	30.51
5.00	10.23	15.07	18.68	22.24	29.83	34.70
5.72	11.65	17.13	21.26	25.30	33.69	39.26
6.89	13.95	20.53	25.44	30.17	39.85	46.65
7.31	14.76	21.73	26.92	31.84	41.99	49.24

The above references are JGMA standard.

動力の換算式は P26 をご参照ください。Please refer to the conversion formulas of power on page P26.

歯研平歯車

GROUND SPUR GEARS

モジュール **2.5** 圧力角 20° (並歯)
 MODULE 2.5 20° PRESSURE ANGLE FULL DEPTH TOOTH

歯部高周波焼き入れ HRC49 ~ 55
 JIS B 1702-1 (ISO) 5 級
 System of accuracy: JIS B1702-1(ISO) class 5



御注文には必ず“フルネームで商品記号”を明記してください。
 Please refer to the catalogue reference while ordering.

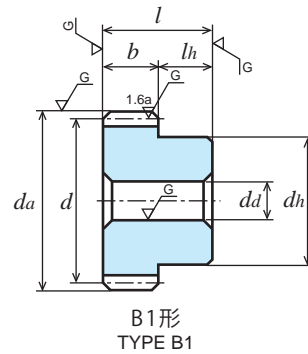

SCM435、440 クロムモリブデン鋼 (JIS G 4053)

Material : Chromium Molybdenum Steel (ISO 34CrMo4, 42CrMo4)

単位 : mm
 Dimensions : mm

商品記号 Catalogue Number	歯数 Number of Teeth <i>z</i>	基準円直径 Reference Diameter <i>d</i>	歯先円直径 Tip Diameter <i>da</i>	形 Type	歯幅 Face Width <i>b</i>	穴径 Bore Diameter <i>da</i> (H7)	ハブ外径 Hub Diameter <i>dh</i>	ハブ長さ Hub Projection <i>lh</i>	全長 Overall Length <i>l</i>	重量 Weight <i>W</i> (kg)
SG2.5S 40B - 2525	40	φ100	φ105	B1	25	φ25	φ70	20	45	2.0
SG2.5S 45B - 2525	45	φ112.5	φ117.5	B1	25	φ25	φ70	20	45	2.4
SG2.5S 48B - 2525	48	φ120	φ125	B1	25	φ25	φ70	20	45	2.5
SG2.5S 50B - 2530	50	φ125	φ130	B1	25	φ30	φ80	20	45	2.8
SG2.5S 55B - 2530	55	φ137.5	φ142.5	B1	25	φ30	φ80	20	45	3.4
SG2.5S 56B - 2530	56	φ140	φ145	B1	25	φ30	φ80	20	45	3.5
SG2.5S 60B - 2530	60	φ150	φ155	B1	25	φ30	φ80	20	45	4.0
SG2.5S 64B - 2530	64	φ160	φ165	B1	25	φ30	φ80	20	45	4.5
SG2.5S 70B - 2530	70	φ175	φ180	B1	25	φ30	φ90	20	45	5.4
SG2.5S 72B - 2530	72	φ180	φ185	B1	25	φ30	φ90	20	45	5.7
SG2.5S 75B - 2530	75	φ187.5	φ192.5	B1	25	φ30	φ90	20	45	6.1
SG2.5S 80B - 2530	80	φ200	φ205	B1	25	φ30	φ90	20	45	6.9

Gear tooth surface completed with induction hardening, Hardness HRC49 to 55.

許容伝達動力表 曲げ強さ (kW)

Allowable transfer capability table (kW) Bending Strength

歯数 <i>z</i>	歯幅 <i>b</i>	回転速度 (min ⁻¹) revolution/min						
		400	800	1,200	1,500	1,800	2,500	3,000
40	25	21.87	42.47	61.23	74.71	86.65	112.19	129.97
45	25	25.36	48.64	70.16	84.85	97.96	127.28	146.94
48	25	27.48	52.33	75.48	90.76	104.57	136.13	155.65
50	25	28.90	54.85	79.00	94.63	108.89	141.94	160.97
55	25	32.47	61.12	87.29	104.08	120.17	156.12	173.61
56	25	33.19	62.36	88.91	105.93	122.43	158.43	176.03
60	25	35.94	67.32	95.27	113.22	131.34	167.37	185.40
64	25	38.61	72.24	101.49	120.77	140.07	175.88	-
70	25	42.59	79.53	110.56	132.11	152.83	187.90	-
72	25	43.91	81.94	113.52	135.82	157.00	191.72	-
75	25	45.87	85.53	117.88	141.33	163.16	197.29	-
80	25	49.13	91.20	125.49	150.35	171.91	-	-

The above references are JGMA standard.

動力の換算式は P26 をご参照ください。Please refer to the conversion formulas of power on page P26.

歯面強さ (kW)

Allowable transfer capability table (kW) Surface Durability

	回転速度 (min ⁻¹) revolution/min					
	400	800	1,200	1,500	1,800	2,500
9.10	18.22	26.86	33.20	38.93	51.40	60.18
11.63	23.04	34.00	41.67	48.64	64.42	75.14
13.31	26.19	38.67	47.12	54.88	72.83	84.11
14.49	28.44	41.94	50.91	59.22	78.68	90.11
17.69	34.47	50.42	60.92	71.11	94.11	105.66
18.36	35.74	52.18	63.02	73.62	97.04	108.86
21.14	41.06	59.51	71.67	84.04	109.06	121.93
24.07	46.72	67.25	81.09	95.05	121.50	-
28.82	55.88	79.59	96.37	112.64	140.91	-
30.49	59.11	83.90	101.71	118.78	147.57	-
33.09	64.11	90.53	109.96	128.25	157.71	-
37.64	72.66	102.43	124.31	143.57	-	-

目次
CONTENTS

インフォメーション
INFORMATION

ギヤボックス
GEAR BOXES

ノーバッキングギヤ
ANTI BACKLASH SPUR GEARS

歯研平歯車
GROUND SPUR GEARS

平歯車
SPUR GEARS

内歯車
INTERNAL GEARS

歯研ラック
GROUND RACKS

ラック
RACKS

へリカル・スクリューギヤ
HELICAL GEARS AND SCREW GEARS

ウォーム・ウォームホイール
WORMS AND WORM WHEELS

かさ歯車
BEVEL GEARS

スプロケット
SPROCKETS

技術資料
REFERENCE DATA

歯研平歯車

GROUND SPUR GEARS

モジュール
MODULE

3

圧力角 20° (並歯)
20° PRESSURE ANGLE FULL DEPTH TOOTH

歯部高周波焼き入れ HRC49 ~ 55
JIS B 1702-1 (ISO) 5 級
System of accuracy: JIS B1702-1(ISO) class 5

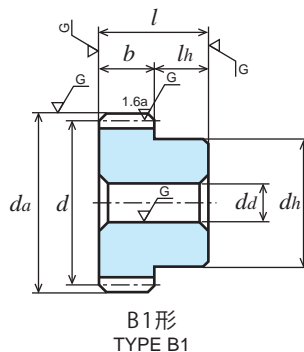

SCM435、440 クロムモリブデン鋼 (JIS G 4053)

Material : Chromium Molybdenum Steel (ISO 34CrMo4, 42CrMo4)

単位 : mm
Dimensions : mm

商品記号 Catalogue Number	歯数 Number of Teeth <i>z</i>	基準円直径 Reference Diameter <i>d</i>	歯先円直径 Tip Diameter <i>da</i>	形 Type	歯幅 Face Width <i>b</i>	穴径 Bore Diameter <i>da</i> (H7)	ハブ外径 Hub Diameter <i>dh</i>	ハブ長さ Hub Projection <i>lh</i>	全長 Overall Length <i>l</i>	重量 Weight <i>W</i> (kg)
SG3S 14B - 3015	14	φ 42	φ 48	B1	30	φ15	φ34	20	50	0.4
SG3S 15B - 3015	15	φ 45	φ 51	B1	30	φ15	φ36	20	50	0.5
SG3S 16B - 3015	16	φ 48	φ 54	B1	30	φ15	φ36	20	50	0.5
SG3S 18B - 3020	18	φ 54	φ 60	B1	30	φ20	φ45	20	50	0.7
SG3S 20B - 3020	20	φ 60	φ 66	B1	30	φ20	φ45	20	50	0.8
SG3S 24B - 3020	24	φ 72	φ 78	B1	30	φ20	φ50	20	50	1.1
SG3S 25B - 3020	25	φ 75	φ 81	B1	30	φ20	φ50	20	50	1.2
SG3S 28B - 3025	28	φ 84	φ 90	B1	30	φ25	φ60	20	50	1.6
SG3S 30B - 3025	30	φ 90	φ 96	B1	30	φ25	φ60	20	50	1.7
SG3S 32B - 3025	32	φ 96	φ102	B1	30	φ25	φ60	20	50	1.9
SG3S 35B - 3030	35	φ105	φ111	B1	30	φ30	φ70	20	50	2.3
SG3S 36B - 3030	36	φ108	φ114	B1	30	φ30	φ70	20	50	2.5

Gear tooth surface completed with induction hardening, Hardness HRC49 to 55.

許容伝達動力表 曲げ強さ (kW)

Allowable transfer capability table (kW) Bending Strength

歯数 <i>z</i>	歯幅 <i>b</i>	回転速度 (min ⁻¹) revolution/min						
		400	800	1,200	1,500	1,800	2,500	3,000
14	30	8.31	16.62	24.93	30.93	36.51	49.07	57.88
15	30	9.31	18.62	27.93	34.46	40.64	54.65	64.40
16	30	10.33	20.67	30.99	38.02	44.79	60.28	70.95
18	30	12.42	24.84	36.90	45.18	53.16	71.59	83.78
20	30	14.59	29.17	42.93	52.45	61.87	83.06	96.33
24	30	19.01	38.01	54.95	67.21	79.24	104.65	120.57
25	30	20.15	40.15	57.96	70.95	83.59	109.93	126.49
28	30	23.59	46.57	67.09	82.15	96.61	125.47	145.00
30	30	25.90	50.82	73.23	89.55	104.80	135.50	157.19
32	30	28.24	55.08	79.39	96.95	112.84	145.94	169.26
35	30	31.79	61.43	88.58	107.77	124.68	161.66	187.02
36	30	32.98	63.54	91.64	111.22	128.56	166.83	192.84

The above references are JGMA standard.

動力の換算式は P26 をご参照ください。Please refer to the conversion formulas of power on page P26.

歯面強さ (kW)

Allowable transfer capability table (kW) Surface Durability

回転速度 (min ⁻¹) revolution/min						
400	800	1,200	1,500	1,800	2,500	3,000
1.81	3.68	5.60	7.02	8.36	11.43	13.62
2.08	4.25	6.47	8.06	9.59	13.13	15.64
2.38	4.86	7.40	9.17	10.91	14.95	17.78
3.04	6.21	9.38	11.61	13.79	18.92	22.39
3.78	7.73	11.59	14.32	17.06	23.34	27.37
5.52	11.31	16.68	20.65	24.60	33.13	38.59
6.01	12.28	18.09	22.41	26.69	35.79	41.64
7.60	15.42	22.69	28.14	33.45	44.30	51.76
8.77	17.71	26.08	32.30	38.21	50.39	59.08
10.03	20.15	29.69	36.74	43.23	57.01	66.83
12.09	24.10	35.54	43.81	51.24	67.75	79.19
12.82	25.49	37.60	46.25	54.04	71.51	83.51

歯研平歯車

GROUND SPUR GEARS

モジュール
MODULE

3

圧力角 20° (並歯)
20° PRESSURE ANGLE FULL DEPTH TOOTH

歯部高周波焼き入れ HRC49 ~ 55
JIS B 1702-1 (ISO) 5 級
System of accuracy: JIS B1702-1(ISO) class 5



御注文には必ず“フルネームで商品記号”を明記してください。
Please refer to the catalogue reference while ordering.

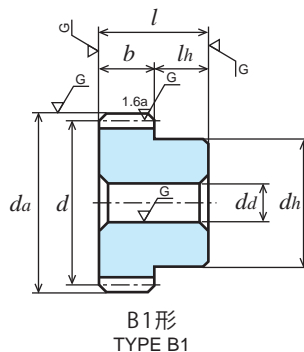

SCM435、440 クロムモリブデン鋼 (JIS G 4053)

Material : Chromium Molybdenum Steel (ISO 34CrMo4, 42CrMo4)

単位 : mm
Dimensions : mm

商品記号 Catalogue Number	歯数 Number of Teeth <i>z</i>	基準円直径 Reference Diameter <i>d</i>	歯先円直径 Tip Diameter <i>da</i>	形 Type	歯幅 Face Width <i>b</i>	穴径 Bore Diameter <i>da</i> (H7)	ハブ外径 Hub Diameter <i>dh</i>	ハブ長さ Hub Projection <i>lh</i>	全長 Overall Length <i>l</i>	重量 Weight <i>W</i> (kg)
SG3S 40B - 3030	40	φ120	φ126	B1	30	φ30	φ 70	20	50	3.0
SG3S 45B - 3030	45	φ135	φ141	B1	30	φ30	φ 80	20	50	3.9
SG3S 48B - 3030	48	φ144	φ150	B1	30	φ30	φ 80	20	50	4.3
SG3S 50B - 3030	50	φ150	φ156	B1	30	φ30	φ 80	20	50	4.6
SG3S 55B - 3035	55	φ165	φ171	B1	30	φ35	φ 90	20	50	5.6
SG3S 56B - 3035	56	φ168	φ174	B1	30	φ35	φ 90	20	50	5.8
SG3S 60B - 3035	60	φ180	φ186	B1	30	φ35	φ 90	20	50	6.6
SG3S 64B - 3040	64	φ192	φ198	B1	30	φ40	φ 90	20	50	7.3
SG3S 70B - 3040	70	φ210	φ216	B1	30	φ40	φ100	20	50	8.8
SG3S 72B - 3040	72	φ216	φ222	B1	30	φ40	φ100	20	50	9.3
SG3S 75B - 3040	75	φ225	φ231	B1	30	φ40	φ100	20	50	10.0
SG3S 80B - 3040	80	φ240	φ246	B1	30	φ40	φ100	20	50	11.3

Gear tooth surface completed with induction hardening, Hardness HRC49 to 55.

許容伝達動力表 曲げ強さ (kW)

Allowable transfer capability table (kW) Bending Strength

歯数 <i>z</i>	歯幅 <i>b</i>	回転速度 (min ⁻¹) revolution/min						
		400	800	1,200	1,500	1,800	2,500	3,000
40	30	37.79	71.94	103.77	124.77	143.76	187.16	214.00
45	30	43.83	82.62	118.23	141.06	162.71	211.59	236.20
48	30	47.47	89.00	126.51	150.58	174.29	224.14	248.74
50	30	49.77	93.24	131.94	156.80	181.90	231.80	256.76
55	30	55.48	103.74	145.22	173.05	200.54	250.00	-
56	30	56.62	105.82	147.83	176.30	204.19	253.49	-
60	30	61.14	114.10	158.07	189.13	218.62	266.97	-
64	30	65.63	122.26	168.12	201.71	232.50	-	-
70	30	72.29	133.62	184.00	220.08	249.18	-	-
72	30	74.50	137.34	189.20	226.08	254.51	-	-
75	30	77.78	142.85	196.93	234.96	262.28	-	-
80	30	83.22	151.85	209.58	247.54	274.71	-	-

歯面強さ (kW)

Allowable transfer capability table (kW) Surface Durability

回転速度 (min ⁻¹) revolution/min						
400	800	1,200	1,500	1,800	2,500	3,000
15.97	31.43	46.40	56.54	65.86	87.40	100.93
20.43	39.86	58.41	70.63	82.36	109.12	122.99
23.37	45.39	66.08	79.71	93.26	122.16	136.84
25.37	49.27	71.42	86.01	100.85	130.87	146.32
30.73	59.63	85.52	103.27	120.93	153.45	-
31.86	61.82	88.47	106.92	125.14	158.10	-
36.59	70.93	100.68	122.05	142.54	177.08	-
41.63	80.62	113.58	138.05	160.74	-	-
49.78	95.73	135.04	163.59	187.06	-	-
52.66	101.01	142.56	172.51	196.11	-	-
57.11	109.17	154.16	186.25	209.93	-	-
64.93	123.36	174.37	208.50	233.57	-	-

The above references are JGMA standard.

動力の換算式は P26 をご参照ください。Please refer to the conversion formulas of power on page P26.

目次 CONTENTS

インフォメーション INFORMATION

ギヤボックス GEAR BOXES

ノーバッキングギヤ ANTI BACKLASH SPUR GEARS

歯研平歯車 GROUND SPUR GEARS

平歯車 SPUR GEARS

内歯車 INTERNAL GEARS

歯研ラック GROUND RACKS

ラック RACKS

へリカル・スクリューギヤ HELICAL GEARS AND SCREW GEARS

ウォーム・ウォームホイール WORMS AND WORM WHEELS

かさ歯車 BEVEL GEARS

スプロケット SPROCKETS

技術資料 REFERENCE DATA